

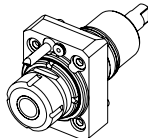

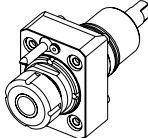

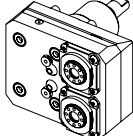





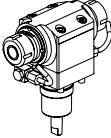
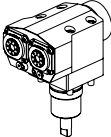
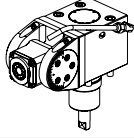

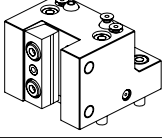
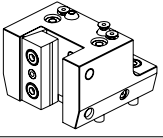
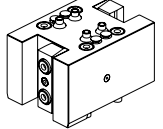
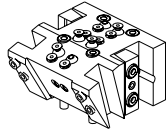
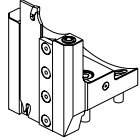
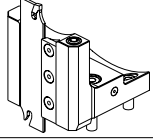
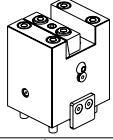
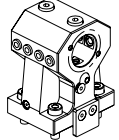
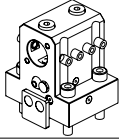
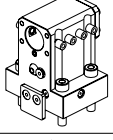
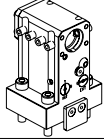
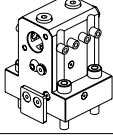
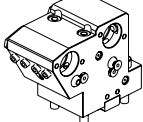
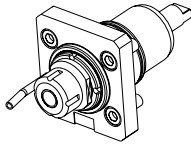
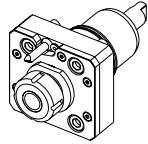
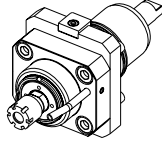
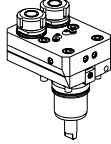
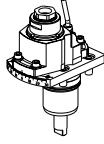
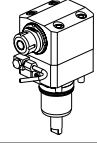
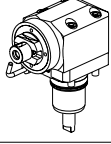
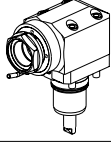

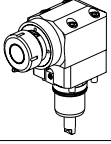

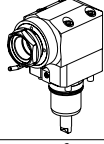
		PAGINA Page Seite
MODULO MOTORIZZATO RADIALE Radial driven tool Radial angetriebenes Werkzeug		NKM010.1.00
MODULO MOTORIZZATO RADIALE Radial driven tool Radial angetriebenes Werkzeug		NKM020.1.00
MODULO MOTORIZZATO RADIALE 2 USCITE IN Y Radial single side twin head driven tool in Y Radial angetriebenes Werkzeug 2 Ausgaenge in Y		NKM090.1.00
MODULO MOTORIZZATO ASSIALE Axial driven tool Axial angetriebenes Werkzeug		NKM150.1.10
MODULO MOTORIZZATO ASSIALE MOLTIPLICATO I = 1:2 Axial geared-up I=1:2 driven tool Axial angetriebenes Werkzeug uebersetzt I=1:2		NKM200.1.10
MODULO MOTORIZZATO ASSIALE BISPORGENTE H=60mm Axial opposite face twin driven tool H=60mm Axial angetriebenes Werkzeug halb vorspringend H=60mm		NKM240.1.10
MODULO MOTORIZZATO ASSIALE 2 USCITE IN Y Axial single side twin head driven tool in Y Axial angetriebenes Werkzeug 2 Ausgaenge in Y		NKM260.1.20
MODULO MOTORIZZATO ORIENTABILE ±90° ±90° adjustable angle driven tool Angetriebenes Werkzeug schwenkbar ±90°		NKM337.1.00 
PORTAUTENSILE RADIALE SINGOLO Radial single static tool Radial Single-Werkzeughalter		NKM420.1.00
PORTAUTENSILE RADIALE SINGOLO Radial single static tool Radial Single-Werkzeughalter		NKM423.1.00
PORTAUTENSILE RADIALE DOPPIO Radial double static tool Radial Doppel-Werkzeughalter		NKM450.1.00

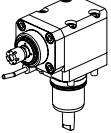
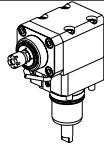
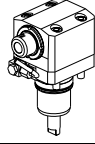
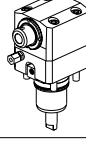
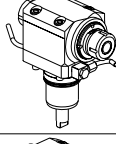
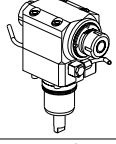
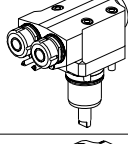
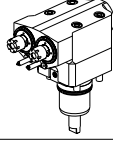
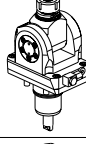
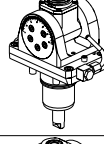

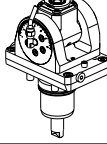
		PAGINA Page Seite
PORTAUTENSILE RADIALE MULTIPLO Radial multiple static tool Radial Mehrfach-Halter		NKM470.1.00
PORTAUTENSILE RADIALE PER LAMA Radial blade holder Radial Abstechhalter		NKM513.1.00
PORTAUTENSILE RADIALE PER LAMA Radial blade holder Radial Abstechhalter		NKM513.1.10
PORTAUTENSILE ASSIALE SINGOLO Axial single static tool Axial Single-Werkzeughalter		NKM550.1.00
PORTAUTENSILE ASSIALE PER BARENO Ø32mm H=75mm Axial single boring bar holder Ø32mm H=75mm Axial Bohrhalter Ø32mm H=75mm		NKM650.1.10
PORTAUTENSILE ASSIALE PER BARENO Ø25mm H=60mm Axial single boring bar holder Ø25mm H=60mm Axial Bohrhalter Ø25mm H=60mm		NKM670.1.10
PORTAUTENSILE ASSIALE PER BARENO Ø25mm H=75mm Axial single boring bar holder Ø25mm H=75mm Axial Bohrhalter Ø25mm H=75mm		NKM670.1.20
PORTAUTENSILE ASSIALE PER BARENO Ø25mm / Ø1" H=92,5mm Axial single boring bar holder Ø25mm / Ø1" H=92.5mm Axial Bohrhalter Ø25mm / Ø1" H=92.5mm		NKM685.1.10
PORTAUTENSILE ASSIALE PER BARENO Ø20mm H=70mm Axial single boring bar holder Ø20mm H=70mm Axial Bohrhalter Ø20mm H=70mm		NKM690.1.10
PORTAUTENSILE ASSIALE PER BARENO 2 POSIZIONI Ø25mm Axial double boring bar holder Ø25mm Axial Bohrhalter 2 Positionen Ø25mm		NKM864.1.50

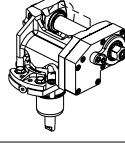
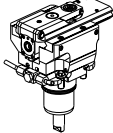
		PAGINA Page Seite
MODULO MOTORIZZATO RADIALE Radial driven tool Radial angetriebenes Werkzeug		NKM010.2.00
MODULO MOTORIZZATO RADIALE Radial driven tool Radial angetriebenes Werkzeug		NKM020.2.00
MODULO MOTORIZZATO RADIALE MOLTIPLICATO I=1.3 Radial geared-up I=1:3 driven tool Radial angetriebenes Werkzeug uebersetzt I=1:3		NKM055.2.00
MODULO MOTORIZZATO RADIALE 2 USCITE IN Y Radial single side twin head driven tool in Y Radial angetriebenes Werkzeug 2 Ausgaenge in Y		NKM090.2.00
MODULO MOTORIZZATO RADIALE ORIENTABILE ±30° DISASSATO 30mm Radial ±30°adjustable angle driven tool re-directed by 30mm Radial angetriebenes Werkzeug schwenkbar ±30° achsversetzt um 30mm		NKM135.2.00
MODULO MOTORIZZATO ASSIALE H=55mm Axial driven tool H=55mm Axial angetriebenes Werkzeug H=55mm		NKM150.2.10
MODULO MOTORIZZATO ASSIALE H=75mm Axial driven tool H=75mm Axial angetriebenes Werkzeug H=75mm		NKM150.2.20
MODULO MOTORIZZATO ASSIALE MAGGIORATO H=55mm Axial reinforced driven tool H=55mm Axial angetriebenes Werkzeug vergroessert H=55mm		NKM170.2.10
MODULO MOTORIZZATO ASSIALE MAGGIORATO MTSK H=55mm Axial MTSK reinforced driven tool H=55mm Axial MTSK angetriebenes Werkzeug vergroessert H=55mm		NKM170.2.10.K 
MODULO MOTORIZZATO ASSIALE MAGGIORATO H=75mm Axial reinforced driven tool H=75mm Axial angetriebenes Werkzeug vergroessert H=75mm		NKM170.2.20 
MODULO MOTORIZZATO ASSIALE MAGGIORATO MTSK H=75mm Axial MTSK reinforced driven tool H=75mm Axial MTSK angetriebenes Werkzeug vergroessert H=75mm		NKM170.2.20.K 
MODULO MOTORIZZATO ASSIALE MOLTIPLICATO I=1.3 H=55mm Axial geared-up I=1:3 driven tool H=55mm Axial angetriebenes Werkzeug uebersetzt I=1:3 H=55mm		NKM205.2.10

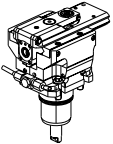
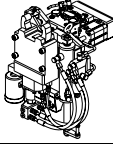
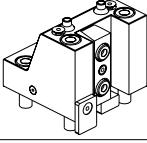
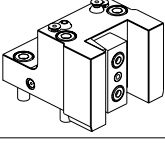
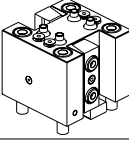
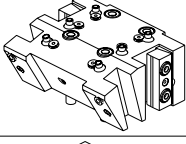
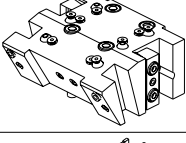
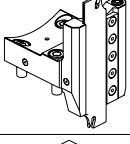
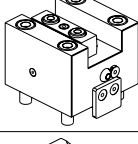
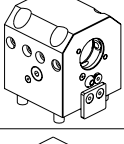
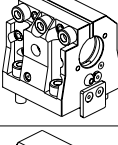
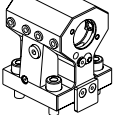

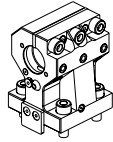
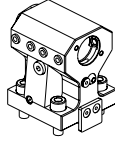
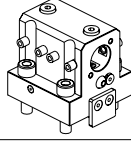
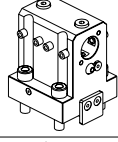
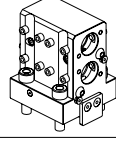
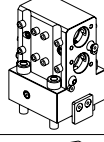
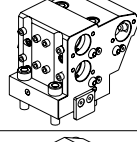
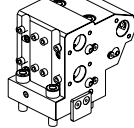
		PAGINA Page Seite
<p>MODULO MOTORIZZATO ASSIALE MOLTIPLICATO I=1:3 H=75mm Axial geared-up I=1:3 driven tool H=75mm Axial angetriebenes Werkzeug uebersetzt I=1:3 H=75mm</p>		NKM205.2.20
<p>MODULO MOTORIZZATO ASSIALE PER POLIGONATURA INTERNA H=55mm Axial driven tool for internal polygon-making H=55mm Axial angetriebenes Werkzeug fuer interne Facettierung H=55mm</p>		NKM230.2.10
<p>MODULO MOTORIZZATO ASSIALE PER POLIGONATURA INTERNA H=75mm Axial driven tool for internal polygon-making H=75mm Axial angetriebenes Werkzeug fuer interne Facettierung H=75mm</p>		NKM230.2.20
<p>MODULO MOTORIZZATO ASSIALE BISPORGENTE H=55mm Axial opposite face twin driven tool H=55mm Axial angetriebenes Werkzeug halb vorspringend H=55mm</p>		NKM240.2.10
<p>MODULO MOTORIZZATO ASSIALE BISPORGENTE H=75mm Axial opposite face twin driven tool H=75mm Axial angetriebenes Werkzeug halb vorspringend H=75mm</p>		NKM240.2.20
<p>MODULO MOTORIZZATO ASSIALE 2 USCITE IN Y H=55mm Axial single side twin head driven tool in Y H=55mm Axial angetriebenes Werkzeug 2 Ausgaenge in Y H=55mm</p>		NKM260.2.10
<p>MODULO MOTORIZZATO ASSIALE 2 USCITE IN Y H=75mm Axial single side twin head driven tool in Y H=75mm Axial angetriebenes Werkzeug 2 Ausgaenge in Y H=75mm</p>		NKM260.2.20
<p>MODULO MOTORIZZATO ORIENTABILE 0-90° 0-90° adjustable angle driven tool Angetriebenes Werkzeug schwenkbar 0-90°</p>		NKM330.2.00
<p>MODULO MOTORIZZATO ORIENTABILE ±90° ±90° adjustable angle driven tool Angetriebenes Werkzeug schwenkbar ±90°</p>		NKM335.2.00 
<p>MODULO MOTORIZZATO ORIENTABILE +/-90° MOLTIPLICATO I=1:2 +/-90° adjustable angle driven tool geared-up I=1:2 Angetriebenes Werkzeug schwenkbar +/-90° uebersetzt I=1:2</p>		NKM336.2.00 
<p>MODULO MOTORIZZATO PORTACREATORE Driven gear hobber Angetriebenes Zahnradwalzfraes-Werkzeug</p>		NKM340.2.00
<p>MODULO MOTORIZZATO STOZZATORE H=66mm Slotting driven tool H=66mm Keilnutenstossmaschine H=66mm</p>		NKM360.2.00 

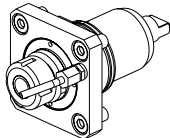
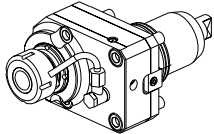
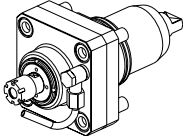
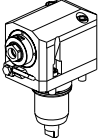
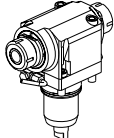

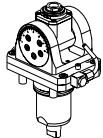
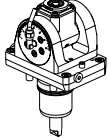
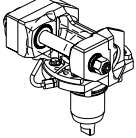
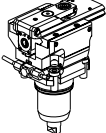

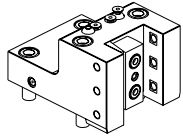
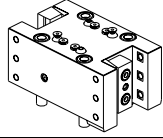
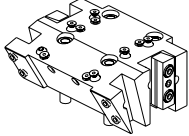
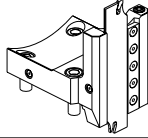
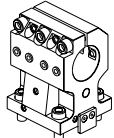
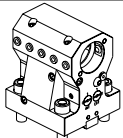
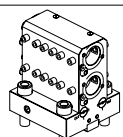
		PAGINA Page Seite
MODULO MOTORIZZATO STOZZATORE H=76mm Slotting driven tool H=76mm Keilnutenstossmaschine H=76mm		NKM360.2.10 NEW
MODULO MOTORIZZATO PER LUNETTA RETRATTILE (TAGLIA 1) Driven toolholder for sliding steady rest (Size 1) Luenettenwerkzeug zurueck versetzte Version (Grosses 1)		NKM363.2.00 NEW
PORTAUTENSILE RADIALE SINGOLO Radial single static tool Radial Single-Werkzeughalter		NKM420.2.00
PORTAUTENSILE RADIALE SINGOLO Radial single static tool Radial Single-Werkzeughalter		NKM423.2.00
PORTAUTENSILE RADIALE DOPPIO Radial double static tool Radial Doppel-Werkzeughalter		NKM450.2.00
PORTAUTENSILE RADIALE MULTIPLO Radial multiple static tool Radial Mehrfach-Halter		NKM470.2.00
PORTAUTENSILE RADIALE MULTIPLO Radial multiple static tool Radial Mehrfach-Halter		NKM470.2.10
PORTAUTENSILE RADIALE PER LAMA Radial blade holder Radial Abstechhalter		NKM510.2.00
PORTAUTENSILE ASSIALE SINGOLO Axial single static tool Axial Single-Werkzeughalter		NKM550.2.00
PORTAUTENSILE ASSIALE PER BARENO Ø32mm / Ø1 1/4" H=55 mm Axial single boring bar holder Ø32mm / Ø1 1/4" H=55mm Axial Bohrhalter Ø32mm / Ø1 1/4" H=55mm		NKM650.2.10
PORTAUTENSILE ASSIALE PER BARENO Ø32mm / Ø1 1/4" H=55mm Axial single boring bar holder Ø32mm / Ø1 1/4" H=55mm Axial bohrhalter Ø32mm / Ø1 1/4" H=55mm		NKM650.2.20
PORTAUTENSILE ASSIALE PER BARENO Ø40mm / Ø32mm / Ø1 1/4" H=75 mm Axial single boring bar holder Ø40mm / Ø32mm / Ø1 1/4" H=75mm Axial Bohrhalter Ø40mm / Ø32mm / Ø1 1/4" H=75 mm		NKM660.2.10

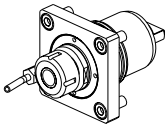
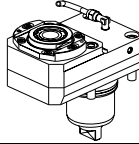
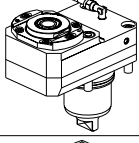
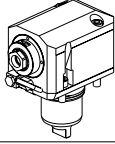
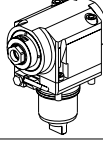
		PAGINA Page Seite
<p>PORTAUTENSILE ASSIALE PER BARENO $\varnothing 40\text{mm}$ / $\varnothing 32\text{mm}$ / $\varnothing 1\frac{1}{4}"$ H=75mm Axial single boring bar holder $\varnothing 40\text{mm}$ / $\varnothing 32\text{mm}$ / $\varnothing 1\frac{1}{4}"$ H=75mm Axial Bohrhälter $\varnothing 40\text{mm}$ / $\varnothing 32\text{mm}$ / $\varnothing 1\frac{1}{4}"$ H=75mm</p>		NKM660.2.20
<p>PORTAUTENSILE ASSIALE PER BARENO $\varnothing 32\text{mm}$ H=80mm Axial single boring bar holder $\varnothing 32\text{mm}$ H=80mm Axial Bohrhälter $\varnothing 32\text{mm}$ H=80mm</p>		NKM665.2.10
<p>PORTAUTENSILE ASSIALE PER BARENO $\varnothing 25\text{mm}$ / $\varnothing 1"$ H=55mm Axial single boring bar holder $\varnothing 25\text{mm}$ / $\varnothing 1"$ H=55mm Axial Bohrhälter $\varnothing 25\text{mm}$ / $\varnothing 1"$ H=55mm</p>		NKM670.2.10
<p>PORTAUTENSILE ASSIALE PER BARENO $\varnothing 25\text{mm}$ / $\varnothing 1"$ H=75mm Axial single boring bar holder $\varnothing 25\text{mm}$ / $\varnothing 1"$ H=75mm Axial Bohrhälter $\varnothing 25\text{mm}$ / $\varnothing 1"$ H=75mm</p>		NKM680.2.10
<p>PORTAUTENSILE ASSIALE PER BARENO 2 POSIZIONI $\varnothing 25\text{mm}$ / $\varnothing 1"$ Axial double boring bar holder $\varnothing 25\text{mm}$ / $\varnothing 1"$ Axial Bohrhälter 2 Positionen $\varnothing 25\text{mm}$ / $\varnothing 1"$</p>		NKM864.2.00
<p>PORTAUTENSILE ASSIALE PER BARENO 2 POSIZIONI $\varnothing 25\text{mm}$ / $\varnothing 1"$ Axial double boring bar holder $\varnothing 25\text{mm}$ / $\varnothing 1"$ Axial Bohrhälter 2 Positionen $\varnothing 25\text{mm}$ / $\varnothing 1"$</p>		NKM864.2.10
<p>PORTAUTENSILE ASSIALE PER BARENO 3 POSIZIONI $\varnothing 25\text{mm}$ / $\varnothing 1"$ Axial 3 position boring bar holder $\varnothing 25\text{mm}$ / $\varnothing 1"$ Axial Bohrhälter 3 Positionen $\varnothing 25\text{mm}$ / $\varnothing 1"$</p>		NKM884.2.00
<p>PORTAUTENSILE ASSIALE PER BARENO 3 POSIZIONI $\varnothing 20\text{mm}$ / $\varnothing 25\text{mm}$ Axial 3 position boring bar holder $\varnothing 20\text{mm}$ / $\varnothing 25\text{mm}$ Axial Bohrhälter 3 Positionen $\varnothing 20\text{mm}$ / $\varnothing 25\text{mm}$</p>		NKM886.2.00

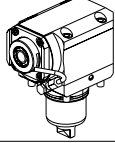
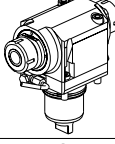
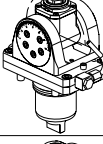
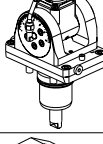
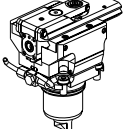
		PAGINA Page Seite
MODULO MOTORIZZATO RADIALE Radial driven tool Radial angetriebenes Werkzeug		NKM010.3.00
MODULO MOTORIZZATO RADIALE MOLTIPLICATO I=1:2 DISASSATO IN Z 45mm Radial geared-up I=1:2 driven tool re-directed in Z by 45mm Radial angetriebenes Werkzeug uebersetzt I=1:2 achsversetzt in Z um 45mm		NKM030.3.30
MODULO MOTORIZZATO RADIALE MOLTIPLICATO I=1:3 Radial geared-up I=1:3 driven tool Radial angetriebenes Werkzeug uebersetzt I=1:3		NKM055.3.00
MODULO MOTORIZZATO ASSIALE H=65mm Axial driven tool H=65mm Axial angetriebenes Werkzeug H=65mm		NKM150.3.10
MODULO MOTORIZZATO ASSIALE BISPORGENTE H=65 mm Axial opposite face twin driven tool H=65mm Axial angetriebenes Werkzeug halb vorspringend H=65mm		NKM240.3.10
MODULO MOTORIZZATO ORIENTABILE 0-90° 0-90° adjustable angle driven tool Angetriebenes Werkzeug schwenkbar 0-90°		NKM330.3.00 NEW
MODULO MOTORIZZATO ORIENTABILE ±90° ±90° adjustable angle driven tool Angetriebenes Werkzeug schwenkbar ±90°		NKM335.3.00 NEW
MODULO MOTORIZZATO ORIENTABILE +/-90° MOLTIPLICATO I=1:2 +/-90° adjustable angle driven tool geared-up I=1:2 Angetriebenes Werkzeug schwenkbar +/-90° uebersetzt I=1:2		NKM336.3.00 NEW
MODULO MOTORIZZATO PORTACREATORE Driven gear hobber Angetriebenes Zahnradwaelzfraes-Werkzeug		NKM340.3.00
MODULO MOTORIZZATO STOZZATORE Slotting driven tool Keilnutenstossmaschine		NKM360.3.00 NEW

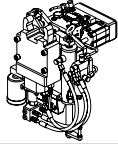
		PAGINA Page Seite
<p>PORTAUTENSILE RADIALE SINGOLO Radial single static tool Radial Single-Werkzeughalter</p>		NKM423.3.00
<p>PORTAUTENSILE RADIALE DOPPIO Radial double static tool Radial Doppel-Werkzeughalter</p>		NKM453.3.00
<p>PORTAUTENSILE RADIALE MULTIPO Radial multiple static tool Radial Mehrfach-Halter</p>		NKM470.3.00
<p>PORTAUTENSILE RADIALE PER LAMA Radial blade holder Radial Abstechhalter</p>		NKM510.3.00
<p>PORTAUTENSILE ASSIALE PER BARENO Ø40mm / Ø50mm H=90mm Axial single boring bar holder Ø40mm / Ø50mm H=90mm Axial Bohrhalter Ø40mm / Ø50mm H=90mm</p>		NKM610.3.20
<p>PORTAUTENSILE ASSIALE PER BARENO Ø40mm / Ø32mm H=90mm Axial single boring bar holder Ø40mm / Ø32mm H=90mm Axial Bohrhalter Ø40mm / Ø32mm H=90mm</p>		NKM630.3.10
<p>PORTAUTENSILE ASSIALE PER BARENO 2 POSIZIONI Ø25mm Axial double boring bar holder Ø25mm Axial Bohrhalter 2 Positionen Ø25mm</p>		NKM864.3.00

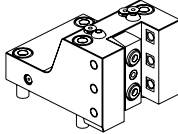
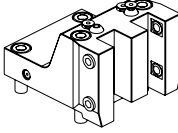
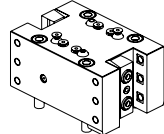
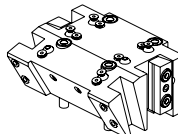
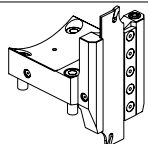
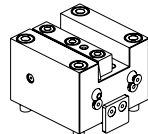
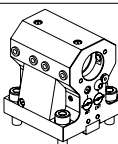
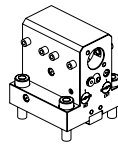
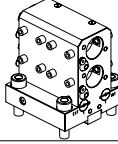
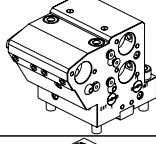
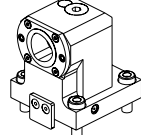
		PAGINA Page Seite
MODULO MOTORIZZATO RADIALE Radial driven tool Radial angetriebenes Werkzeug		NKM010.4.00
MODULO MOTORIZZATO RADIALE RIDOTTO I=2:1 DISASSATO IN Z 68mm Radial geared-down I=2:1 driven tool re-directed in Z by 68mm Radial angetriebenes Werkzeug unterersetzt I=2:1 achsversetzt in Z um 68mm	 NEW	NKM030.4.20
MODULO MOTORIZZ. RADIALE MOLTIPLICATO I=1:2 DISASSATO IN Z 68mm Radial geared-up I=1:2 driven tool re-directed in Z by 68mm Radial angetriebenes Werkzeug uebersetzt I=1:2 achsversetzt in Z um 68mm	 NEW	NKM033.4.30
MODULO MOTORIZZATO ASSIALE H=55mm Axial driven tool H=55mm Axial angetriebenes Werkzeug H=55mm		NKM150.4.10
MODULO MOTORIZZATO ASSIALE H=65mm Axial driven tool H=65mm Axial angetriebenes Werkzeug H=65mm		NKM150.4.20
MODULO MOTORIZZATO ASSIALE H=65mm Axial driven tool H=65mm Axial angetriebenes Werkzeug H=65mm	 NEW	NKM150.4.21
MODULO MOTORIZZATO ASSIALE MOLTIPLICATO I=1:2 Axial geared-up I=1:2 driven tool Axial angetriebenes Werkzeug uebersetzt I=1:2	 NEW	NKM200.4.10
MODULO MOTORIZZATO ASSIALE BISPORGENTE H=65mm Axial opposite face twin driven tool H=65mm Axial angetriebenes Werkzeug halb vorspringend H=65mm		NKM240.4.10
MODULO MOTORIZZATO ORIENTABILE ±90° ±90° adjustable angle driven tool Angetriebenes Werkzeug schwenkbar ±90°	 NEW	NKM335.4.00
MODULO MOTORIZZATO ORIENTABILE +/-90° MOLTIPLICATO I=1:2 +/-90° adjustable angle driven tool geared-up I=1:2 Angetriebenes Werkzeug schwenkbar +/-90° uebersetzt I=1:2	 NEW	NKM336.4.00
MODULO MOTORIZZATO PORTACREATORE Driven gear hobber Angetriebenes Zahnradwaelzfraes-Werkzeug		NKM340.4.00
MODULO MOTORIZZATO STOZZATORE Slotting driven tool Keilnutenstossmaschine	 NEW	NKM360.4.00

		PAGINA Page Seite
MODULO MOTORIZZATO PER LUNETTA RETRATTILE (TAGLIA 1) Driven toolholder for sliding steady rest (Size 1) Luenettenwerkzeug zurueck versetzte Version (Groesse 1)		NKM363.4.00 
PORTAUTENSILE RADIALE SINGOLO Radial single static tool Radial Single-Werkzeughalter		NKM423.4.00
PORTAUTENSILE RADIALE SOVRAPPOSTO Radial single side twin static tool Radial Werkzeughalter ueberlagert		NKM440.4.00
PORTAUTENSILE RADIALE DOPPIO Radial double static tool Radial Doppel-Werkzeughalter		NKM453.4.00
PORTAUTENSILE RADIALE MULTIPLO Radial multiple static tool Radial Mehrfach-Halter		NKM470.4.00
PORTAUTENSILE RADIALE PER LAMA Radial blade holder Radial Abstechhalter		NKM510.4.00
PORTAUTENSILE ASSIALE SINGOLO Axial single static tool Axial Single-Werkzeughalter		NKM552.4.00
PORTAUTENSILE ASSIALE PER BARENO Ø32mm / Ø40mm H=75mm Axial single boring bar holder Ø32mm / Ø40mm H=75mm Axial Bohrhalter Ø32mm / Ø40mm H=75mm		NKM650.4.10
PORTAUTENSILE ASSIALE PER BARENO Ø25mm / Ø1" H=75mm Axial single boring bar holder Ø25mm / Ø1" H=75mm Axial Bohrhalter Ø25mm / Ø1" H=75mm		NKM670.4.10
PORTAUTENSILE ASSIALE PER BARENO 2 POSIZIONI Ø25mm / Ø1" Axial double boring bar holder Ø25mm / Ø1" Axial Bohrhalter 2 Positionen Ø25mm / Ø1"		NKM864.4.00
PORTAUTENSILE ASSIALE PER BARENO 3 POSIZIONI Ø25mm / Ø1" Axial 3 position boring bar holder Ø25mm / Ø1" Axial Bohrhalter 3 Positionen Ø25mm / Ø1"		NKM884.4.00
PORTAUTENSILE ASSIALE SINGOLO COROMANT CAPTO® Axial single static tool COROMANT CAPTO® Axial Single-Werkzeughalter COROMANT CAPTO®		NKM550.D.40 

ATTENZIONE - ATTENTION - ACHTUNG

- FINO AD ESAURIMENTO SCORTE
- clearance sale
- solange vorrat

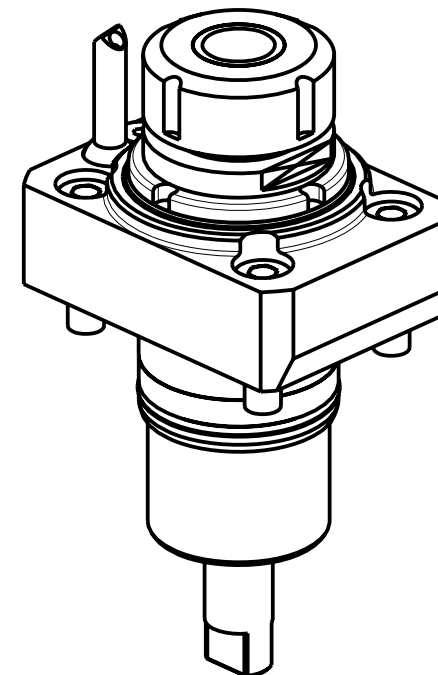
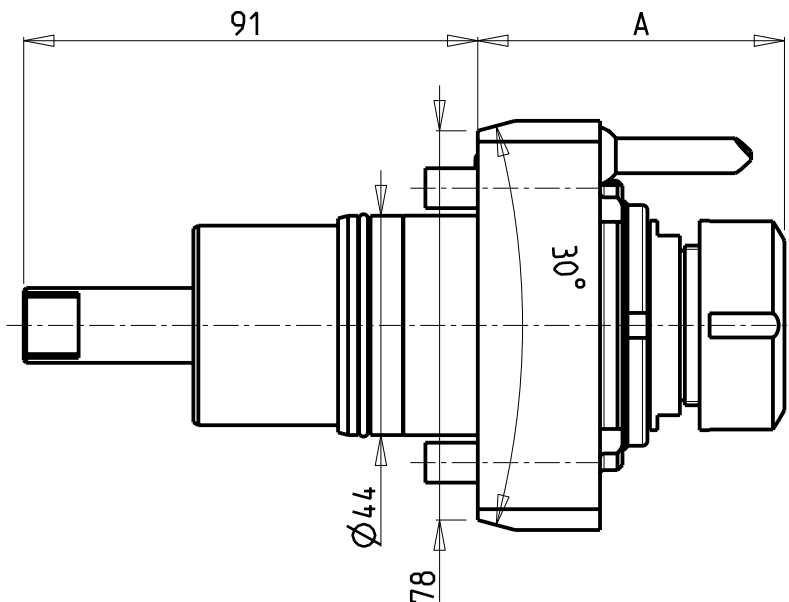
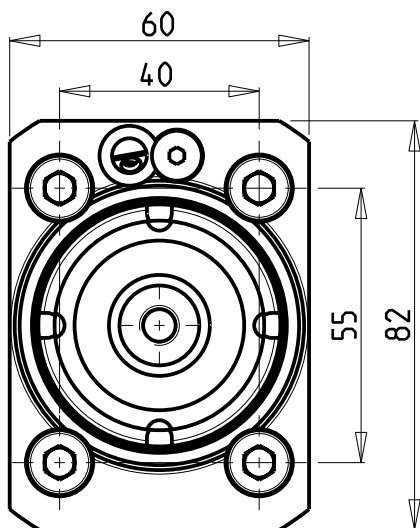

Cod. MT	Mandrino Spindel Spindel	I	RPM	Coppia Max Max Torque Max Drehmoment	Lubrificazione int. Coolant through Innenkuhlung	Lubrificazione est. Ext. coolant Aussenkuhlung	A	CHIAVI NON INCLUSE Keys not included Schluessel nicht einbegriffen	
NKM0230125	ER25	1:1	6000	35Nm		X	61.46	CHUB36	CHSTER25
NKM0230225	ER25	1:1	6000	35Nm	P=30bar		64.66	CHUB36	CHSTER25
NKM0230520	ER A 20	1:1	6000	35Nm		X	55.23	CHUB36	CHUB22
NKM0230620	ER A 20	1:1	6000	35Nm	P=30bar		55.23	CHUB36	CHUB22

NAKAMURA-TOME

MOD: WT100 - WY100 - NTY3 - NTJ100

MODULO MOTORIZZATO RADIALE

Radial driven tool

Radial angetriebenes Werkzeug

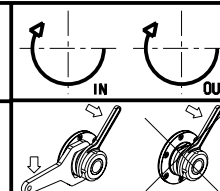

M.T. srl

Via Casino Albini 480
Tel. 0541/956034-957884
Fax 0541/956341

47842 S. GIOVANNI IN M. (RN)
e-mail: mtma@mtmarchetti.com
http://www.mtmarchetti.com

PRODUZIONE MODULI ROTANTI



PAGINA NKM010-1-00

CUSCINETTI MAGGIORATI PER LAVORAZIONI PESANTI

Reinforced bearings for
heavy machining

Vergroesserte Lager fuer
schwerere Bearbeitungen

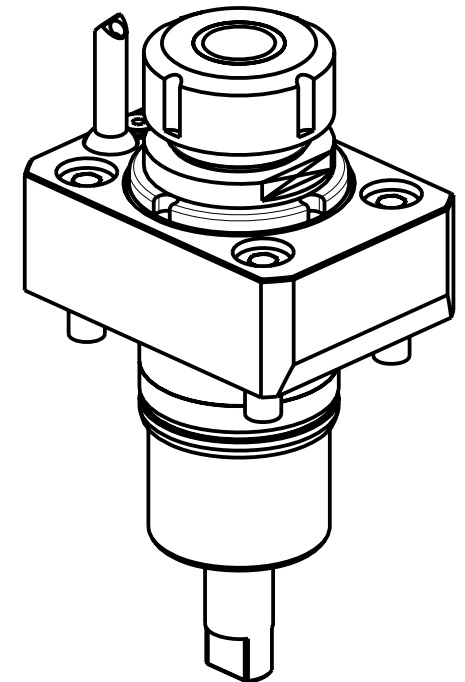
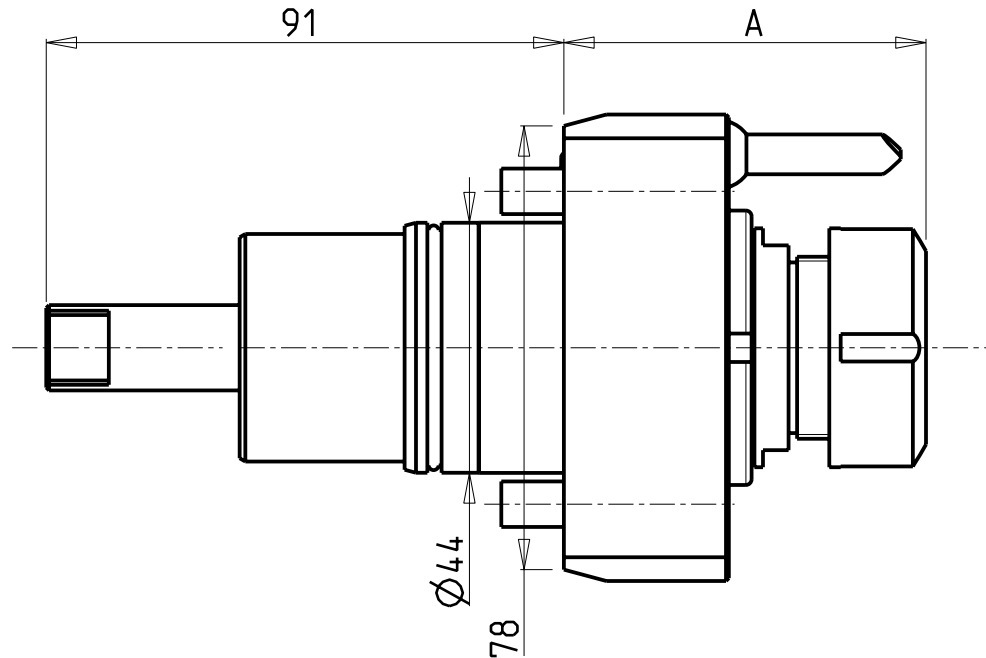
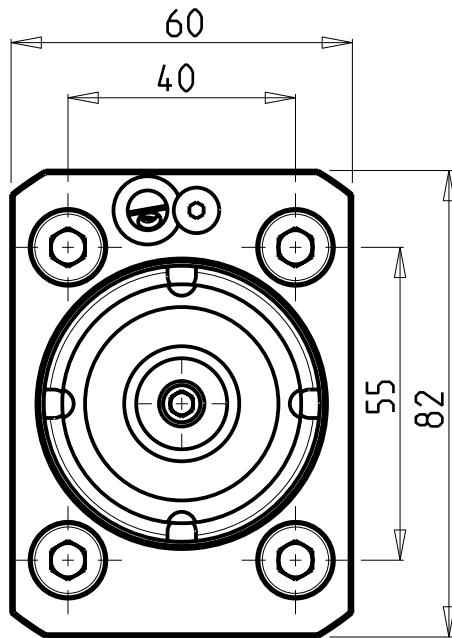

Cod. MT	Mandrino Spindle Spindel	I	RPM	Coppia Max Max Torque Max Drehmoment	Lubrificazione int. Coolant through Innenkueltung	Lubrificazione est. Ext. coolant Aussenkueltung	A	CHIAVI NON INCLUSE Keys not included Schluessel nicht einbegriffen	
NKM0690520	ERA20	1:1	6000	35Nm		X	46	CHUB36	CHUB22
NKM0690620	ERA20	1:1	6000	35Nm	P=30bar	X	52	CHUB36	CHUB22
NKM0690125	ER25	1:1	6000	35Nm		X	63.66	CHUB36	CHSTER25
NKM0690225	ER25	1:1	6000	35Nm	P=30bar	X	69.66	CHUB36	CHSTER25

NAKAMURA-TOME

MOD: WT100 - WY100 - NTY3 - NTJ100

MODULO MOTORIZZATO RADIALE

Radial driven tool

Radial angetriebenes Werkzeug

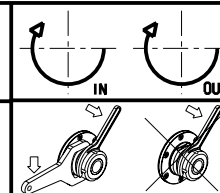

M.T. srl

Via Casino Albini 480
Tel. 0541/956034-957884

Fax 0541/956341

47842 S. GIOVANNI IN M. (RN)

e-mail: mtma@mtmarchetti.com

http://www.mtmarchetti.com

PRODUZIONE MODULI ROTANTI



PAGINA NKM020-1-00

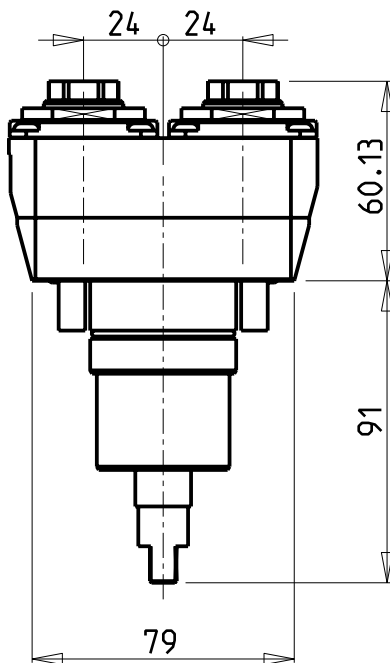
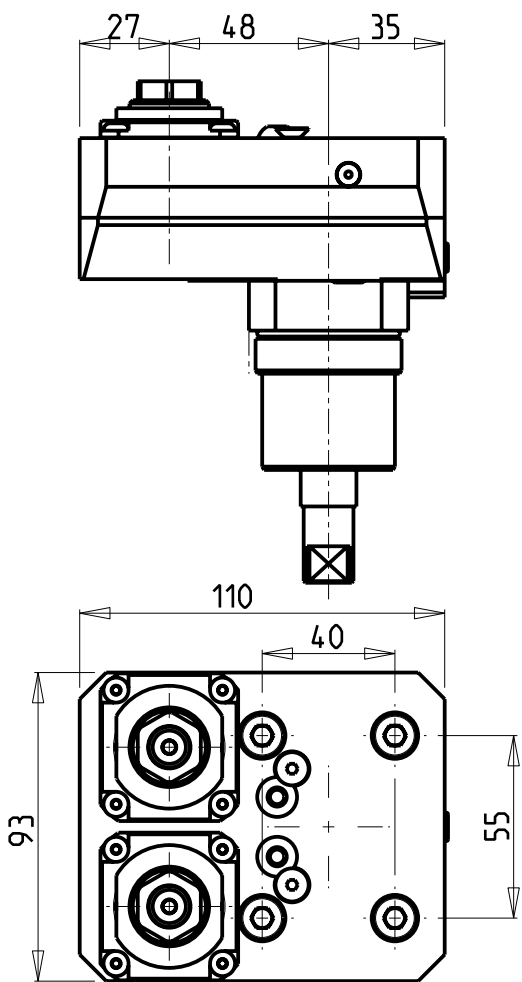

ATTENZIONE - ATTENTION - ACHTUNG

- Per lo smontaggio degli utensili utilizzare sempre la chiave di contrasto come indicato nel manuale d'uso.
- For disassembly of the tools use always the contrast key as mentioned in the user instructions.
- Fuer das Abmontieren der Werkzeuge immer den Gegenschlüssel benutzen wie in der Bedienungsanleitung erwäehnt.

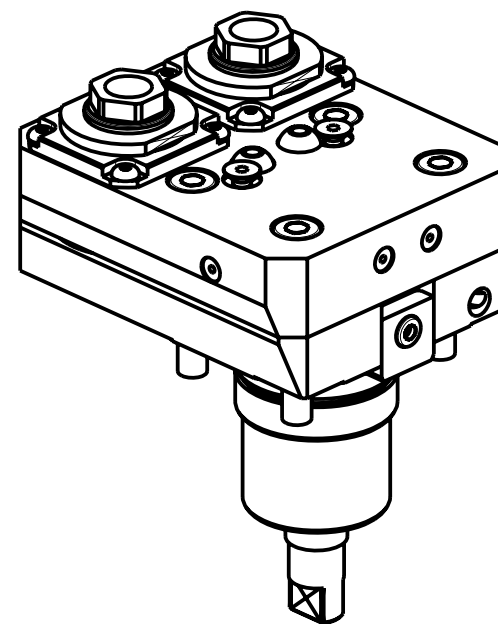

Cod. MT	Mandrino Spindle Spindel	I	RPM	Coppia Max Max Torque Max Drehmoment	Lubrificazione est. Ext. coolant Aussenkuehlung	CHIAVI NON INCLUSE Keys not included Schluesssel nicht inbegriffen	
NKM0190216	ER A 16	1:1	6000	25Nm	X	CHUB32	CHUB19_SP3

NAKAMURA-TOME
MOD. WT100 - WY100 - NTY3 - NTJ100

MODULO MOTORIZZATO RADIALE 2 USCITE IN Y
Radial single side twin head driven tool in Y
Radial angetriebenes Werkzeug 2 Ausgaenge in Y

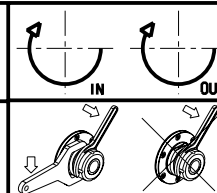

M.T. srl
Via Casino Albini 480
Tel. 0541/956034-957884
Fax 0541/956341
47842 S. GIOVANNI IN M. (RN)
e-mail: mtma@mtmarchetti.com
http://www.mtmarchetti.com

PRODUZIONE MODULI ROTANTI



PAGINA NKM090-1-00

ATTENZIONE - ATTENTION - ACHTUNG

- Per lo smontaggio degli utensili utilizzare sempre la chiave di contrasto come indicato nel manuale d'uso.
- For disassembly of the tools use always the contrast key as mentioned in the user instructions.
- Fuer das Abmontieren der Werkzeuge immer den Gegenschlüssel benutzen wie in der Bedienungsanleitung erwäehnt.

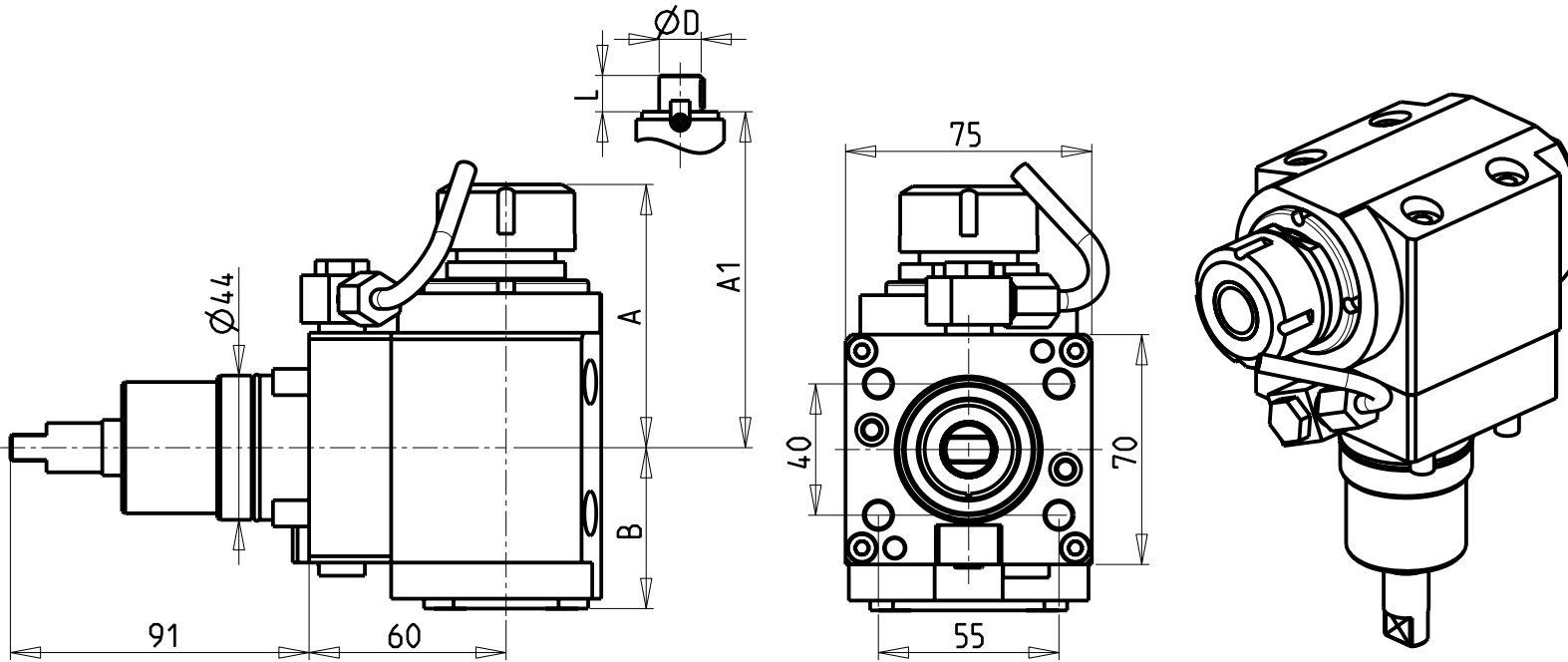

- Chiave inclusa
- Key included
- Schlüssel inbegriffen

Cod. MT	Mandrino Spindel Spindel	I	RPM	Coppia Max Max Torque Max Drehmoment	Reversibile lato mandrino/contromandrino Reversible sub/main spindle side Umkehrbare Spindel-seite/ Gegenspindel-seite	Lubr. interna Coolant through Innenkuhlung	Lubr. esterna Ext. coolant Aussenkuhlung	A	A1	B	D	L	CHIAVI NON INCLUSE Keys not included Schlüssel nicht einbegriffen	
NKM0240125	ER25	1:1	6000	35Nm	X		X	80.16	-	49	-	-	CHUB36	CHSTER25
NKM0240225	ER25	1:1	6000	35Nm	X	P=70bar	X	80.16	-	59	-	-	CHUB36	CHSTER25
NKM0240520	ER A 20	1:1	6000	35Nm	X		X	69.23	-	49	-	-	CHUB36	CHUB22
NKM0240620	ER A 20	1:1	6000	35Nm	X	P=70bar	X	69.23	-	59	-	-	CHUB36	CHUB22
NKM0241617	Ø16x17	1:1	6000	35Nm	X		X	-	63	49	16	17	CHUB36	CH_VTCROCE_M08 •
NKM0242219	Ø22x19	1:1	6000	35Nm	X		X	-	63	49	22	19	CHUB36	CH_VTCROCE_M10 •

NAKAMURA-TOME
 MOD: WT100 - WY100 - NTY3 - NTJ100
 MODULO MOTORIZZATO ASSIALE
 Axial driven tool
 Axial angetriebenes Werkzeug

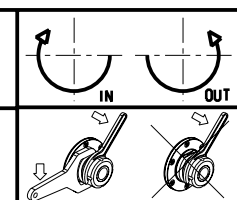

M.T. srl
 Via Casino Albini 480
 Tel. 0541/956034-957884
 Fax 0541/956341
 47842 S. GIOVANNI IN M. (RN)
 e-mail: mtma@mtmarchetti.com
 http://www.mtmarchetti.com

PRODUZIONE MODULI ROTANTI

PAGINA NKM150-1-10

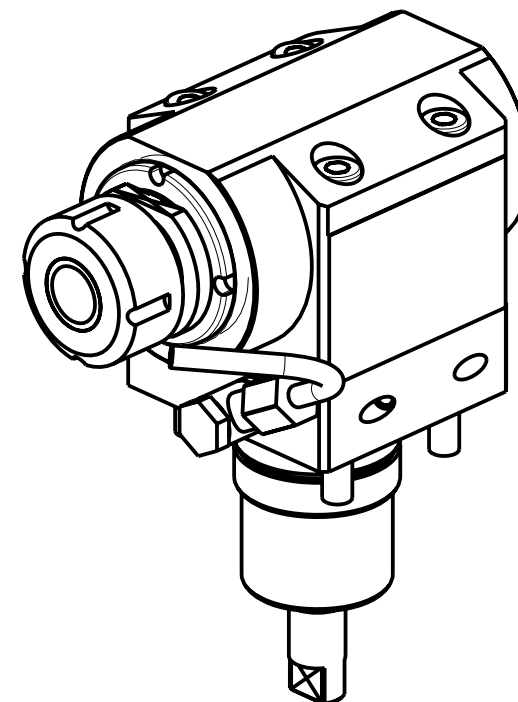
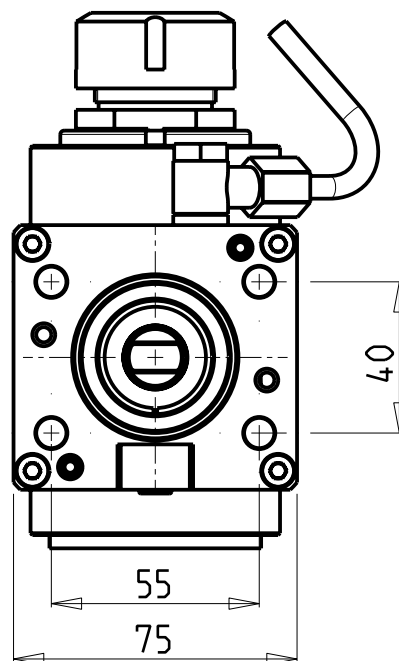
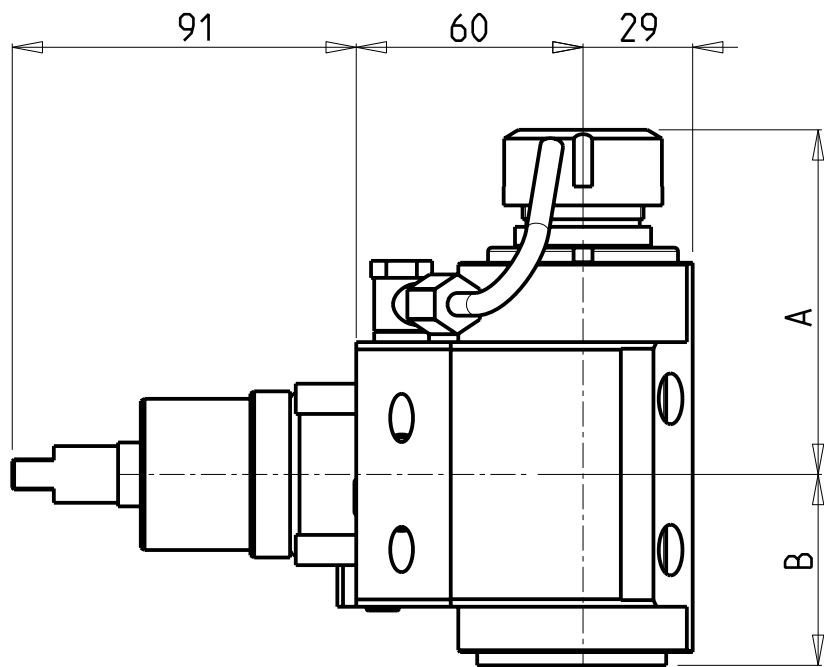

Cod. MT	Mandrino Spindle Spindel	I	RPM	Coppia Max Max Torque Max Drehmoment	Reversibile lato mandrino/contromandrino Reversible sub/main spindle side Umkehrbare Spindelseite/Gegenspindelseite	Lubrificazione int. Coolant through Innenkuehlung	Lubrificazione est. Ext. coolant Aussenkuehlung	A	B	CHIAVI INCLUSE Keys included Schluessel einbegriffen	
NKM0710320	ERA20	1:2	12000	20Nm	X		X	72.5	50.5	CHUB22	CHUB36
NKM0710420	ERA20	1:2	12000	20Nm	X	P=70bar	X	72.5	58.5	CHUB22	CHUB36
NKM0710125	ER25	1:2	12000	20Nm	X		X	91.16	50.5	CHSTER25	CHUB36
NKM0710225	ER25	1:2	12000	20Nm	X	P=70bar	X	91.16	58.5	CHSTER25	CHUB36

NAKAMURA
 MOD: WT100 - WY100 - NTY3 - NTJ100

MODULO MOTORIZZATO ASSIALE MOLTIPLICATO I=1:2
 Axial geared-up I=1:2 driven tool
 Axial angetriebenes Werkzeug uebersetzt I=1:2

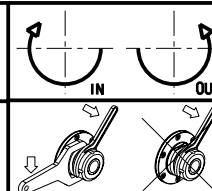

M.T. srl
 Via Casino Albini 480
 Tel. 0541/956034-957884
 Fax 0541/956341
 47842 S. GIOVANNI IN M. (RN)
 e-mail: mtma@mtmarchetti.com
 http://www.mtmarchetti.com

PRODUZIONE MODULI ROTANTI



PAGINA NKM200-1-10

ATTENZIONE - ATTENTION - ACHTUNG

- Per lo smontaggio degli utensili utilizzare sempre la chiave di contrasto come indicato nel manuale d'uso.
- For disassembly of the tools use always the contrast key as mentioned in the user instructions.
- Fuer das Abmontieren der Werkzeuge immer den Gegenschlüssel benutzen wie in der Bedienungsanleitung erwäehnt.

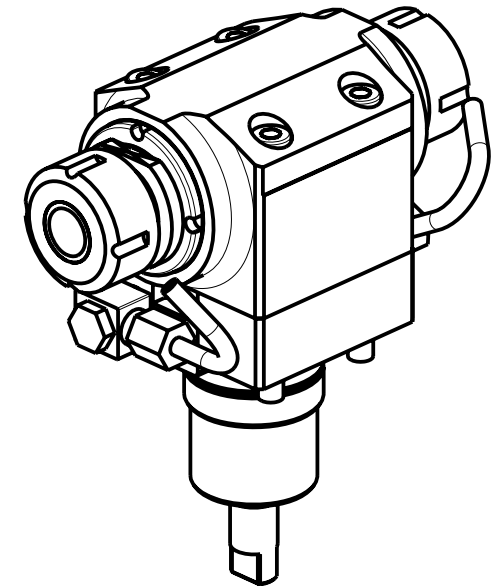
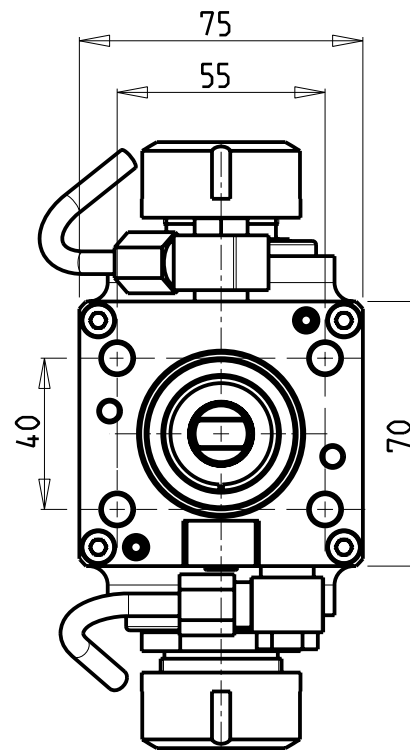
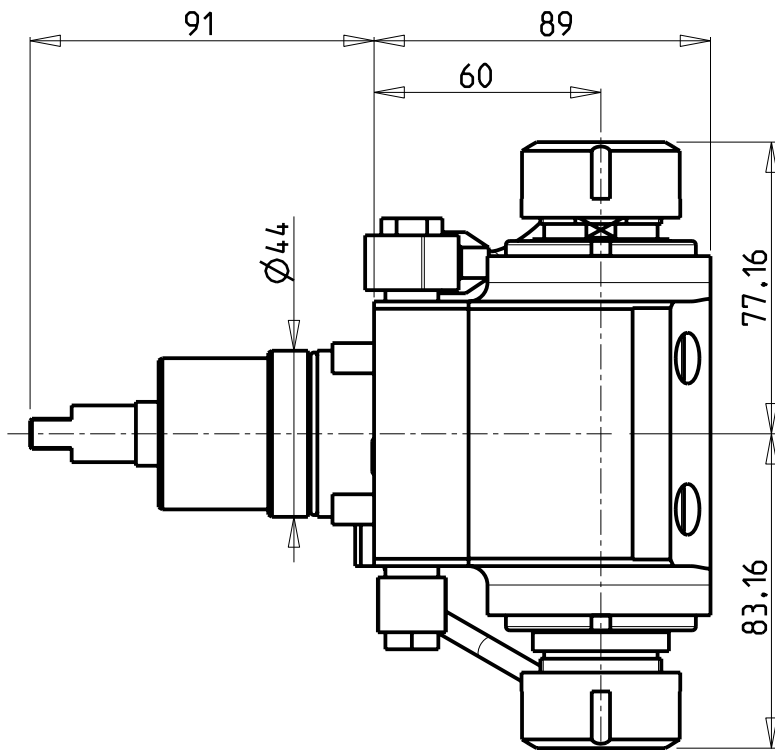

Cod. MT	Mandrino Spindle Spindel	I	RPM	Coppia Max Max Torque Max Drehmoment	Reversibile lato mandrino/contromandrino Reversible sub/main spindle side Umkehrbare Spindel-seite/ Gegenspindel-seite	Lubrificazione est. Ext. coolant Aussenkuehlung	CHIAVI NON INCLUSE Keys not included Schluesssel nicht einbegriffen		
NKM0640225	ER25+ER25	1:1	6000	35Nm	X	X	CHSTER25	CHUB29	CHUB36

NAKAMURA-TOME

MOD: WT100 - WY100 - NTY3 - NTJ100

MODULO MOTORIZZATO ASSIALE BISPORGENTE H=60mm

Axial opposite face twin driven tool H=60mm

Axial angetriebenes Werkzeug halb vorspringend H=60mm

M.T. srl

Via Casino Albini 480
Tel. 0541/956034-957884
Fax 0541/956341
47842 S. GIOVANNI IN M. (RN)
e-mail: mtma@mtmarchetti.com
http://www.mtmarchetti.com

PRODUZIONE MODULI ROTANTI



PAGINA NKM240-1-10

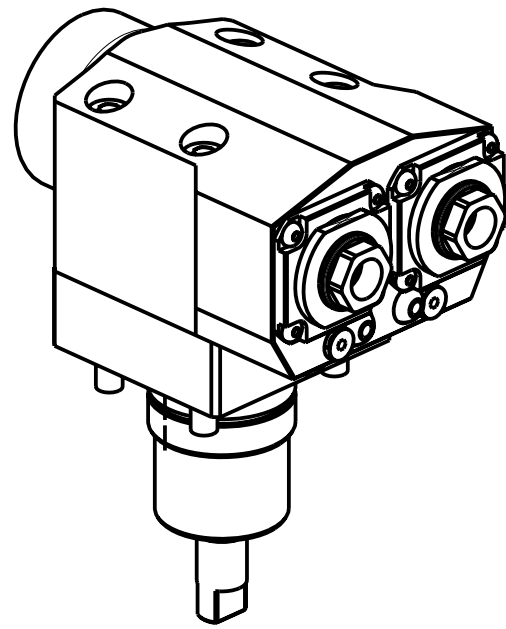
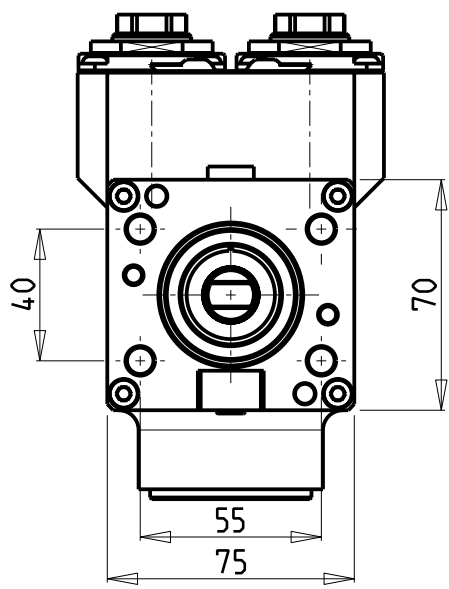
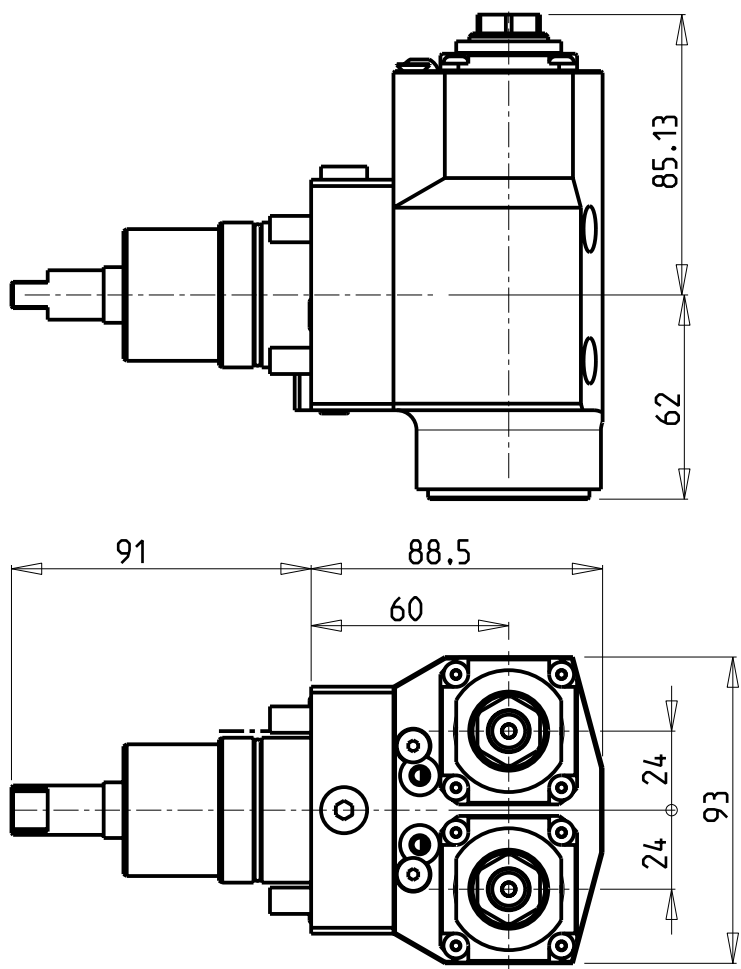

ATTENZIONE - ATTENTION - ACHTUNG

- Per lo smontaggio degli utensili utilizzare sempre la chiave di contrasto come indicato nel manuale d'uso.
- For disassembly of the tools use always the contrast key as mentioned in the user instructions.
- Fuer das Abmontieren der Werkzeuge immer den Gegenschlüssel benutzen wie in der Bedienungsanleitung erwäehnt.

Cod. MT	Mandrino Spindel Spindel	I	RPM	Coppia Max Max Torque Max Drehmoment	Reversibile lato mandrino/contromandrino Reversible sub/main spindle side Umkehrbare Spindelseite/Gegenspindelseite	Lubrificazione est. Ext. coolant Aussenkuehlung	CHIAVI NON INCLUSE Keys not included Schluessel nicht inbegriffen
NKM0200216	ER A 16	1:1	6000	25Nm	X	X	CHUB32 CHUB19_SP3

NAKAMURA-TOME
 MOD. WT100 - WY100 - NTY3 - NTJ100

MODULO MOTORIZZATO ASSIALE 2 USCITE IN Y
 Axial single side twin head driven tool in Y
 Axial angetriebenes Werkzeug 2 Ausgaenge in Y

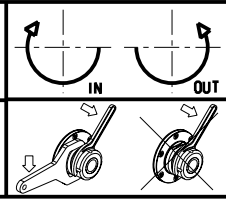

M.T. srl
 Via Casino Albini 480
 Tel. 0541/956034-957884
 Fax 0541/956341
 47842 S. GIOVANNI IN M. (RN)
 e-mail: mtma@mtmarchetti.com
 http://www.mtmarchetti.com

PRODUZIONE MODULI ROTANTI



PAGINA NKM260-1-20

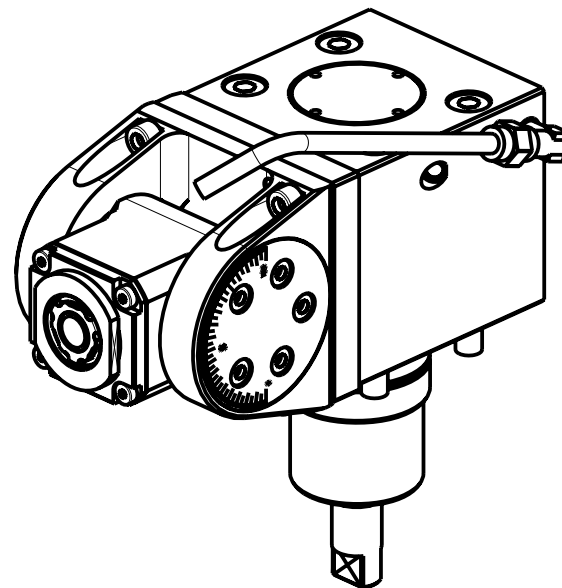
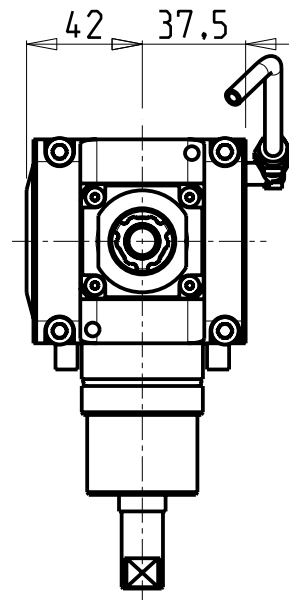
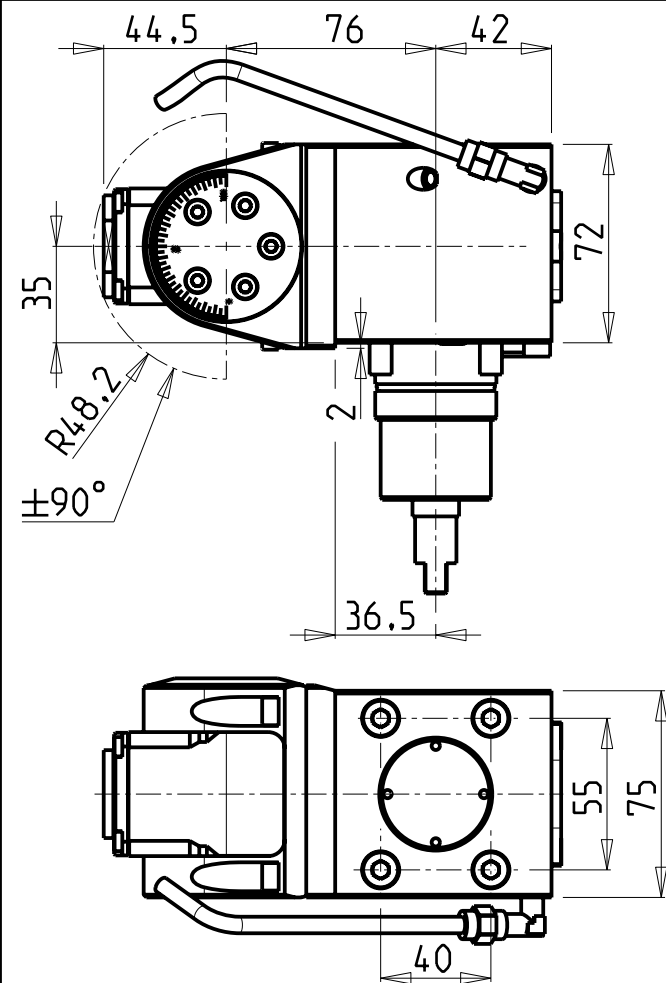

ATTENZIONE - ATTENTION - ACHTUNG

- Con l'utensile orientato a 90°, non è possibile eseguire lavorazioni a centro-pezzo!
- It is not possible to make machining operations at the center of the part with tool oriented at 90°.
- Mit einem Werkzeug um 90° orientiert, ist es nicht möglich, Verarbeitung von der Werkzeug-Mitte auszuführen.

ATTENZIONE - ATTENTION - ACHTUNG

- Per lo smontaggio degli utensili utilizzare sempre la chiave di contrasto come indicato nel manuale d'uso.
- For disassembly of the tools use always the contrast key as mentioned in the user instructions.
- Fuer das Abmontieren der Werkzeuge immer den Gegenschlüssel benutzen wie in der Bedienungsanleitung erwaeht.

Cod. MT	Mandrino Spindle Spindel	I	RPM	Coppia Max Max Torque Max Drehmoment	Reversibile lato mandrino/contromandrino Reversible sub/main spindle side Umkehrbare Spindelseite/Gegenspindelseite	Lubrificazione est. Ext. coolant Aussenkuhlung	CHIAVI INCLUDE Keys included Schluessel inbegriffen			
NKM0670316	ER A 16	1:1	6000	20Nm	X	X	CHUB19_SP3	CHUB32	CHTAER16ZC	NEW

NAKAMURA-TOME

MOD: WT100 - WY100 - NTY3 - NTJ100

MODULO MOTORIZZATO ORIENTABILE ±90°

±90° adjustable angle driven tool

Angetriebenes Werkzeug schwenkbar ±90°

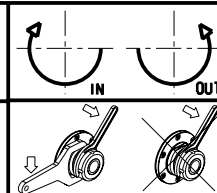

M.T. srl

Via Casino Albini 480
Tel. 0541/956034-957884
Fax 0541/956341

47842 S. GIOVANNI IN M. (RN)
e-mail: mtma@mtmarchetti.com
http://www.mtmarchetti.com

PRODUZIONE MODULI ROTANTI



PAGINA NKM337-1-00

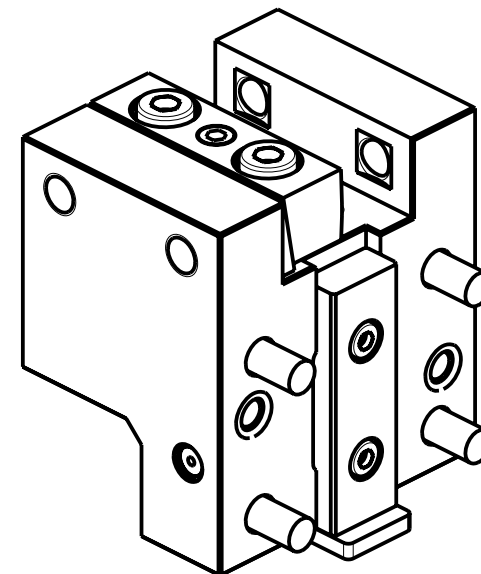
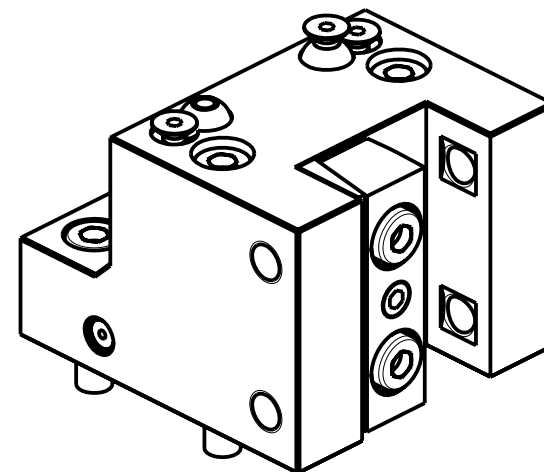
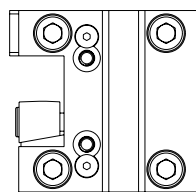
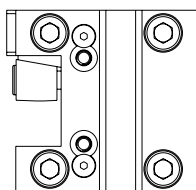
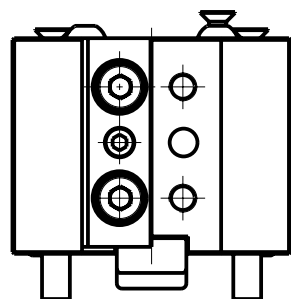
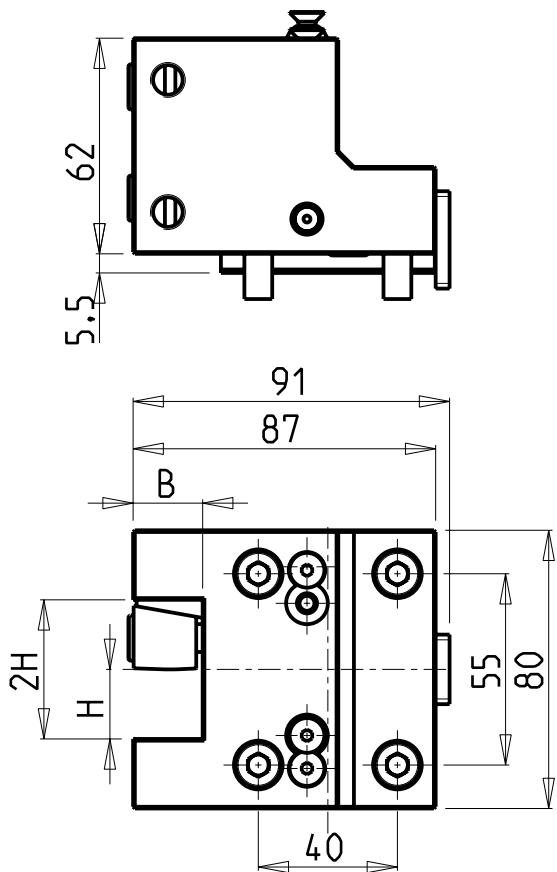

Cod. MT	N°Utensili N°Tools N°Werkzeuge	Reversibile lato mandrino/contromandrino Reversible sub/main spindle side Umkehrbare Spindelseite/ Gegenspindelseite	Misure Dimensions Masse	B	H
NKM0162010	1	X	mm	20	20

NAKAMURA-TOME

MOD: WT100 - WY100 - NTY3 - NTJ100 - SUPER NTMX

PORTAUTENSILE RADIALE SINGOLO

Radial single static tool

Radial Single-Werkzeughalter

M.T. srl

Via Casino Albini 480
Tel. 0541/956034-957884
Fax 0541/956341
47842 S. GIOVANNI IN M. (RN)
e-mail: mtma@mtmarchetti.com
http://www.mtmarchetti.com

PRODUZIONE MODULI ROTANTI



PAGINA NKM420-1-00

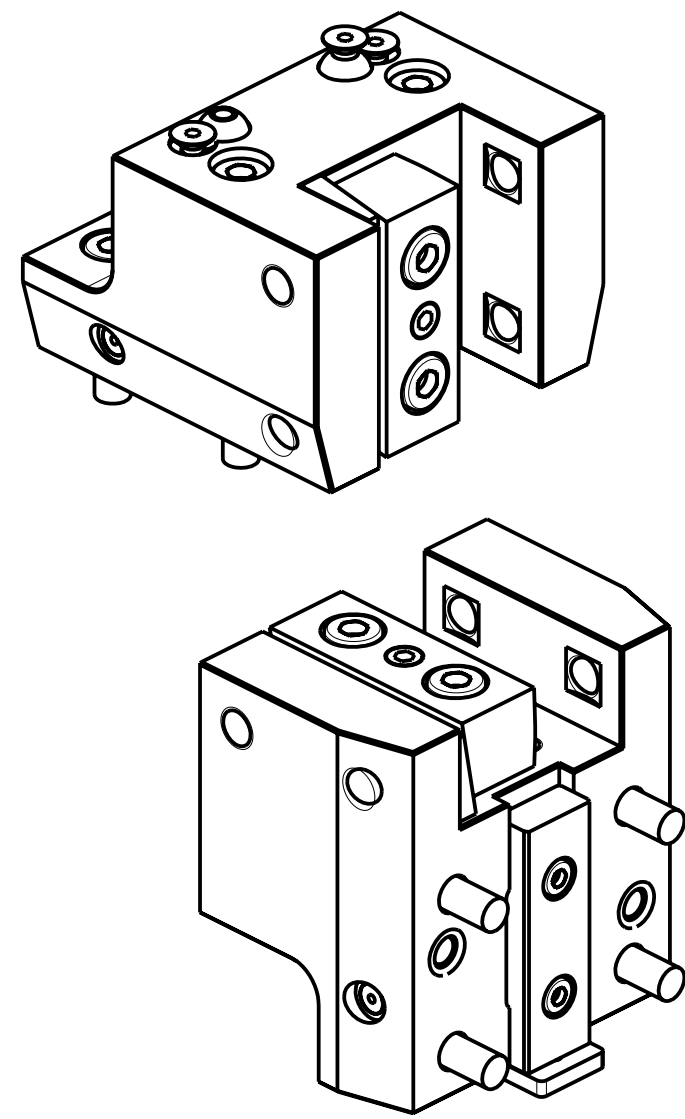
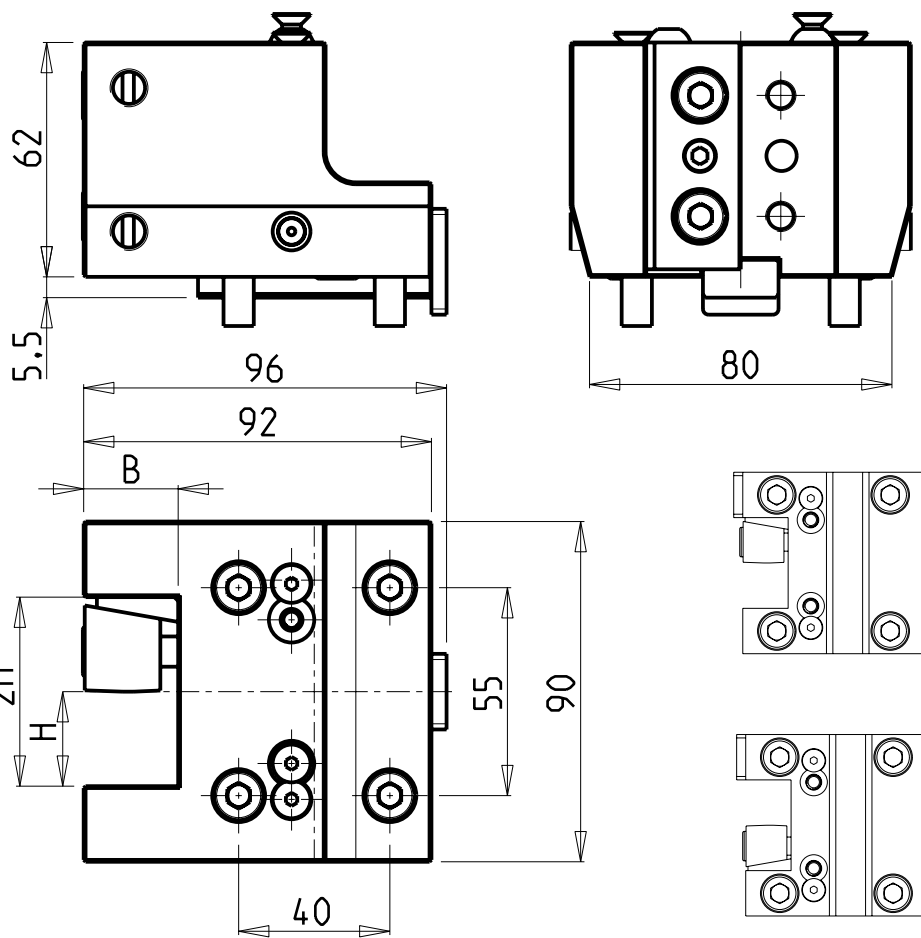

Cod. MT	N°Utensili N° Tools N° Werkzeuge	Reversibile lato mandrino/contromandrino Reversible sub/main spindle side Umkehrbare Spindelseite/ Gegenspindelseite	Misure Dimensions Masse	B	H
NKM0162510	1	X	mm	25	25

NAKAMURA-TOME
 MOD: WT100 - WY100 - NTY3 - NTJ100 - SUPER NTMX
 PORTAUTENSILE RADIALE SINGOLO
 Radial single static tool
 Radial Single-Werkzeughalter



M.T. srl
 Via Casino Albini 480
 Tel. 0541/956034-957884
 Fax 0541/956341
 47842 S. GIOVANNI IN M. (RN)
 e-mail: mtma@mtmarchetti.com
 http://www.mtmarchetti.com

PRODUZIONE MODULI ROTANTI

PAGINA NKM423-1-00

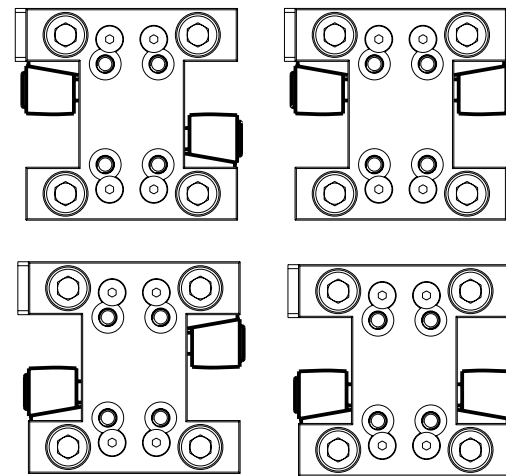
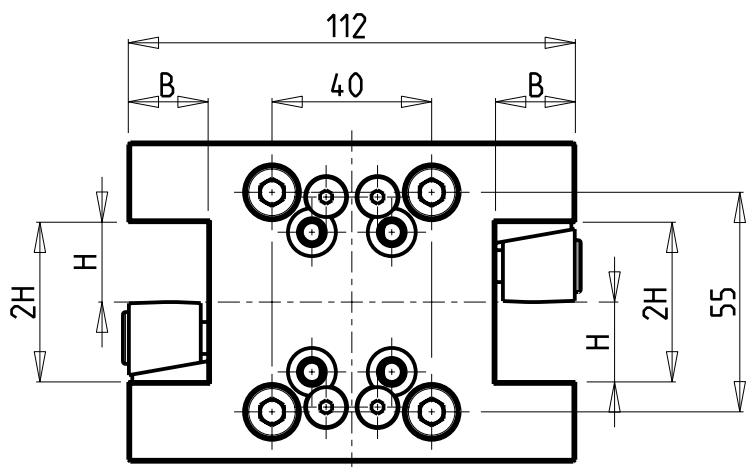
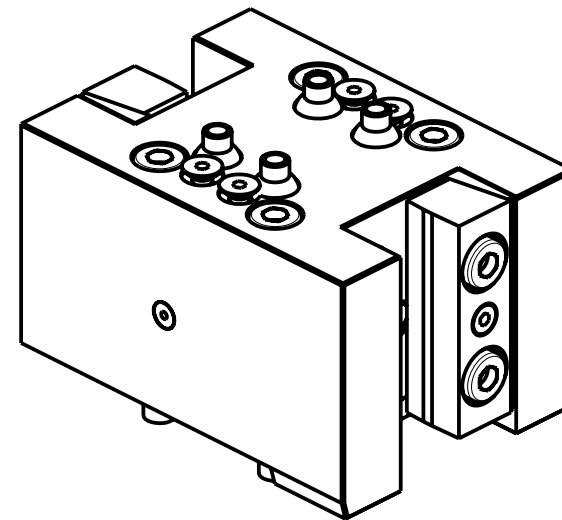
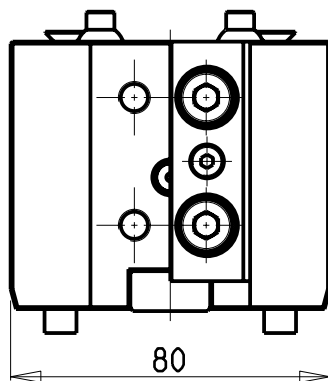
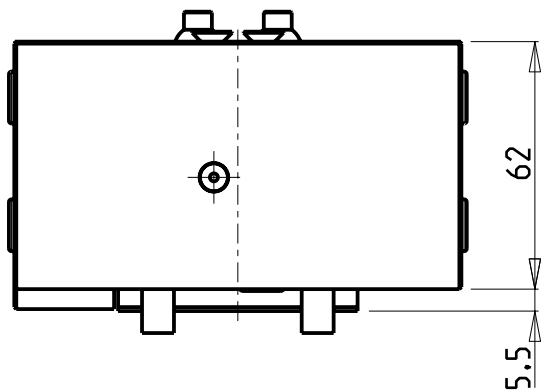

Cod. MT	N°Utensili N°Tools N°Werkzeuge	Reversibile lato mandrino/contromandrino Reversible sub/main spindle side Umkehrbare Spindel-seite/ Gegenspindel-seite	Misure Dimensions Masse	B	H
NKM0152010	2	x	mm	20	20

NAKAMURA-TOME

MOD: WT100 - WY100 - NTY3 - NTJ100 - SUPER NTMX

PORTAUTENSILE RADIALE DOPPIO

Radial double static tool

Radial Doppel-Werkzeughalter

M.T. srl

Via Casino Albini 480
Tel. 0541/956034-957884
Fax 0541/956341
47842 S. GIOVANNI IN M. (RN)
e-mail: mtma@mtmarchetti.com
http://www.mtmarchetti.com

PRODUZIONE MODULI ROTANTI



PAGINA NKM450-1-00

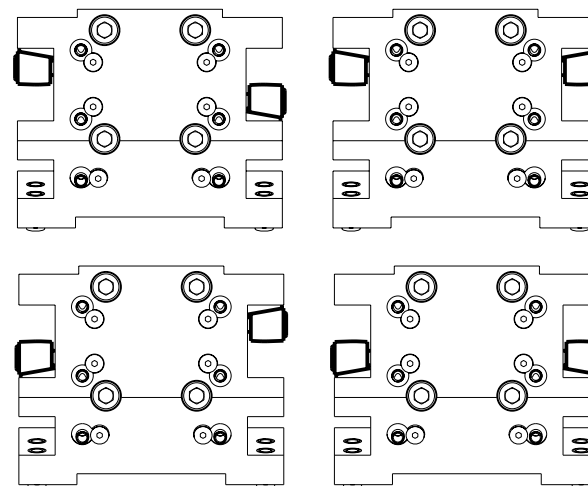
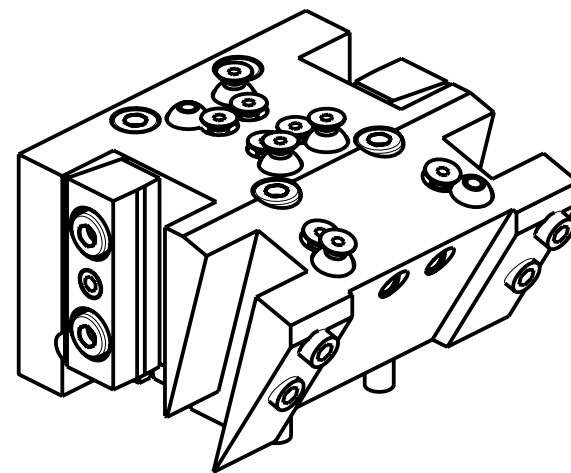
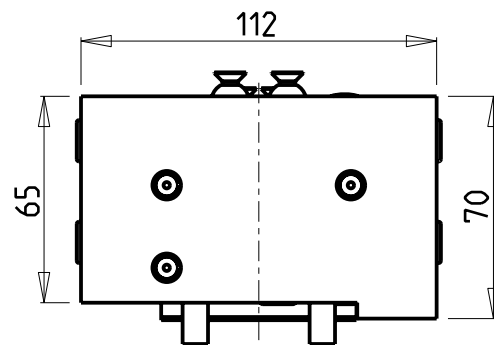
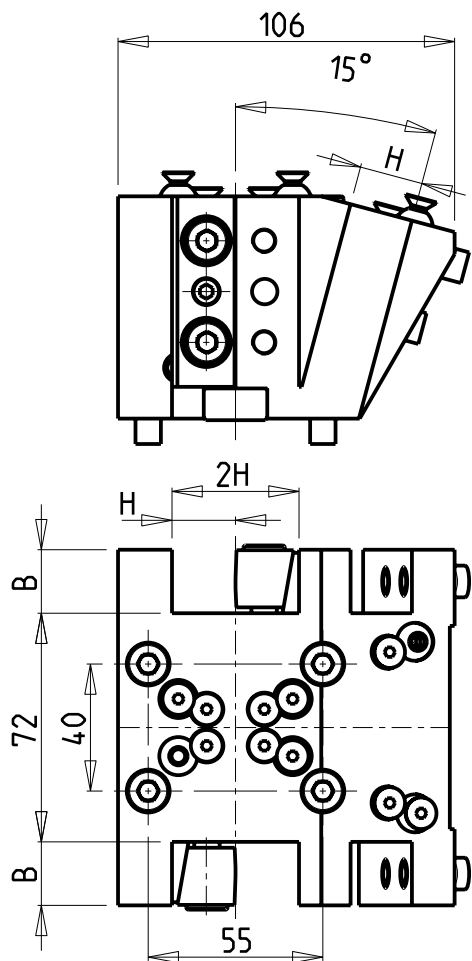

Cod. MT	N°Utensili N°Tools N°Werkzeuge	Reversibile lato mandrino/contromandrino Reversible sub/main spindle side Umkehrbare Spindel-seite/ Gegenspindel-seite	Misure Dimensions Masse	B	H
NKM0452000	4	X	mm	20	20

NAKAMURA-TOME
 MOD: WT100 - WY100 - NTY3 - NTJ100

PORTAUTENSILE RADIALE MULTIPLO
 Radial multiple static tool
 Radial Mehrfach-Halter

M.T. srl

Via Casino Albini 480
 Tel. 0541/956034-957884
 Fax 0541/956341
 47842 S. GIOVANNI IN M. (RN)
 e-mail: mtma@mtmarchetti.com
 http://www.mtmarchetti.com

PRODUZIONE MODULI ROTANTI



PAGINA NKM470-1-00

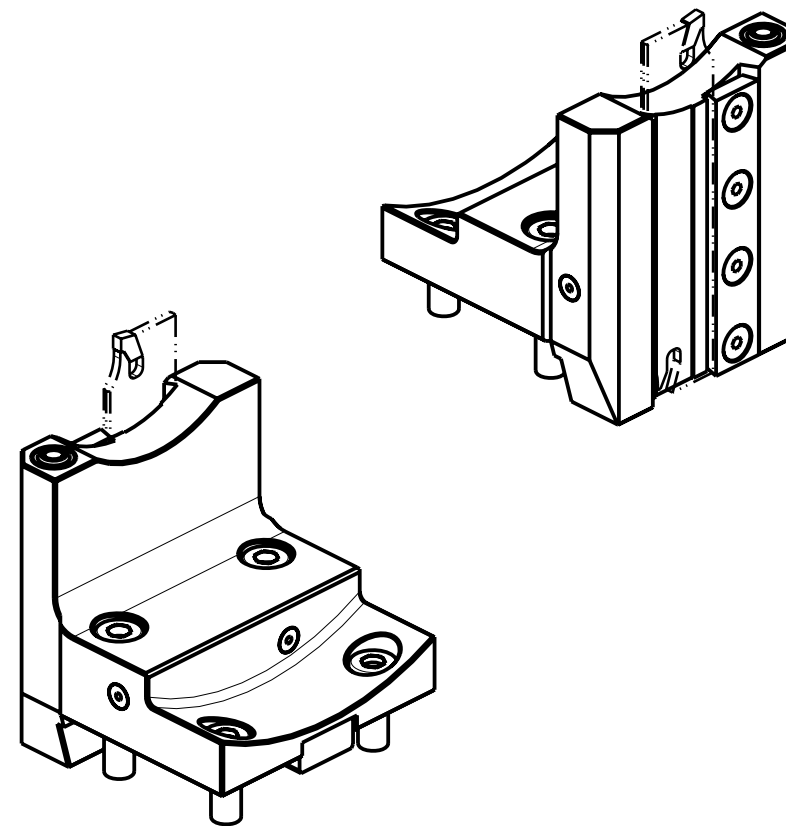
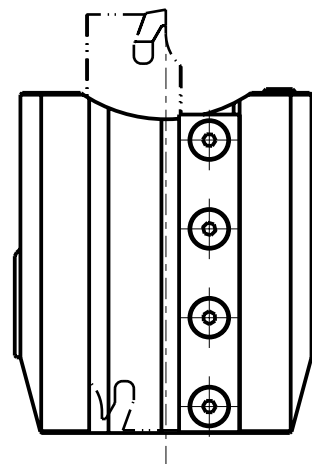
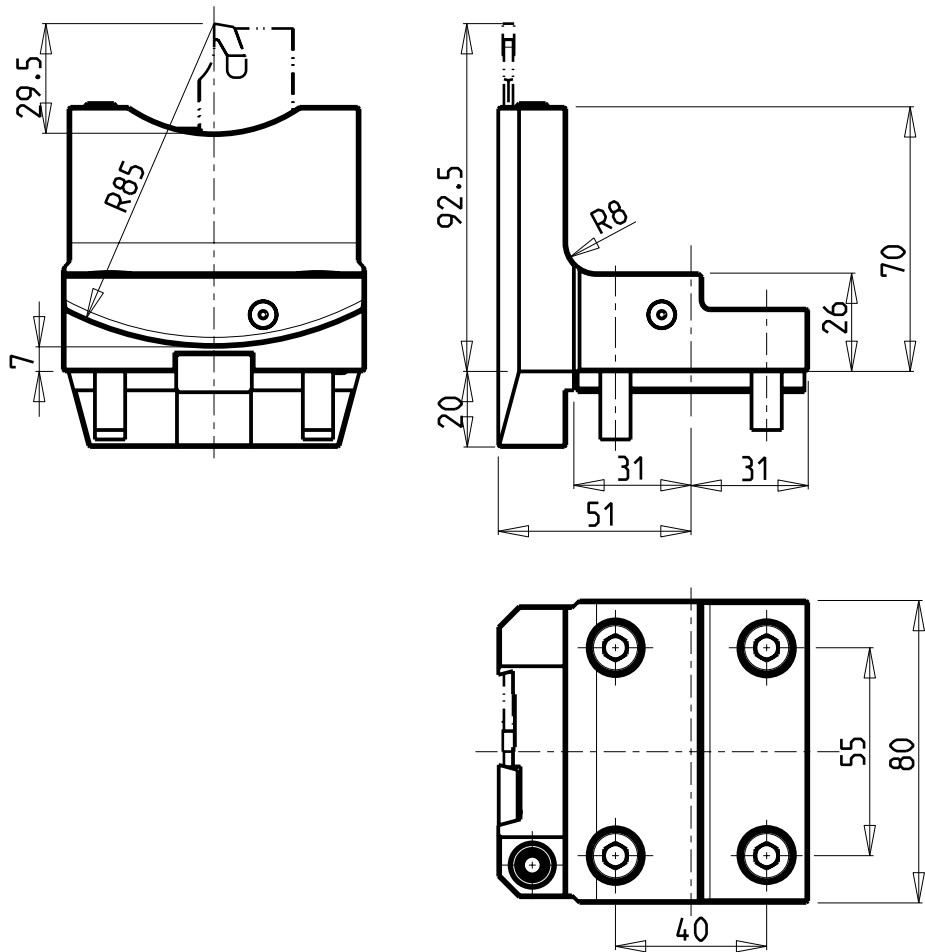

DOTAZIONI - SUPPLIED WITH - AUSSTATTUNG

- N°1 - LAMA - BLADE - KLINGE KENNAMETAL H=26 Sp. 3/4mm
- N°10 - INSERTI - INSERTS - EINLAGEN
- N°1 - CHIAVE A T PER MONTAGGIO INSERTI
 - T-WRENCH FOR INSERT SET UP
 - T-SCHLUESSEL FUER EINSATZSTUECK-MONTAGE

Cod. MT	N°Utensili N°Tools N°Werkzeuge
NKM0170126	1

NAKAMURA-TOME
 MOD: WT100 - WY100 - NTJ100
 PORTAUTENSILE RADIALE PER LAMA
 Radial blade holder
 Radial Abstechhalter

M.T. srl
 Via Casino Albini 480
 Tel. 0541/956034-957884
 Fax 0541/956341
 47842 S. GIOVANNI IN M. (RN)
 e-mail: mtma@mtmarchetti.com
 http://www.mtmarchetti.com

PRODUZIONE MODULI ROTANTI



PAGINA NKM513-1-00

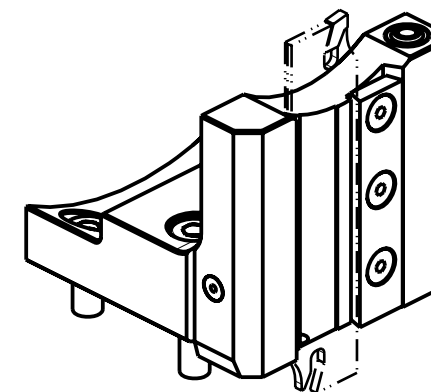
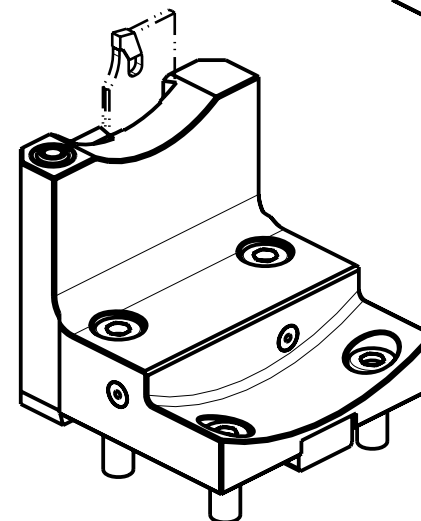
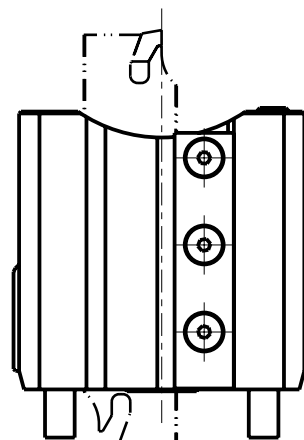
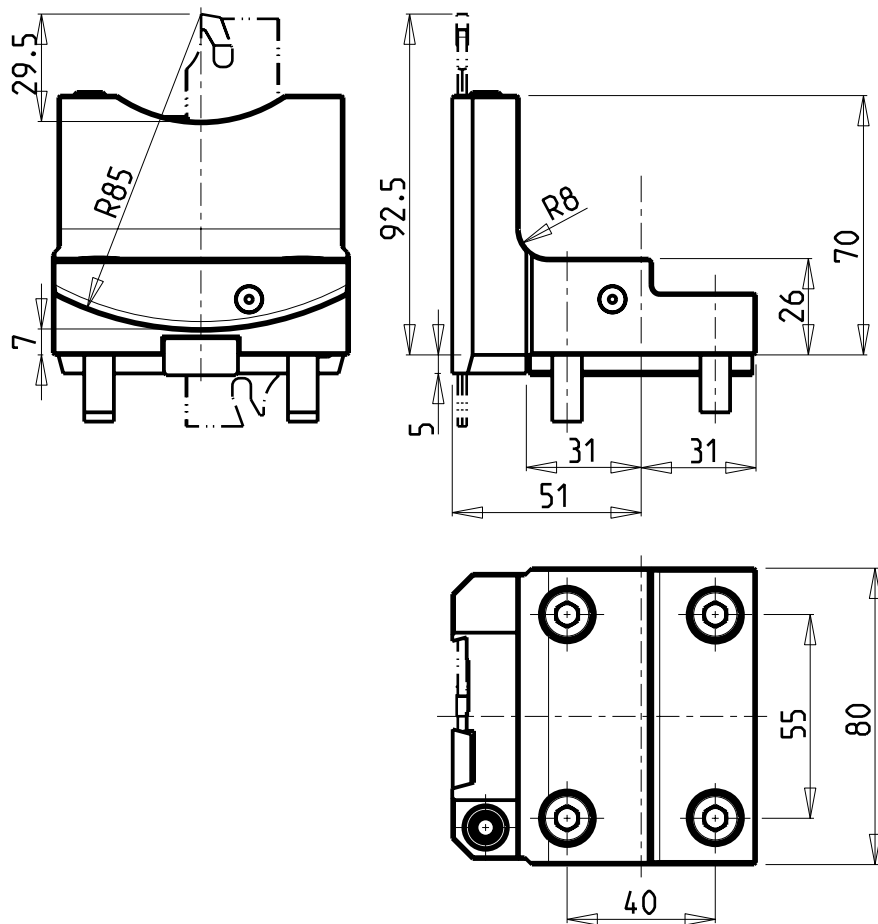

DOTAZIONI - SUPPLIED WITH - AUSSTATTUNG

- N°1 - LAMA - BLADE - KLINGE KENNAMETAL H=26 Sp. 3/4mm
- N°10 - INSERTI - INSERTS - EINLAGEN
- N°1 - CHIAVE A T PER MONTAGGIO INSERTI
 - T-WRENCH FOR INSERT SET UP
 - T-SCHLUESSEL FUER EINSATZSTUECK-MONTAGE

Cod. MT

N°Utensili
 N°Tools
 N°Werkzeuge

NKM0170226

1

NAKAMURA-TOME

MOD: WT100 - WY100 - NTY3 - NTJ100 - SUPER NTMX

PORTAUTENSILE RADIALE PER LAMA

Radial blade holder

Radial Abstechhalter

M.T. srl

Via Casino Albini 480
 Tel. 0541/956034-957884
 Fax 0541/956341
 47842 S. GIOVANNI IN M. (RN)
 e-mail: mtma@mtmarchetti.com
 http://www.mtmarchetti.com

PRODUZIONE MODULI ROTANTI



PAGINA NKM513-1-10

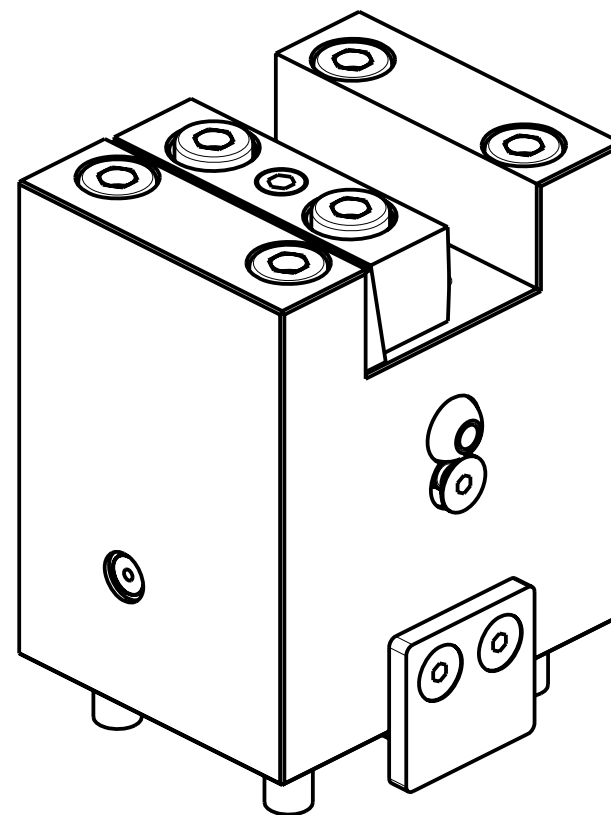
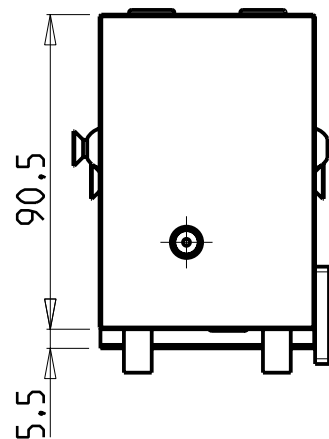
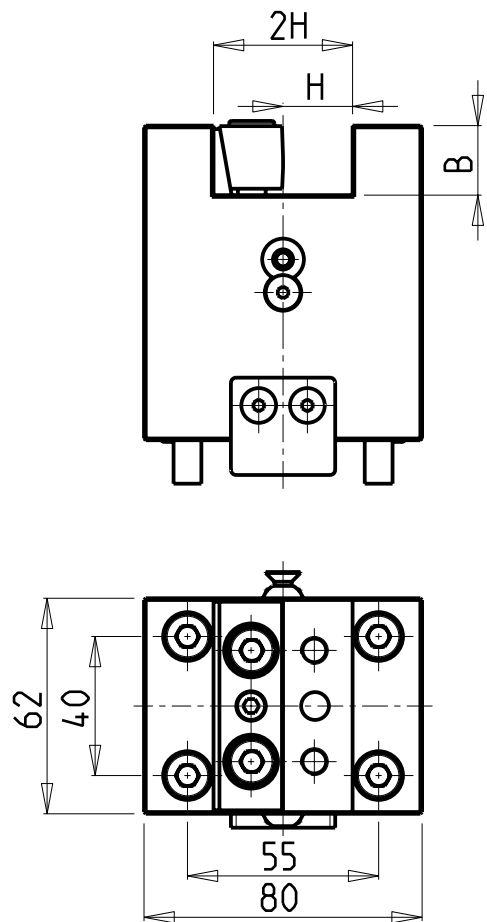

Cod. MT	N°Utensili N°Tools N°Werkzeuge	Reversibile lato mandrino/contromandrino Reversible sub/main spindle side Umkehrbare Spindel-seite/ Gegenspindel-seite	Misure Dimensions Masse	B	H
NKM0182010	1	X	mm	20	20

NAKAMURA-TOME

MOD: WT100 - WY100 - NTY3 - NTJ100 - SUPER NTMX

PORTAUTENSILE ASSIALE SINGOLO

Axial single static tool

Axial Single-Werkzeughalter

M.T. srl

Via Casino Albini 480
Tel. 0541/956034-957884
Fax 0541/956341
47842 S. GIOVANNI IN M. (RN)
e-mail: mtma@mtmarchetti.com
<http://www.mtmarchetti.com>

PRODUZIONE MODULI ROTANTI



PAGINA NKM550-1-00

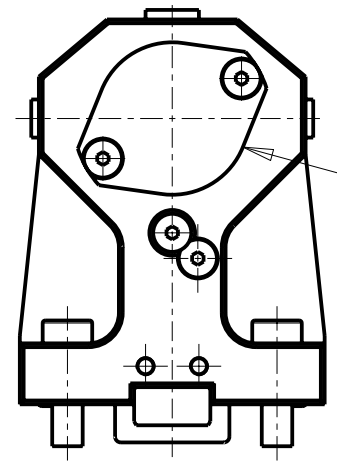
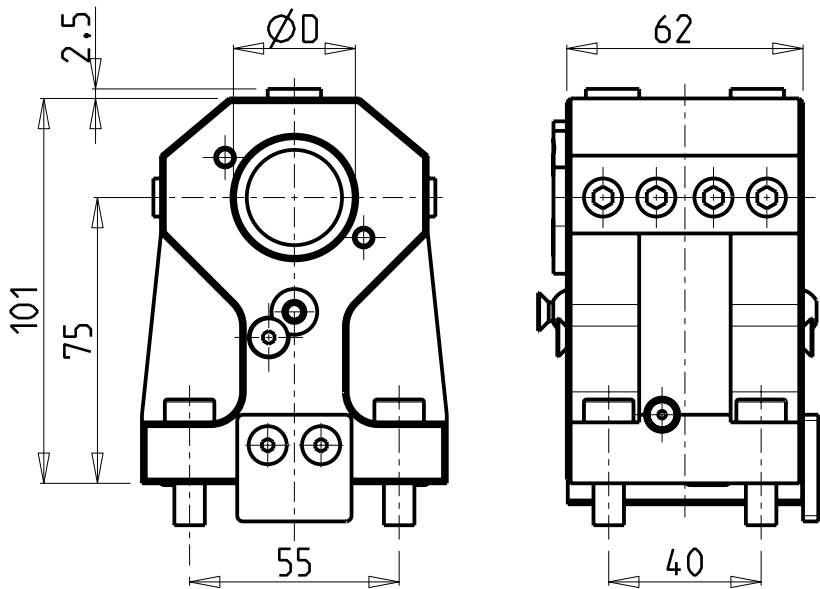

KIT ADDUZIONE INTERNA (OPZIONALE)
 KIT FOR INTERNAL COOLANT (OPTIONAL)
 KIT FUER INTERNE KUEHLMITTELZUFUHR (OPTIONAL)
 Ø32 cod. KIT1000001

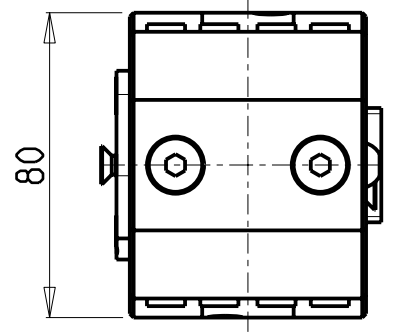

PER BOCCOLE DI RIDUZIONE VEDI PAG. TBL150-1-00
 FOR REDUCING BUSHINGS SEE PAGE TBL150-1-00
 FÜR REDUZIERBUCHSE SIEHE SEITE TBL150-1-00

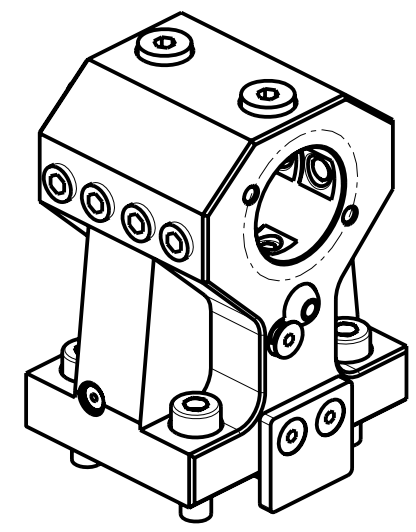

Cod. MT	N°Utensili N°Tools N°Werkzeuge	Reversibile lato mandrino/contromandrino Reversible sub/main spindle side Umkehrbare Spindel-seite/ Gegenspindel-seite	Lubrificazione int. opzionale Coolant through optional Innenkuehlung Optional	Lubrificazione est. Ext. coolant Aussehenkuehlung	Misure Dimensions Masse	D
NKM0733200	1	X	X	X	mm	32

NAKAMURA-TOME
 MOD: SUPER NTMX

PORTAUTENSILE ASSIALE PER BARENO Ø32mm H=75mm
 Axial single boring bar holder Ø32mm H=75mm
 Axial Bohrhälter Ø32mm H=75mm



M.T. srl
 Via Casino Albini 480
 Tel. 0541/956034-957884
 Fax 0541/956341
 47842 S. GIOVANNI IN M. (RN)
 e-mail: mtma@mtmarchetti.com
 http://www.mtmarchetti.com

PRODUZIONE MODULI ROTANTI

PAGINA NKM650-1-10

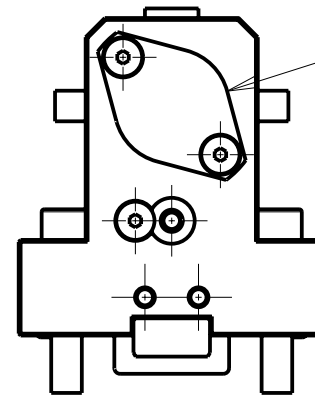
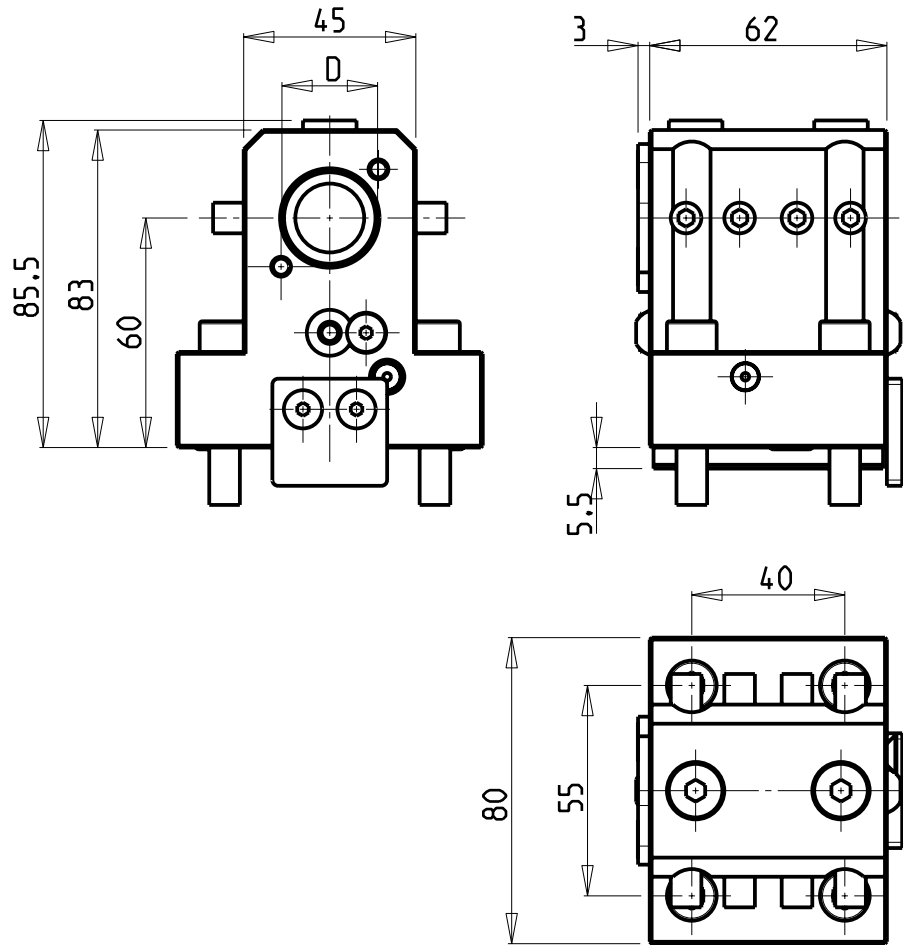

KIT ADDUZIONE INTERNA (OPZIONALE)
 KIT FOR INTERNAL COOLANT (OPTIONAL)
 KIT FUER INTERNE KUEHLMITTELZUFUHR (OPTIONAL)
 Ø25-Ø1" cod. KIT1000006

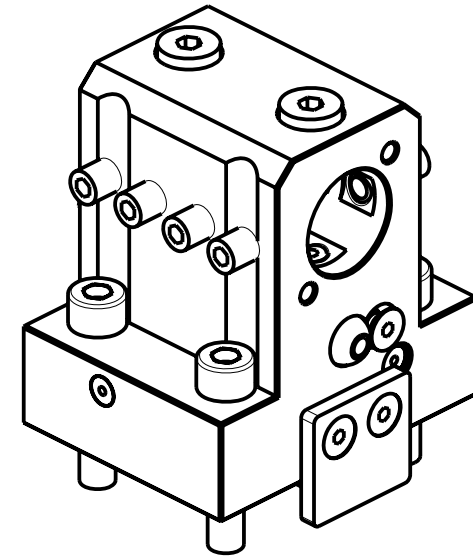

Cod. MT	N°Utensili N°Tools N°Werkzeuge	Reversibile lato mandrino/contromandrino Reversible sub/main spindle side Umkehrbare Spindel-seite/ Gegenspindel-seite	Lubrificazione int. opzionale Coolant through optional Innenkuehlung Optional	Lubrificazione est. Ext. coolant Aussenkuehlung	Misure Dimensions Masse	D
NKM0112540	1	X	X	X	mm	25

NAKAMURA-TOME
 MOD: WT100 - WY100 - NTY3 - NTJ100
 PORTAUTENSILE ASSIALE PER BARENO Ø25mm H=60mm
 Axial single boring bar holder Ø25mm H=60mm
 Axial Bohrhalter Ø25mm H=60mm

M.T. srl
 Via Casino Albini 480
 Tel. 0541/956034-957884
 Fax 0541/956341
 47842 S. GIOVANNI IN M. (RN)
 e-mail: mtma@mtmarchetti.com
 http://www.mtmarchetti.com

PRODUZIONE MODULI ROTANTI



PAGINA NKM670-1-10

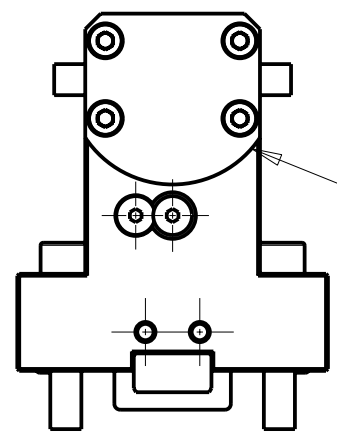
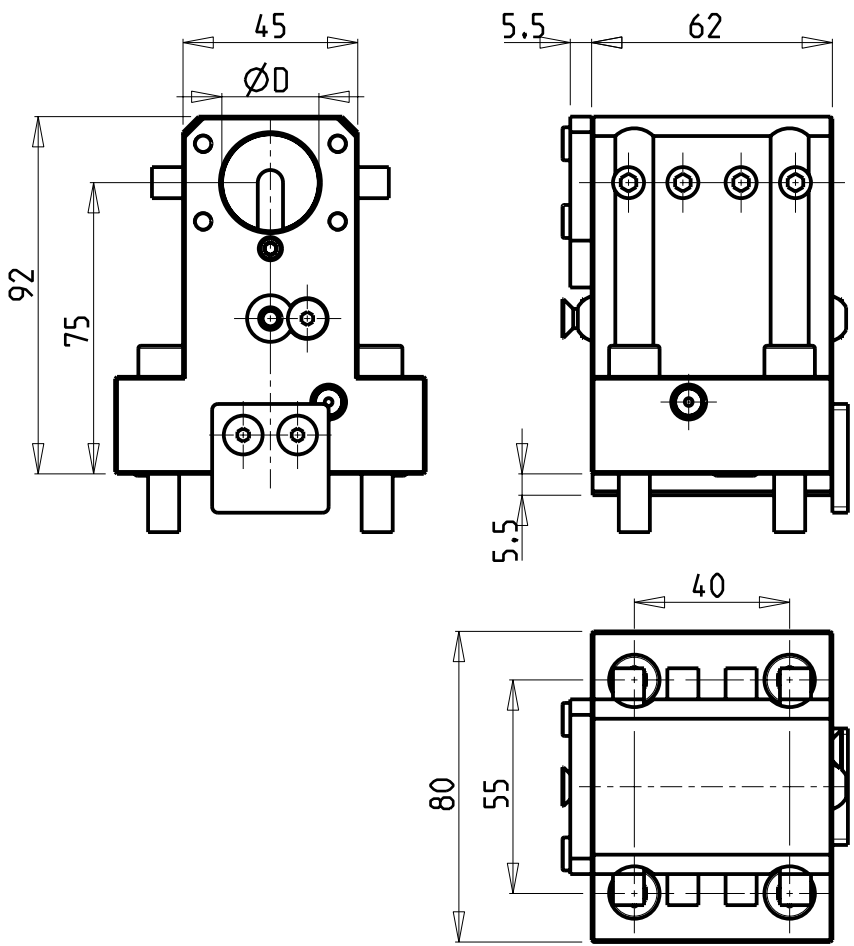

KIT ADDUZIONE INTERNA (OPZIONALE)
 KIT FOR INTERNAL COOLANT (OPTIONAL)
 KIT FUER INTERNE KUEHLMITTELZUFUHR (OPTIONAL)
 Ø25-Ø1" cod. KIT1000017

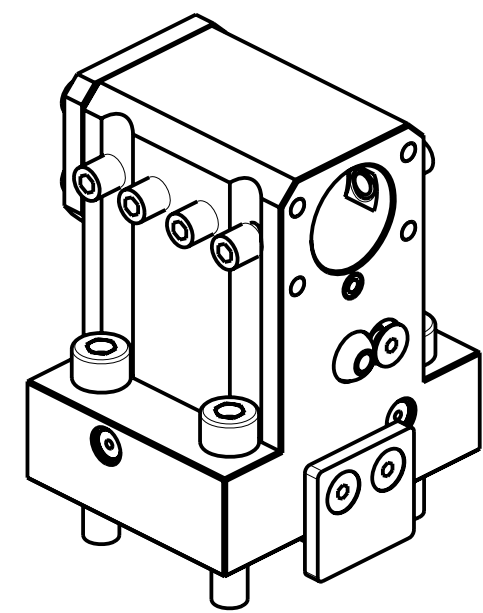

Cod. MT	N°Utensili N°Tools N°Werkzeuge	Reversibile lato mandrino/contromandrino Reversible sub/main spindle side Umkehrbare Spindel-seite/ Gegenspindel-seite	Lubrificazione int. opzionale Coolant through optional Innenkuehlung Optional	Lubrificazione est. Ext. coolant Aussenkuehlung	Misure Dimensions Masse	D
NKM0112560	1	X	X	X	mm	25

NAKAMURA-TOME
 MOD: WT100 - WY100 - NTY3 - NTJ100
 PORTAUTENSILE ASSIALE PER BARENO Ø25mm H=75mm
 Axial single boring bar holder Ø25mm H=75mm
 Axial Bohrhalter Ø25mm H=75mm



M.T. srl
 Via Casino Albini 480
 Tel. 0541/956034-957884
 Fax 0541/956341
 47842 S. GIOVANNI IN M. (RN)
 e-mail: mtma@mtmarchetti.com
 http://www.mtmarchetti.com

PRODUZIONE MODULI ROTANTI

PAGINA NKM670-1-20

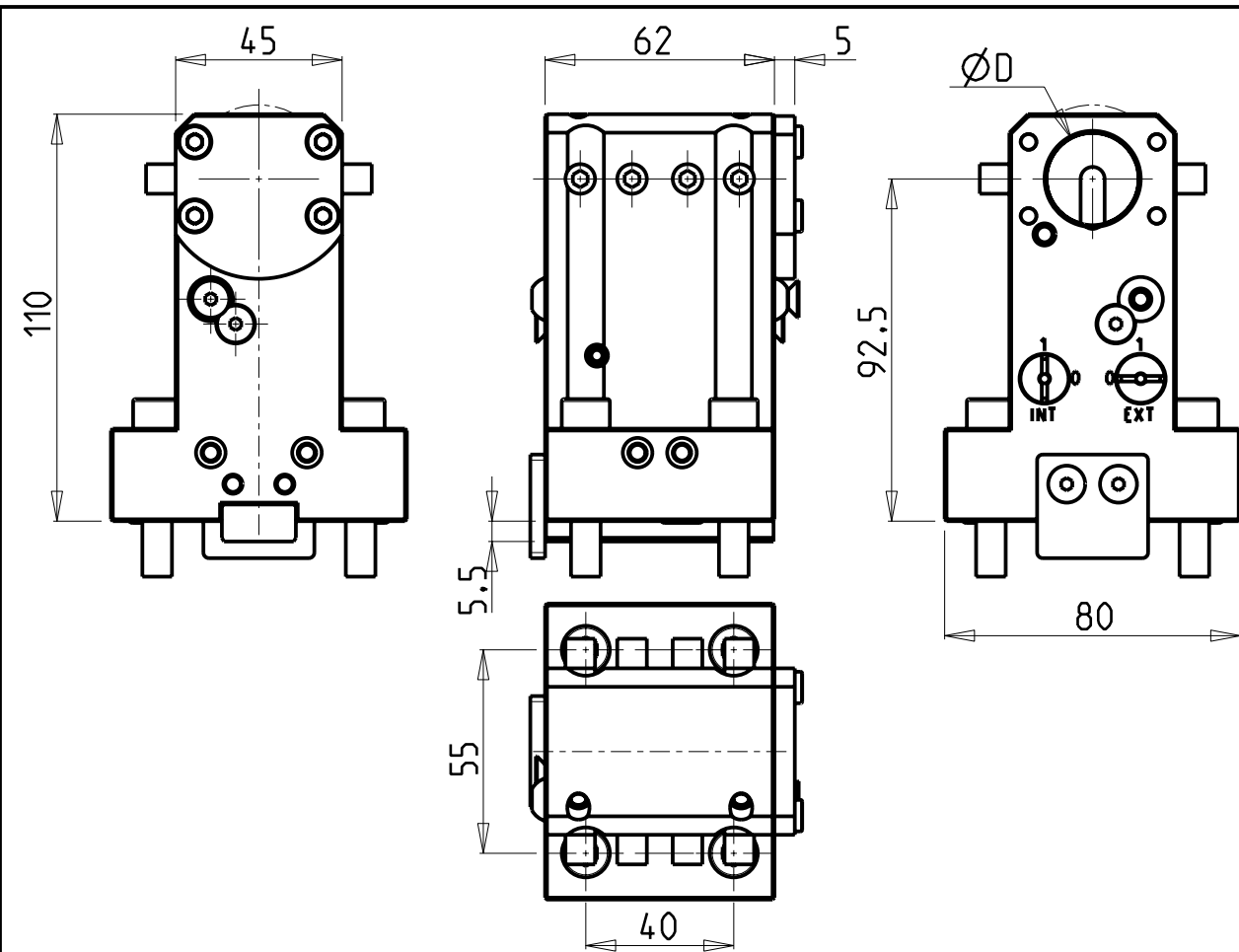

KIT ADDUZIONE INTERNA (OPZIONALE)
 KIT FOR INTERNAL COOLANT (OPTIONAL)
 KIT FUER INTERNE KUEHLMITTELZUFUHR (OPTIONAL)
 Ø25-Ø1" cod. KIT1000017

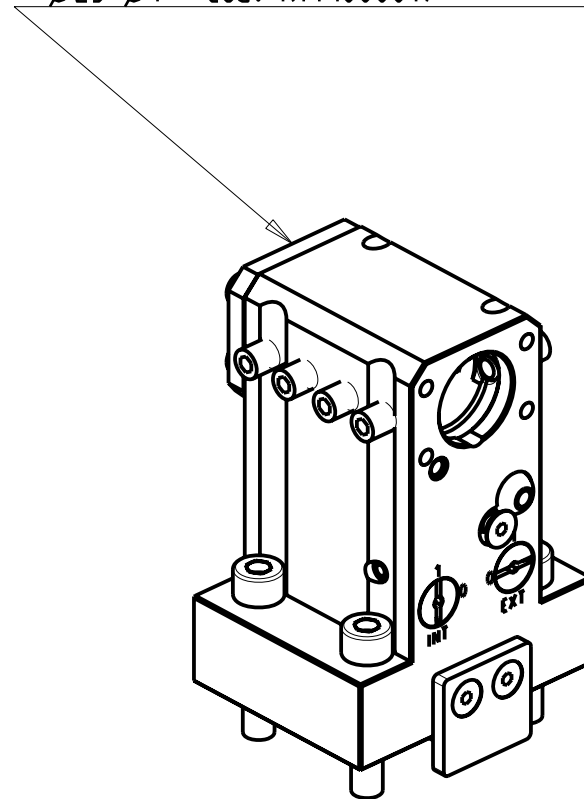

Cod. MT	N°Utensili N°Tools N°Werkzeuge	Reversibile lato mandrino/Contromandrino Reversible sub/main spindle side Umkehrbare Spindel-seite/ Gegenspindel-seite	Lubrificazione int. opzionale Coolant through optional Innenkuehlung Optional	Lubrificazione est. Ext. coolant Aussenkuehlung	Misure Dimensions Masse	D
NKM0722500	1	X	X	X	mm	25
NKM0722540	1	X	X	X	Inch	1"

NAKAMURA-TOME
 MOD: SUPER NTMX

PORTAUTENSILE ASSIALE PER BARENO Ø25mm / Ø1" H=92.5mm
 Axial single boring bar holder Ø25mm / Ø1" H=92.5mm
 Axial Bohrhälter Ø25mm / Ø1" H=92.5mm

M.T. srl

Via Casino Albini 480
 Tel. 0541/956034-957884
 Fax 0541/956341
 47842 S. GIOVANNI IN M. (RN)
 e-mail: mtma@mtmarchetti.com
 http://www.mtmarchetti.com

PRODUZIONE MODULI ROTANTI



PAGINA NKM685-1-10

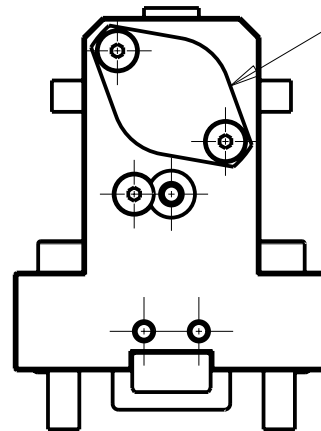
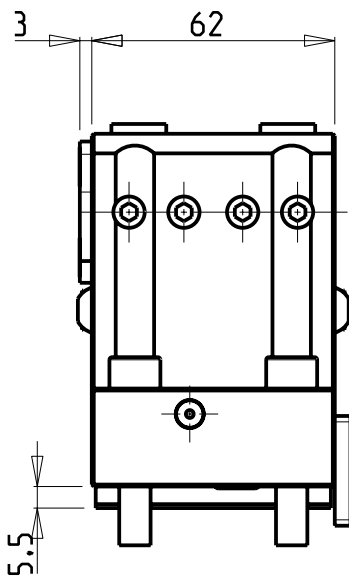
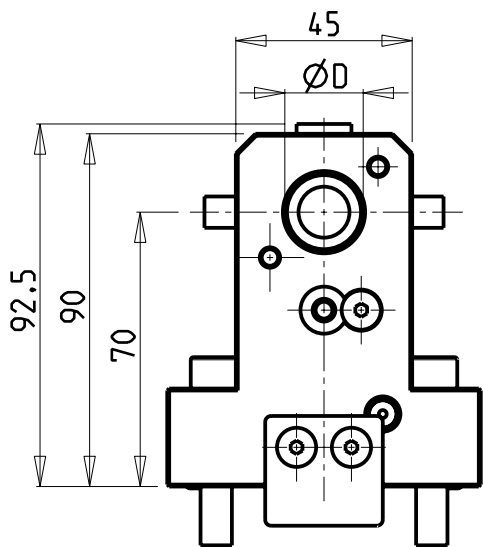

KIT ADDUZIONE INTERNA (OPZIONALE)
 KIT FOR INTERNAL COOLANT (OPTIONAL)
 KIT FUER INTERNE KUEHLMITTELZUFUHR (OPTIONAL)
 cod. KIT1000015

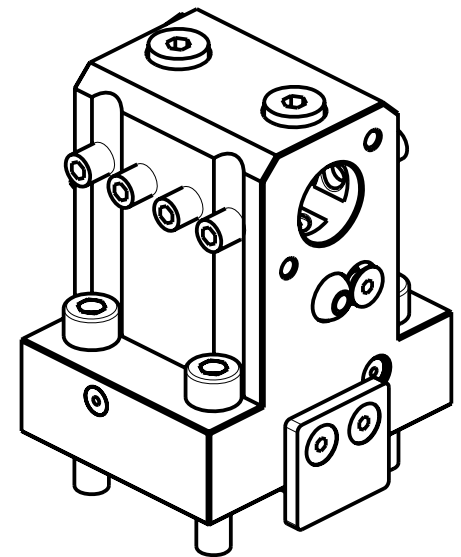
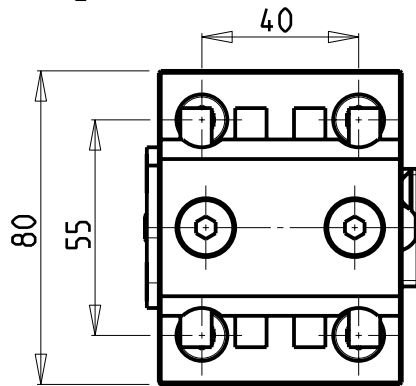

Cod. MT	N°Utensili N°Tools N°Werkzeuge	Reversibile lato mandrino/contromandrino Reversible sub/main spindle side Umkehrbare Spindel-seite/ Gegenspindel-seite	Lubrificazione int. opzionale Coolant through optional Innenkuehlung Optional	Lubrificazione est. Ext. coolant Aussenkuehlung	Misure Dimensions Masse	Ø
NKM0112550	1	X	X	X	mm	20

NAKAMURA-TOME
 MOD: WT100 - WY100 - NTY3 - NTJ100
 PORTAUTENSILE ASSIALE PER BARENO Ø20mm H=70mm
 Axial single boring bar holder Ø20mm H=70mm
 Axial Bohrhalter Ø20mm H=70mm

M.T. srl
 Via Casino Albini 480
 Tel. 0541/956034-957884
 Fax 0541/956341
 47842 S. GIOVANNI IN M. (RN)
 e-mail: mtma@mtmarchetti.com
 http://www.mtmarchetti.com

PRODUZIONE MODULI ROTANTI



PAGINA NKM690-1-10

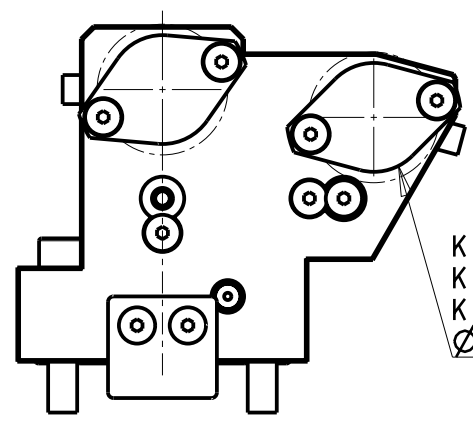
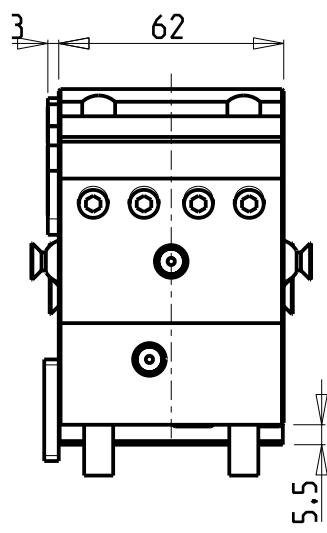
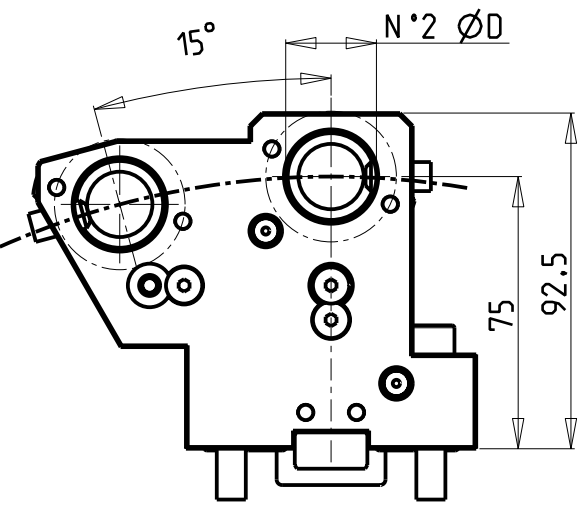

KIT ADDUZIONE INTERNA (OPZIONALE)
 KIT FOR INTERNAL COOLANT (OPTIONAL)
 KIT FÜR INTERNE KUEHLMITTELZUFUHR (OPTIONAL)
 Ø25-Ø1" cod. KIT1000006

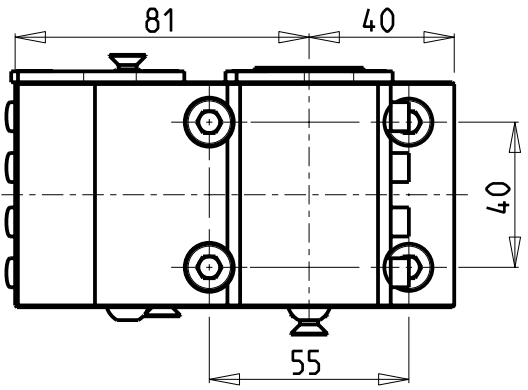

PER BOCCOLE DI RIDUZIONE VEDI PAG. TBL150-1-00
 FOR REDUCING BUSHINGS SEE PAGE TBL150-1-00
 FÜR REDUZIERBUCHSE SIEHE SEITE TBL150-1-00

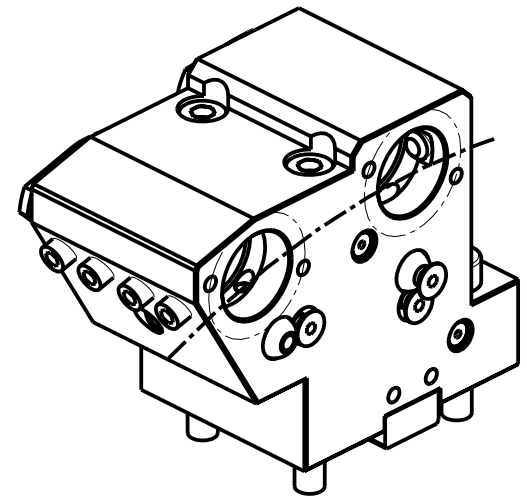

Cod. MT	Cod. NAKAMURA	N°Utensili N°Tools N°Werkzeuge	Reversibile lato mandrino/contromandrino Reversible sub/main spindle side Umkehrbare Spindel-seite/ Gegenspindel-seite	Lubrificazione int. opzionale Coolant through optional Innenkuehlung Optional	Lubrificazione est. Ext. coolant Aussenkuehlung	Misure Dimensions Masse	D
NKM0462500	C22413	2	X	X	X	mm	25

NAKAMURA-TOME
 MOD. WT100 - WY100 - NTY3 - NTJ100
 PORTAUTENSILE ASSIALE PER BARENO 2 POSIZIONI Ø25mm
 Axial 2 position upright boring bar holder Ø25mm
 Axial Bohrhalter 2 Positionen Ø25mm



M.T. srl
 Via Casino Albini 480
 Tel. 0541/956034-957884
 Fax 0541/956341
 47842 S. GIOVANNI IN M. (RN)
 e-mail: mtma@mtmarchetti.com
 http://www.mtmarchetti.com

PRODUZIONE MODULI ROTANTI



PAGINA NKM864-1-50

ATTENZIONE - ATTENTION - ACHTUNG

- FINO AD ESAURIMENTO SCORTE
- clearance sale
- solange vorrat

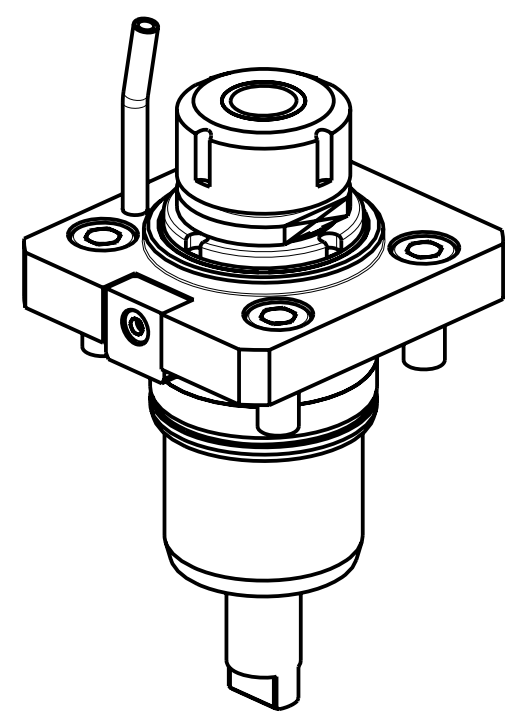
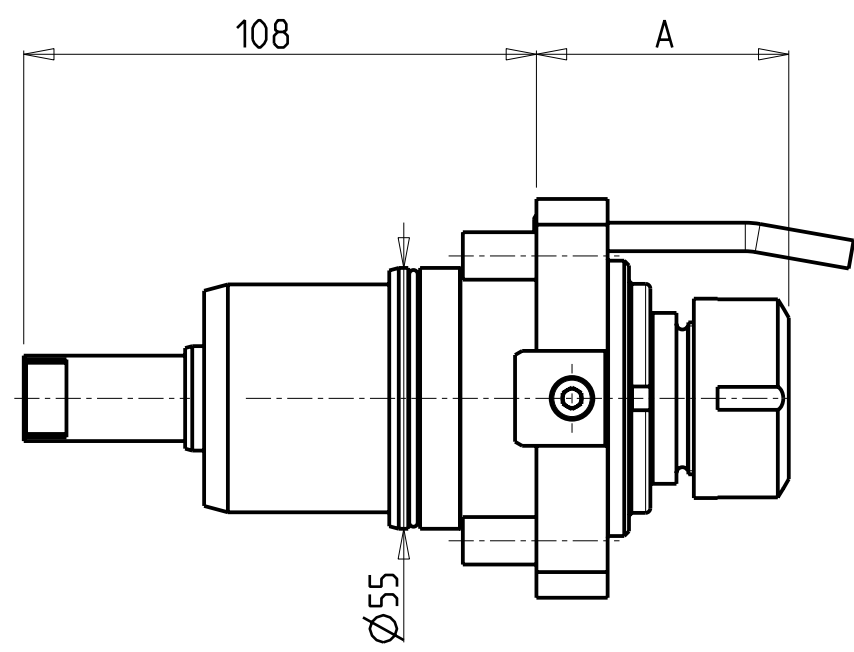
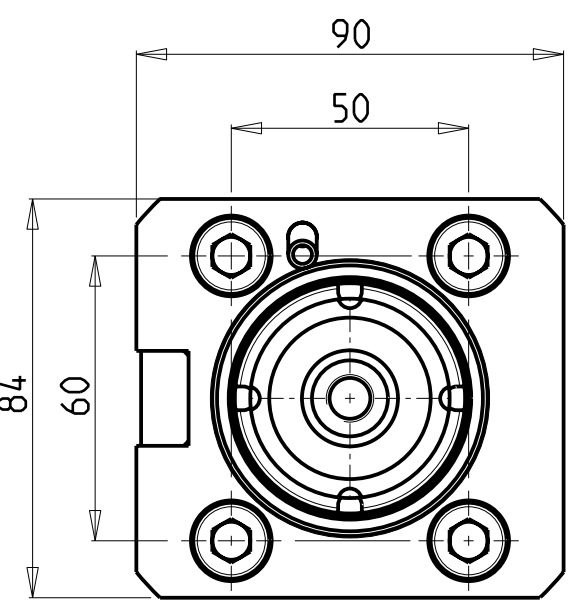

Cod. MT	Mandrino Spindle Spindel	I	RPM	Coppia Max Max Torque Max Drehmoment	Lubrificazione int. Coolant through Innenkuhlung	Lubrificazione est. Ext. coolant Aussenkuhlung	A	CHIAVI NON INCLUSE Keys not included Schlüssel nicht einbegriffen	
NKM0011020	ER20	1:1	6000	50Nm	P=30bar	X	70.66	CHUB36	CHSTER20
NKM0011025	ER25	1:1	6000	50Nm	P=30bar	X	71.66	CHUB29	CHSTER25

NAKAMURA-TOME
 WT150/250 - WT15011/25011 - WTW150 - WTS150 - SUPER NTM3 - SUPER NTJ - SUPER NTJX - SC200/250
 NTY3_250 - TW10M/MY/MM/MMY/MMYY-TW20M/MY/MM/MMY/MMYY 16 ST.

MODULO MOTORIZZATO RADIALE
 Radial driven tool
 Radial angetriebenes Werkzeug

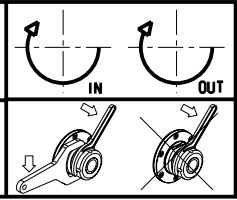

M.T. srl
 Via Casino Albini 480
 Tel. 0541/956034-957884
 Fax 0541/956341
 47842 S. GIOVANNI IN M. (RN)
 e-mail: mtma@mtmarchetti.com
 http://www.mtmarchetti.com

PRODUZIONE MODULI ROTANTI

PAGINA NKM010-2-00

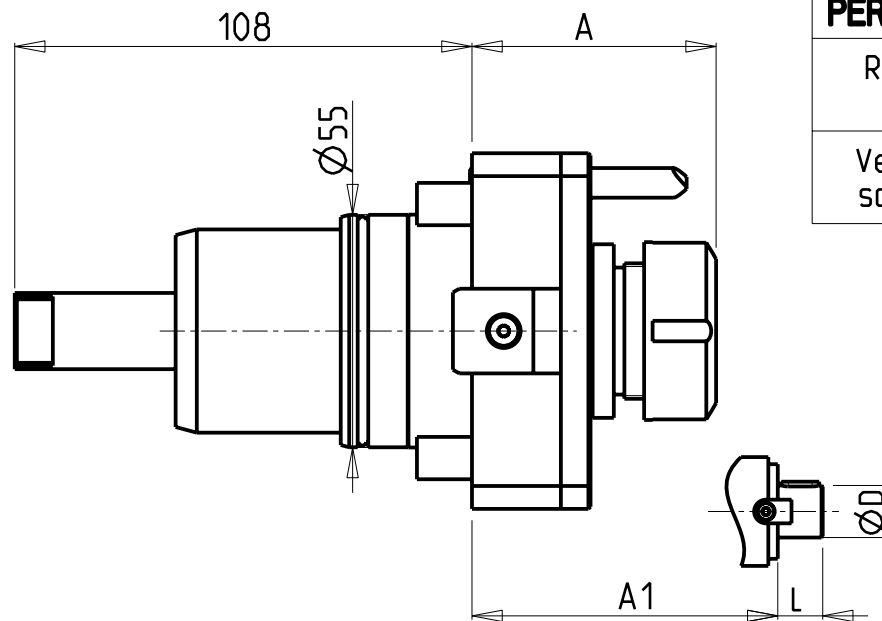
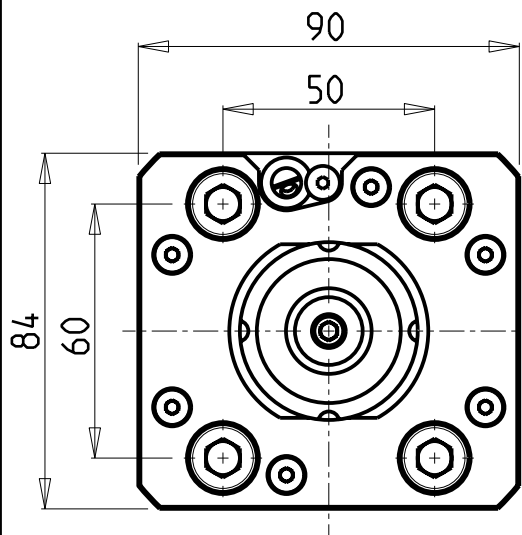

CUSCINETTI MAGGIORATI PER LAVORAZIONI PESANTI

Reinforced bearings for
heavy machining

Vergroesserte Lager fuer
schwerere Bearbeitungen

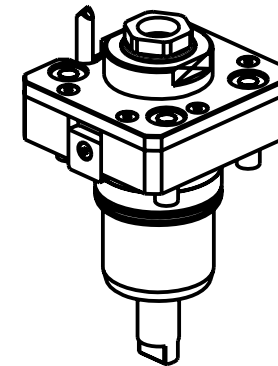

NKM0700325

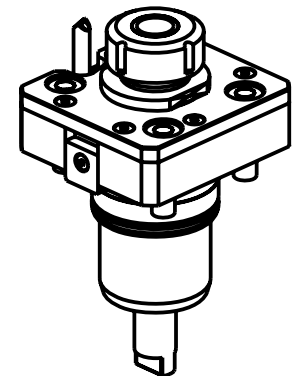
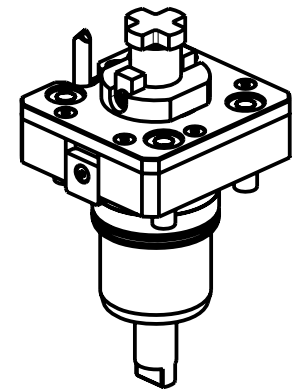

Cod. MT	Mandrino Spindle Spindel	I	RPM	Coppia Max Max Torque Max Drehmoment	Lubrificazione int. Coolant through Innenkuhlung	Lubrificazione est. Ext. coolant Aussenkuhlung	A	A1	D	L	CHIAVI NON INCLUSE Keys not included Schluessel nicht einbegriffen	
NKM0700325	ER A 25	1:1	6000	50Nm		X	51	-	-	-	CHUB41	CHUB27
NKM0700125	ER25	1:1	6000	50Nm		X	57.16	-	-	-	CHUB41	CHSTER25
NKM0700225	ER25	1:1	6000	50Nm	P=30bar	X	68.16	-	-	-	CHUB41	CHSTER25
NKM0700132	ER32	1:1	6000	50Nm		X	61.66	-	-	-	CHUB41	CHSTER32
NKM0700232	ER32	1:1	6000	50Nm	P=30bar	X	73.16	-	-	-	CHUB41	CHSTER32
NKM0702219	Ø22x19	1:1	6000	50Nm		X	-	39	22	19	CHUB41	CH_VTCROCE_M10
NKM0702519	Ø1" x19	1:1	6000	50Nm		X	-	42	1"	21	CHUB41	CH_VTCROCE_M12

- Chiave inclusa
- Key included
- Schluessel inbegriffen

NAKAMURA-TOME

WT150/250 - WT15011/25011 - WTW150 - WTS150 - SUPER NTM3 - SUPER NTJ - SUPER NTJX - SC200/250
NTY3_250 - TW10M/MY/MM/MMY/MMYY-TW20M/MY/MM/MMY/MMYY 16 ST.

MODULO MOTORIZZATO RADIALE

Radial driven tool

Radial angetriebenes Werkzeug

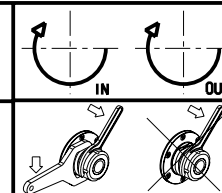

M.T. srl

Via Casino Albini 480
Tel. 0541/956034-957884
Fax 0541/956341
47842 S. GIOVANNI IN M. (RN)
e-mail: mtma@mtmarchetti.com
http://www.mtmarchetti.com

PRODUZIONE MODULI ROTANTI



PAGINA NKM020-2-00

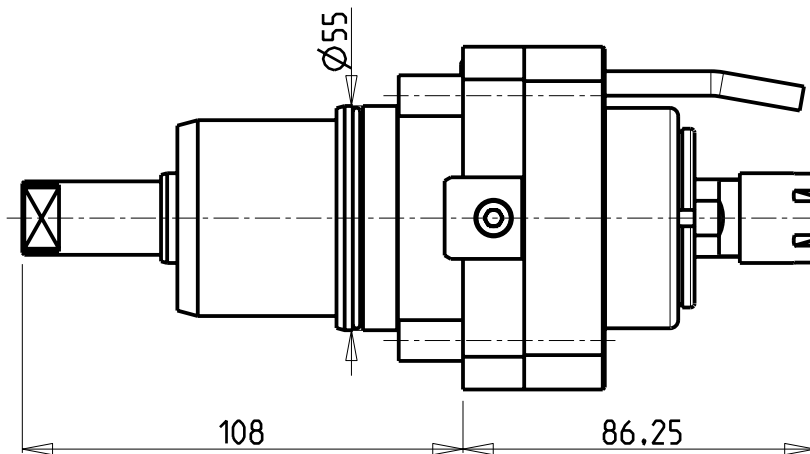
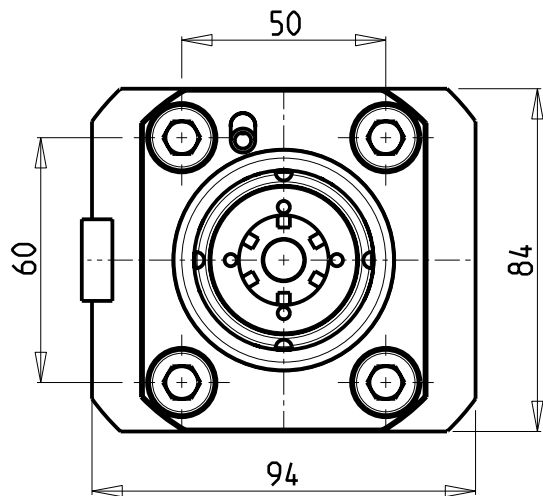

ATTENZIONE - ATTENTION - ACHTUNG

- Per lo smontaggio degli utensili utilizzare sempre la chiave di contrasto come indicato nel manuale d'uso.
- For disassembly of the tools use always the contrast key as mentioned in the user instructions.
- Fuer das Abmontieren der Werkzeuge immer den Gegenschlüssel benutzen wie in der Bedienungsanleitung erwäehnt.

ATTENZIONE - ATTENTION - ACHTUNG

- PRIMA DI UTILIZZARE IL MOTORIZZATO CONSULTARE LE ISTRUZIONI ALLEGATE!
- BEFORE USING THE DRIVEN TOOL, PLEASE CHECK THE ENCLOSED INSTRUCTION SHEET!
- VOR DER BENUTZUNG DES ANGETRIEBENEN WERKZEUGES, DIE BEILIEGENDEN INSTRUKTIONEN DURCHLESEN!

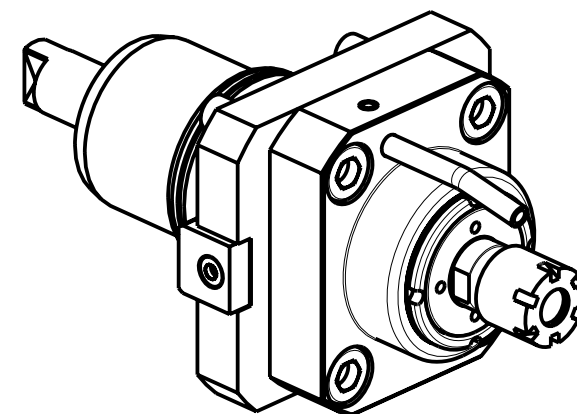

Cod. MT	Mandrino Spindle Spindel	I	RPM	Coppia Max Max Torque Max Drehmoment	Lubrificazione est. Ext. coolant Aussenkuehlung	CHIAVI INCLUSE Keys included Schluessel einbegriffen	
NKM0040016	ER16	1:3	18000	10Nm	X	CHUB17	CHMNER16

NAKAMURA-TOME

WT150/250 - WT15011/25011 - WTW150 - WTS150 - SUPER NTM3 - SUPER NTJ - SUPER NTJX - SC200/250
 NTY3 250 - TW10M/MY/MM/MYY/MYY-TW20M/MY/MM/MYY/MYY 16 ST.

MODULO MOTORIZZATO RADIALE MOLTIPLICATO I=1:3

Radial geared-up I=1:3 driven tool

Radial angetriebenes Werkzeug uebersetzt I=1:3

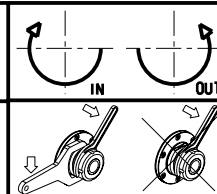

M.T. srl

Via Casino Albini 480
 Tel. 0541/956034-957884

Fax 0541/956341

47842 S. GIOVANNI IN M. (RN)

e-mail: mtma@mtmarchetti.com

http://www.mtmarchetti.com

PRODUZIONE MODULI ROTANTI



PAGINA NKM055-2-00

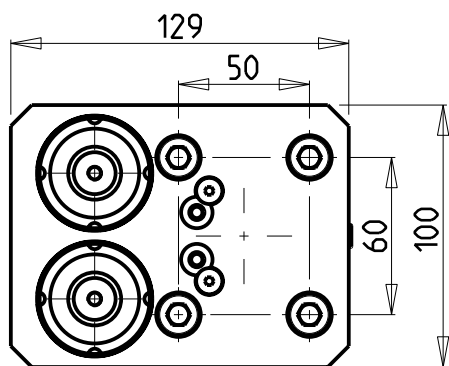
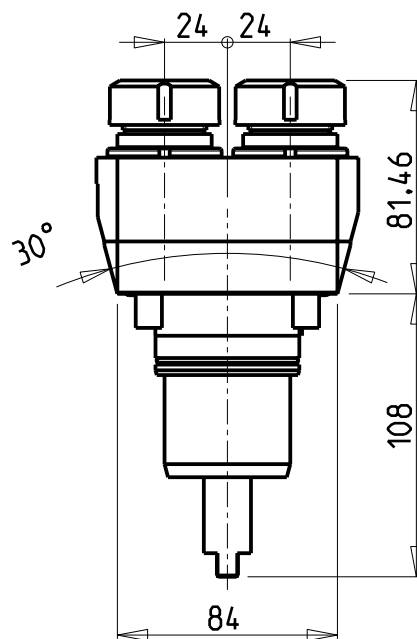
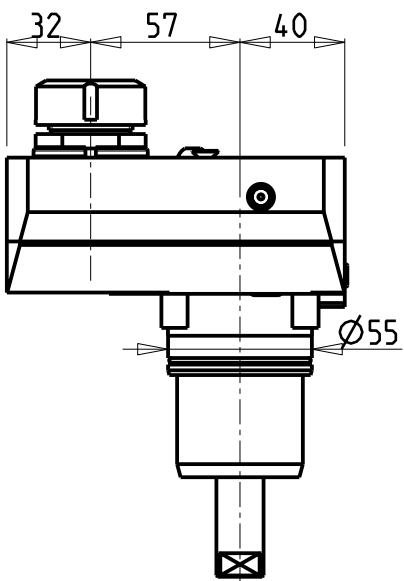

ATTENZIONE - ATTENTION - ACHTUNG

- Per lo smontaggio degli utensili utilizzare sempre la chiave di contrasto come indicato nel manuale d'uso.
- For disassembly of the tools use always the contrast key as mentioned in the user instructions.
- Fuer das Abmontieren der Werkzeuge immer den Gegenschlüssel benutzen wie in der Bedienungsanleitung erwäehnt.

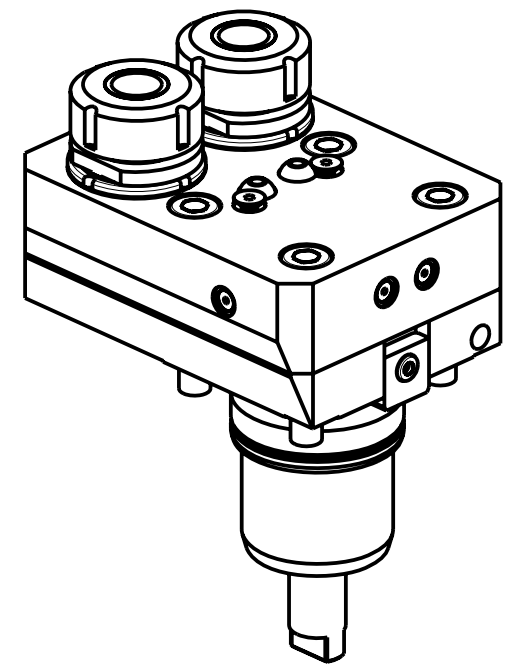

Cod. MT	Mandrino Spindle Spindel	I	RPM	Coppia Max Max Torque Max Drehmoment	Lubrificazione est. Ext. coolant Aussenkuehlung	Reversibile lato mandrino/contromandrino Reversible sub/main spindle side Umkehrbare Spindelsete/Gegenspindelsete	CHIAVI NON INCLUSE Keys not included Schluessel nicht inbegriffen	
NKM0320225	ER25	1:1	6000	30Nm	X	X	CHUB36	CHSTER25

NAKAMURA-TOME
 WT150/250 - WT15011/25011 - WTW150 - WTS150 - SUPER NTM3 - SUPER NTJ - SUPER NTJX - SC200/250
 NTY3 250 - TW10M/MY/MM/MMY/MMYY-TW20M/MY/MM/MMY/MMYY 16 ST.
 MODULO MOTORIZZATO RADIALE 2 USCITE IN Y
 Radial single side twin head driven tool in Y
 Radial angetriebenes Werkzeug 2 Ausgaenge in Y

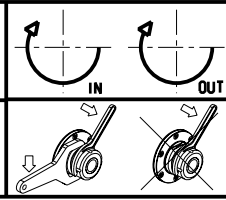

M.T. srl
 Via Casino Albini 480
 Tel. 0541/956034-957884
 Fax 0541/956341
 47842 S. GIOVANNI IN M. (RN)
 e-mail: mtma@mtmarchetti.com
 http://www.mtmarchetti.com

PRODUZIONE MODULI ROTANTI

PAGINA NKM090-2-00

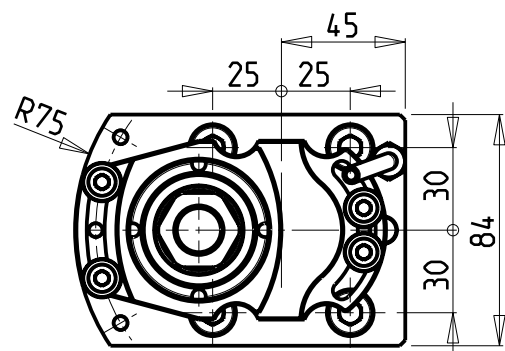
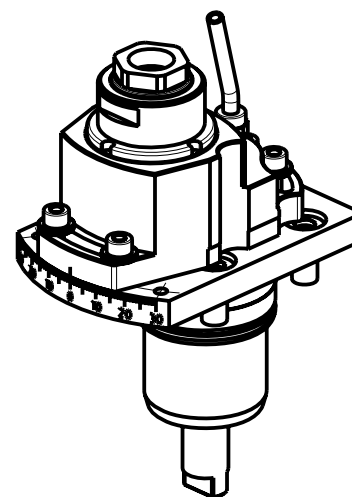
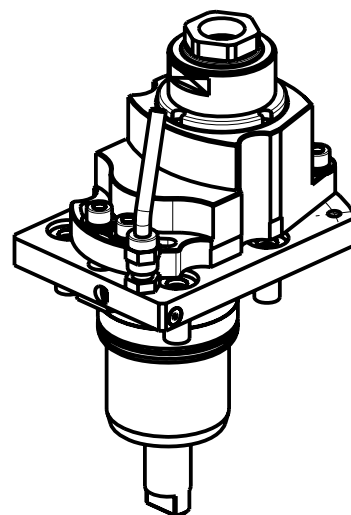
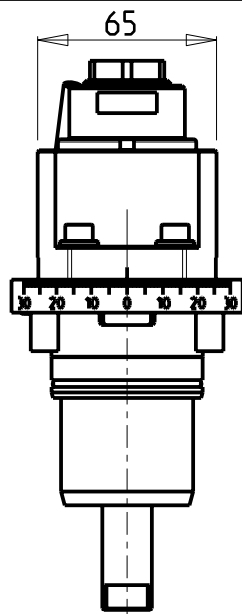
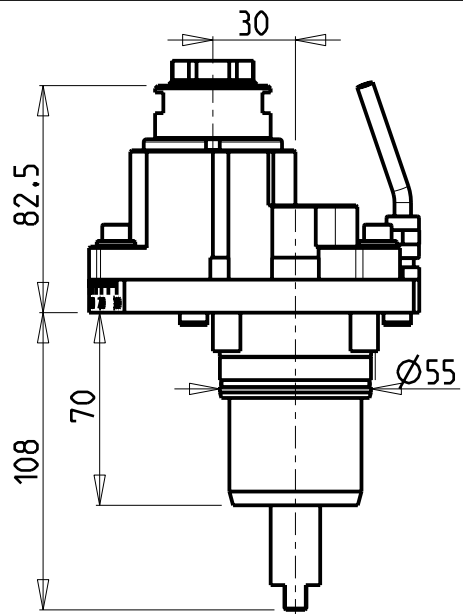

ATTENZIONE - ATTENTION - ACHTUNG

- Per lo smontaggio degli utensili utilizzare sempre la chiave di contrasto come indicato nel manuale d'uso.
- For disassembly of the tools use always the contrast key as mentioned in the user instructions.
- Fuer das Abmontieren der Werkzeuge immer den Gegenschlüssel benutzen wie in der Bedienungsanleitung erwahnt.

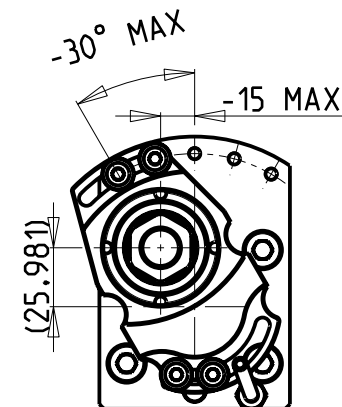
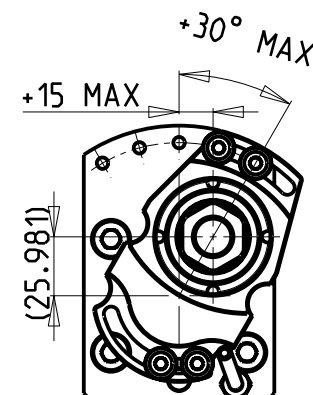

Cod. MT	Mandrino Spindle Spindel	I	RPM	Coppia Max Max Torque Max Drehmoment	Lubrificazione est. Ext. coolant Aussenkuehlung	CHIAVI NON INCLUDE Keys not included Schluessel nicht einbegriffen	
NKM0621025	ERA25	1:1	6000	30Nm	X	CHUB36	CHUB27

NAKAMURA-TOME

WT150/250 - WT15011/25011 - WTW150 - WTS150 - SUPER NTM3 - SUPER NTJ - SUPER NTJX - SC200/250
 NTY3 250 - TW10M/MY/MM/MMY/MMYY-TW20M/MY/MM/MMY/MMYY 16 ST.

MODULO MOTORIZZATO RADIALE ORIENTABILE ±30° DISASSATO 30mm

Radial ±30°adjustable angle driven tool re-directed by 30mm

Radial angetriebenes Werkzeug schwenkbar ±30° achsversetzt um 30mm

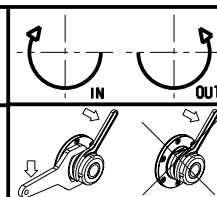

M.T. srl

Via Casino Albini 480
 Tel. 0541/956034-957884

Fax 0541/956341

47842 S. GIOVANNI IN M. (RN)

e-mail: mtma@mtmarchetti.com

http://www.mtmarchetti.com

PRODUZIONE MODULI ROTANTI



PAGINA NKM135-2-00

ATTENZIONE - ATTENTION - ACHTUNG

- Per lo smontaggio degli utensili utilizzare sempre la chiave di contrasto come indicato nel manuale d'uso.
- For disassembly of the tools use always the contrast key as mentioned in the user instructions.
- Fuer das Abmontieren der Werkzeuge immer den Gegenschlüssel benutzen wie in der Bedienungsanleitung erwäehnt.

- Chiave inclusa
- Key included
- Schlüssel inbegriffen

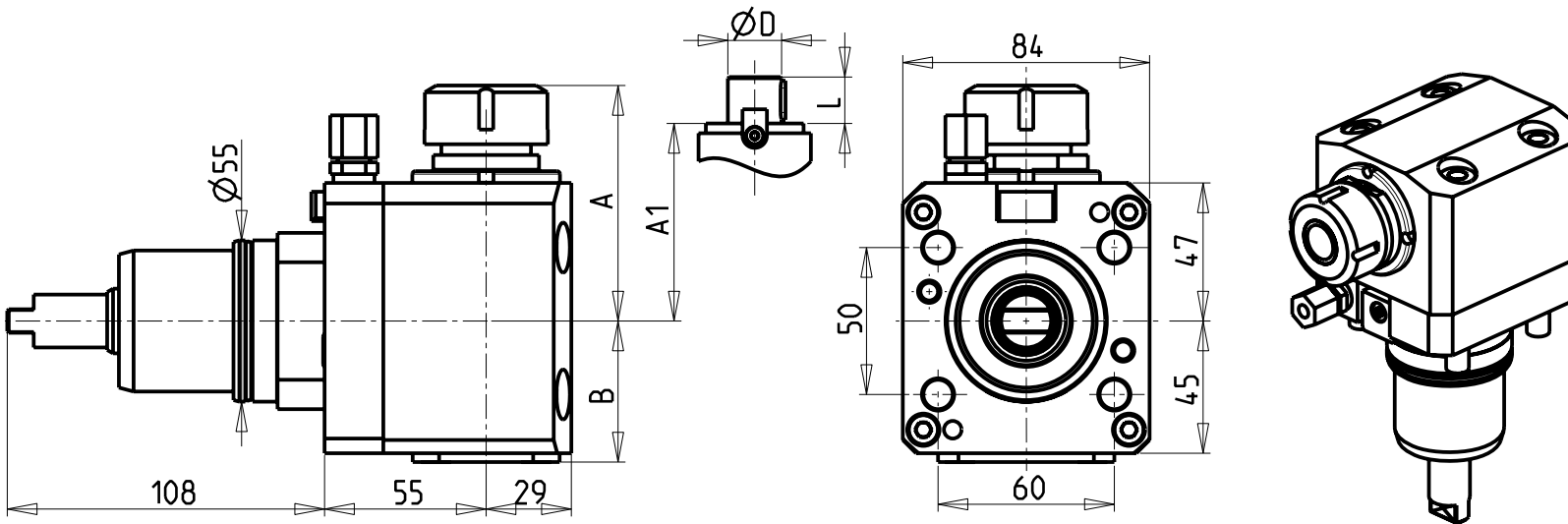

Cod. MT	Mandrino Spindel Spindel	I	RPM	Coppia Max Max Torque Max Drehmoment	Reversibile lato mandrino/contromandrino Reversible sub/main spindle side Umkehrbare Spindel-seite/Gegenspindel-seite	Lubr. interna Coolant through Innenkühlung	Lubr. esterna Ext. coolant Aussenkühlung	A	A1	B	D	L	CHIAVI NON INCLUDE Keys not included Schlüssel nicht einbegriffen	
NKM0021620	ER20	1:1	6000	50Nm	X		X	80.16	-	48	-	-	CHUB36	CHSTER20
NKM0021820	ER20	1:1	6000	50Nm	X	P=70bar	X	80.16	-	58	-	-	CHUB36	CHSTER20
NKM0021420	ER A 20	1:1	6000	50Nm	X		X	69.23	-	48	-	-	CHUB36	CHUB22
NKM0021425	ER25	1:1	6000	50Nm	X		X	80.16	-	48	-	-	CHUB36	CHSTER25
NKM0021625	ER25	1:1	6000	50Nm	X	P=70bar	X	80.16	-	58	-	-	CHUB36	CHSTER25
NKM0022432	ER32	1:1	6000	50Nm	X		X	97.66	-	48	-	-	CHUB36	CHSTER32
NKM0022532	ER32	1:1	6000	50Nm	X	P=70bar	X	97.66	-	57.5	-	-	CHUB36	CHSTER32
NKM0021617	Ø16x17	1:1	6000	50Nm	X		X	-	63	48	16	17	CHUB36	CH_VTCROCE_M08 ■
NKM0022219	Ø22x19	1:1	6000	50Nm	X		X	-	63	48	22	19	CHUB36	CH_VTCROCE_M10 ■
NKM0022721	Ø27x21	1:1	6000	50Nm	X		X	-	65.5	48	27	21	CHUB36	CH_VTCROCE_M12 ■
NKM0022737	Ø27x37	1:1	6000	50Nm	X		X	-	65.5	48	27	37	CHUB36	CH_VTCROCE_M12 ■

NAKAMURA-TOME

WT150/250 - WT15011/25011 - WTW150 - WTS150 - SUPER NTM3 - SUPER NTJ - SUPER NTJX - SC200/250
 NTY3_250 - TW10M/MY/MM/MYY - TW20M/MY/MM/MYY 16 ST.

MODULO MOTORIZZATO ASSIALE H=55mm

Axial driven tool H=55mm

Axial angetriebenes Werkzeug H=55mm

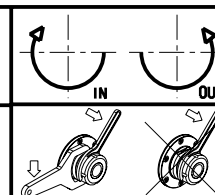

M.T. srl

Via Casino Albini 480
 Tel. 0541/956034-957884
 Fax 0541/956341
 47842 S. GIOVANNI IN M. (RN)
 e-mail: mtma@mtmarchetti.com
 http://www.mtmarchetti.com

PRODUZIONE MODULI ROTANTI



PAGINA NKM150-2-10

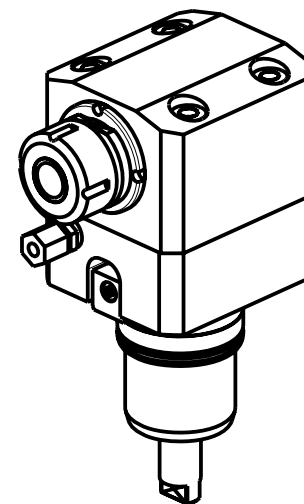
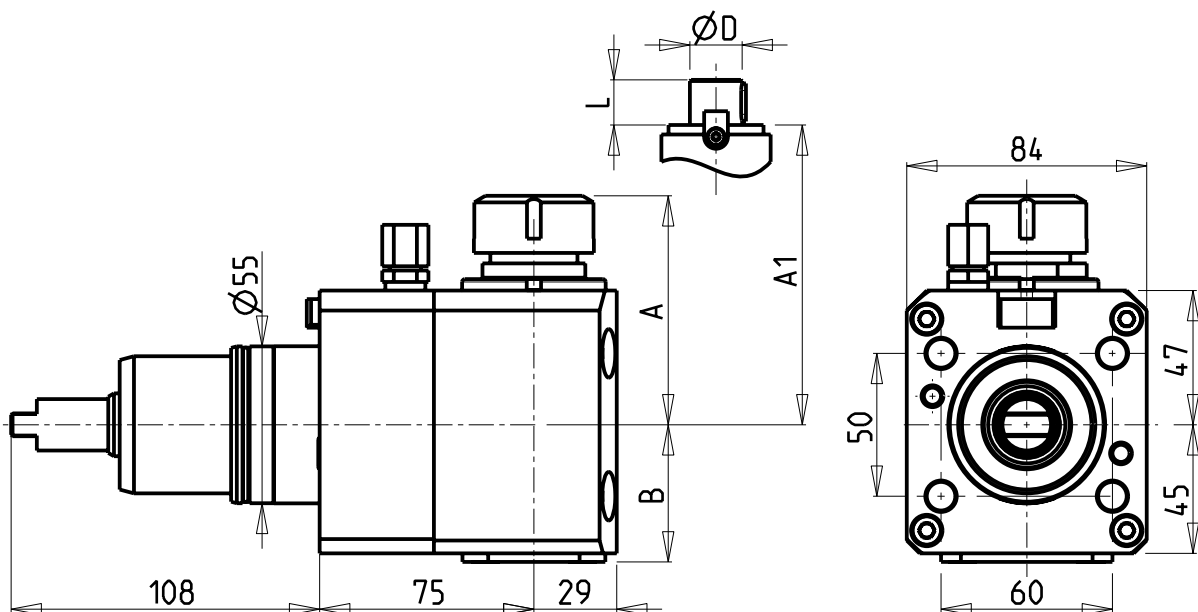

ATTENZIONE - ATTENTION - ACHTUNG

- Per lo smontaggio degli utensili utilizzare sempre la chiave di contrasto come indicato nel manuale d'uso.
- For disassembly of the tools use always the contrast key as mentioned in the user instructions.
- Fuer das Abmontieren der Werkzeuge immer den Gegenschlüssel benutzen wie in der Bedienungsanleitung erwäehnt.

- Chiave inclusa
- Key included
- Schlüssel inbegriffen

Cod. MT	Mandrino Spindle Spindel	I	RPM	Coppia Max Max Torque Max Drehmoment	Reversibile lato mandrino/contromandrino Reversible sub/main spindle side Umkehrbare Spindel-seite/ Gegenspindel-seite	Lubr.interna Coolant through Innenkuehlung	Lubr. esterna Ext. coolant Ausseinkuehlung	A	A1	B	D	L	CHIAVI NON INCLUSE Keys not included Schluesssel nicht einbegriffen	
NKM0061620	ER20	1:1	6000	50Nm	X			80.16	-	48	-	-	CHUB36	CHSTER20
NKM0061820	ER20	1:1	6000	50Nm	X	P=70bar		80.16	-	57.5	-	-	CHUB36	CHSTER20
NKM0061420	ER A 20	1:1	6000	50Nm	X			69.23	-	48	-	-	CHUB36	CHUB22
NKM0061425	ER25	1:1	6000	50Nm	X			80.16	-	48	-	-	CHUB36	CHSTER25
NKM0061625	ER25	1:1	6000	50Nm	X	P=70bar		80.16	-	57.5	-	-	CHUB36	CHSTER25
NKM0062432	ER32	1:1	6000	50Nm	X			97.66	-	48	-	-	CHUB36	CHSTER32
NKM0062532	ER32	1:1	6000	50Nm	X	P=70bar		92.16	-	57.5	-	-	CHUB36	CHSTER32
NKM0061617	Ø16x17	1:1	6000	50Nm	X			-	63	48	16	17	CHUB36	CH_VTCROCE_M08 ▪
NKM0062219	Ø22x19	1:1	6000	50Nm	X			-	63	48	22	19	CHUB36	CH_VTCROCE_M10 ▪
NKM0062721	Ø27x21	1:1	6000	50Nm	X			-	65.5	48	27	21	CHUB36	CH_VTCROCE_M12 ▪

NAKAMURA-TOME

WT250 - WT15011/25011 - WTW150 - WTS150 - SC200/250 - SUPER NTJX - NTY3 250

MODULO MOTORIZZATO ASSIALE H=75mm

Axial driven tool H=75mm

Axial angetriebenes Werkzeug H=75mm

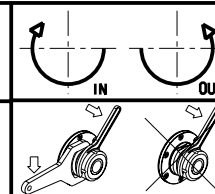

M.T. srl

Via Casino Albini 480
Tel. 0541/956034-957884

Fax 0541/956341

47842 S. GIOVANNI IN M. (RN)
e-mail: mtma@mtmarchetti.com
http://www.mtmarchetti.com

PRODUZIONE MODULI ROTANTI



PAGINA NKM150-2-20

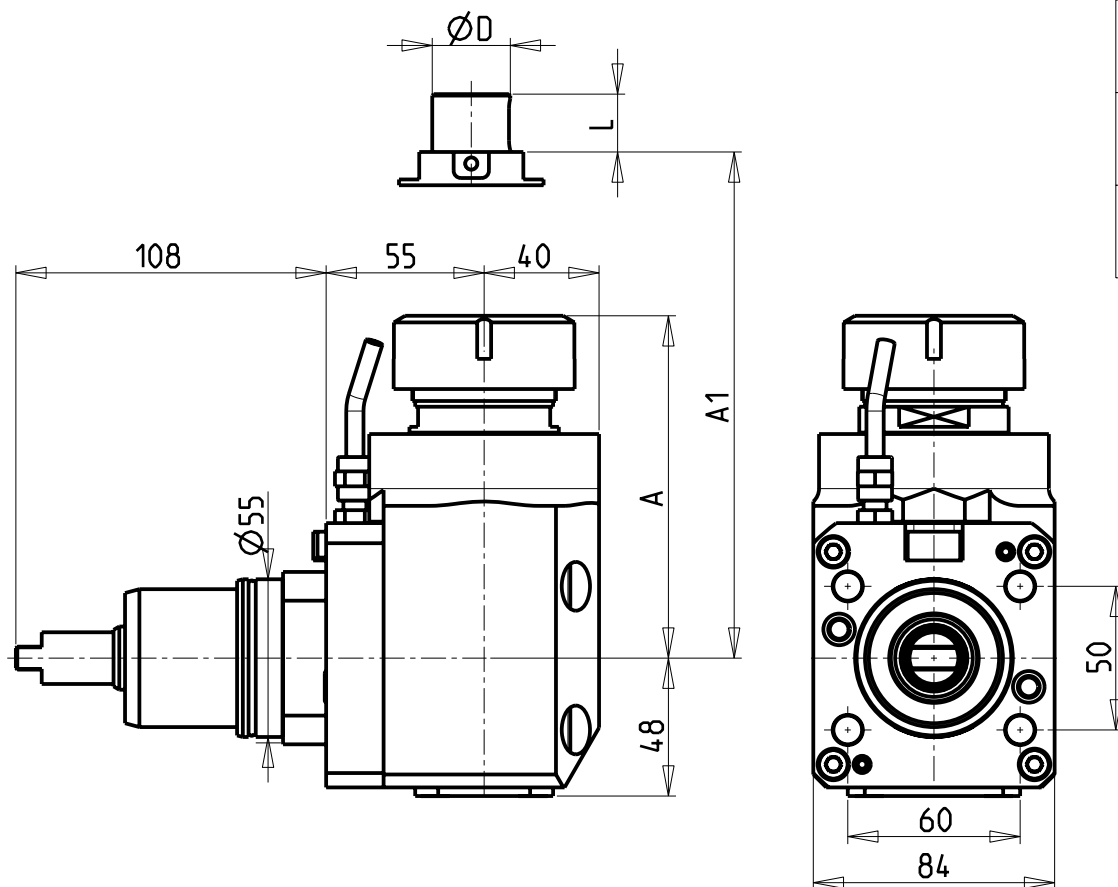

**CUSCINETTI MAGGIORATI
PER LAVORAZIONI PESANTI**

Reinforced bearings for heavy machining

Vergroesserte lager fuer schwerere Bearbeitungen

ATTENZIONE - ATTENTION - ACHTUNG

- Per lo smontaggio degli utensili utilizzare sempre la chiave di contrasto come indicato nel manuale d'uso.
- For disassembly of the tools use always the contrast key as mentioned in the user instructions.
- Fuer das Abmontieren der Werkzeuge immer den Gegenschlüssel benutzen wie in der Bedienungsanleitung erwahnt.

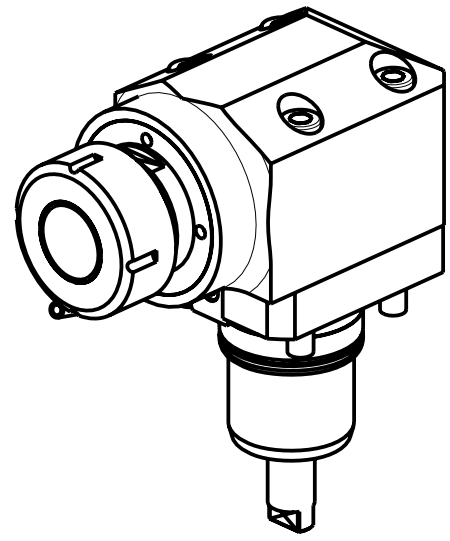

Cod. MT	Mandrino Spindle Spindel	I	RPM	Coppia Max Max Torque Max Drehmoment	Reversibile lato mandrino/contromandrino Reversible sub/main spindle side Umkehrbare Spindel-seite/ Gegenspindel-seite	Lubrificazione est. Ext. coolant Aussenkuehlung	A	A1	ØD	L	CHIAVI NON INCLUSE Keys not included Schluessel nicht einbegriffen	
NKM0070140	ER40	1:1	6000	50Nm	X	X	119.16				CHUB46	CHSTER40
NKM0072519	Ø1"x19	1:1	6000	50Nm	X	X		91.5	1"	19	CHUB46	CH_VTCROCE_M12 •
NKM0072721	Ø27x21	1:1	6000	50Nm	X	X		91.5	27	20	CHUB36	CH_VTCROCE_M12 •

- Chiave inclusa
- Key included
- Schluessel inbegriffen

NAKAMURA-TOME

WT150/250 - WT15011/25011 - WTW150 - WTS150 - SUPER NTM3 - SUPER NTJ - SUPER NTJX - SC200/250 NTY3_250 - TW10M/MY/MM/MMY/MMYY-TW20M/MY/MM/MMY/MMYY 16 ST.

MODULO MOTORIZZATO ASSIALE MAGGIORATO H=55mm
Axial reinforced driven tool H=55mm
Axial angetriebenes Werkzeug vergroessert H=55mm

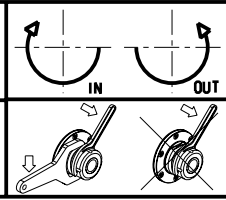

M.T. srl
Via Casino Albini 480
Tel. 0541/956034-957884
Fax 0541/956341
47842 S. GIOVANNI IN M. (RN)
e-mail: mtma@mtmarchetti.com
http://www.mtmarchetti.com

PRODUZIONE MODULI ROTANTI

PAGINA NKM170-2-10

**CUSCINETTI MAGGIORATI
PER LAVORAZIONI PESANTI**

Reinforced bearings for heavy machining

Vergroesserte lager fuer schwerere Bearbeitungen

ATTENZIONE - ATTENTION - ACHTUNG

- Per lo smontaggio degli utensili utilizzare sempre la chiave di contrasto come indicato nel manuale d'uso.
- For disassembly of the tools use always the contrast key as mentioned in the user instructions.
- Fuer das Abmontieren der Werkzeuge immer den Gegenschlüssel benutzen wie in der Bedienungsanleitung erwäehnt.

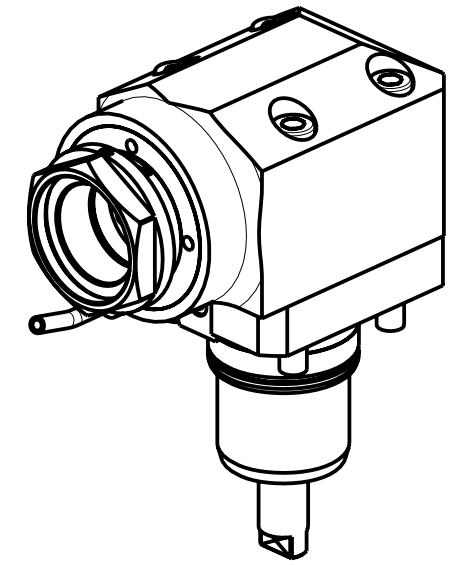
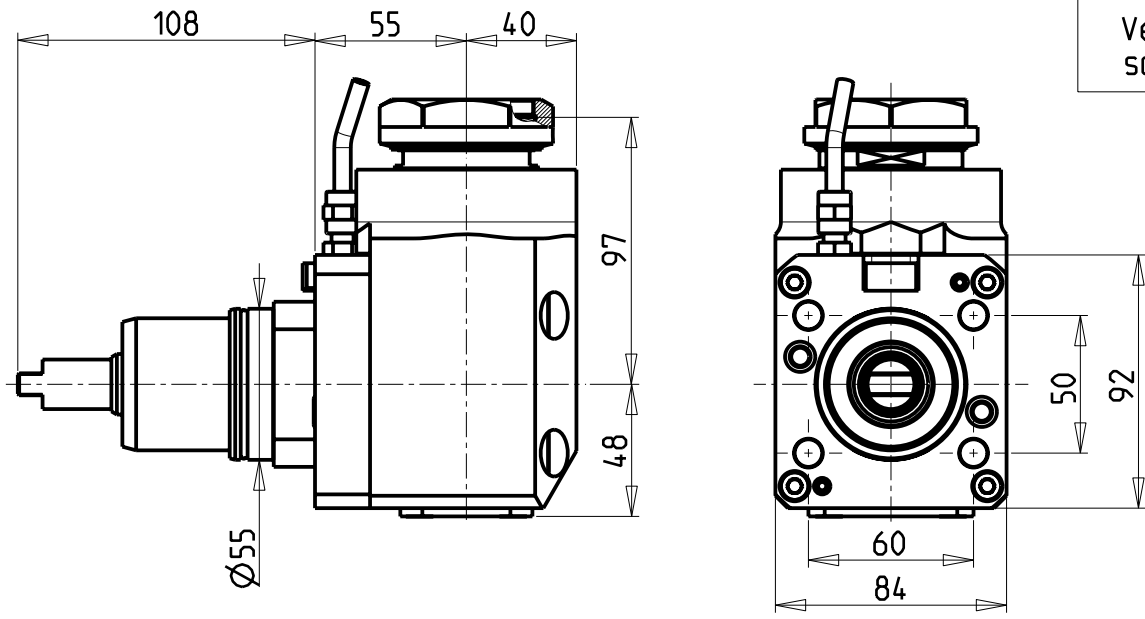

PER PORTAUTENSILI MODULARI MTSK-50 VEDI PAG. TBL300-1-50
FOR MTSK-50 QUIK CHANGE TOOLHOLDERS CLAMPINGS SEE PAGE TBL300-1-50
FUER MTSK-50 MODULARE WERKZEUGAUFNAHMEN SIEHE SEITE TBL300-1-50

Cod. MT	Mandrino Spindle Spindel	I	RPM	Coppia Max Max Torque Max Drehmoment	Reversibile lato mandrino/contromandrino Reversible sub/main spindle side Umkehrbare Spindelseite/ Gegenspindelseite	Lubrificazione est. Ext. coolant Aussenkuehlung	CHIAVI NON INCLUSE Keys not included Schluessel nicht einbegriffen	
NKM1000150	MTSK-50	1:1	6000	50Nm	X	X	CHUB46	CHUB55

NEW

NAKAMURA-TOME

WT150/250 - WT150II/250II - WTW150 - WTS150 - SUPER NTM3 - SUPER NTJ - SUPER NTJX - SC200/250
NTY3 250 - TW10M/MY/MM/MMY/MMYY-TW20M/MY/MM/MMY/MMYY 16 ST.

MODULO MOTORIZZATO ASSIALE MAGGIORATO MTSK H=55mm
Axial MTSK reinforced driven tool H=55mm
Axial MTSK angetriebenes Werkzeug vergroessert H=55mm

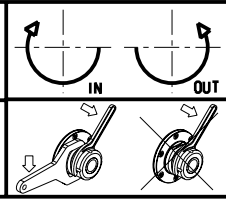

M.T. srl
Via Casino Albini 480
Tel. 0541/956034-957884
Fax 0541/956341
47842 S. GIOVANNI IN M. (RN)
e-mail: mtma@mtmarchetti.com
http://www.mtmarchetti.com

PRODUZIONE MODULI ROTANTI

PAGINA NKM170-2-10-K

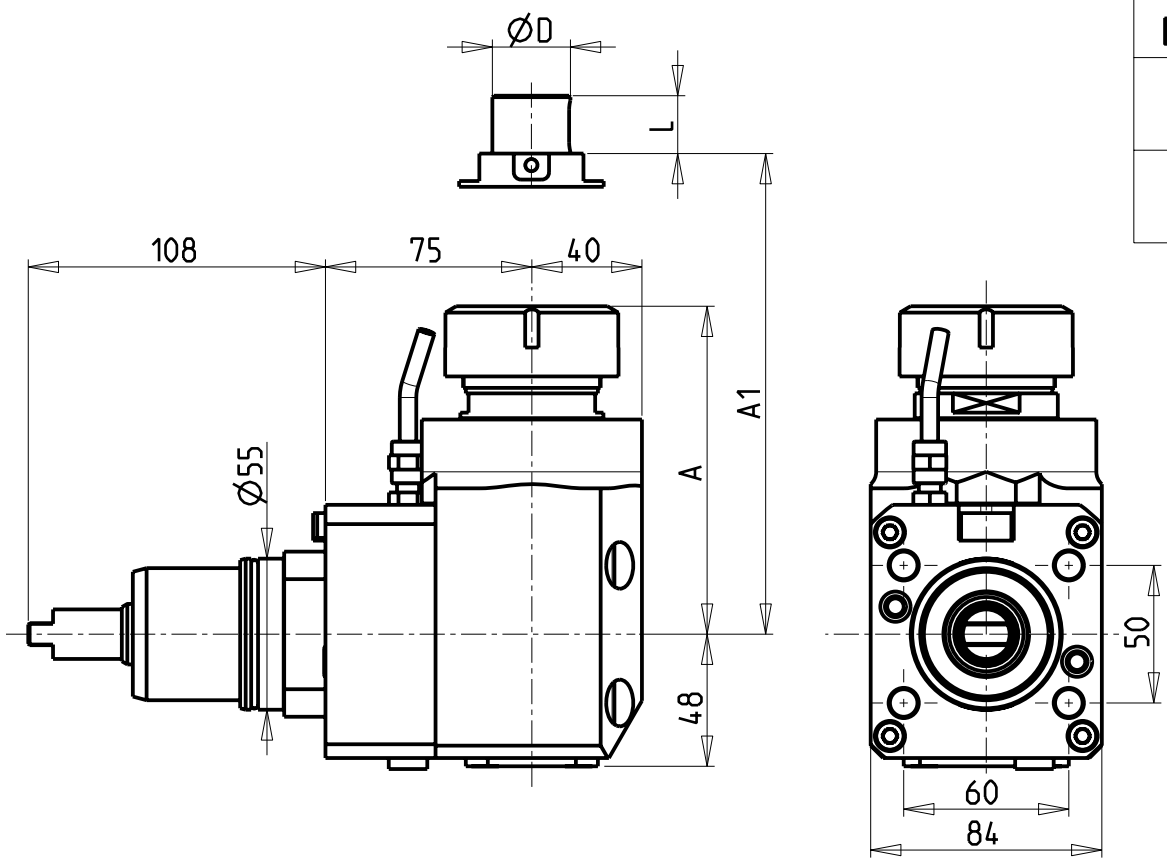

**CUSCINETTI MAGGIORATI
PER LAVORAZIONI PESANTI**

Reinforced bearings for
heavy machining

Vergroesserte lager fuer
schwerere Bearbeitungen

ATTENZIONE - ATTENTION - ACHTUNG

- Per lo smontaggio degli utensili utilizzare sempre la chiave di contrasto come indicato nel manuale d'uso.
- For disassembly of the tools use always the contrast key as mentioned in the user instructions.
- Fuer das Abmontieren der Werkzeuge immer den Gegenschlüssel benutzen wie in der Bedienungsanleitung erwaeht.

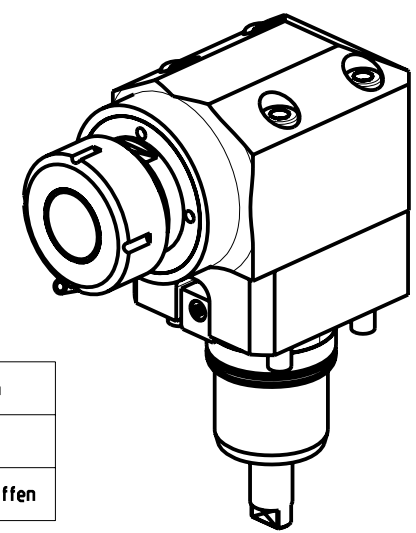

- Chiave inclusa
- Key included
- Schluessel inbegriffen

Cod. MT	Mandrino Spindle Spindel	I	RPM	Coppia Max Max Torque Max Drehmoment	Reversibile lato mandrino/contromandrino Reversible sub/main spindle side Umkehrbare Spindel-seite/ Gegenspindel-seite	Lubrificazione est. Ext. coolant Aussenkuehlung	A	A1	ØD	L	CHIAVI NON INCLUSE Keys not included Schluessel nicht einbegriffen	
NKM0990140	ER40	1:1	6000	50Nm	X	X	119.16	-	-	-	CHUB46	CHSTER40
NKM0992519	Ø1"x19	1:1	6000	50Nm	X	X	-	91.5	1"	19	CHUB46	CH_VTCROCE_M12
NKM0992721	Ø27x21	1:1	6000	50Nm	X	X	-	91.5	27	20	CHUB36	CH_VTCROCE_M12

NEW
NEW
NEW

NAKAMURA-TOME
WT250 - WT15011/25011 - WTW150 - WTS150 - SC200/250 - SUPER NTJX - NTY3 250

MODULO MOTORIZZATO ASSIALE MAGGIORATO H=75mm
Axial reinforced driven tool H=75mm
Axial angetriebenes Werkzeug vergroessert H=75mm

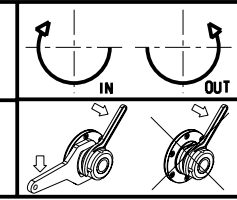

M.T. srl
Via Casino Albini 480
Tel. 0541/956034-957884
Fax 0541/956341
47842 S. GIOVANNI IN M. (RN)
e-mail: mtma@mtmarchetti.com
http://www.mtmarchetti.com

PRODUZIONE MODULI ROTANTI

PAGINA NKM170-2-20

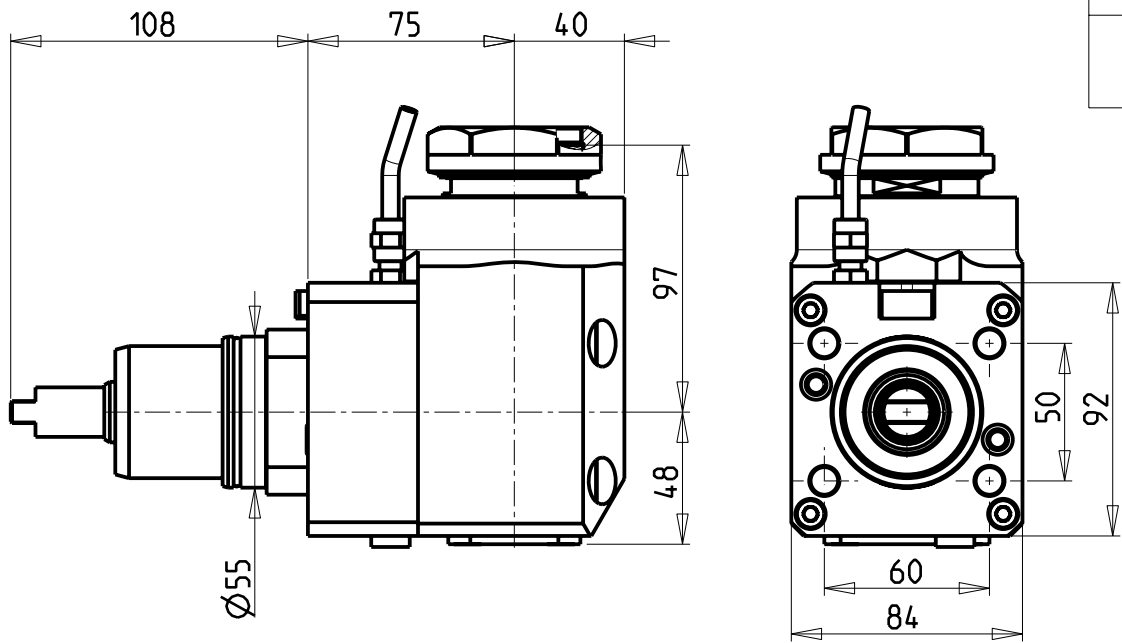

**CUSCINETTI MAGGIORATI
PER LAVORAZIONI PESANTI**

Reinforced bearings for
heavy machining

Vergroesserte Lager fuer
schwerere Bearbeitungen

ATTENZIONE - ATTENTION - ACHTUNG

- Per lo smontaggio degli utensili utilizzare sempre la chiave di contrasto come indicato nel manuale d'uso.
- For disassembly of the tools use always the contrast key as mentioned in the user instructions.
- Fuer das Abmontieren der Werkzeuge immer den Gegenschlüssel benutzen wie in der Bedienungsanleitung erwäehnt.

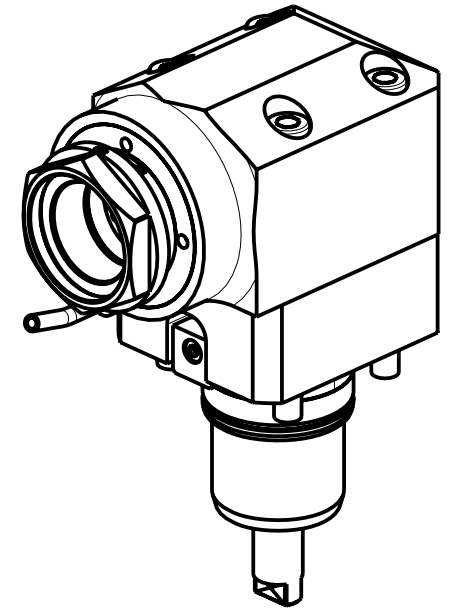

PER PORTAUTENSILI MODULARI MTSK-50 VEDI PAG. TBL300-1-50
FOR MTSK-50 QUIK CHANGE TOOLHOLDERS CLAMPINGS SEE PAGE TBL300-1-50
FUER MTSK-50 MODULARE WERKZEUGAUFNAHMEN SIEHE SEITE TBL300-1-50

Cod. MT	Mandrino Spindle Spindel	I	RPM	Coppia Max Max Torque Max Drehmoment	Reversibile lato mandrino/contromandrino Reversible sub/main spindle side Umkehrbare Spindelseite/Gegenspindelseite	Lubrificazione est. Ext. coolant Aussenkuehlung	CHIAVI NON INCLUSE Keys not included Schluesssel nicht einbegriffen	
NKM1010150	MTSK-50	1:1	6000	50Nm	X	X	CHUB46	CHUB55

NEW

NAKAMURA-TOME

WT250 - WT150II/250II - WTW150 - WTS150 - SC200/250 - SUPER NTJX - NTY3 250

MODULO MOTORIZZATO ASSIALE MAGGIORATO MTSK H=75mm
Axial MTSK reinforced driven tool H=75mm
Axial MTSK angetriebenes Werkzeug vergroessert H=75mm

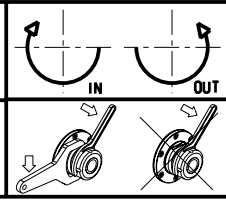

M.T. srl
Via Casino Albini 480
Tel. 0541/956034-957884
Fax 0541/956341
47842 S. GIOVANNI IN M. (RN)
e-mail: mtma@mtmarchetti.com
http://www.mtmarchetti.com

PRODUZIONE MODULI ROTANTI

PAGINA NKM170-2-20-K

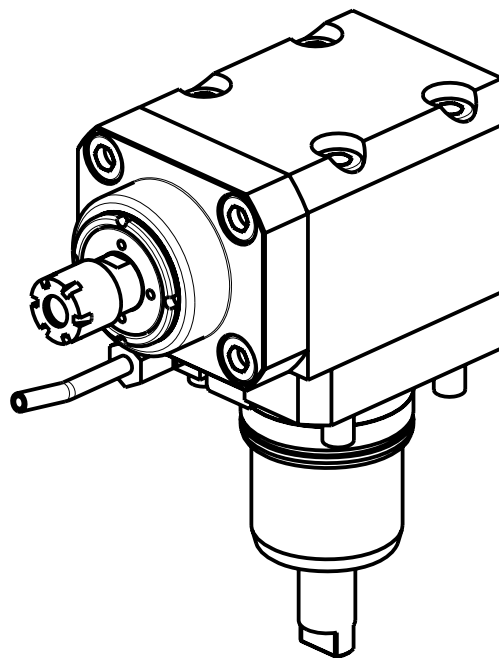
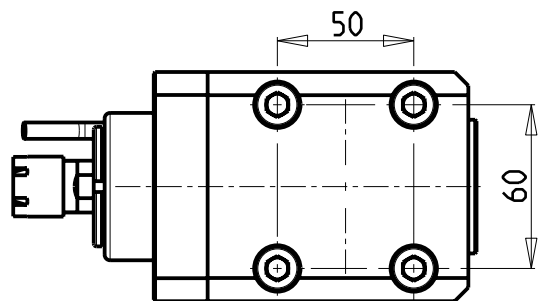
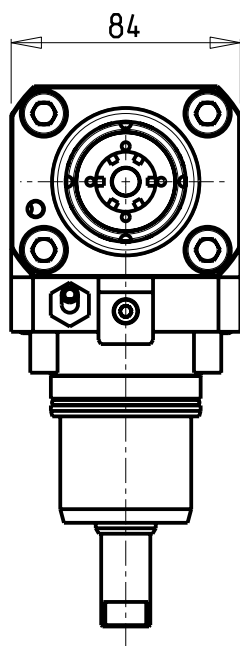
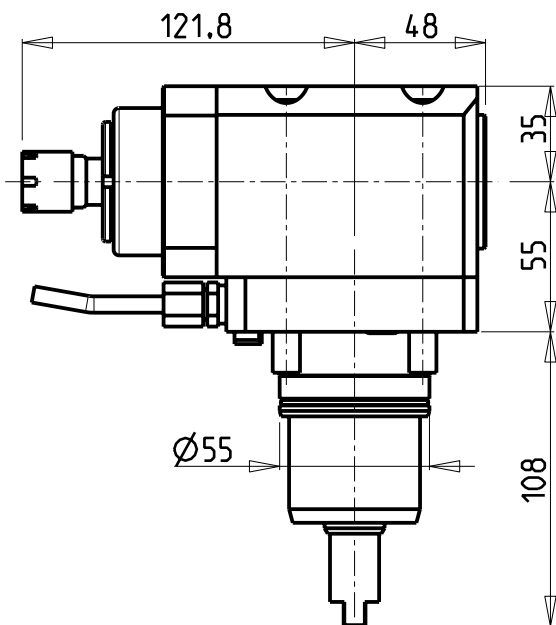

ATTENZIONE - ATTENTION - ACHTUNG

- Per lo smontaggio degli utensili utilizzare sempre la chiave di contrasto come indicato nel manuale d'uso.
- For disassembly of the tools use always the contrast key as mentioned in the user instructions.
- Fuer das Abmontieren der Werkzeuge immer den Gegenschlüssel benutzen wie in der Bedienungsanleitung erwäehnt.

ATTENZIONE - ATTENTION - ACHTUNG

- PRIMA DI UTILIZZARE IL MOTORIZZATO CONSULTARE LE ISTRUZIONI ALLEGATE!
- BEFORE USING THE DRIVEN TOOL, PLEASE CHECK THE ENCLOSED INSTRUCTION SHEET!
- VOR DER BENUTZUNG DES ANGETRIEBENEN WERKZEUGES, DIE BEILIEGENDEN INSTRUKTIONEN DURCHLESEN!

Cod. MT	Mandrino Spindle Spindel	I	RPM	Coppia Max Max Torque Max Drehmoment	Reversibile lato mandrino/contromandrino Reversible sub/main spindle side Umkehrbare Spindelseite/ Gegenspindelseite	Lubrificazione est. Ext. coolant Aussenkuehlung	CHIAVI INCLUSE Keys included Schluesssel einbegriffen	
NKM0050016	ER16	1:3	18000	10Nm	X	X	CHUB17	CHMNER16

NAKAMURA-TOME

WT150/250 - WT15011/25011 - WTW150 - WTS150 - SUPER NTM3 - SUPER NTJ - SUPER NTJX - SC200/250
 NTY3 250 - TW10M/MY/MM/MMY/MMYY-TW20M/MY/MM/MMY/MMYY 16 ST.

MODULO MOTORIZZATO ASSIALE MOLTIPLICATO I=1:3 H=55mm

Axial geared-up I=1:3 driven tool H=55mm

Axial angetriebenes Werkzeug uebersetzt I=1:3 H=55mm

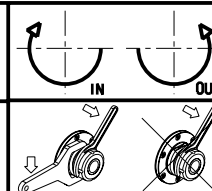

M.T. srl

Via Casino Albini 480
 Tel. 0541/956034-957884
 Fax 0541/956341

47842 S. GIOVANNI IN M. (RN)
 e-mail: mtma@mtmarchetti.com
 http://www.mtmarchetti.com

PRODUZIONE MODULI ROTANTI



PAGINA NKM205-2-10

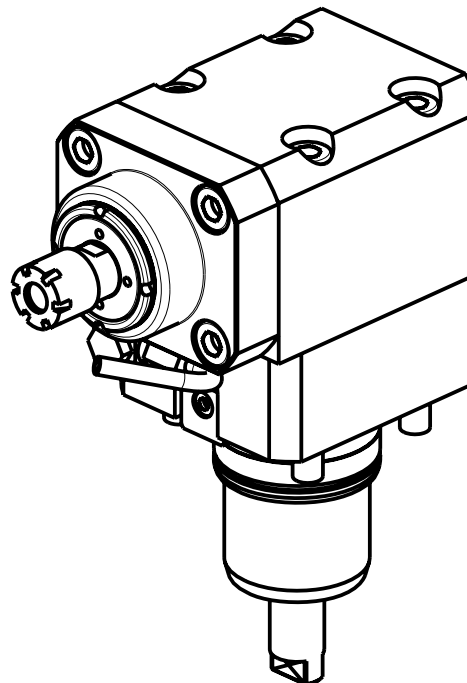
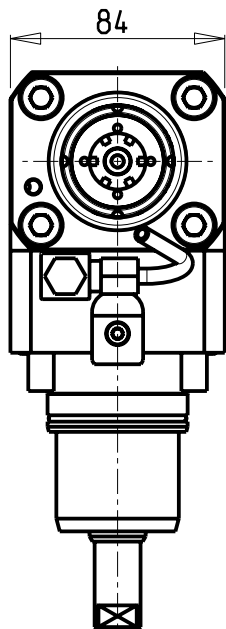
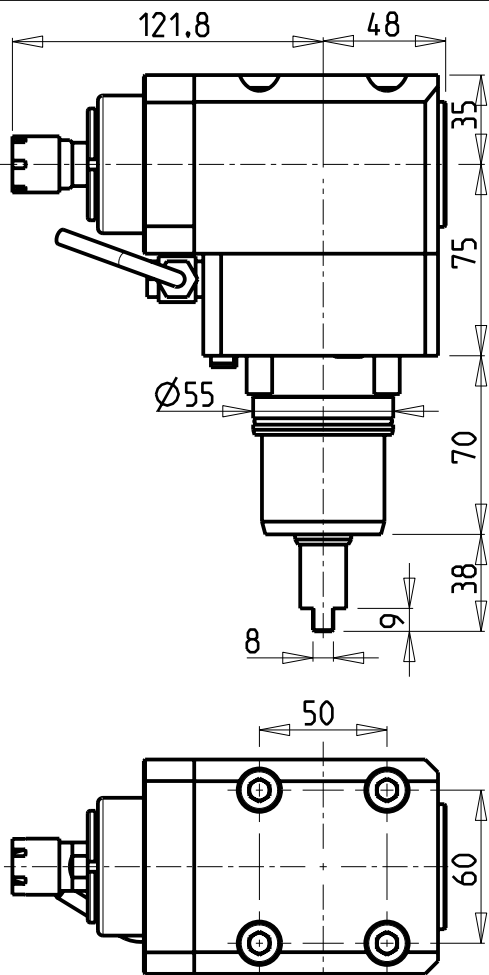

ATTENZIONE - ATTENTION - ACHTUNG

- Per lo smontaggio degli utensili utilizzare sempre la chiave di contrasto come indicato nel manuale d'uso.
- For disassembly of the tools use always the contrast key as mentioned in the user instructions.
- Fuer das Abmontieren der Werkzeuge immer den Gegenschlüssel benutzen wie in der Bedienungsanleitung erwäohnt.

ATTENZIONE - ATTENTION - ACHTUNG

- PRIMA DI UTILIZZARE IL MOTORIZZATO CONSULTARE LE ISTRUZIONI ALLEGATE!
- BEFORE USING THE DRIVEN TOOL, PLEASE CHECK THE ENCLOSED INSTRUCTION SHEET!
- VOR DER BENUTZUNG DES ANGETRIEBENEN WERKZEUGES, DIE BEILIEGENDEN INSTRUKTIONEN DURCHLESEN!

Cod. MT	Mandrino Spindle Spindel	I	RPM	Coppia Max Max Torque Max Drehmoment	Reversibile lato mandrino/contromandrino Reversible sub/main spindle side Umkehrbare Spindel-seite/ Gegenspindel-seite	Lubrificazione est. Ext. coolant Aussenkuehlung	CHIAVI INCLUSE Keys included Schluesel einbegriffen	
							CHUB17	CHMNER16
NKM0050216	ER16	1:3	18000	10Nm	X	X	CHUB17	CHMNER16

NAKAMURA-TOME

WT250 - WT15011/25011 - WTW150 - WTS150 - SC200 - SC250 - SUPER NTJX - NTY3 250

MODULO MOTORIZZATO ASSIALE MOLTIPLICATO I=1:3 H=75mm

Axial geared-up I=1:3 driven tool H=75mm

Axial angetriebenes Werkzeug uebersetzt I=1:3 H=75mm

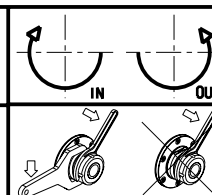

M.T. srl

Via Casino Albini 480
Tel. 0541/956034-957884
Fax 0541/956341

47842 S. GIOVANNI IN M. (RN)
e-mail: mtma@mtmarchetti.com
http://www.mtmarchetti.com

PRODUZIONE MODULI ROTANTI



PAGINA NKM205-2-20

ATTENZIONE - ATTENTION - ACHTUNG

- Per lo smontaggio degli utensili utilizzare sempre la chiave di contrasto come indicato nel manuale d'uso.
- For disassembly of the tools use always the contrast key as mentioned in the user instructions.
- Fuer das Abmontieren der Werkzeuge immer den Gegenschlüssel benutzen wie in der Bedienungsanleitung erwahnt.

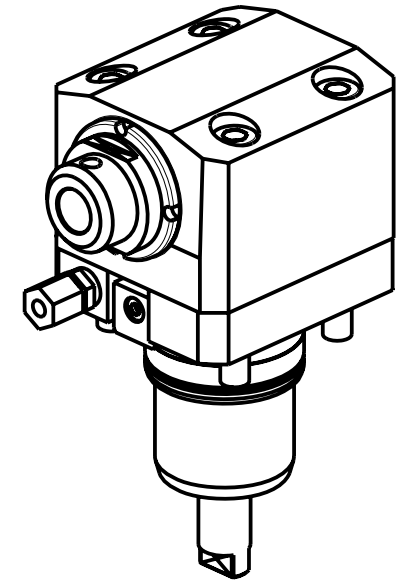
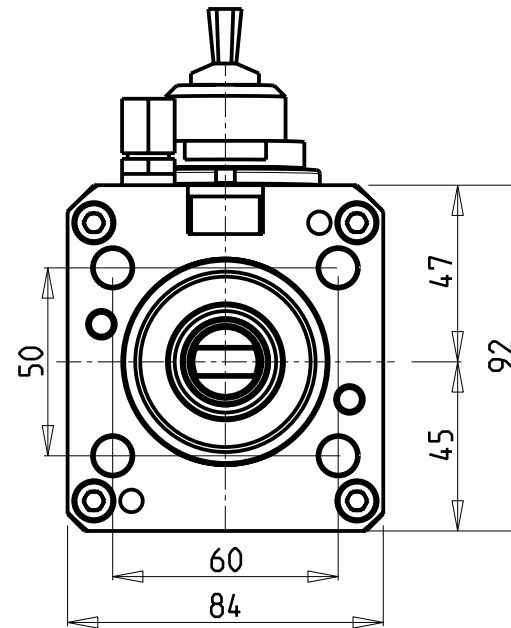
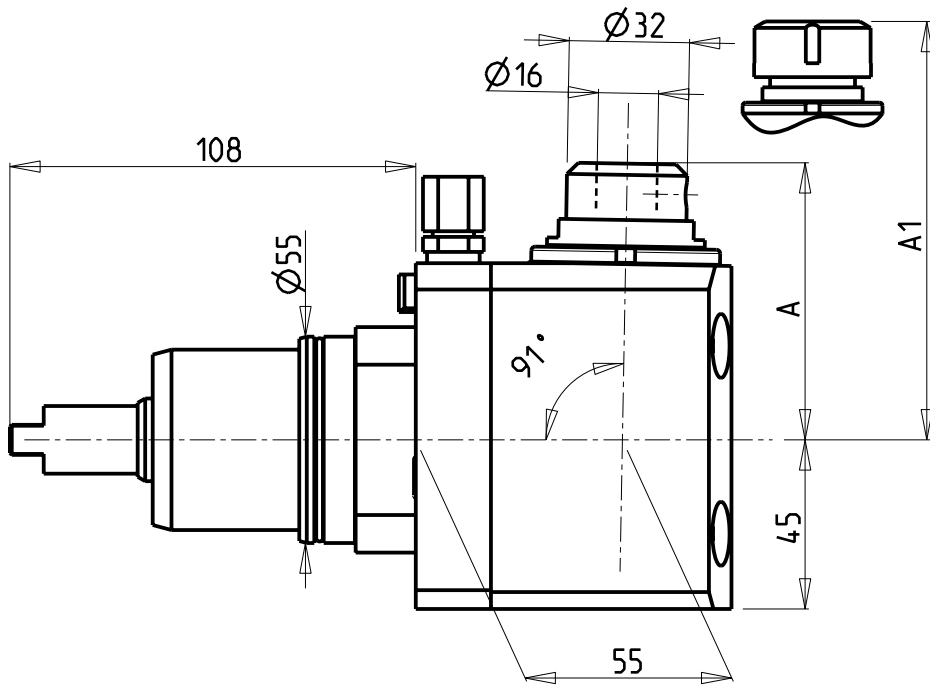

Cod. MT	Mandrino Spindle Spindel	I	RPM	Coppia Max Max Torque Max Drehmoment	Reversibile lato mandrino/contromandrino Reversible sub/main spindle side Umkehrbare Spindel-seite/ Gegenspindel-seite	Lubrificazione est. Ext. coolant Aussenkuehlung	A	A1	CHIAVI NON INCLUDE Keys not included Schluessel nicht einbegriffen	
NKM0039125	ER25	1:1	6000	50Nm	X	X	-	80.44	CHUB36	CHSTER25
NKM0039108	WELDON 8	1:1	6000	50Nm	X	X	76.5	-		
NKM0039110	WELDON 10	1:1	6000	50Nm	X	X	76.5	-		
NKM0039112	WELDON 12	1:1	6000	50Nm	X	X	76.5	-		
NKM0039116	WELDON 16	1:1	6000	50Nm	X	X	73.7	-		

NAKAMURA-TOME

WT150/250 - WT15011/25011 - WTW150 - WTS150 - SUPER NTM3 - SUPER NTJ - SUPER NTJX - SC200/250
 NTY3 250 - TW10M/MY/MM/MMY/MMYY-TW20M/MY/MM/MMY/MMYY 16 ST.

MODULO MOTORIZZATO ASSIALE PER POLIGONATURA INTERNA H=55mm

Axial driven tool for internal polygon-making H=55mm

Axial angetriebenes Werkzeug fuer interne Facettierung H=55mm

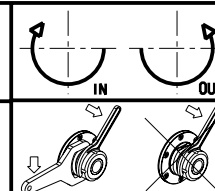

M.T. srl

Via Casino Albini 480
 Tel. 0541/956034-957884
 Fax 0541/956341
 47842 S. GIOVANNI IN M. (RN)
 e-mail: mtma@mtmarchetti.com
 http://www.mtmarchetti.com

PRODUZIONE MODULI ROTANTI



PAGINA NKM230-2-10

ATTENZIONE - ATTENTION - ACHTUNG

- Per lo smontaggio degli utensili utilizzare sempre la chiave di contrasto come indicato nel manuale d'uso.
- For disassembly of the tools use always the contrast key as mentioned in the user instructions.
- Fuer das Abmontieren der Werkzeuge immer den Gegenschlüssel benutzen wie in der Bedienungsanleitung erwäehnt.

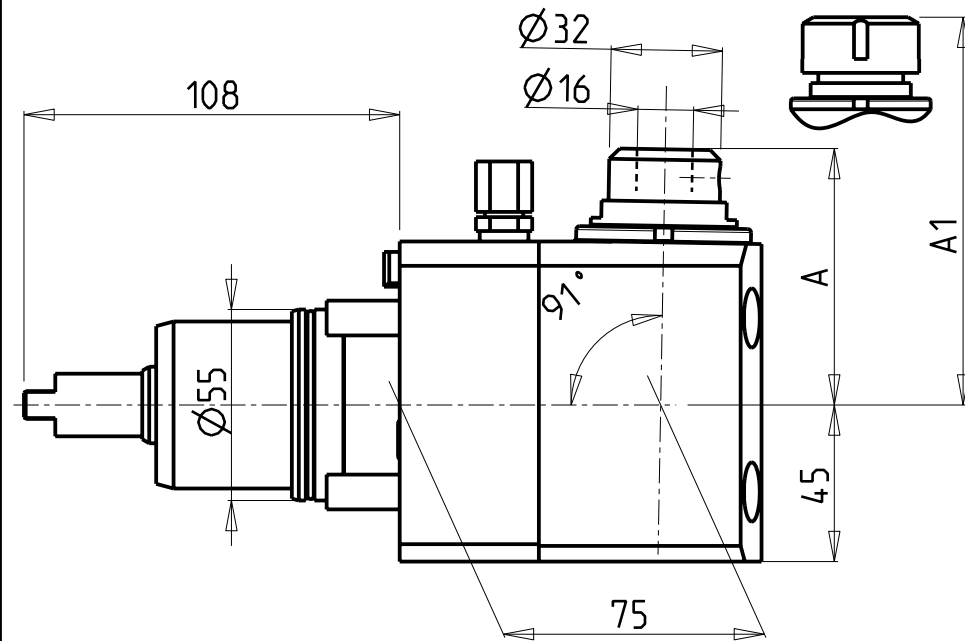
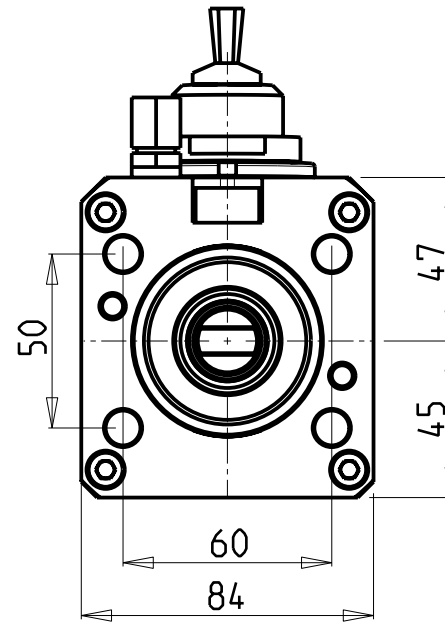
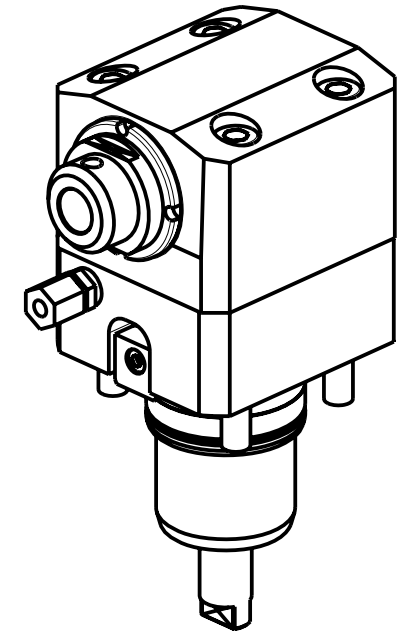

Cod. MT	Mandrino Spindle Spindel	i	RPM	Coppia Max Max Torque Max Drehmoment	Reversibile lato mandrino/contromandrino Reversible sub/main spindle side Umkehrbare Spindel-seite/ Gegenspindel-seite	Lubrificazione est. Ext. coolant Aussenkuehlung	A	A1	CHIAVI NON INCLUSE Keys not included Schluessel nicht einbegriffen	
									CHUB36	CHSTER25
NKM0069125	ER25	1:1	6000	50Nm	X	X	-	80.44	CHUB36	CHSTER25
NKM0069108	WELDON 8	1:1	6000	50Nm	X	X	76.5	-		
NKM0069110	WELDON 10	1:1	6000	50Nm	X	X	76.5	-		
NKM0069112	WELDON 12	1:1	6000	50Nm	X	X	76.5	-		
NKM0069116	WELDON 16	1:1	6000	50Nm	X	X	73.7	-		

NAKAMURA-TOME

WT250 - WT15011/25011 - WTW150 - WTS150 - SC200/250 - SUPER NTJX - NTY3 250

MODULO MOTORIZZATO ASSIALE PER POLIGONATURA INTERNA H=75mm

Axial driven tool for internal polygon-making H=75mm

Axial angetriebenes Werkzeug fuer interne Facettierung H=75mm

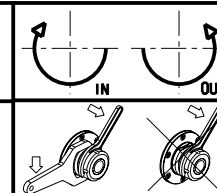

M.T. srl

Via Casino Albini 480
Tel. 0541/956034-957884

Fax 0541/956341

47842 S. GIOVANNI IN M. (RN)

e-mail: mtma@mtmarchetti.com

http://www.mtmarchetti.com

PRODUZIONE MODULI ROTANTI



PAGINA NKM230-2-20

ATTENZIONE - ATTENTION - ACHTUNG

- Per lo smontaggio degli utensili utilizzare sempre la chiave di contrasto come indicato nel manuale d'uso.
- For disassembly of the tools use always the contrast key as mentioned in the user instructions.
- Fuer das Abmontieren der Werkzeuge immer den Gegenschlüssel benutzen wie in der Bedienungsanleitung erwäehnt.

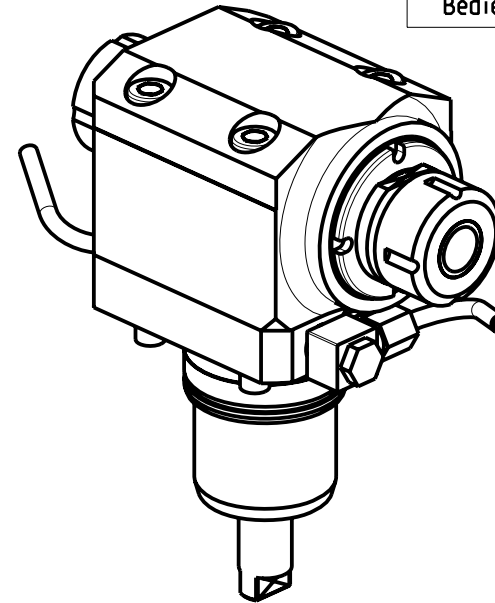
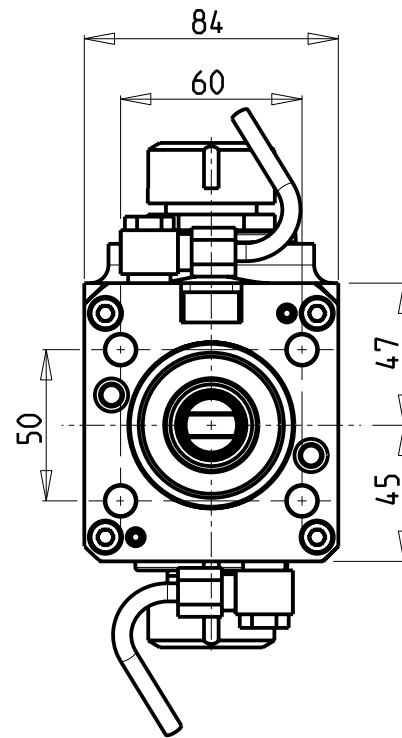
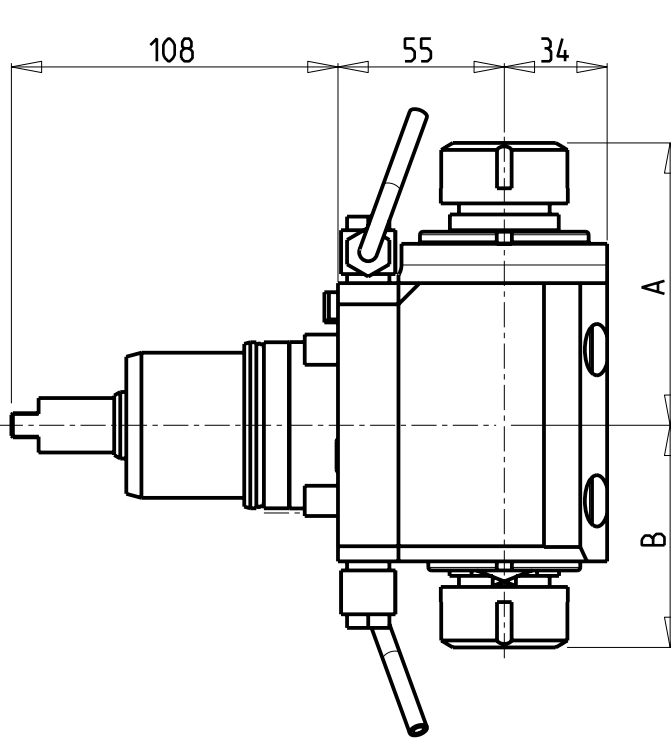

Cod. MT	Mandrino Spindle Spindel	I	RPM	Coppia Max Max Torque Max Drehmoment	Reversibile lato mandrino/contromandrino Reversible sub/main spindle side Umkehrbare Spindel-seite/ Gegenspindel-seite	Lubrificazione est. Ext. coolant Aussenkuehlung	A	B	CHIAVI NON INCLUSE Keys not included Schluessel nicht einbegriffen	
NKM0492525	ER25+ER25	1:1	6000	50Nm	X	X	93.36	73.46	CHSTER25	CHUB36+CHUB29
NKM0493232	ER32+ER32	1:1	6000	50Nm	X	X	100.56	78.96	CHSTER32	CHUB36

NAKAMURA-TOME

WT150/250 - WT15011/25011 - WTW150 - WTS150 - SUPER NTM3 - SUPER NTJ - SUPER NTJX - SC200/250
 NTY3 250 - TW10M/MY/MM/MMYY-TW20M/MY/MM/MMYY 16 ST.

MODULO MOTORIZZATO ASSIALE BISPORGENTE H=55mm

Axial opposite face twin driven tool H=55mm

Axial angetriebenes Werkzeug halb vorspringend H=55mm

M.T. srl

Via Casino Albini 480
 Tel. 0541/956034-957884
 Fax 0541/956341
 47842 S. GIOVANNI IN M. (RN)
 e-mail: mtma@mtmarchetti.com
 http://www.mtmarchetti.com

PRODUZIONE MODULI ROTANTI



PAGINA NKM240-2-10

ATTENZIONE - ATTENTION - ACHTUNG

- Per lo smontaggio degli utensili utilizzare sempre la chiave di contrasto come indicato nel manuale d'uso.
- For disassembly of the tools use always the contrast key as mentioned in the user instructions.
- Fuer das Abmontieren der Werkzeuge immer den Gegenschlüssel benutzen wie in der Bedienungsanleitung erwäehnt.

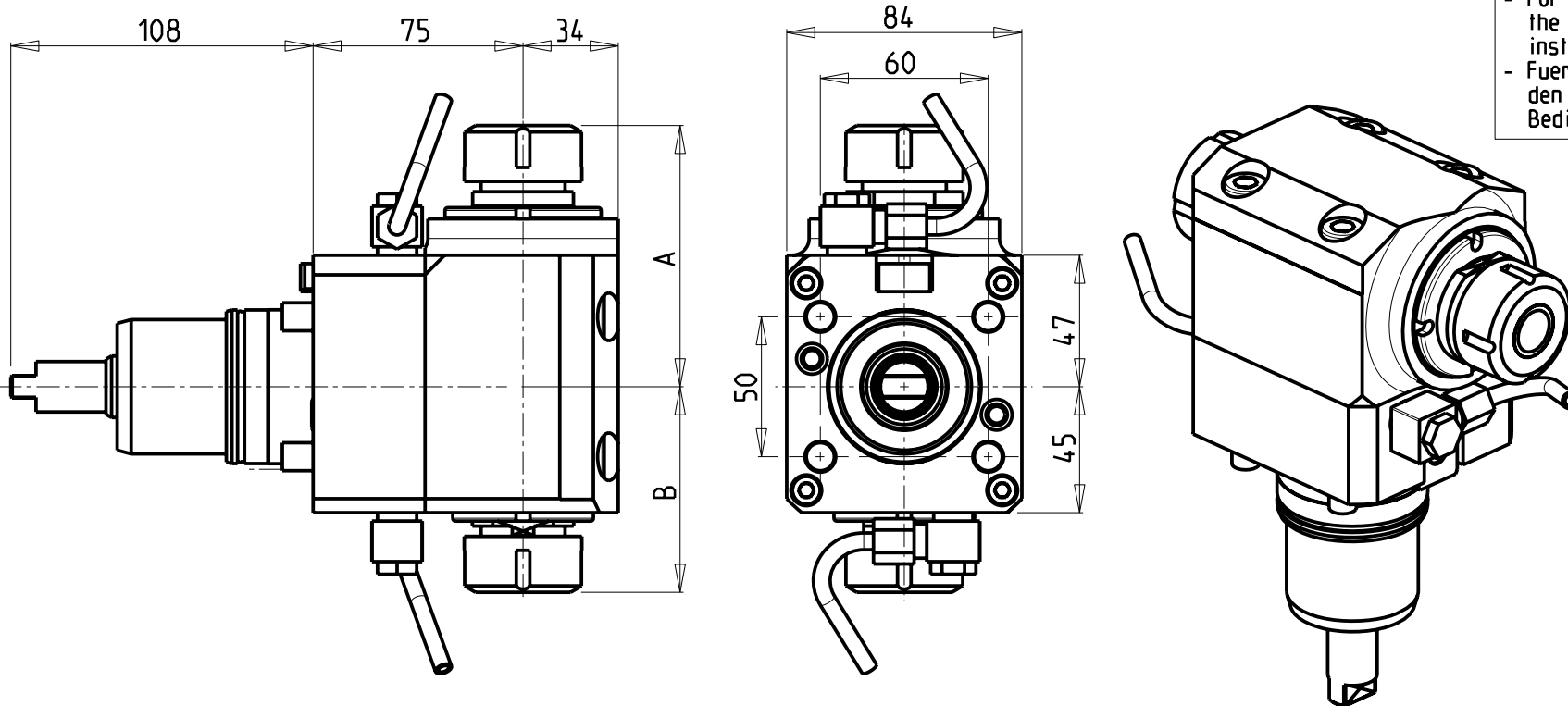

Cod. MT	Mandrino Spindle Spindel	I	RPM	Coppia Max Max Torque Max Drehmoment	Reversibile lato mandrino/contromandrino Reversible sub/main spindle side Umkehrbare Spindel-seite/ Gegenspindel-seite	Lubrificazione est. Ext. coolant Aussenkuehlung	A	B	CHIAVI NON INCLUSE Keys not included Schluesssel nicht einbegriffen	
NKM0502525	ER25+ER25	1:1	6000	50Nm	X	X	93.36	73.46	CHSTER25	CHUB36+CHUB29
NKM0503232	ER32+ER32	1:1	6000	50Nm	X	X	100.56	78.96	CHSTER32	CHUB36

NAKAMURA-TOME
 WT250 - WT15011/25011 - WTW150 - WTS150 - SC200/250 - SUPER NTJX - NTY3 250
 MODULO MOTORIZZATO ASSIALE BISPORGENTE H=75mm
 Axial opposite face twin driven tool H=75mm
 Axial angetriebenes Werkzeug halb vorspringend H=75mm



M.T. srl
 Via Casino Albini 480
 Tel. 0541/956034-957884
 Fax 0541/956341
 47842 S. GIOVANNI IN M. (RN)
 e-mail: mtma@mtmarchetti.com
 http://www.mtmarchetti.com

PRODUZIONE MODULI ROTANTI

PAGINA NKM240-2-20

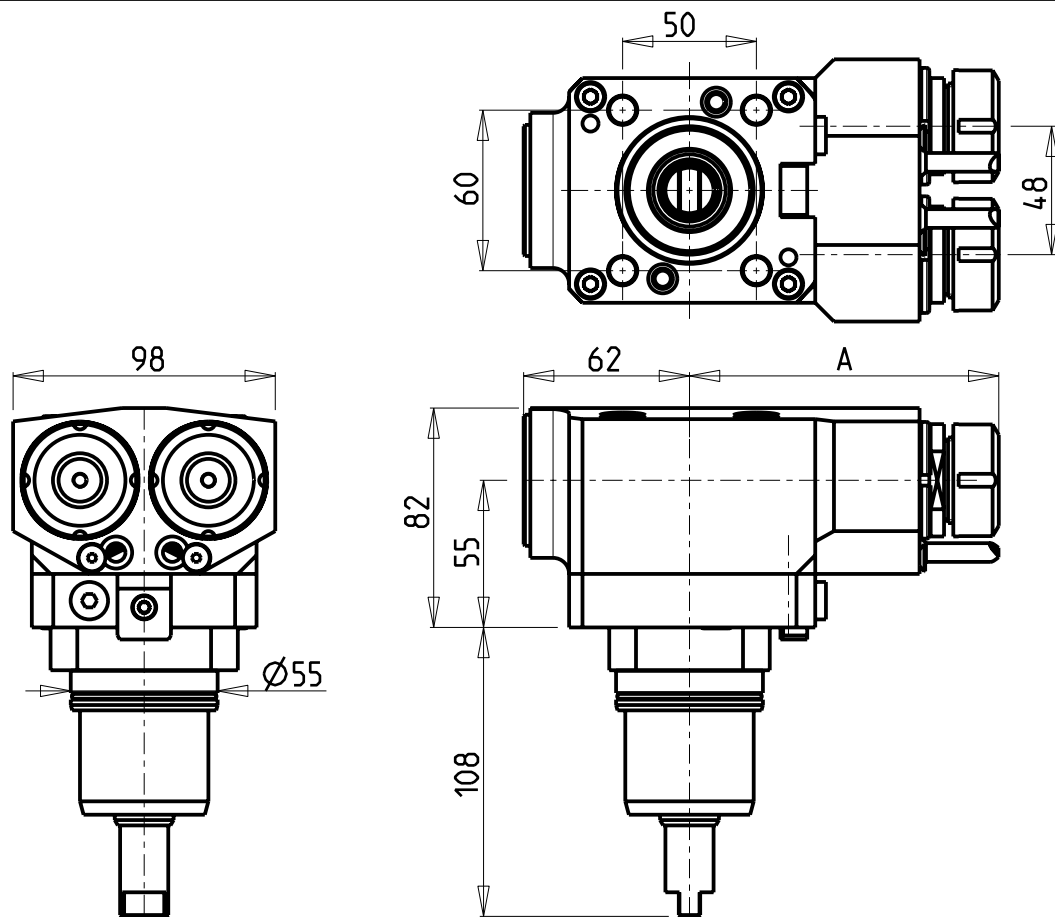

ATTENZIONE - ATTENTION - ACHTUNG

- Per lo smontaggio degli utensili utilizzare sempre la chiave di contrasto come indicato nel manuale d'uso.
- For disassembly of the tools use always the contrast key as mentioned in the user instructions.
- Fuer das Abmontieren der Werkzeuge immer den Gegenschlüssel benutzen wie in der Bedienungsanleitung erwahnt.

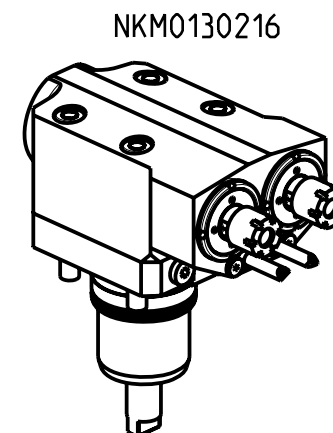
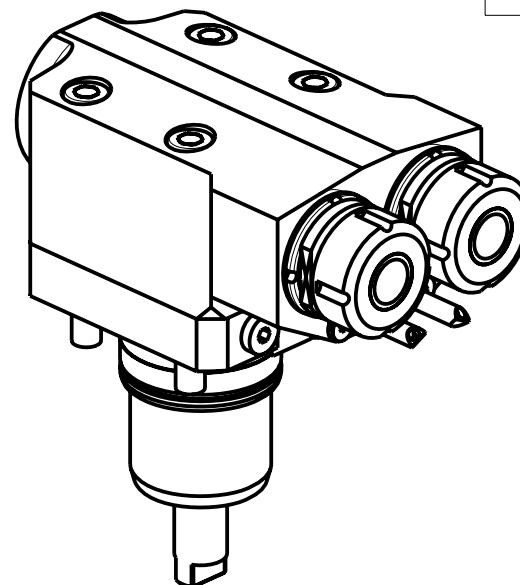

Cod. MT	Mandrino Spindle Spindel	I	RPM	Coppia Max Max Torque Max Drehmoment	Reversibile lato mandrino/contromandrino Reversible sub/main spindle side Umkehrbare Spindel-seite/ Gegenspindel-seite	Lubrificazione est. Ext. coolant Aussehenkuehlung	A	CHIAVI NON INCLUSE Keys not included Schluesssel nicht einbegriffen	
								CHUB17	CHMNER16
NKM0130216	ER 16	1:1	6000	30Nm	X	X	115.15	CHUB17	CHMNER16
NKM0130225	ER 25	1:1	6000	30Nm	X	X	115.61	MNL0210007	CHSTER25

NAKAMURA-TOME

WT150/250 - WT15011/25011 - WTW150 - WTS150 - SUPER NTM3 - SUPER NTJ - SUPER NTJX - SC200/250
 NTY3 250 - TW10M/MY/MM/MMY/MMYY-TW20M/MY/MM/MMY/MMYY 16 ST.

MODULO MOTORIZZATO ASSIALE 2 USCITE IN Y H=55mm

Axial single side twin head driven tool in Y H=55mm

Axial angetriebenes Werkzeug 2 Ausgaenge in Y H=55mm

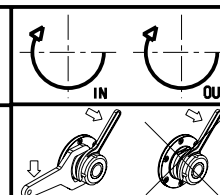

M.T. srl

Via Casino Albini 480
 Tel. 0541/956034-957884
 Fax 0541/956341

47842 S. GIOVANNI IN M. (RN)
 e-mail: mtma@mtmarchetti.com
 http://www.mtmarchetti.com

PRODUZIONE MODULI ROTANTI



PAGINA NKM260-2-10

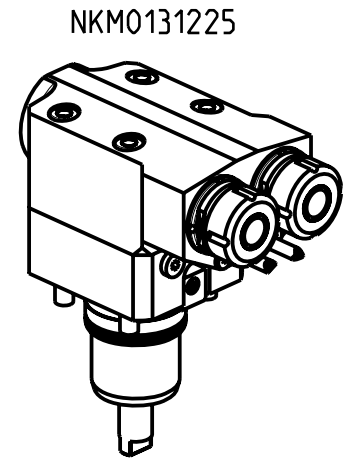
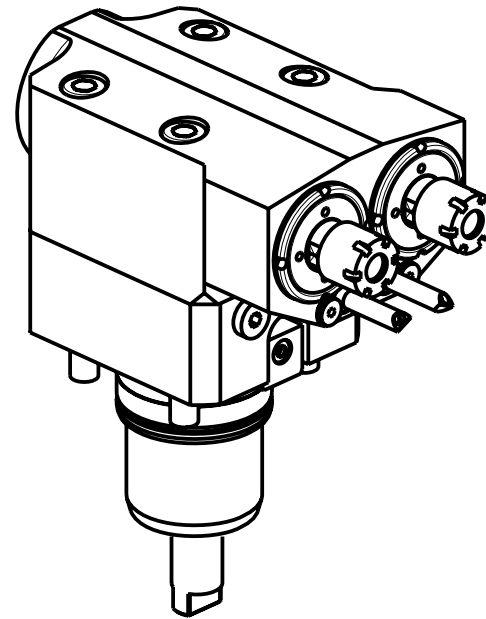
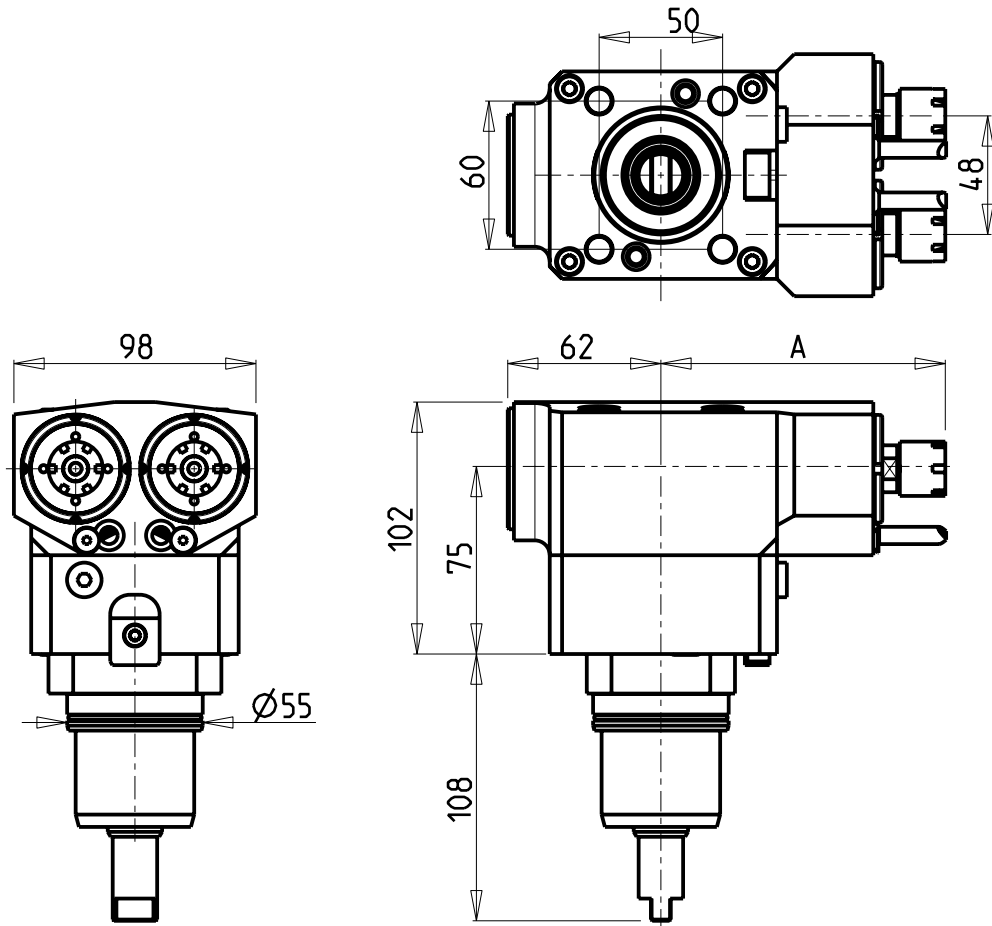

ATTENZIONE - ATTENTION - ACHTUNG

- Per lo smontaggio degli utensili utilizzare sempre la chiave di contrasto come indicato nel manuale d'uso.
- For disassembly of the tools use always the contrast key as mentioned in the user instructions.
- Fuer das Abmontieren der Werkzeuge immer den Gegenschlüssel benutzen wie in der Bedienungsanleitung erwaeht.

Cod. MT	Mandrino Spindle Spindel	I	RPM	Coppia Max Max Torque Max Drehmoment	Reversibile lato mandrino/contromandrino Reversible sub/main spindle side Umkehrbare Spindel-seite/ Gegenspindel-seite	Lubrificazione est. Ext. coolant Ausseukuehlung	A	CHIAVI NON INCLUSE Keys not included Schluessel nicht einbegriffen	
NKM0131216	ER 16	1:1	6000	30Nm	X	X	115.15	CHUB17	CHMNER16
NKM0131225	ER 25	1:1	6000	30Nm	X	X	115.61	MNL0210007	CHSTER25

NAKAMURA-TOME

WT250 - WT15011/25011 - WTW150 - WTS150 - SC200/250 - SUPER NTJX - NTY3 250

MODULO MOTORIZZATO ASSIALE 2 USCITE IN Y H=75mm

Axial single side twin head driven tool in Y H=75mm

Axial angetriebenes Werkzeug 2 Ausgaenge in Y H=75mm

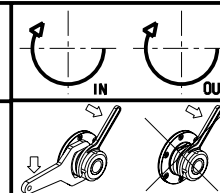

M.T. srl

Via Casino Albini 480
Tel. 0541/956034-957884

Fax 0541/956341

47842 S. GIOVANNI IN M. (RN)

e-mail: mtma@mtmarchetti.com

http://www.mtmarchetti.com

PRODUZIONE MODULI ROTANTI



PAGINA NKM260-2-20

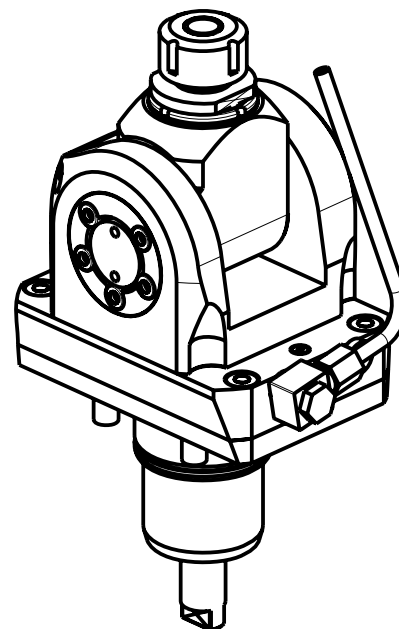
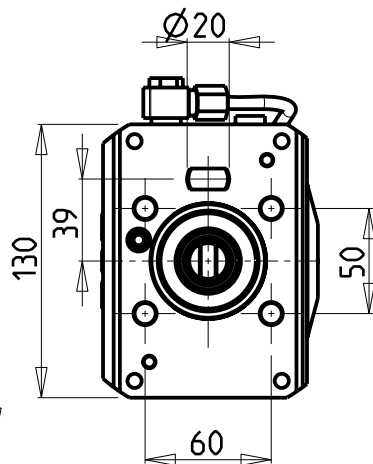
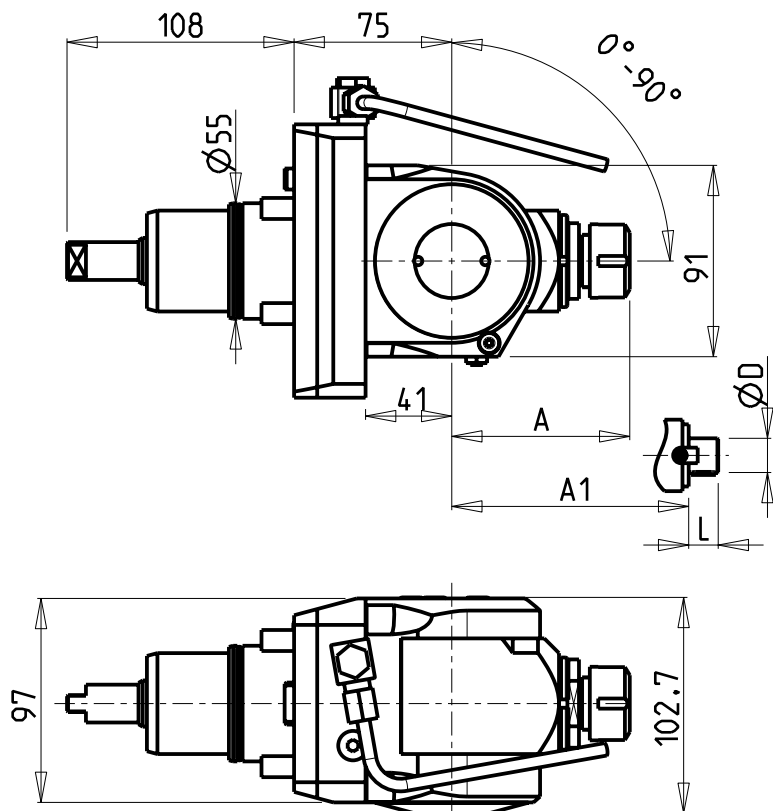

ATTENZIONE - ATTENTION - ACHTUNG

- Per lo smontaggio degli utensili utilizzare sempre la chiave di contrasto come indicato nel manuale d'uso.
- For disassembly of the tools use always the contrast key as mentioned in the user instructions.
- Fuer das Abmontieren der Werkzeuge immer den Gegenschlüssel benutzen wie in der Bedienungsanleitung erwäohnt.

ATTENZIONE - ATTENTION - ACHTUNG

- Verificare la tabella sottostante per possibile interferenza su alcuni modelli di macchine
- Please check the table below for possible interferences on some machine models
- Die untenstehende tabelle unbedingt auf eventuelle interferenzen auf einigen maschinen modellen überprüfen

Cod. MT	Mandrino Spindle Spindel	I	RPM	Coppia Max Max Torque Max Drehmoment	Reversibile lato mandrino/contromandrino Reversible sub/main spindle side Umkehrbare Spindel-seite/ Gegenspindel-seite	Lubrificazione est. Ext. coolant Aussehenkuehlung	A	A1	D	L	CHIAVI INCLUSE Keys included Schluessel inbegriffen			
NKM0090020	ER20	1:1	6000	40Nm	X	X	84.16	-	-	-	CHSTER20	CHUB36	CHESL06	CHESL07
NKM0090025	ER25	1:1	6000	40Nm	X	X	85.66	-	-	-	CHSTER25	CHUB36	CHESL06	CHESL07
NKM0091617	Ø16x17	1:1	6000	40Nm	X	X	-	65	16	17	CH_VTCROCE_M08	CHUB36	CHESL06	CHESL07
NKM0092219	Ø22x19	1:1	6000	40Nm	X	X	-	66	22	19	CH_VTCROCE_M10	CHUB36	CHESL06	CHESL07
NKM0091905	Ø3/4"x3/4"	1:1	6000	40Nm	X	X	-	65	3/4"	3/4"	CH_VTCROCE_M08	CHUB36	CHESL06	CHESL07

NAKAMURA-TOME

WT150/250 - WT15011/25011 - WTW150 - WTS150 - SUPER NTM3 - SUPER NTJ - SUPER NTJX - SC200/250
 NTY3_250 - TW10M/MY/MM/MMY/MYY-TW20M/MY/MM/MMY/MYY 16 ST.

MODULO MOTORIZZATO ORIENTABILE 0-90°

0-90° adjustable angle driven tool

Angetriebenes Werkzeug schwenkbar 0-90°

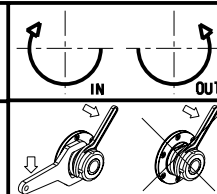

M.T. srl

Via Casino Albini 480
 Tel. 0541/956034-957884
 Fax 0541/956341

47842 S. GIOVANNI IN M. (RN)
 e-mail: mtma@mtmarchetti.com
 http://www.mtmarchetti.com

PRODUZIONE MODULI ROTANTI



PAGINA NKM330-2-00

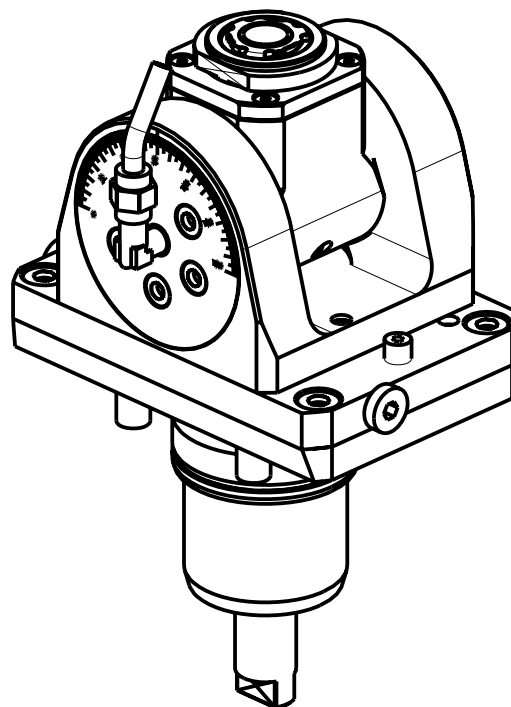
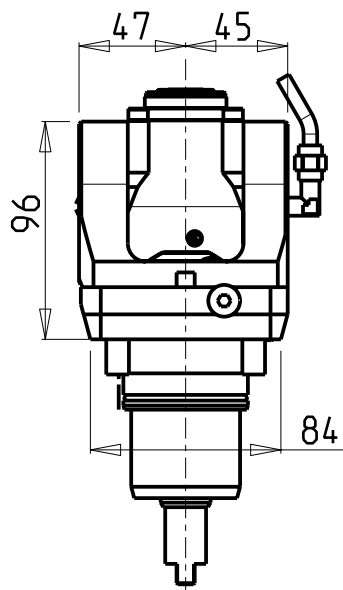
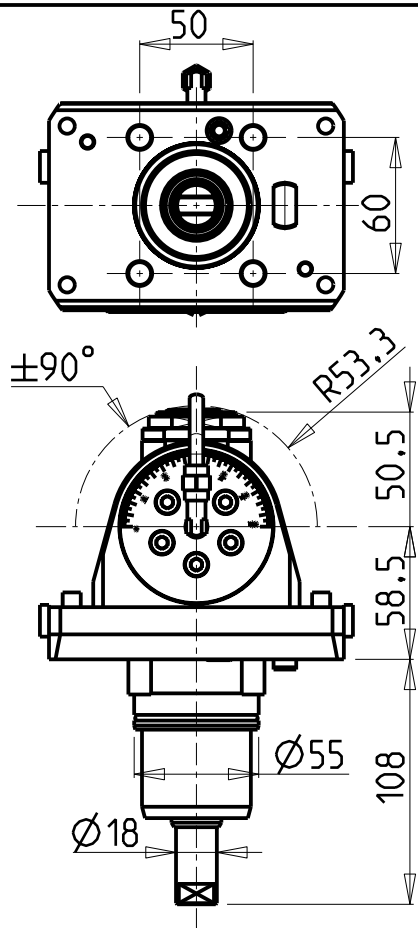

ATTENZIONE - ATTENTION - ACHTUNG

- Per lo smontaggio degli utensili utilizzare sempre la chiave di contrasto come indicato nel manuale d'uso.
- For disassembly of the tools use always the contrast key as mentioned in the user instructions.
- Fuer das Abmontieren der Werkzeuge immer den Gegenschlüssel benutzen wie in der Bedienungsanleitung erwäehnt.

ATTENZIONE - ATTENTION - ACHTUNG

- Verificare la tabella sottostante per possibile interferenza su alcuni modelli di macchine
- Please check the table below for possible interferences on some machine models
- Die untenstehende tabelle unbedingt auf eventuelle interferenzen auf einigen maschinen modellen überprüfen

Cod. MT	Mandrino Spindle Spindel	i	RPM	Coppia Max Max Torque Max Drehmoment	Lubr.interna Coolant through Innenkuehlung	Lubrificazione est. Ext. coolant Aussenkuehlung	CHIAVI INCLUSE Keys included Schluessel inbegriffen					
							CHUB22	CHUB36	CHESL05	CHESL07	CHTAER20ZC	
NKM0790120	ERA20	1:1	6000	30Nm		X	CHUB22	CHUB36	CHESL05	CHESL07	CHTAER20ZC	NEW
NKM0790220	ERA20	1:1	6000	30Nm	P=70bar	X	CHUB22	CHUB36	CHESL05	CHESL07	CHTAER20ZC	NEW

NAKAMURA-TOME

WT150/250 - WT15011/25011 - WTW150 - WTS150 - SUPER NTM3 - SUPER NTJ - SUPER NTJX - SC200/250
 NTY3 250 - TW10M/MY/MM/MMY/MMYY-TW20M/MY/MM/MMY/MMYY 16 ST.

MODULO MOTORIZZATO ORIENTABILE ±90°

±90° adjustable angle driven tool

Angetriebenes Werkzeug schwenkbar ±90°

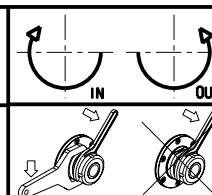

M.T. srl

Via Casino Albini 480
 Tel. 0541/956034-957884
 Fax 0541/956341

47842 S. GIOVANNI IN M. (RN)
 e-mail: mtma@mtmarchetti.com
 http://www.mtmarchetti.com

PRODUZIONE MODULI ROTANTI



PAGINA NKM335-2-00

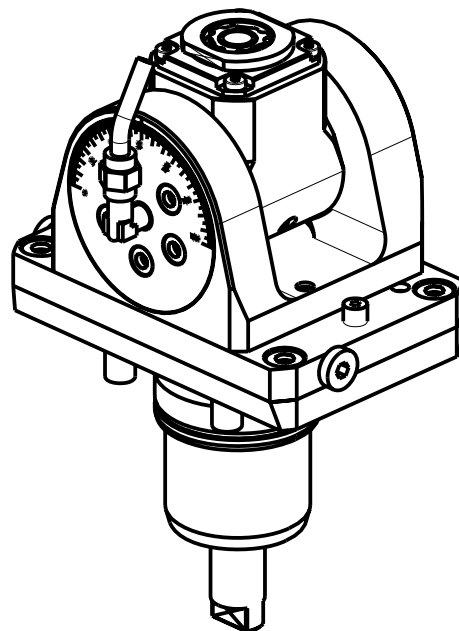
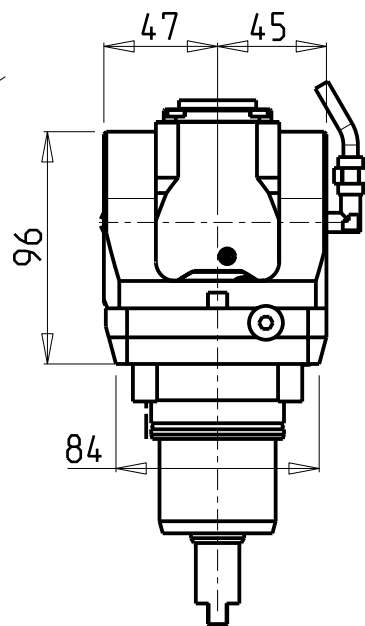
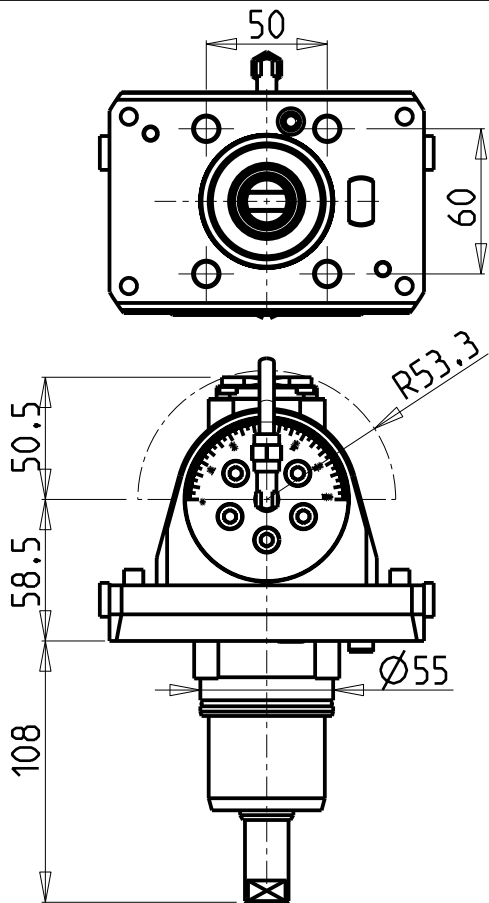

ATTENZIONE - ATTENTION - ACHTUNG

- Per lo smontaggio degli utensili utilizzare sempre la chiave di contrasto come indicato nel manuale d'uso.
- For disassembly of the tools use always the contrast key as mentioned in the user instructions.
- Fuer das Abmontieren der Werkzeuge immer den Gegenschlüssel benutzen wie in der Bedienungsanleitung erwäohnt.

ATTENZIONE - ATTENTION - ACHTUNG

- Verificare la tabella sottostante per possibile interferenza su alcuni modelli di macchine
- Please check the table below for possible interferences on some machine models
- Die untenstehende tabelle unbedingt auf eventuelle interferenzen auf einigen maschinen modellen überprüfen

Cod. MT	Mandrino Spindle Spindel	I	RPM	Coppia Max Max Torque Max Drehmoment	Lubr.interna Coolant through Innenkuehlung	Lubrificazione est. Ext. coolant Aussenkuehlung	CHIAVI INCLUSE Keys included Schluessel inbegriffen					
							CHUB19_SP3	CHUB32	CHESL05	CHESL07	CHTAER16ZC	
NKM0790316	ERA16	1:2	12000	8Nm		X	CHUB19_SP3	CHUB32	CHESL05	CHESL07	CHTAER16ZC	NEW
NKM0790416	ERA16	1:2	12000	8Nm	P=70bar	X	CHUB19_SP3	CHUB32	CHESL05	CHESL07	CHTAER16ZC	NEW

NAKAMURA-TOME

WT150/250 - WT15011/25011 - WTW150 - WTS150 - SUPER NTM3 - SUPER NTJ - SUPER NTJX - SC200/250
 NTY3 250 - TW10M/MY/MM/MYY/MYY-TW20M/MY/MM/MYY/MYY 16 ST.

MODULO MOTORIZZATO ORIENTABILE +/-90° MOLTIPLICATO I=1:2

+/-90° adjustable angle driven tool geared-up I=1:2

Angetriebenes Werkzeug schwenkbar +/-90° uebersetzt I=1:2

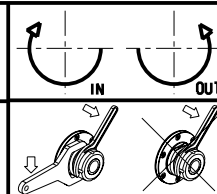

M.T. srl

Via Casino Albini 480
 Tel. 0541/956034-957884
 Fax 0541/956341

47842 S. GIOVANNI IN M. (RN)
 e-mail: mtma@mtmarchetti.com
 http://www.mtmarchetti.com

PRODUZIONE MODULI ROTANTI



PAGINA NKM336-2-00

ATTENZIONE - ATTENTION - ACHTUNG

- Verificare la tabella sottostante per possibile interferenza su alcuni modelli di macchine
- Please check the table below for possible interferences on some machine models
- Die untenstehende tabelle unbedingt auf eventuelle interferenzen auf eingen maschinen modellen überprüfen

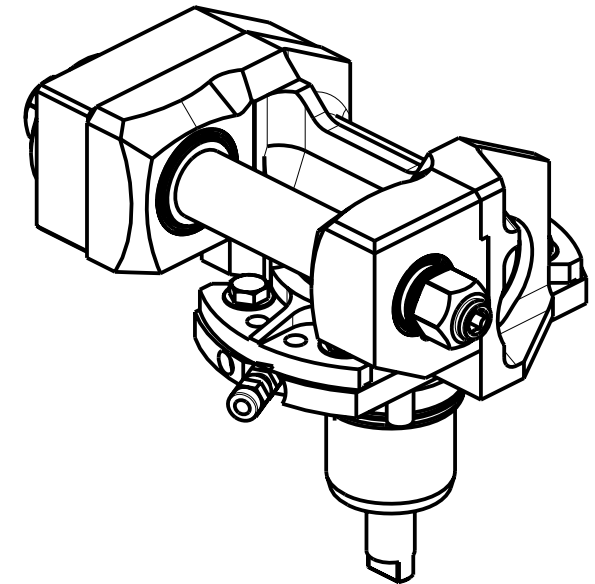
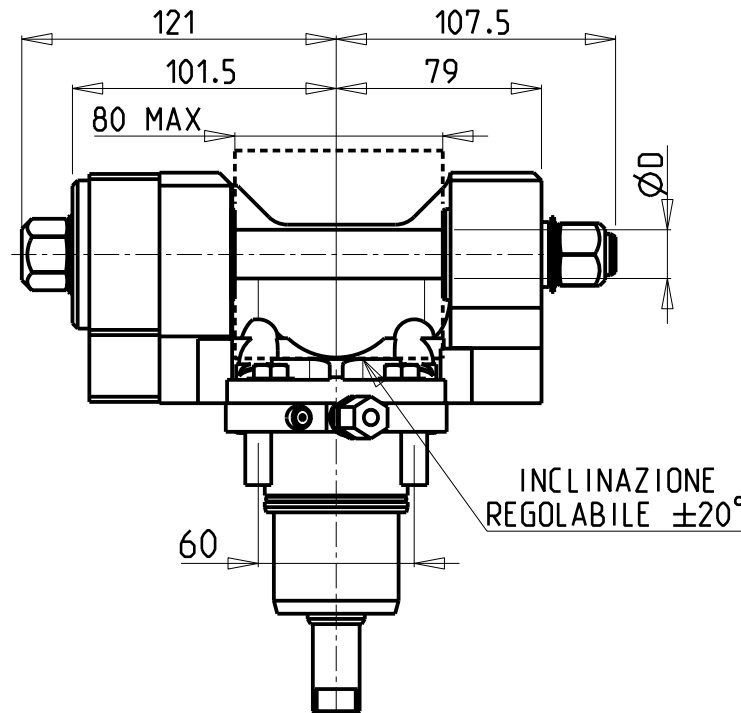
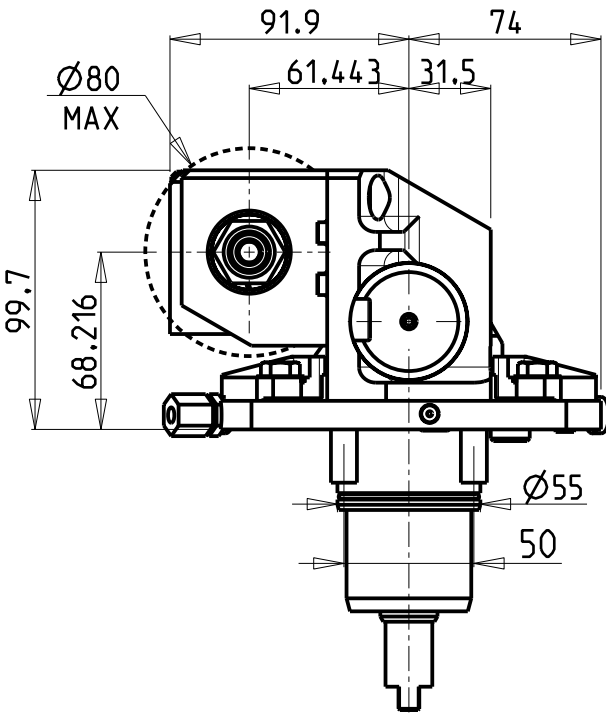

DOTAZIONI - SUPPLIED WITH - AUSSTATTUNG

- | | |
|-----------|---|
| mm / inch | - N°1 ALBERO + DISTANZIALI
- N°1 SHAFT + SPACER
- N°1 DORN + ABSTANDSSTUECK |
|-----------|---|

PER ALBERI E DISTANZIALI VEDI PAG. TBL250-1-00
FOR SHAFT END SPACER SEE PAGE TBL250-1-00
FUER DORN UND ABSTANDSSTUECK SEITE TBL250-1-00

Cod. MT	I	RPM MAX	Coppia Max Max Torque Max Drehmoment	Reversibile lato mandrino/contromandrino Reversible sub/main spindle side Umkehrbare Spindel-seite/ Gegenspindel-seite	Lubrificazione est. Ext. coolant Aussenkuehlung	D (mm)	D (Inch)	CHIAVI INCLUSE Keys included Schluessel inbegriffen			
								CHUB13	CHUB24	CHESL08	CHESL07
NKM0081100	1:1	6000	60Nm	X	X	16-22-27-32	3/4"-1"-1 1/4"	CHUB13	CHUB24	CHESL08	CHESL07
NKM0082100	2:1	3000	80Nm	X	X	16-22-27-32	3/4"-1"-1 1/4"	CHUB13	CHUB24	CHESL08	CHESL07

NAKAMURA-TOME

WT150/250 - WT150II/250II - WTW150 - WTS150 - SUPER NTM3 - SUPER NTJ - SUPER NTJX - SC200/250
NTY3_250 - TW10M/MY/MM/MMY/MMYY-TW20M/MY/MM/MMY/MMYY 16 ST.

MODULO MOTORIZZATO PORTACREATORE

Driven gear hobber

Angetriebenes Zahnradwalzfraes-Werkzeug

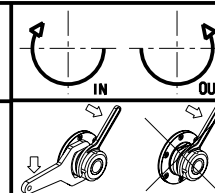

M.T. srl

Via Casino Albini 480
Tel. 0541/956034-957884
Fax 0541/956341
47842 S. GIOVANNI IN M. (RN)
e-mail: mtma@mtmarchetti.com
http://www.mtmarchetti.com

PRODUZIONE MODULI ROTANTI



PAGINA NKM340-2-00

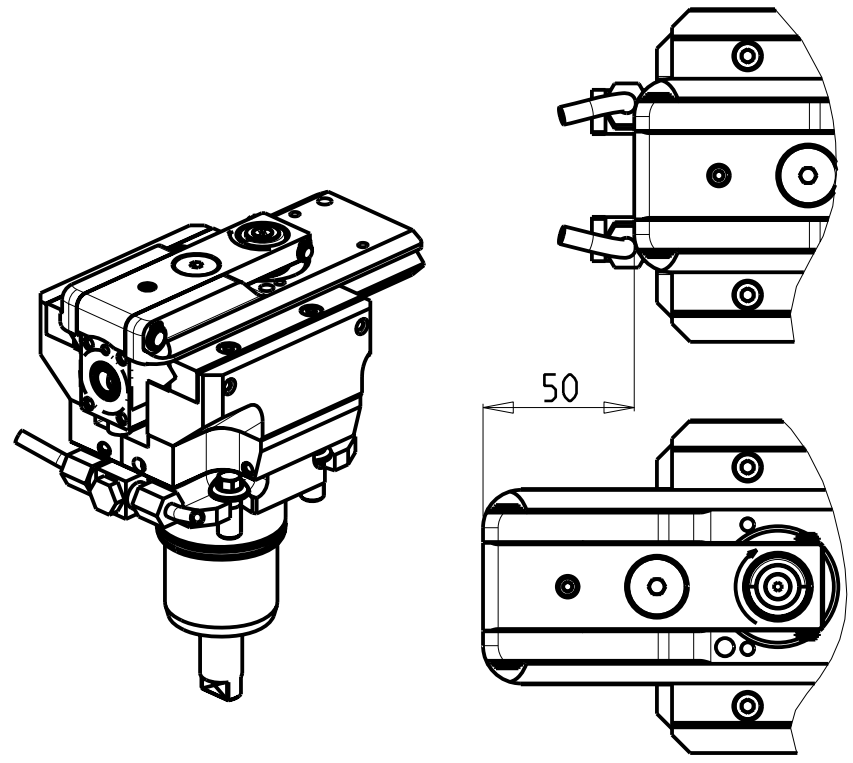
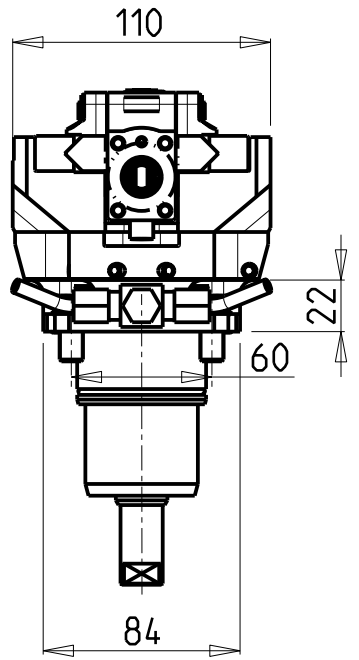
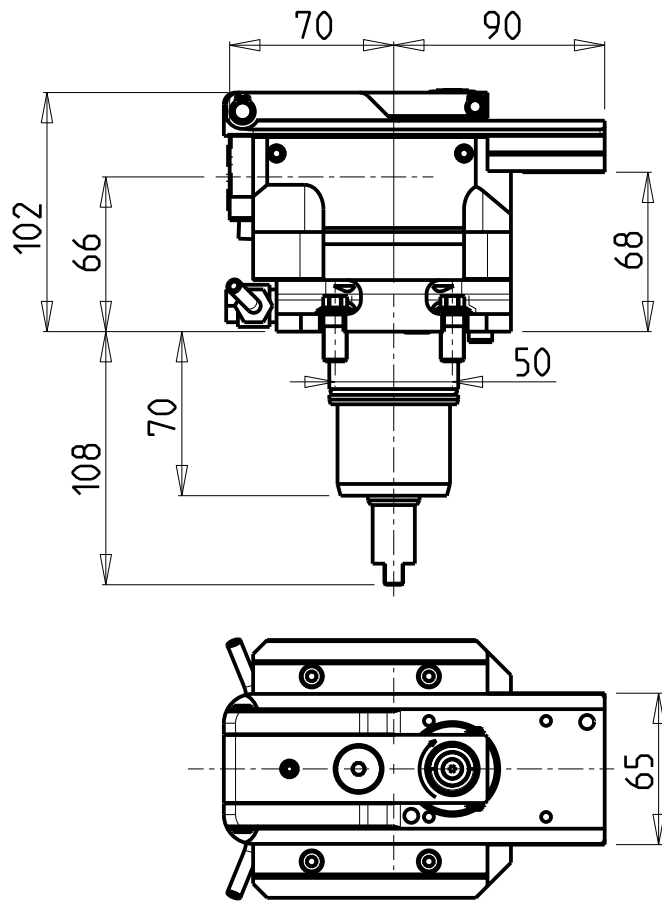

Cod. MT	I	RPM MAX	Reversibile lato mandrino/contromandrino Reversible sub/main spindle side Umkehrbare Spindel-seite/ Gegenspindel-seite	Lubr. esterna Ext. coolant Aussenkuehlung
NKM0910100	4:1	2000	X	X

NEW

PER UTENSILI STOZZATORI VEDI PAG. TBL400-1-00
 FOR DRIVEN SLOTTING TOOL CUTTING-TOOLS SEE PAGE TBL400-1-00
 FÜR NUTENSTOSS-WERKZEUG SCHNEIDWERKZEUGE SIEHE SEITE TBL400-1-00

NAKAMURA-TOME

WT150 - SUPER NTJ - SUPER NTM3

MODULO MOTORIZZATO STOZZATORE H=66mm

Slotting driven tool H=66mm

Keilnutenstossmaschine H=66mm

M.T. srl

Via Casino Albini 480
 Tel. 0541/956034-957884
 Fax 0541/956341
 47842 S. GIOVANNI IN M. (RN)
 e-mail: mtma@mtmarchetti.com
 http://www.mtmarchetti.com

PRODUZIONE MODULI ROTANTI



PAGINA NKM360-2-00

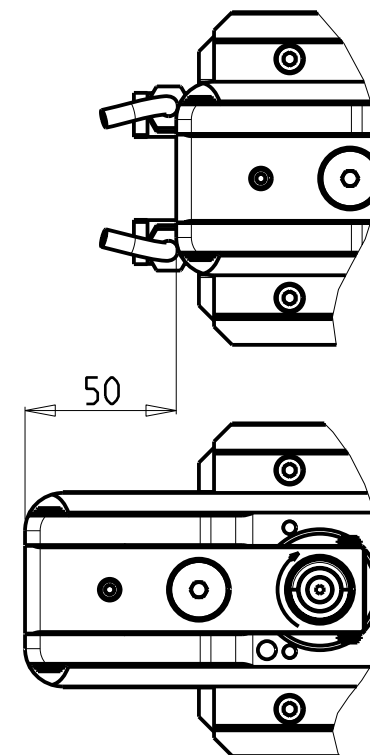
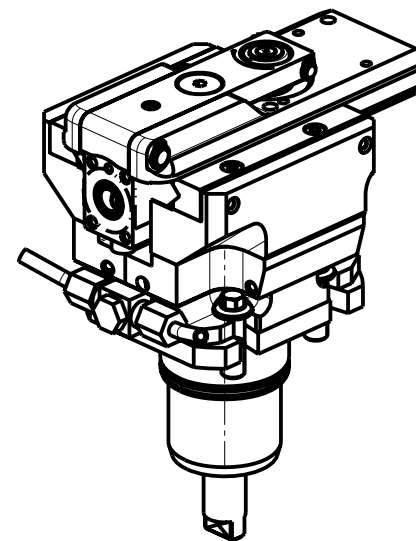
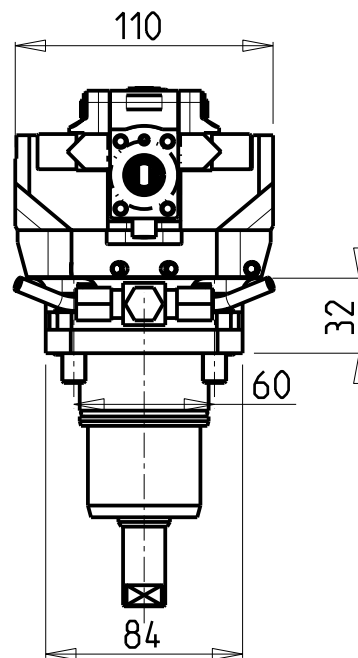
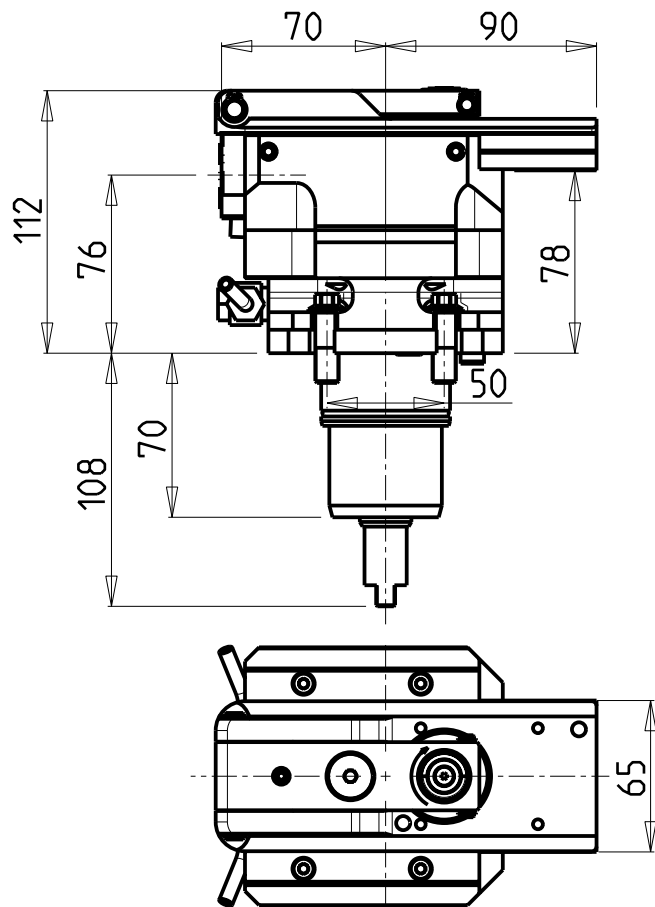

Cod. MT	I	RPM MAX	Reversibile lato mandrino/contromandrino Reversible sub/main spindle side Umkehrbare Spindel-seite/ Gegenspindel-seite	Lubr. esterna Ext. coolant Aussenkuehlung
NKM0920100	4:1	2000	X	X

NEW

PER UTENSILI STOZZATORI VEDI PAG. TBL400-1-00
 FOR DRIVEN SLOTTING TOOL CUTTING-TOOLS SEE PAGE TBL400-1-00
 FÜR NUTENSTOSS-WERKZEUG SCHNEIDWERKZEUGE SIEHE SEITE TBL400-1-00

NAKAMURA-TOME

WT250 - WT150II/250II - WTW150 - WTS150 - SC200 - SC250 - SUPER NTJX - NTY3 250

MODULO MOTORIZZATO STOZZATORE H=76mm

Slotting driven tool H=76mm

Keilnutenstossmaschine H=76mm

M.T. srl

Via Casino Albini 480
 Tel. 0541/956034-957884
 Fax 0541/956341
 47842 S. GIOVANNI IN M. (RN)
 e-mail: mtma@mtmarchetti.com
 http://www.mtmarchetti.com

PRODUZIONE MODULI ROTANTI



PAGINA NKM360-2-10

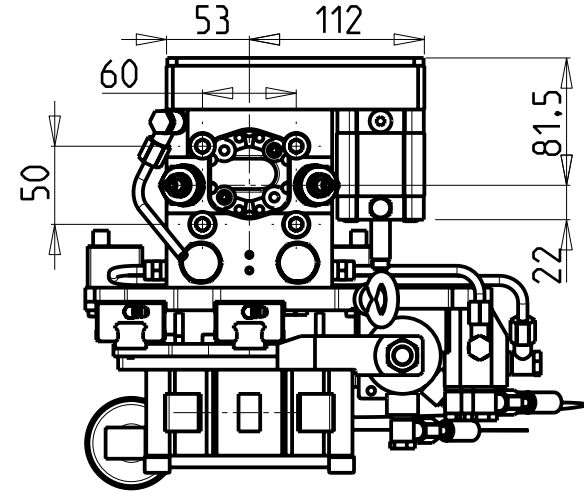
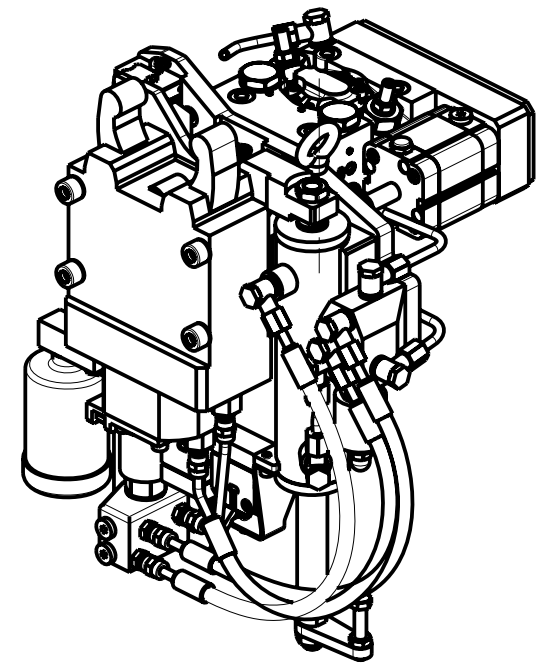
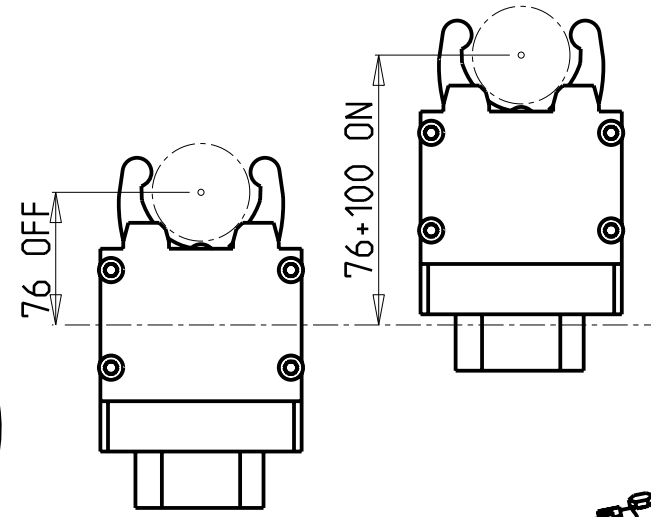
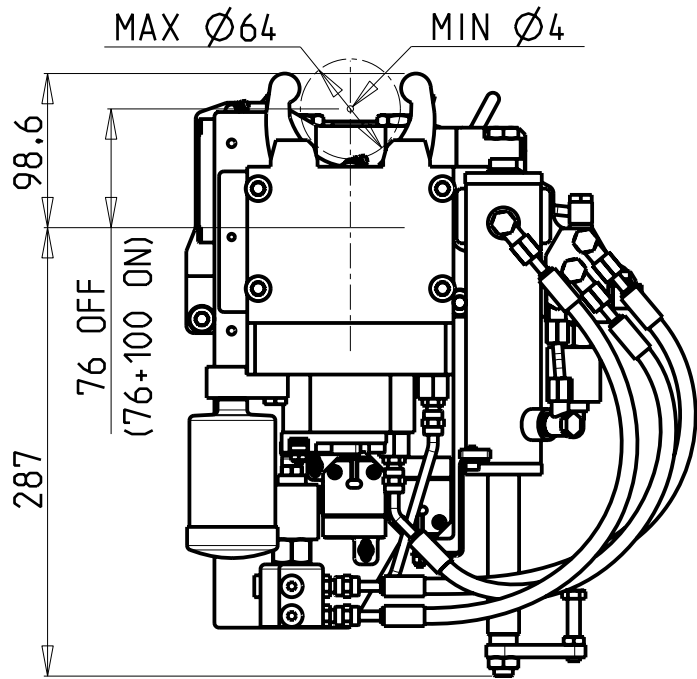
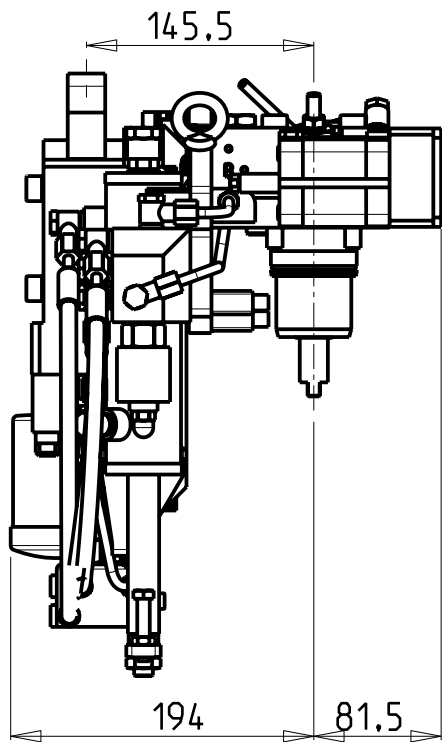

- #  CON GESTIONE ELETTRONICA APERTURA COMPLETA DELLA LUNETTA
- # With Electronic control of steady rest arms complete opening
- # Mit vollstaendiger elektronischer Oeffnungsbedienung der Luenette

Cod. MT	I	RPM	Lubr.esterna Ext. coolant Aussenkuehlung	
NKM0760300	1:1	6000	X	NEW
# NKM0760300A	1:1	6000	X	NEW

NAKAMURA-TOME
 WT150/250 - WT15011/25011 - WTW150 - WTS150 - SUPER NTM3 - SUPER NTJ - SUPER NTJX - NTY3 250

MODULO MOTORIZZATO PER LUNETTA RETRATTILE (TAGLIA 1)
 Driven toolholder for sliding steady rest (Size 1)
 Luenettenwerkzeug zurueck versetzte Version (Grossse 1)

M.T. srl
 Via Casino Albini 480
 Tel. 0541/956034-957884
 Fax 0541/956341
 47842 S. GIOVANNI IN M. (RN)
 e-mail: mtma@mtmarchetti.com
 http://www.mtmarchetti.com

PRODUZIONE MODULI ROTANTI



PAGINA NKM363-2-00

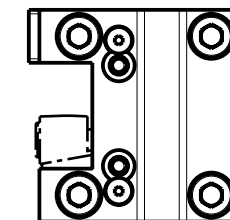
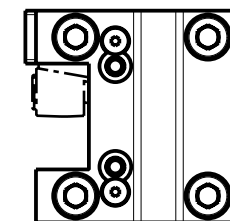
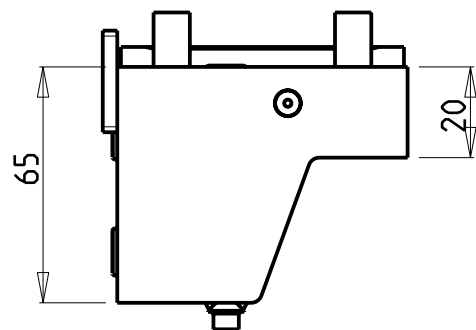
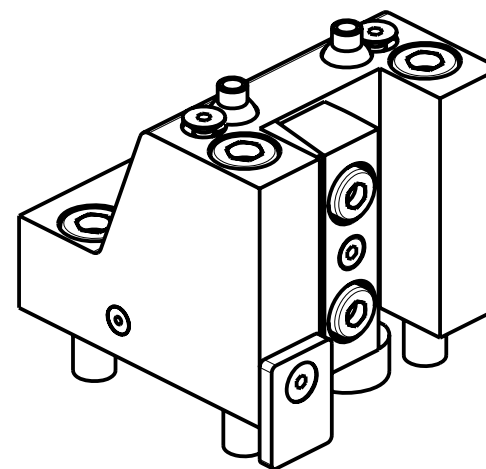
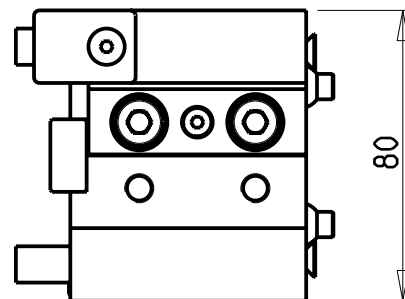
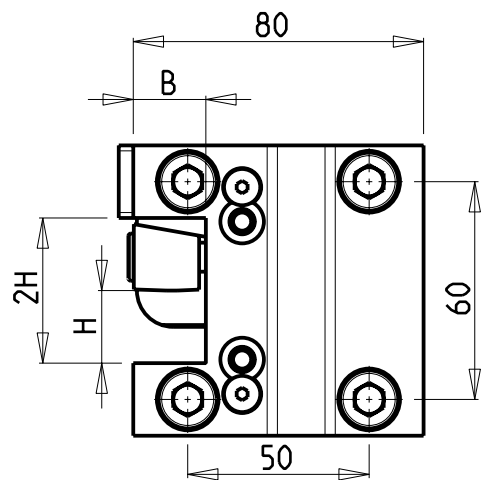

Cod. MT	Cod. NAKAMURA	N°Utensili N° Tools N° Werkzeuge	Reversibile lato mandrino/contromandrino Reversible sub/main spindle side Umkehrbare Spindel-seite/ Gegenspindel-seite	Misure Dimensions Masse	B	H
NKM0162000	W 14 31/W 14 32	1	X	mm	20	20
NKM0161905	W 14 41/W 14 42	1	X	Inch	3/4"	3/4"

NAKAMURA-TOME

WT150/250 - WT15011/25011 - WTW150 - WTS150 - SUPER NTM3 - SUPER NTJ - SUPER NTJX - SC200/250
 NTY3 250 - TW10M/MY/MM/MMY/MMYY-TW20M/MY/MM/MMY/MMYY 16 ST.

PORTAUTENSILE RADIALE SINGOLO

Radial single static tool

Radial Single-Werkzeughalter

M.T. srl

Via Casino Albini 480
 Tel. 0541/956034-957884
 Fax 0541/956341
 47842 S. GIOVANNI IN M. (RN)
 e-mail: mtma@mtmarchetti.com
 http://www.mtmarchetti.com

PRODUZIONE MODULI ROTANTI



PAGINA NKM420-2-00

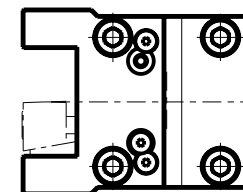
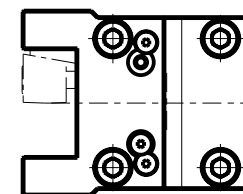
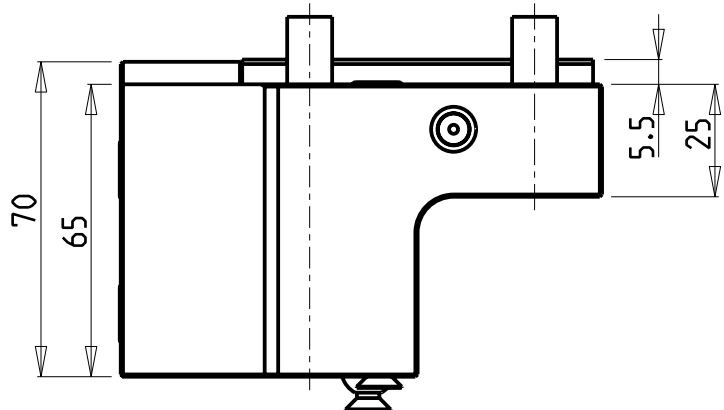
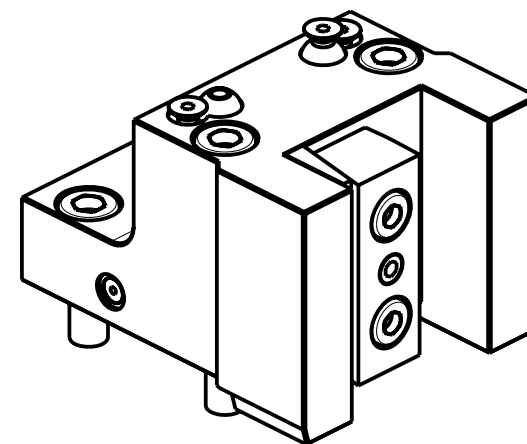
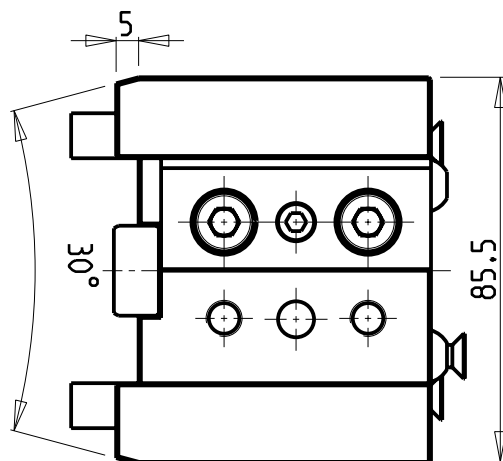
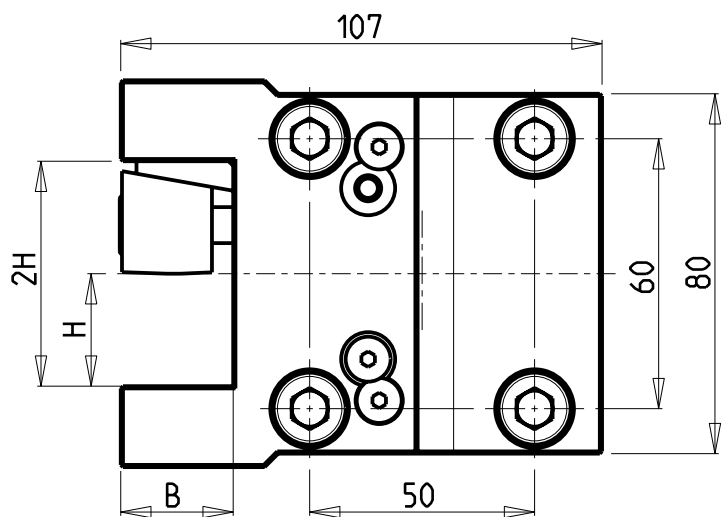

Cod. MT	N°Utensili N°Tools N°Werkzeuge	Reversibile lato mandrino/contromandrino Reversible sub/main spindle side Umkehrbare Spindelseite/ Gegenspindelseite	B	H
NKM0162500	1	X	25	25

NAKAMURA-TOME

WT150/250 - WT15011/25011 - WTW150 - WTS150 - SUPER NTM3 - SUPER NTJ - SUPER NTJX - SC200/250
 NTY3_250 - TW10M/MY/MM/MMY/MMYY-TW20M/MY/MM/MMY/MMYY 16 ST.

PORTAUTENSILE RADIALE SINGOLO

Radial single static tool

Radial Single-Werkzeughalter

M.T. srl

Via Casino Albini 480
 Tel. 0541/956034-957884
 Fax 0541/956341
 47842 S. GIOVANNI IN M. (RN)
 e-mail: mtma@mtmarchetti.com
 http://www.mtmarchetti.com

PRODUZIONE MODULI ROTANTI



PAGINA NKM423-2-00

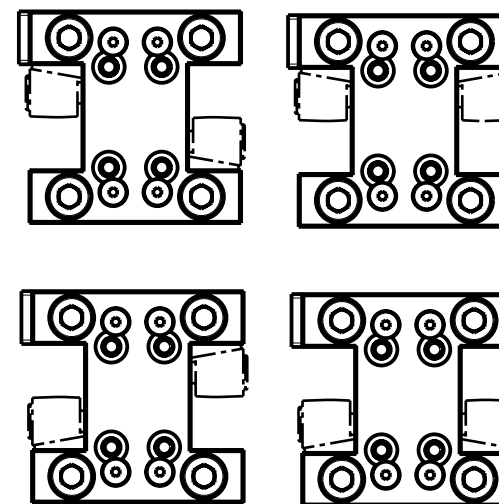
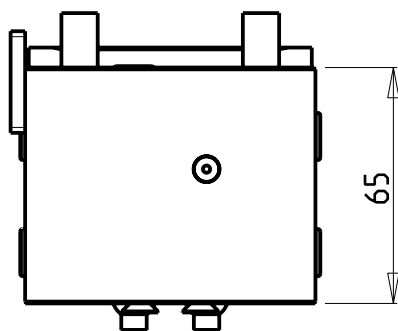
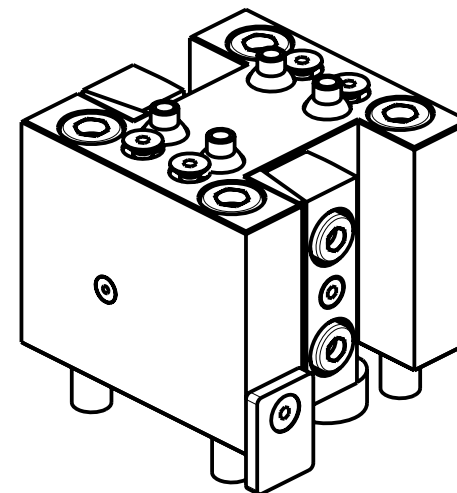
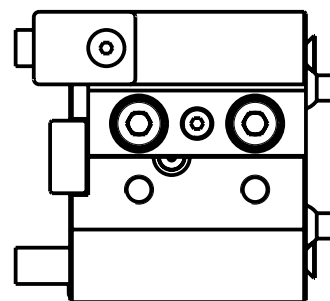
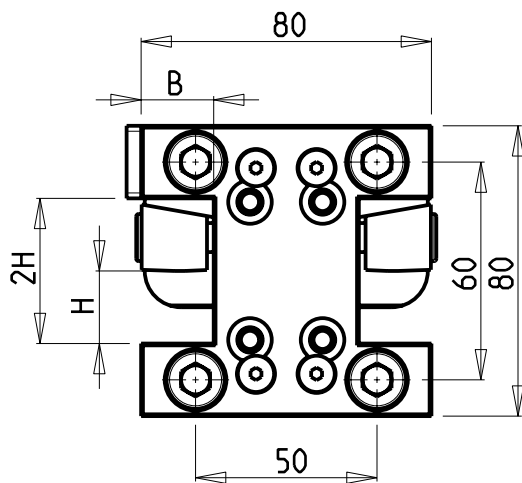

Cod. MT	N°Utensili N°Tools N°Werkzeuge	Reversibile lato mandrino/contromandrino Reversible sub/main spindle side Umkehrbare Spindel-seite/ Gegenspindel-seite	Misure Dimensions Masse	B	H
NKM0152000	2	X	mm	20	20
NKM0151905	2	X	Inch	3/4"	3/4"

NAKAMURA-TOME

WT150/250 - WT15011/25011 - WTW150 - WTS150 - SUPER NTM3 - SUPER NTJ - SUPER NTJX - SC200/250
 NTY3_250 - TW10M/MY/MM/MMY/MMYY-TW20M/MY/MM/MMY/MMYY 16 ST.

PORTAUTENSILE RADIALE DOPPIO

Radial double static tool

Radial Doppel-Werkzeughalter

M.T. srl

Via Casino Albini 480
 Tel. 0541/956034-957884
 Fax 0541/956341
 47842 S. GIOVANNI IN M. (RN)
 e-mail: mtma@mtmarchetti.com
 http://www.mtmarchetti.com

PRODUZIONE MODULI ROTANTI



PAGINA NKM450-2-00

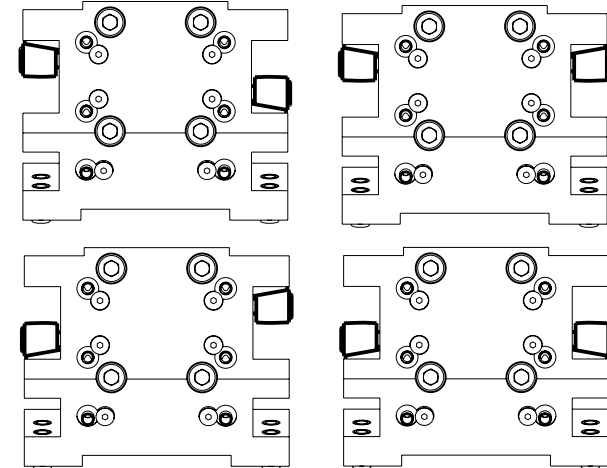
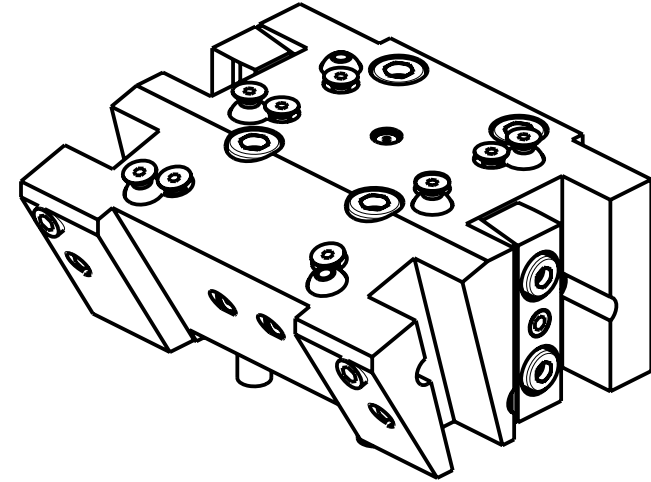
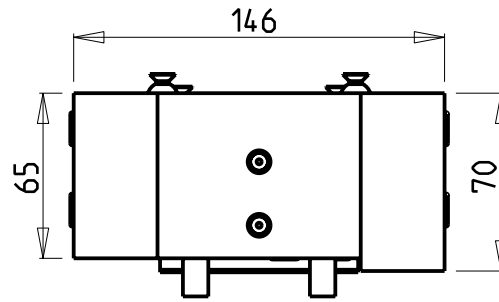
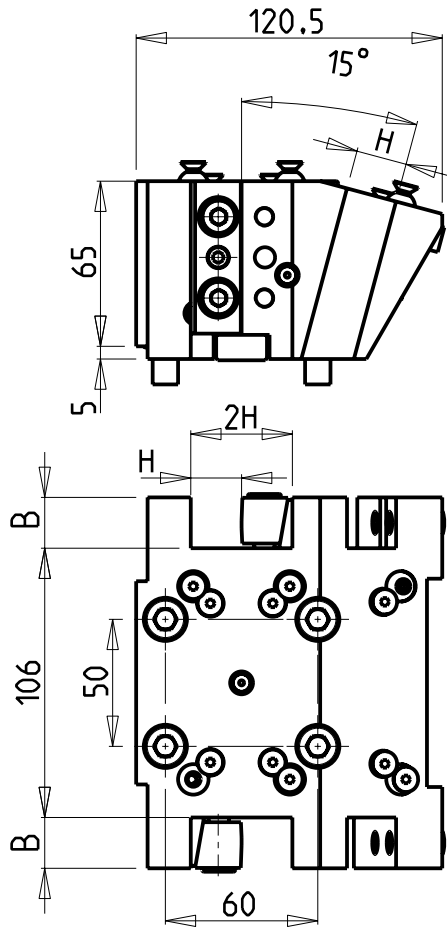

Cod. MT	N°Utensili N° Tools N° Werkzeuge	Reversibile lato mandrino/contromandrino Reversible sub/main spindle side Umkehrbare Spindel-seite/ Gegenspindel-seite	Misure Dimensions Masse	B	H
NKM0221000	4	X	mm	20	20
NKM0221905	4	X	Inch	3/4"	3/4"

NAKAMURA-TOME

MOD: WT150 - WT15011 - SUPER NTM3 - NTY3 250 - SUPER NTJ torretta inferiore/lower turret/unterer revolver

PORTAUTENSILE RADIALE MULTIPLO

Radial multiple static tool

Radial Mehrfach-Halter

M.T. srl

Via Casino Albini 480
Tel. 0541/956034-957884
Fax 0541/956341
47842 S. GIOVANNI IN M. (RN)
e-mail: mtma@mtmarchetti.com
<http://www.mtmarchetti.com>

PRODUZIONE MODULI ROTANTI



PAGINA NKM470-2-00

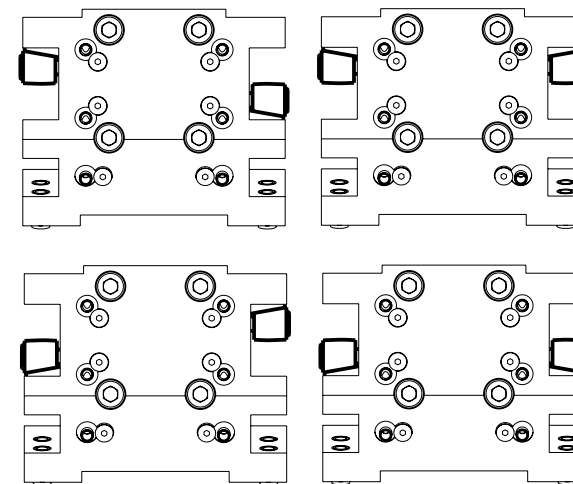
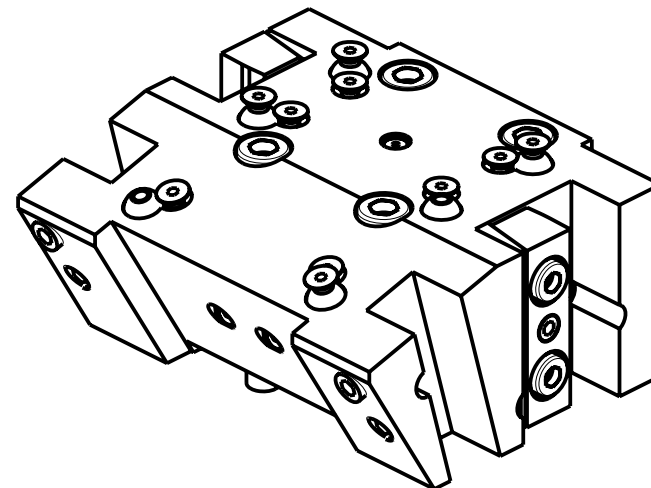
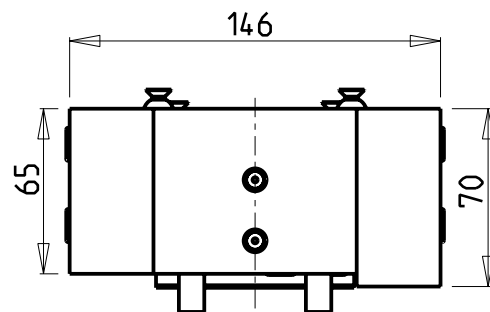
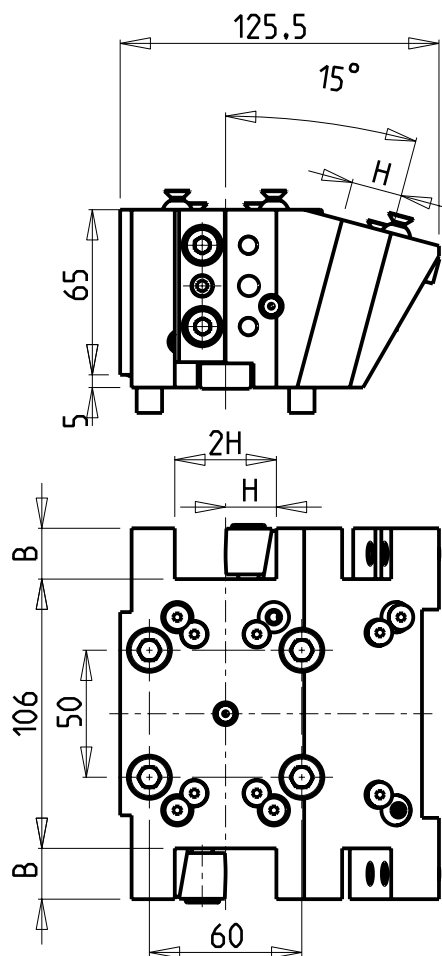

Cod. MT	N°Utensili N°Tools N°Werkzeuge	Reversibile lato mandrino/contromandrino Reversible sub/main spindle side Umkehrbare Spindelseite/ Gegenspindelseite	Misure Dimensions Masse	B	H
NKM0222000	4	X	mm	20	20

NAKAMURA-TOME

MOD: WTW 150 - WTS150 - SUPER NTJX

PORTAUTENSILE RADIALE MULTIPLO

Radial multiple static tool

Radial Mehrfach-Halter

M.T. srl

Via Casino Albini 480
Tel. 0541/956034-957884
Fax 0541/956341
47842 S. GIOVANNI IN M. (RN)
e-mail: mtma@mtmarchetti.com
http://www.mtmarchetti.com

PRODUZIONE MODULI ROTANTI



PAGINA NKM470-2-10

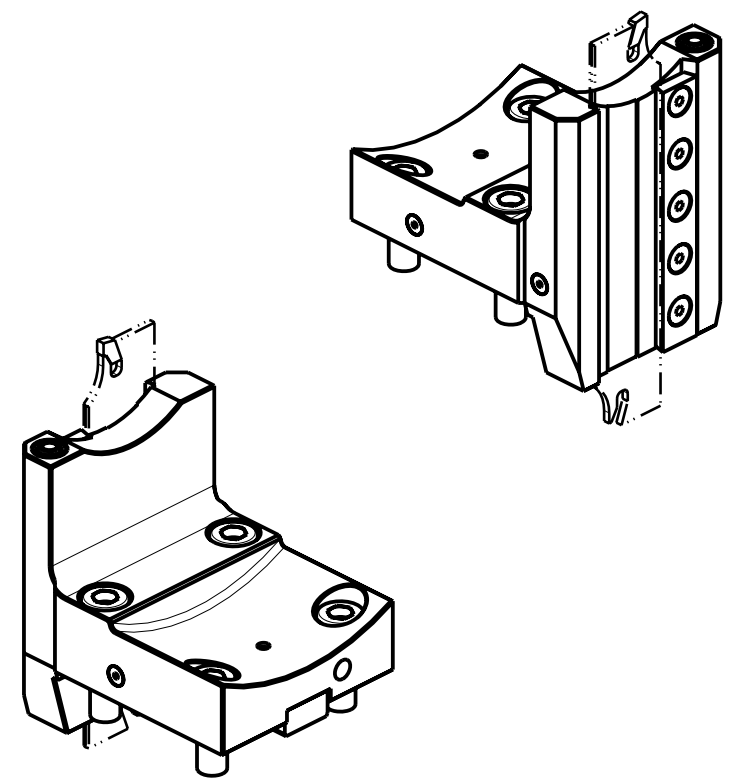
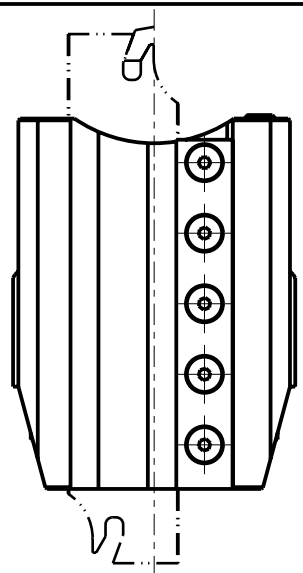
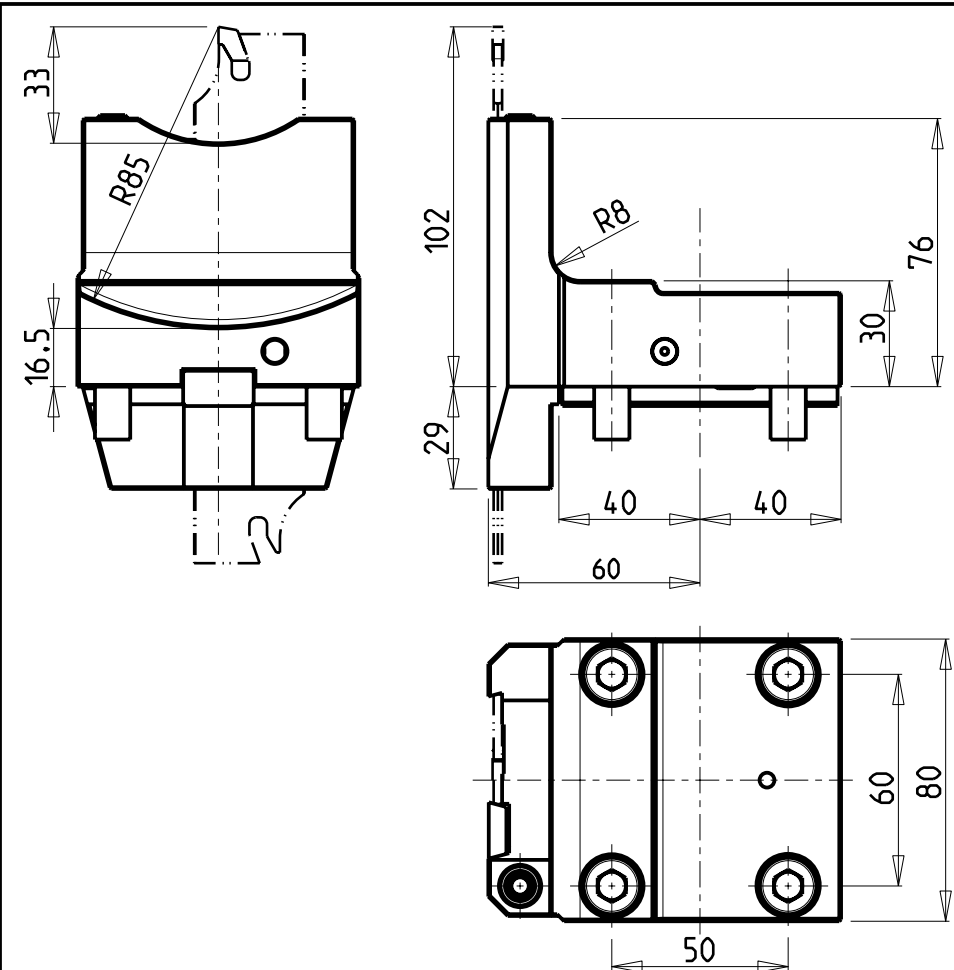

DOTAZIONI - SUPPLIED WITH - AUSSTATTUNG

- N°1 - LAMA - BLADE - KLINGE ISCAR H=32 Sp. 3/4mm (KENNAMETAL OPTIONAL)
- N°10 - INSERTI - INSERTS - EINLAGEN
- N°1 - CHIAVE A T PER MONTAGGIO INSERTI
- T-WRENCH FOR INSERT SET UP
- T-SCHLUESSEL FUER EINSATZSTUECK-MONTAGE

Cod. MT	N°Utensili N°Tools N°Werkzeuge	Reversibile lato mandrino/contromandrino Reversible sub/main spindle side Umkehrbare Spindel-seite/ Gegenspindel-seite
NKM0170132	1	X

NAKAMURA-TOME
 WT150/250 - WT15011/25011 - WTW150 - WTS150 - SUPER NTM3 - SUPER NTJ - SUPER NTJX - SC200/250
 NTY3_250 - TW10M/MY/MM/MYY/MYY-TW20M/MY/MM/MYY/MYY 16 ST.
 PORTAUTENSILE RADIALE PER LAMA
 Radial blade holder
 Radial Abstechhalter

M.T. srl
 Via Casino Albini 480
 Tel. 0541/956034-957884
 Fax 0541/956341
 47842 S. GIOVANNI IN M. (RN)
 e-mail: mtma@mtmarchetti.com
 http://www.mtmarchetti.com

PRODUZIONE MODULI ROTANTI

PAGINA NKM510-2-00

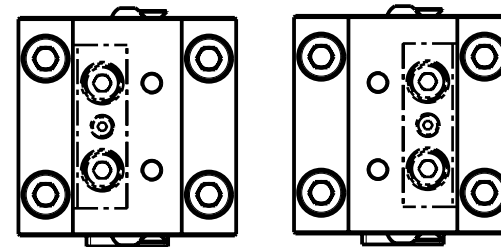
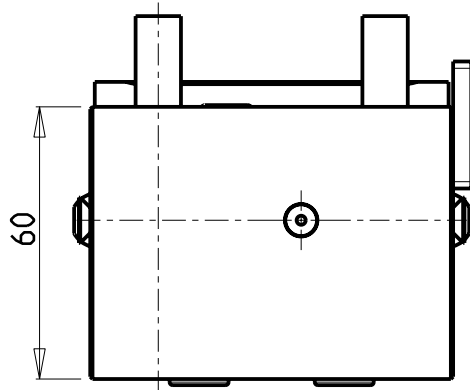
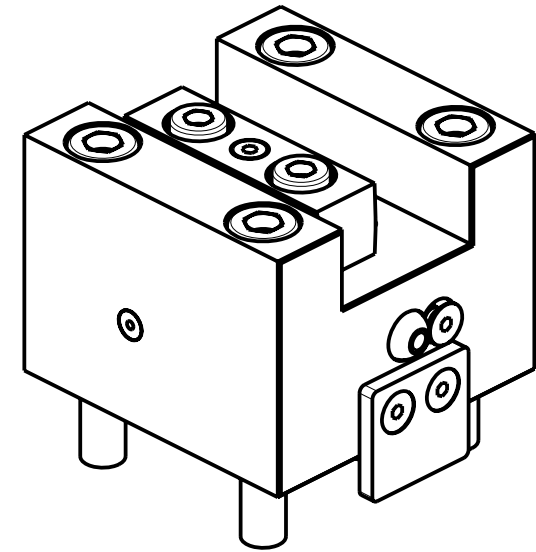
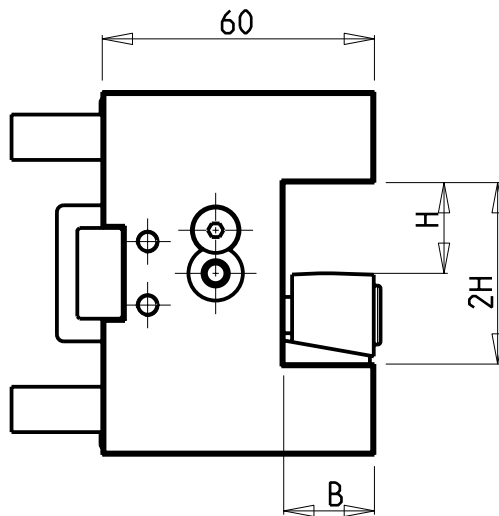
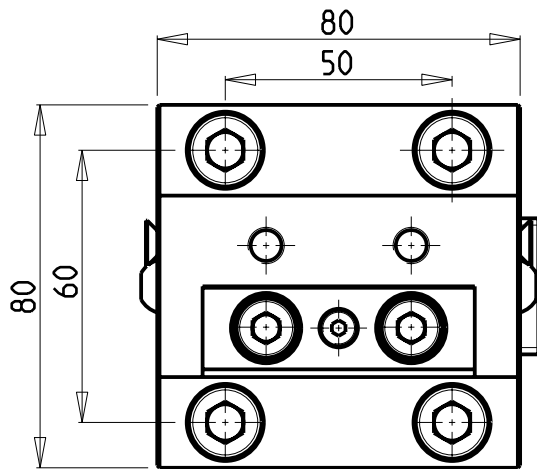

Cod. MT	Cod. NAKAMURA	N°Utensili N°Tools N°Werkzeuge	Reversibile lato mandrino/contromandrino Reversible sub/main spindle side Umkehrbare Spindel-seite/ Gegenspindel-seite	Misure Dimensions Masse	B	H
NKM0182000	W 14 15	1	X	mm	20	20
NKM0181905	W 14 25	1	X	Inch	3/4"	3/4"

NAKAMURA-TOME

WT150/250 - WT15011/25011 - WTW150 - WTS150 - SUPER NTM3 - SUPER NTJ - SUPER NTJX - SC200/250
 NTY3_250 - TW10M/MY/MM/MMY/MMYY-TW20M/MY/MM/MMY/MMYY 16 ST.

PORTAUTENSILE ASSIALE SINGOLO

Axial single static tool

Axial Single-Werkzeughalter

M.T. srl

Via Casino Albini 480
 Tel. 0541/956034-957884
 Fax 0541/956341
 47842 S. GIOVANNI IN M. (RN)
 e-mail: mtma@mtmarchetti.com
 http://www.mtmarchetti.com

PRODUZIONE MODULI ROTANTI



PAGINA NKM550-2-00

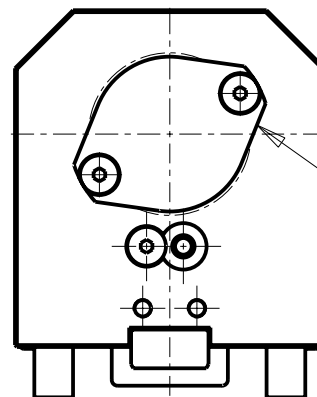
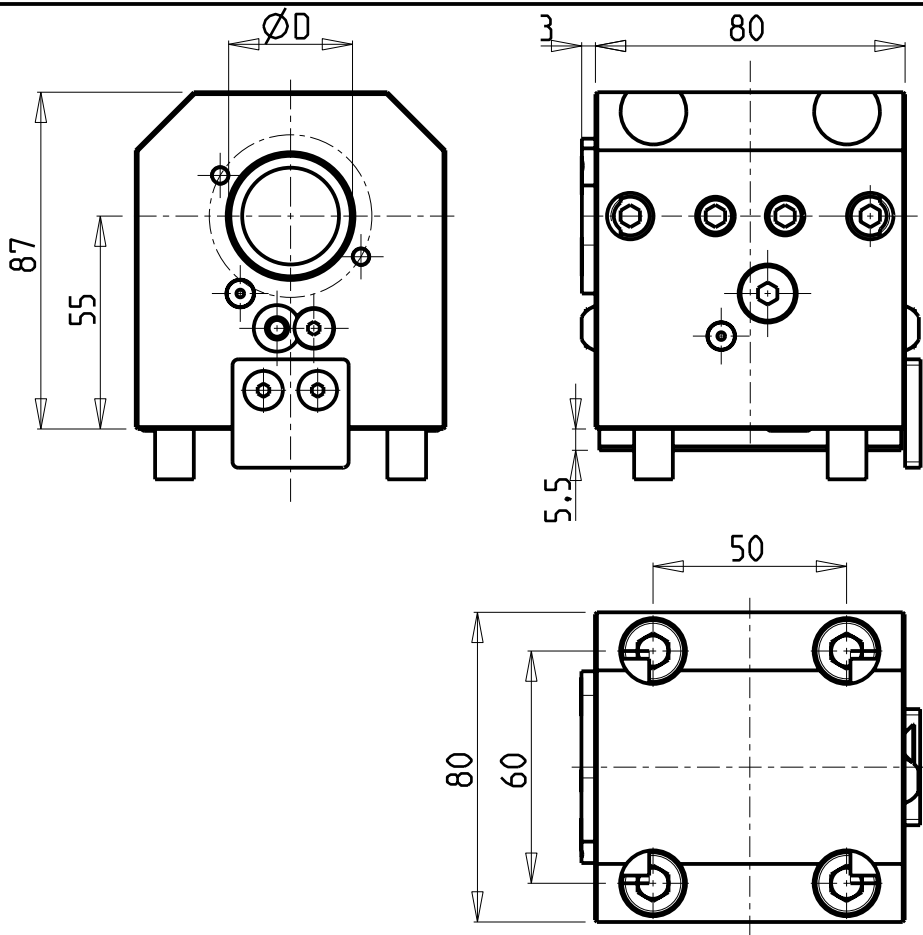

KIT ADDUZIONE INTERNA (OPZIONALE)
 KIT FOR INTERNAL COOLANT (OPTIONAL)
 KIT FUER INTERNE KUEHLMITTELZUFUHR (OPTIONAL)
 Ø32-Ø1 1/4" cod. KIT1000001

PER BOCCOLE DI RIDUZIONE VEDI PAG. TBL150-1-00
 FOR REDUCING BUSHINGS SEE PAGE TBL150-1-00
 FÜR REDUZIERBUCHSE SIEHE SEITE TBL150-1-00

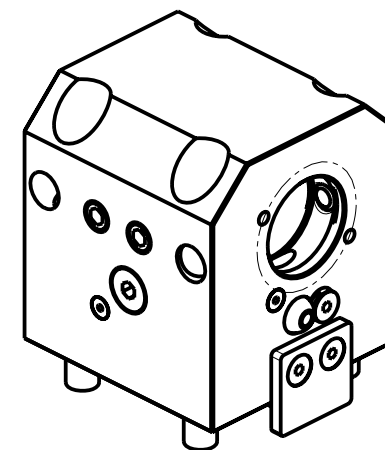

Cod. MT	N°Utensili N°Tools N°Werkzeuge	Reversibile lato mandrino/Contromandrino Reversible sub/main spindle side Umkehrbare Spindel-seite/ Gegenspindel-seite	Lubrificazione int. opzionale Coolant through optional Innenkuehlung Optional	Lubrificazione est. Ext. coolant Aussenkuehlung	Misure Dimensions Masse	D
NKM0113220	1	X	X	X	mm	32
NKM0113230	1	X	X	X	Inch	1 1/4"

NAKAMURA-TOME

WT150/250 - WT15011/25011 - WTW 150 - WTS150 - SUPER NTM3 - SUPER NTJ - SC200/250
 NTY3 250 - TW10M/MY/MM/MMY/MYY-TW20M/MY/MM/MMY/MYY 16 ST.

PORTAUTENSILE ASSIALE PER BARENO Ø32mm / Ø1 1/4" H=55mm

Axial single boring bar holder Ø32mm / Ø1 1/4" H=55mm

Axial Bohrhälter Ø32mm / Ø1 1/4" H=55mm

M.T. srl

Via Casino Albini 480
 Tel. 0541/956034-957884
 Fax 0541/956341
 47842 S. GIOVANNI IN M. (RN)
 e-mail: mtma@mtmarchetti.com
 http://www.mtmarchetti.com

PRODUZIONE MODULI ROTANTI



PAGINA NKM650-2-10

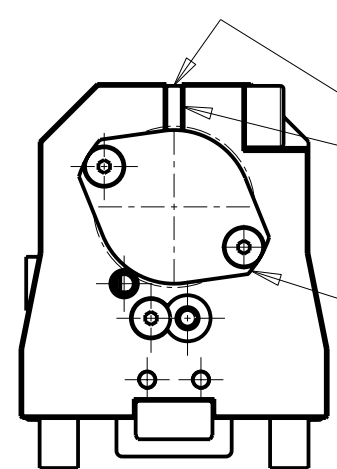
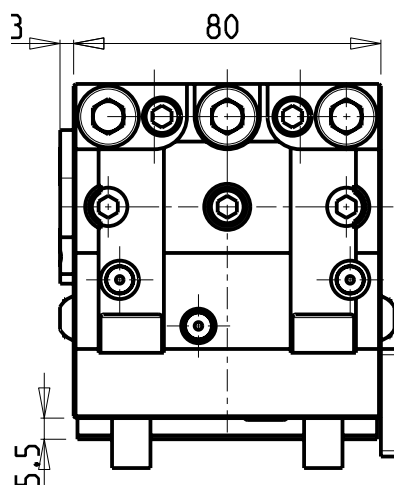
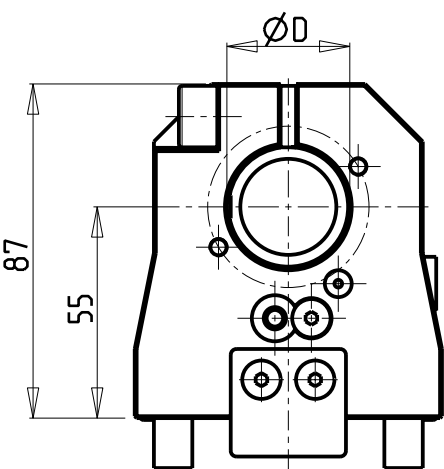

SOLO GUARNIZIONE (OPZIONALE)
 ONLY SEAL (OPTIONAL)
 NUR DICHTUNG (OPTIONAL)
 cod. NKM0110009

KIT ADDUZIONE INTERNA (OPZIONALE)
 KIT FOR INTERNAL COOLANT (OPTIONAL)
 KIT FUER INTERNE KUEHLMITTELZUFUHR (OPTIONAL)
 Ø32-Ø1 1/4" cod. KIT1004001

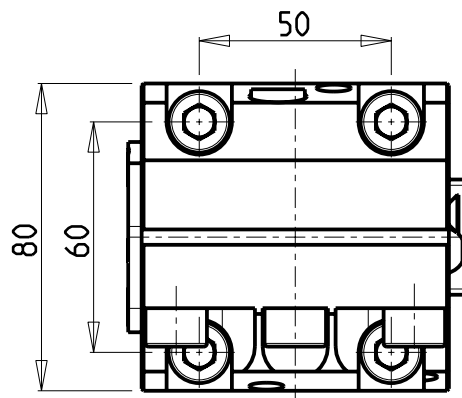

PER BOCCOLE DI RIDUZIONE VEDI PAG. TBL150-1-00
 FOR REDUCING BUSHINGS SEE PAGE TBL150-1-00
 FÜR REDUZIERBUCHSE SIEHE SEITE TBL150-1-00

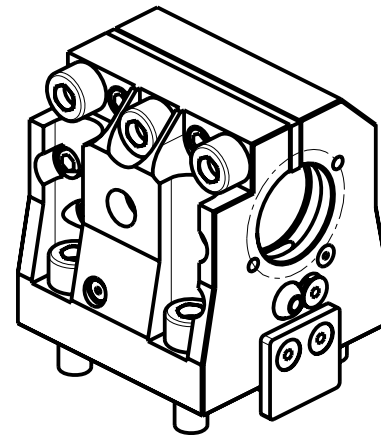

Cod. MT	N°Utensili N°Tools N°Werkzeuge	Reversibile lato mandrino/contromandrino Reversible sub/main spindle side Umkehrbare Spindel-seite/ Gegenspindel-seite	Lubrificazione int. opzionale Coolant through optional Innenkuehlung Optional	Lubrificazione est. Ext. coolant Aussenkuehlung	Misure Dimensions Masse	D
NKM0113221	1	X	X	X	mm	32
NKM0113231	1	X	X	X	Inch	1 1/4"

NAKAMURA-TOME
 WT150/250 - WT15011/25011 - WTW150 - WTS150 - SUPER NTM3 - SUPER NTJ - SC200/250
 NTY3 250 - TW10M/MY/MM/MMY/MMYY-TW20M/MY/MM/MMY/MMYY 16 ST.
 PORTAUTENSILE ASSIALE PER BARENO Ø32mm / Ø1 1/4" H=55mm
 Axial single boring bar holder Ø32mm / Ø1 1/4" H=55mm
 Axial Bohrhälter Ø32mm / Ø1 1/4" H=55mm

PRODOTTORE
 PRODUCER
 HERSTELLER

M.T. srl
 Via Casino Albini 480
 Tel. 0541/956034-957884
 Fax 0541/956341
 47842 S. GIOVANNI IN M. (RN)
 e-mail: mtma@mtmarchetti.com
 http://www.mtmarchetti.com

PRODUZIONE MODULI ROTANTI

PAGINA NKM650-2-20

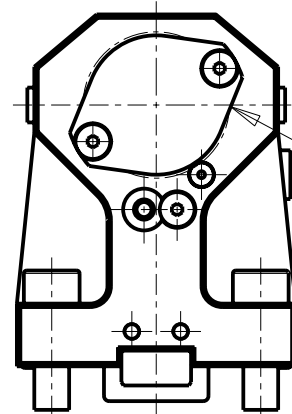
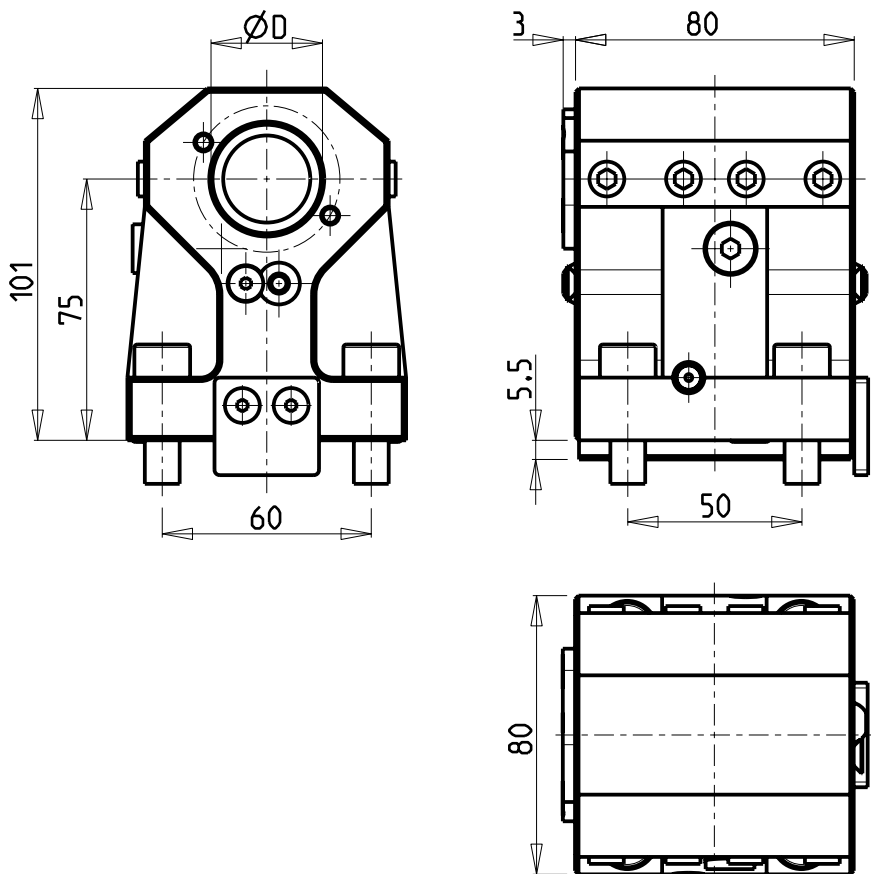

KIT ADDUZIONE INTERNA (OPZIONALE)
 KIT FOR INTERNAL COOLANT (OPTIONAL)
 KIT FUER INTERNE KUEHLMITTELZUFUHR (OPTIONAL)
 Ø32-Ø1 1/4" cod. KIT1000001
 Ø40 cod. KIT1000018

PER BOCCOLE DI RIDUZIONE VEDI PAG. TBL150-1-00
 FOR REDUCING BUSHINGS SEE PAGE TBL150-1-00
 FUR REDUZIERBUCHSE SIEHE SEITE TBL150-1-00

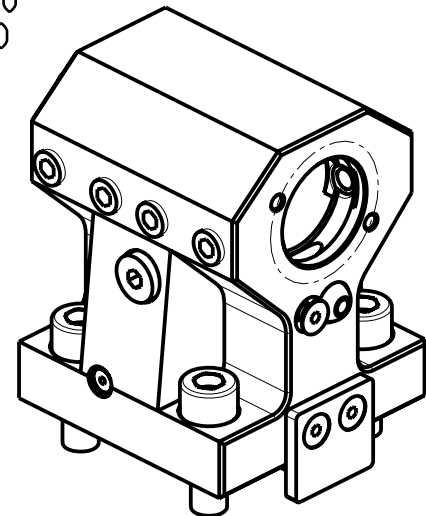

Cod. MT	N°Utensili N°Tools N°Werkzeuge	Reversibile lato mandrino/contromandrino Reversible sub/main spindle side Umkehrbare Spindelseite/ Gegenspindelseite	Lubrificazione int. opzionale Coolant through optional Innenkuehlung Optional	Lubrificazione est. Ext. coolant Aussenkuehlung	Misure Dimensions Masse	D
NKM0114000	1	X	X	X	mm	40
NKM0113200	1	X	X	X	mm	32
NKM0113210	1	X	X	X	Inch	1 1/4"

NAKAMURA-TOME
 WT150/250 - WT15011/25011 - WTW150 - WTS150 - SUPER NTM3 - SUPER NTJ - SUPER NTJX - SC200/250
 NTY3_250 - TW10M/MY/MM/MMY/MMYY-TW20M/MY/MM/MMY/MMYY 16 ST.
 PORTAUTENSILE ASSIALE PER BARENO Ø40mm / Ø32mm / Ø1 1/4" H=75 mm
 Axial single boring bar holder Ø40mm / Ø32mm / Ø1 1/4" H=75mm
 Axial Bohrhalter Ø40mm / Ø32mm / Ø1 1/4" H=75mm

M.T. srl
 Via Casino Albini 480
 Tel. 0541/956034-957884
 Fax 0541/956341
 47842 S. GIOVANNI IN M. (RN)
 e-mail: mtma@mtmarchetti.com
 http://www.mtmarchetti.com

PRODUZIONE MODULI ROTANTI

PAGINA NKM660-2-10

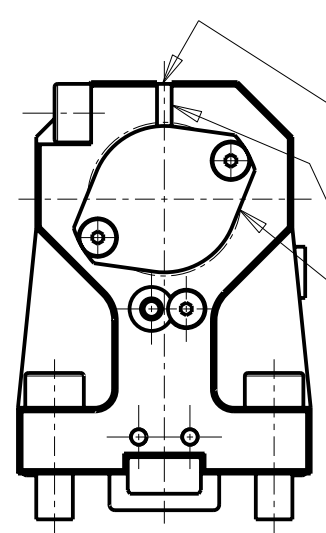
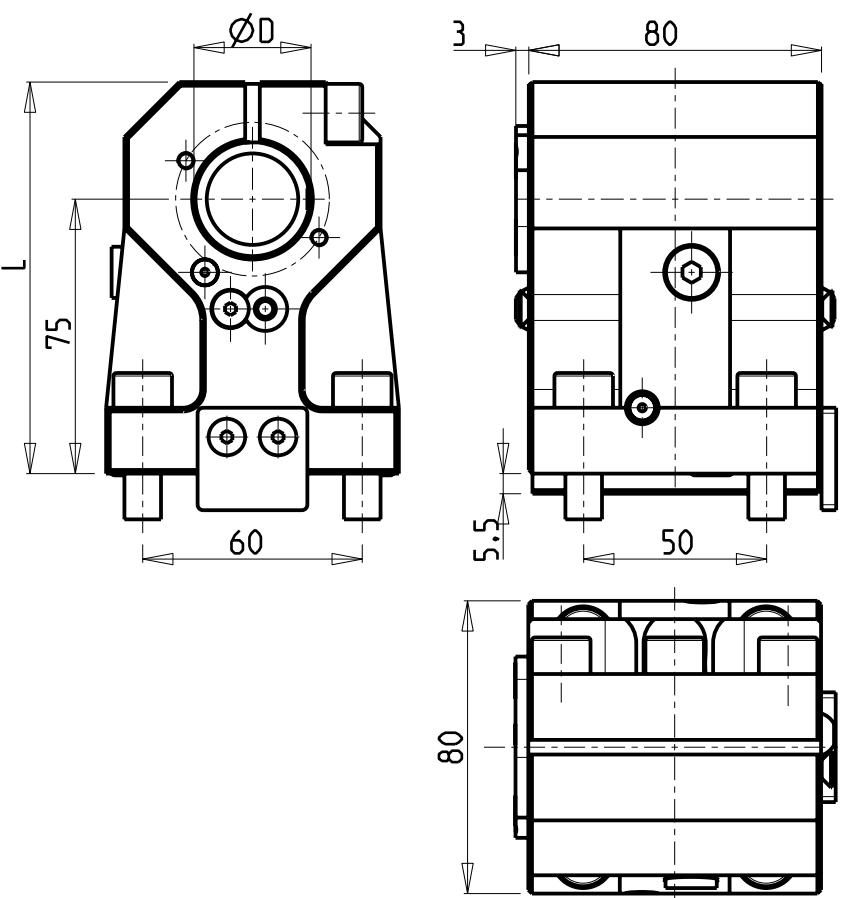

SOLO GUARNIZIONE (OPZIONALE)
 ONLY SEAL (OPTIONAL)
 NUR DICHTUNG (OPTIONAL)
 cod. NKM0110009

KIT ADDUZIONE INTERNA (OPZIONALE)
 KIT FOR INTERNAL COOLANT (OPTIONAL)
 KIT FUER INTERNE KUEHLMITTELZUFUHR (OPTIONAL)
 Ø32-Ø1 1/4" cod. KIT1004001
 Ø40 cod. KIT1004018

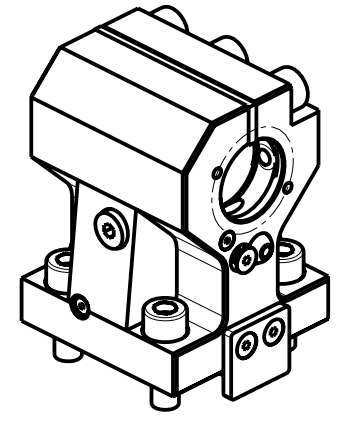
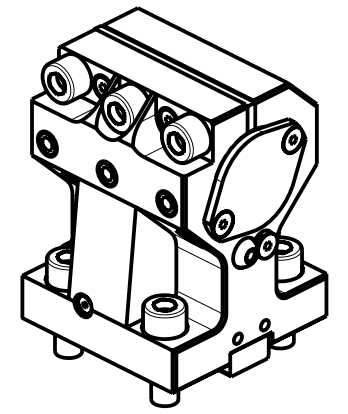

PER BOCCOLE DI RIDUZIONE VEDI PAG. TBL150-1-00
 FOR REDUCING BUSHINGS SEE PAGE TBL150-1-00
 FUR REDUZIERBUCHSE SIEHE SEITE TBL150-1-00

Cod. MT	N°Utensili N°Tools N°Werkzeuge	Reversibile lato mandrino/contromandrino Reversible sub/main spindle side Umkehrbare Spindel-seite/ Gegenspindel-seite	Lubrificazione int. opzionale Coolant through optional Innenkuehlung Optional	Lubrificazione est. Ext. coolant Aussenkuehlung	D	L
NKM0114010	1	X	X	X	40	111
NKM0113201	1	X	X	X	32	107
NKM0113211	1	X	X	X	1 1/4"	107

NAKAMURA-TOME

WT250 - WT150II/250II - WTW150 - WTS150 - SC200/250 - SUPER NTJX - NTY3 250

PORTAUTENSILE ASSIALE PER BARENO Ø40mm / Ø32mm / Ø1 1/4" H=75mm
 Axial single boring bar holder Ø40mm / Ø32mm / Ø1 1/4" H=75mm
 Axial Bohrhalter Ø40mm / Ø32mm / Ø1 1/4" H=75mm



M.T. srl
 Via Casino Albini 480
 Tel. 0541/956034-957884
 Fax 0541/956341
 47842 S. GIOVANNI IN M. (RN)
 e-mail: mtma@mtmarchetti.com
 http://www.mtmarchetti.com

PRODUZIONE MODULI ROTANTI



PAGINA NKM660-2-20

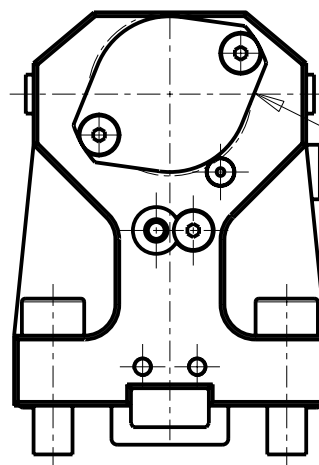
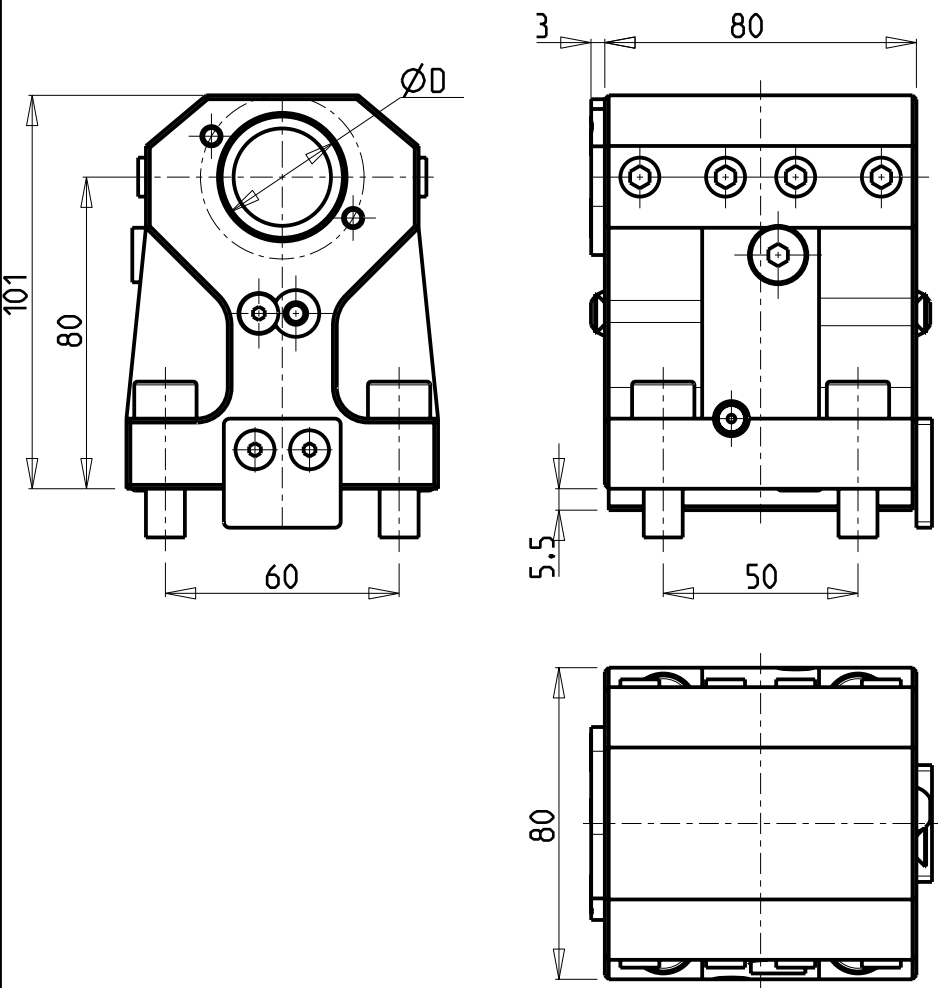

KIT ADDUZIONE INTERNA (OPZIONALE)
 KIT FOR INTERNAL COOLANT (OPTIONAL)
 KIT FUER INTERNE KUEHLMITTELZUFUHR (OPTIONAL)
 Ø32-Ø1 1/4" cod. KIT1000001

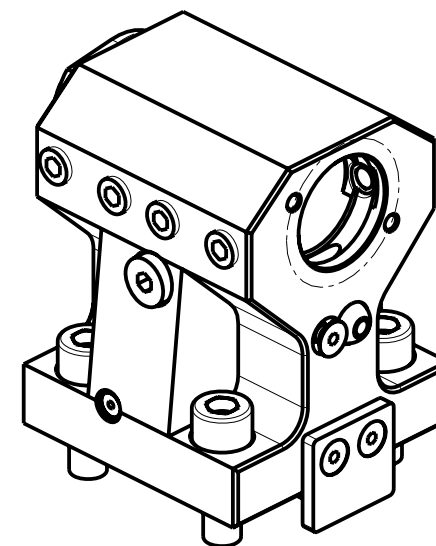

Cod. MT	N°Utensili N°Tools N°Werkzeuge	Reversibile lato mandrino/contromandrino Reversible sub/main spindle side Umkehrbare Spindel-seite/ Gegenspindel-seite	Lubrificazione int. opzionale Coolant through optional Innenkuehlung Optional	Lubrificazione est. Ext. coolant Aussenkuehlung	Misure Dimensions Masse	D
NKM0113240	1	X	X	X	mm	32

PER BOCCOLE DI RIDUZIONE VEDI PAG. TBL150-1-00
 FOR REDUCING BUSHINGS SEE PAGE TBL150-1-00
 FÜR REDUZIERBUCHSE SIEHE SEITE TBL150-1-00

NAKAMURA-TOME

WT150/250 - WT15011/25011 - WTW150 - WTS150 - SUPER NTM3 - SUPER NTJ - SUPER NTJX - SC200/250
 NTY3 250 - TW10M/MY/MM/MYY/MYY - TW20M/MY/MM/MYY/MYY 16 ST.

PORTAUTENSILE ASSIALE PER BARENO Ø32mm H=80mm

Axial single boring bar holder Ø32mm H=80mm

Axial Bohrhälter Ø32mm H=80mm

M.T. srl

Via Casino Albini 480
 Tel. 0541/956034-957884
 Fax 0541/956341
 47842 S. GIOVANNI IN M. (RN)
 e-mail: mtma@mtmarchetti.com
 http://www.mtmarchetti.com

PRODUZIONE MODULI ROTANTI



PAGINA NKM665-2-10

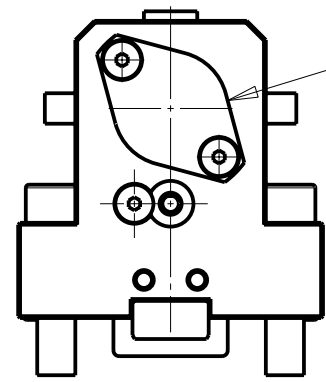
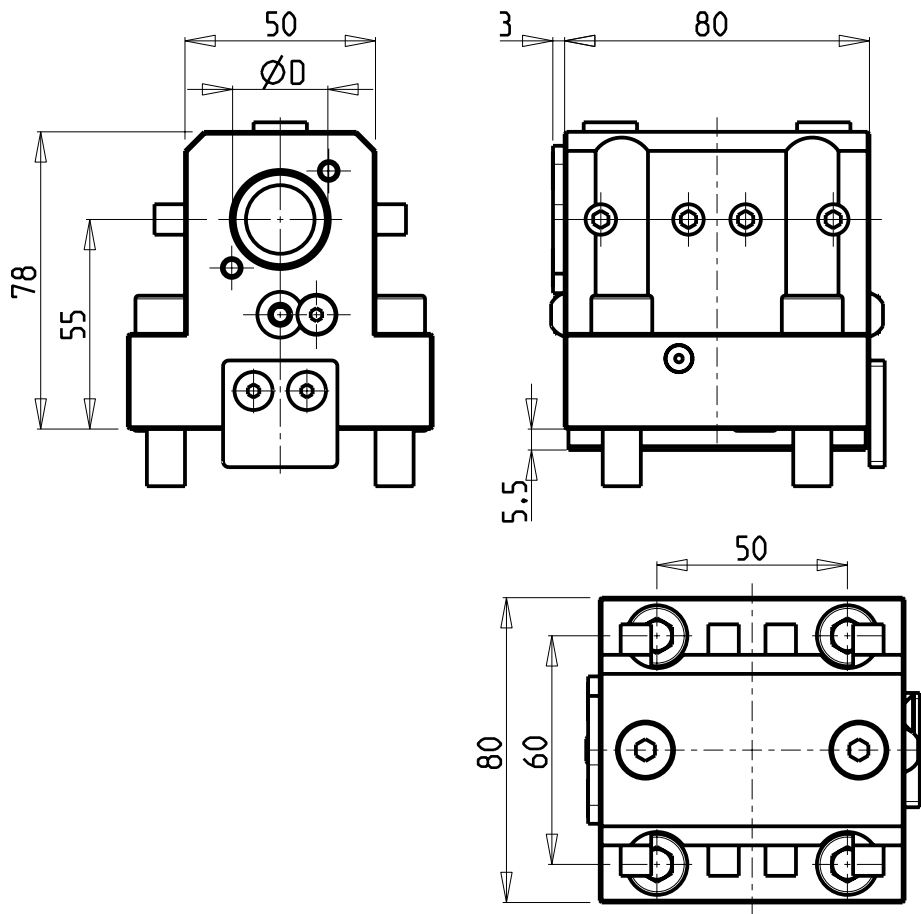

KIT ADDUZIONE INTERNA (OPZIONALE)
 KIT FOR INTERNAL COOLANT (OPTIONAL)
 KIT FUER INTERNE KUEHLMITTELZUFUHR (OPTIONAL)
 Ø25-Ø1" cod. KIT1000006

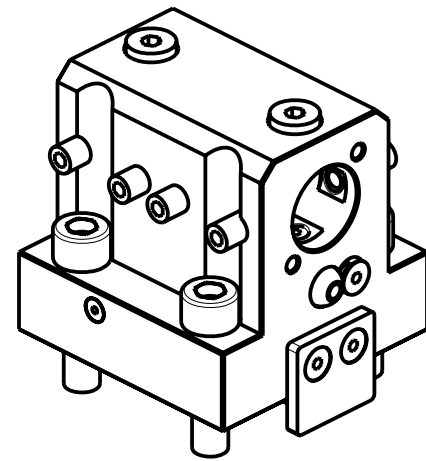

Cod. MT	N°Utensili N°Tools N°Werkzeuge	Reversibile lato mandrino/contromandrino Reversible sub/main spindle side Umkehrbare Spindel-seite/ Gegenspindel-seite	Lubrificazione int. opzionale Coolant through optional Innenkuehlung Optional	Lubrificazione est. Ext. coolant Aussenkuehlung	Misure Dimensions Masse	D
NKM0112500	1	X	X	X	mm	25
NKM0112510	1	X	X	X	Inch	1"

PER BOCCOLE DI RIDUZIONE VEDI PAG. TBL150-1-00
 FOR REDUCING BUSHINGS SEE PAGE TBL150-1-00
 FÜR REDUZIERBUCHSE SIEHE SEITE TBL150-1-00

NAKAMURA-TOME
 WT150/250 - WT15011/25011 - WTW150 - WTS150 - SUPER NTM3 - SUPER NTJ - SC200/250
 NTY3 250 - TW10M/MY/MM/MMY/MYY-TW20M/MY/MM/MMY/MYY 16 ST.
 PORTAUTENSILE ASSIALE PER BARENO Ø25mm / Ø1" H=55mm
 Axial single boring bar holder Ø25mm / Ø1" H=55mm
 Axial Bohrhälter Ø25mm / Ø1" H=55mm



M.T. srl
 Via Casino Albini 480
 Tel. 0541/956034-957884
 Fax 0541/956341
 47842 S. GIOVANNI IN M. (RN)
 e-mail: mtma@mtmarchetti.com
 http://www.mtmarchetti.com

PRODUZIONE MODULI ROTANTI

PAGINA NKM670-2-10

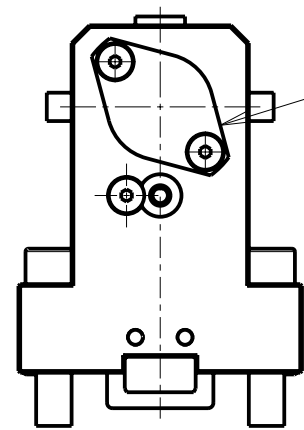
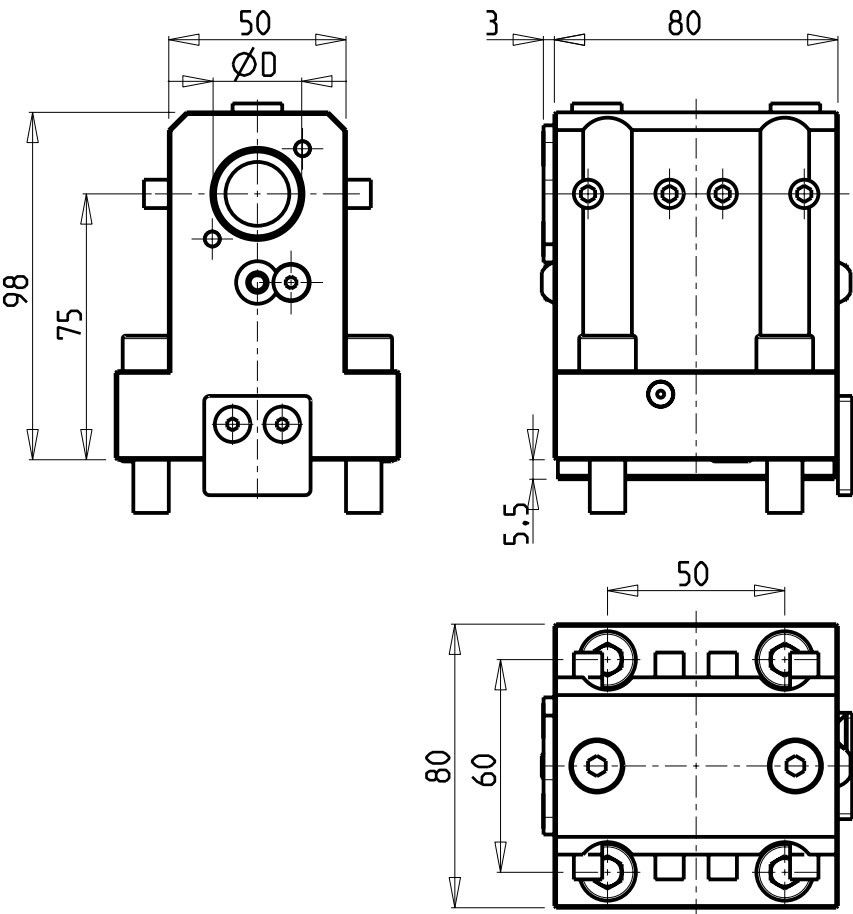

KIT ADDUZIONE INTERNA (OPZIONALE)
 KIT FOR INTERNAL COOLANT (OPTIONAL)
 KIT FUER INTERNE KUEHLMITTELZUFUHR (OPTIONAL)
 Ø25-Ø1" cod. KIT1000006

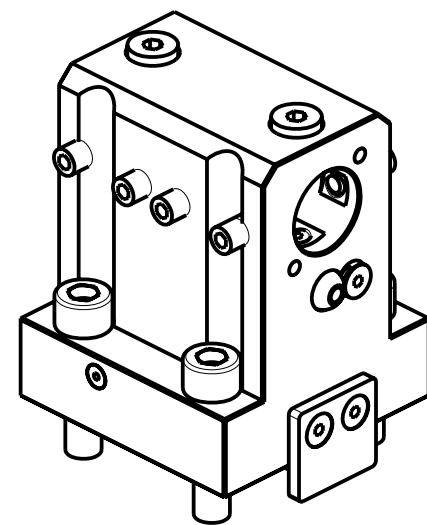

Cod. MT	Cod. NAKAMURA	N°Utensili N° Tools N° Werkzeuge	Reversibile lato mandrino/contromandrino Reversible sub/main spindle side Umkehrbare Spindelseite/ Gegenspindelseite	Lubrificazione int. opzionale Coolant through optional Innenkuehlung Optional	Lubrificazione est. Ext. coolant Aussenkuehlung	Misure Dimensions Masse	D
NKM0112520	W 4437	1	X	X	X	mm	25
NKM0112530	W 4447	1	X	X	X	Inch	1"

PER BOCCOLE DI RIDUZIONE VEDI PAG. TBL150-1-00
 FOR REDUCING BUSHINGS SEE PAGE TBL150-1-00
 FÜR REDUZIERBUCHSE SIEHE SEITE TBL150-1-00

NAKAMURA-TOME
 WT150/250 - WT15011/25011 - WTW150 - WTS150 - SUPER NTM3 - SUPER NTJ - SUPER NTJX - SC200/250
 NTY3 250 - TW10M/MY/MM/MMY/MMYY-TW20M/MY/MM/MMY/MMYY 16 ST.
 PORTAUTENSILE ASSIALE PER BARENO Ø25mm / Ø1" H=75mm
 Axial single boring bar holder Ø25mm / Ø1" H=75mm
 Axial Bohrhälter Ø25mm / Ø1" H=75mm



M.T. srl
 Via Casino Albini 480
 Tel. 0541/956034-957884
 Fax 0541/956341
 47842 S. GIOVANNI IN M. (RN)
 e-mail: mtma@mtmarchetti.com
 http://www.mtmarchetti.com

PRODUZIONE MODULI ROTANTI

PAGINA NKM680-2-10

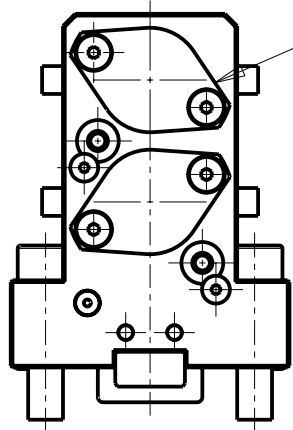
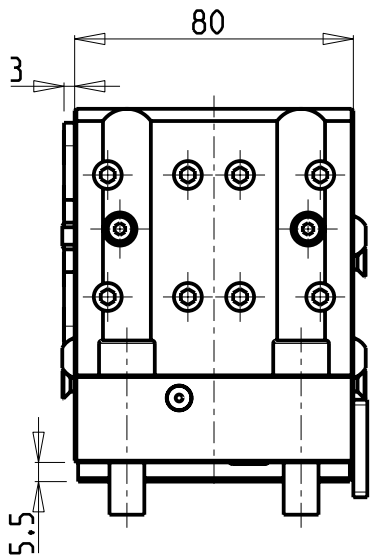
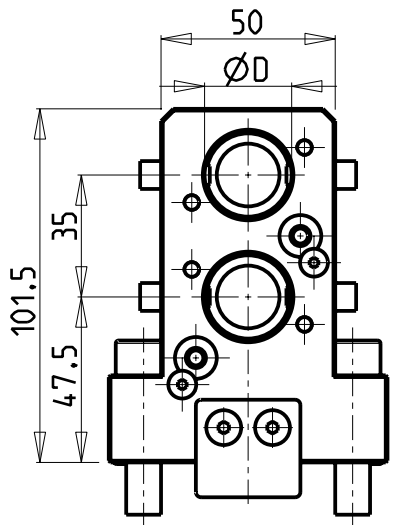

KIT ADDUZIONE INTERNA (OPZIONALE)
 KIT FOR INTERNAL COOLANT (OPTIONAL)
 KIT FUER INTERNE KUEHLMITTELZUFUHR (OPTIONAL)
 Ø25-Ø1" cod. KIT1000006

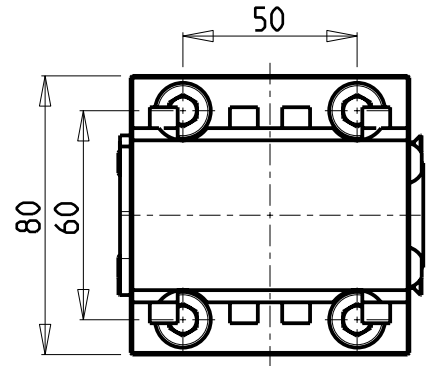
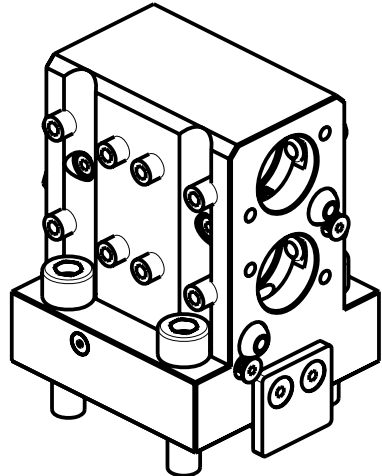

PER BOCCOLE DI RIDUZIONE VEDI PAG. TBL150-1-00
 FOR REDUCING BUSHINGS SEE PAGE TBL150-1-00
 FÜR REDUZIERBUCHSE SIEHE SEITE TBL150-1-00

Cod. MT	Cod. NAKAMURA	N°Utensili N° Tools N° Werkzeuge	Reversibile lato mandrino/contromandrino Reversible sub/main spindle side Umkehrbare Spindel/Seite/ Gegenspindel/Seite	Lubrificazione int. opzionale Coolant through optional Innenkuehlung Optional	Lubrificazione est. Ext. coolant Aussenkuehlung	Misure Dimensions Masse	D
NKM0142500	R8418	2	X	X	X	mm	25
NKM0142510	R8428	2	X	X	X	Inch	1"

NAKAMURA-TOME
 WT150/250 - WT15011/25011 - WTW150 - WTS150 - SUPER NTM3 - SUPER NTJ - SC200/250
 NTY3 250 - TW10M/MY/MM/MMY/MMYY-TW20M/MY/MM/MMY/MMYY 16 ST.
 PORTAUTENSILE ASSIALE PER BARENO 2 POSIZIONI Ø25mm / Ø1"
 Axial double boring bar holder Ø25mm / Ø1"
 Axial Bohrrhalter 2 Positionen Ø25mm / Ø1"



M.T. srl
 Via Casino Albini 480
 Tel. 0541/956034-957884
 Fax 0541/956341
 47842 S. GIOVANNI IN M. (RN)
 e-mail: mtma@mtmarchetti.com
 http://www.mtmarchetti.com

PRODUZIONE MODULI ROTANTI

PAGINA NKM864-2-00

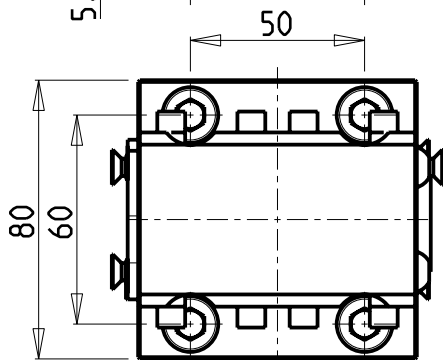
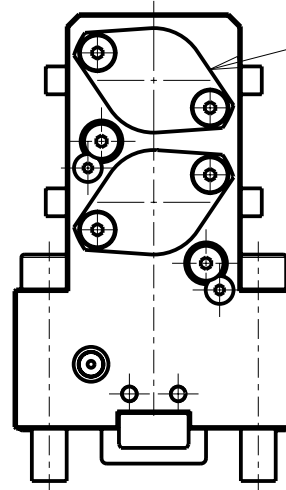
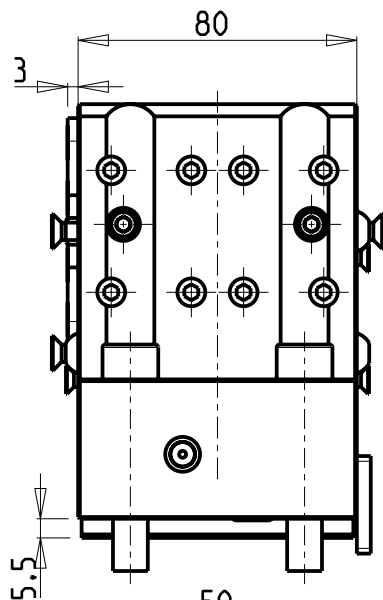
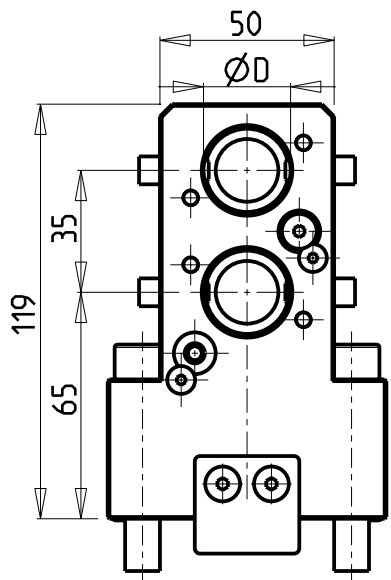

KIT ADDUZIONE INTERNA (OPZIONALE)
 KIT FOR INTERNAL COOLANT (OPTIONAL)
 KIT FUER INTERNE KUEHLMITTELZUFUHR (OPTIONAL)
 Ø25-Ø1" cod. KIT1000006

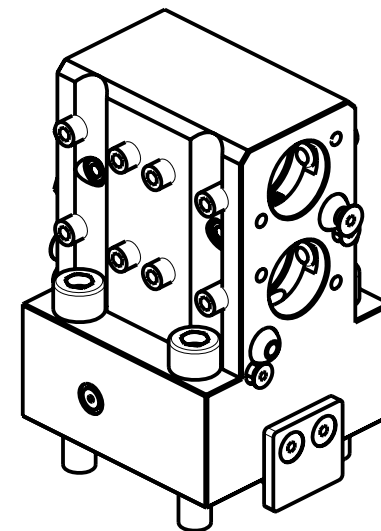

PER BOCCOLE DI RIDUZIONE VEDI PAG. TBL150-1-00
 FOR REDUCING BUSHINGS SEE PAGE TBL150-1-00
 FÜR REDUZIERBUCHSE SIEHE SEITE TBL150-1-00

Cod. MT	N°Utensili N°Tools N°Werkzeuge	Reversibile lato mandrino/contromandrino Reversible sub/main spindle side Umkehrbare Spindel-seite/ Gegenspindel-seite	Lubrificazione int. opzionale Coolant through optional Innenkuehlung Optional	Lubrificazione est. Ext. coolant Aussenkuehlung	Misure Dimensions Masse	D
NKM0652500	2	X	X	X	mm	25
NKM0652540	2	X	X	X	Inch	1"

NAKAMURA-TOME

MOD: W TW 150

PORTAUTENSILE ASSIALE PER BARENO 2 POSIZIONI Ø25mm / Ø1"

Axial double boring bar holder Ø25mm / Ø1"

Axial Bohrhälter 2 Positionen Ø25mm / Ø1"

M.T. srl

Via Casino Albini 480
 Tel. 0541/956034-957884
 Fax 0541/956341
 47842 S. GIOVANNI IN M. (RN)
 e-mail: mtma@mtmarchetti.com
 http://www.mtmarchetti.com

PRODUZIONE MODULI ROTANTI



PAGINA NKM864-2-10

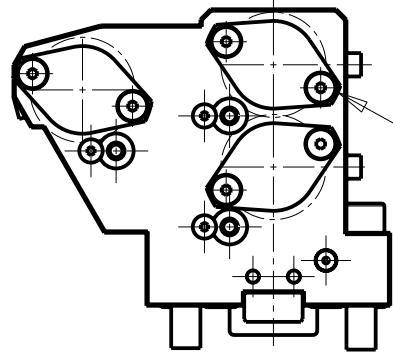
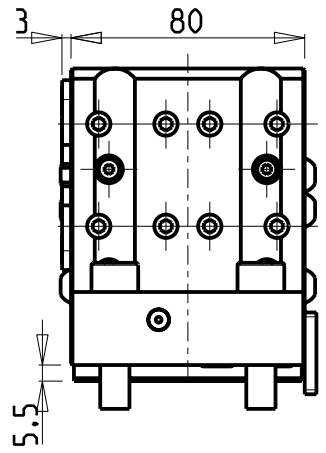
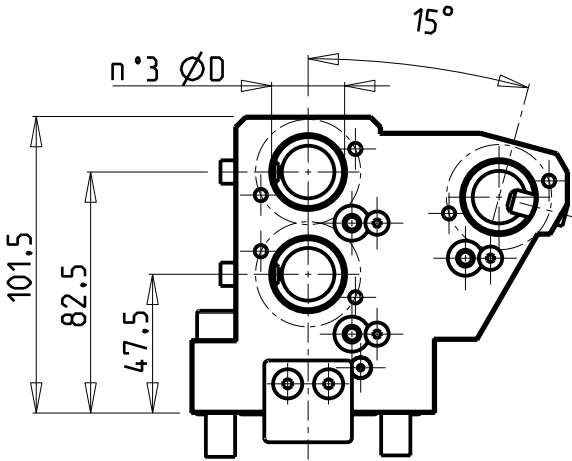

KIT ADDUZIONE INTERNA (OPZIONALE)
 KIT FOR INTERNAL COOLANT (OPTIONAL)
 KIT FUER INTERNE KUEHLMITTELZUFUHR (OPTIONAL)
 Ø25-Ø1" cod. KIT1000006

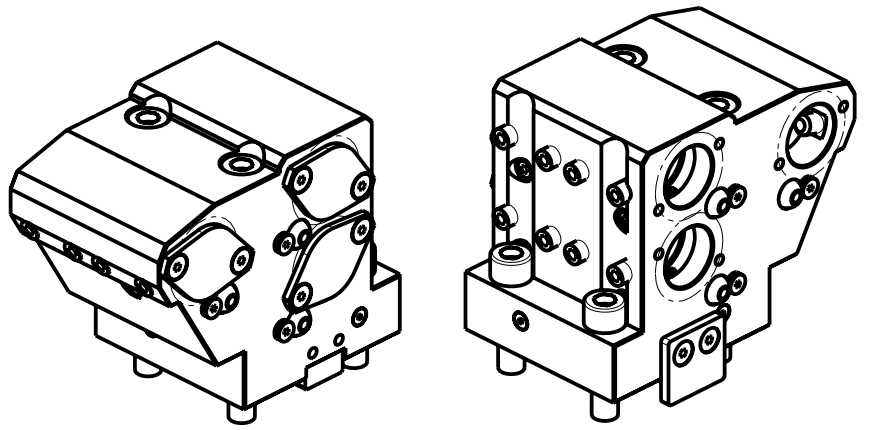
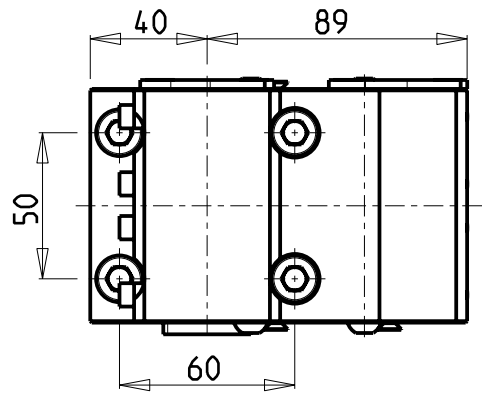

Cod. MT	N°Utensili N°Tools N°Werkzeuge	Reversibile lato mandrino/contromandrino Reversible sub/main spindle side Umkehrbare Spindelseite/ Gegenspindelseite	Lubrificazione int. opzionale Coolant through optional Innenkuehlung Optional	Lubrificazione est. Ext. coolant Aussenkuehlung	Misure Dimensions Masse	D
NKM0211000	3	X	X	X	mm	25
NKM0212540	3	X	X	X	Inch	1"

PER BOCCOLE DI RIDUZIONE VEDI PAG. TBL150-1-00
 FOR REDUCING BUSHINGS SEE PAGE TBL150-1-00
 FÜR REDUZIERBUCHSE SIEHE SEITE TBL150-1-00

NAKAMURA-TOME
 MOD: WT150 - WT15011 - SUPER NTM3 - NTY3 250 - SUPER NTJ
 PORTAUTENSILE ASSIALE PER BARENO 3 POSIZIONI Ø25mm / Ø1"
 Axial 3 position boring bar holder Ø25mm / Ø1"
 Axial Bohrhalter 3 Positionen Ø25mm / Ø1"



M.T. srl
 Via Casino Albini 480
 Tel. 0541/956034-957884
 Fax 0541/956341
 47842 S. GIOVANNI IN M. (RN)
 e-mail: mtma@mtmarchetti.com
 http://www.mtmarchetti.com

PRODUZIONE MODULI ROTANTI

PAGINA NKM884-2-00

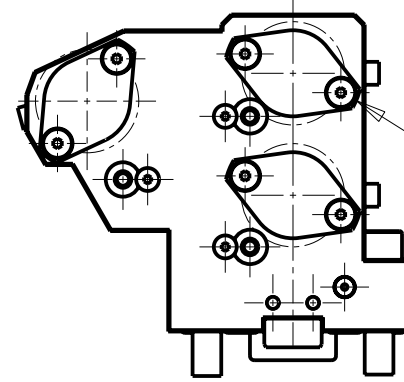
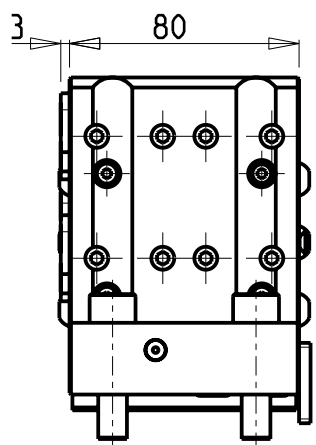
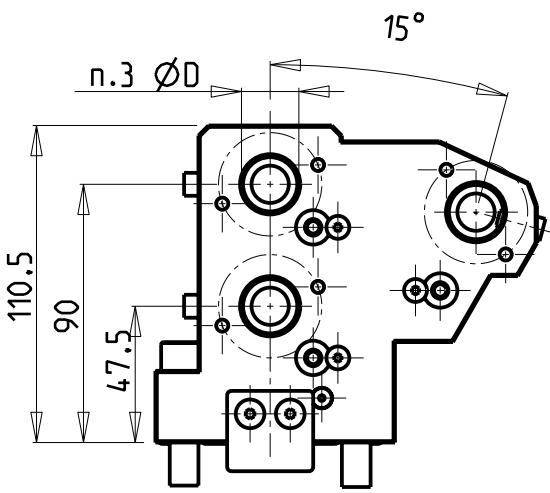

KIT ADDUZIONE INTERNA (OPZIONALE)
 KIT FOR INTERNAL COOLANT (OPTIONAL)
 KIT FUER INTERNE KUEHLMITTELZUFUHR (OPTIONAL)
 Ø20 cod. KIT1000015
 Ø25-Ø1" cod. KIT1000006

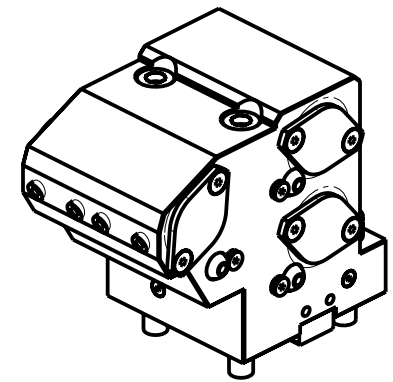
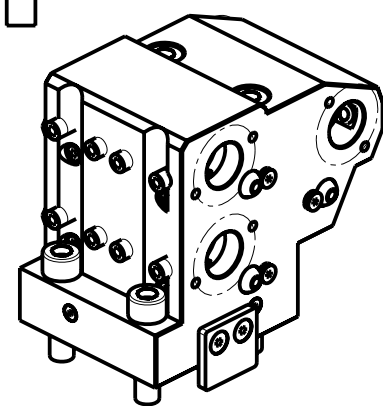
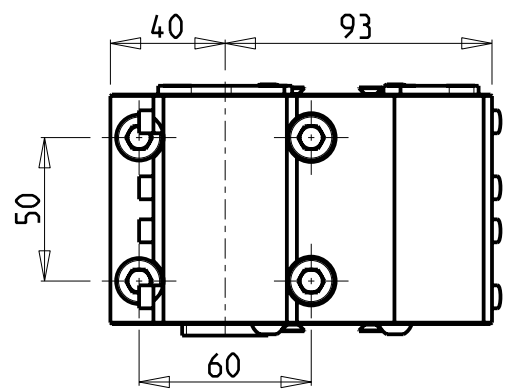

Cod. MT	N°Utensili N°Tools N°Werkzeuge	Reversibile lato mandrino/contromandrino Reversible sub/main spindle side Umkehrbare Spindel-seite/ Gegenspindel-seite	Lubrificazione int. opzionale Coolant through optional Innenkuehlung Optional	Lubrificazione est. Ext. coolant Aussenkuehlung	Misure Dimensions Masse	D
NKM0212000	3	X	X	X	mm	20
NKM0212500	3	X	X	X	mm	25

PER BOCCOLE DI RIDUZIONE VEDI PAG. TBL150-1-00
 FOR REDUCING BUSHINGS SEE PAGE TBL150-1-00
 FÜR REDUZIERBUCHSE SIEHE SEITE TBL150-1-00

NAKAMURA-TOME
 MOD: W TW 150 - W TS150 - SUPER NTJX
 PORTAUTENSILE ASSIALE PER BARENO 3 POSIZIONI Ø20mm / Ø25mm
 Axial 3 position boring bar holder Ø20mm / Ø25mm
 Axial Bohrhälter 3 Positionen Ø20mm / Ø25mm



M.T. srl
 Via Casino Albini 480
 Tel. 0541/956034-957884
 Fax 0541/956341
 47842 S. GIOVANNI IN M. (RN)
 e-mail: mtma@mtmarchetti.com
 http://www.mtmarchetti.com

PRODUZIONE MODULI ROTANTI



PAGINA NKM886-2-00

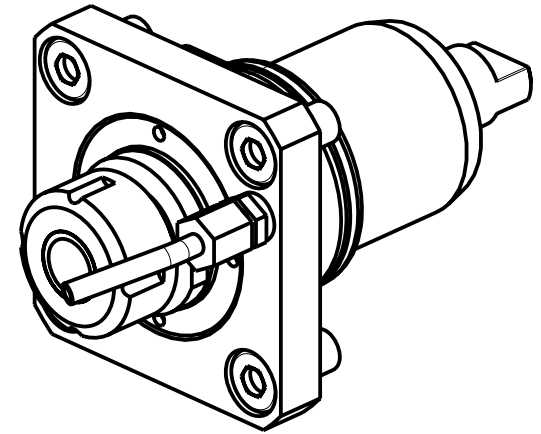
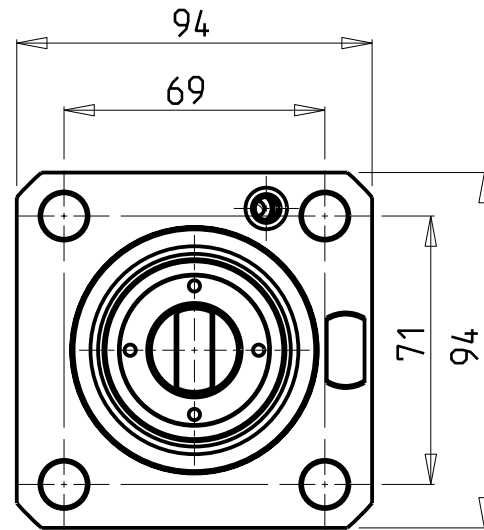
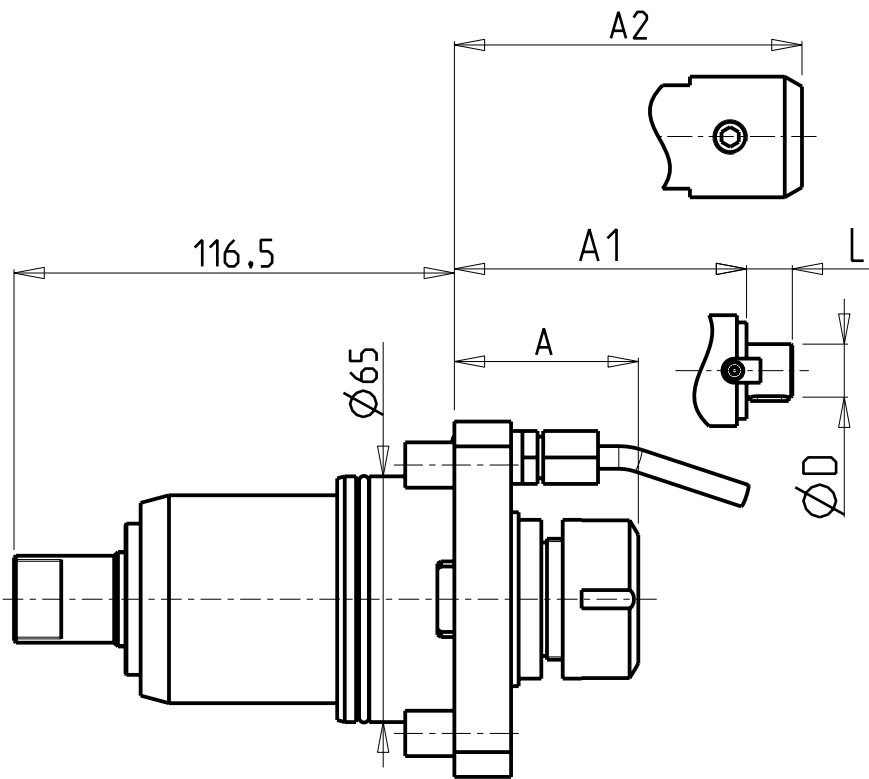

- Chiave inclusa
- Key included
- Schluessel inbegriffen

Cod. MT	Mandrino Spindel Spindel	I	RPM	Coppia Max Max Torque Max Drehmoment	Lubrificazione int. Coolant through Innenkuehlung	Lubrificazione est. Ext. coolant Aussenkuehlung	A	A1	A2	D	L	CHIAVI NON INCLUDE Keys not included Schluessel nicht einbegriffen	
NKM0270125	ER25	1:1	6000	70Nm		X	48.66	-	-	-	-	CHUB42	CHSTER25
NKM0270132	ER32	1:1	6000	70Nm		X	52.16	-	-	-	-	CHUB42	CHSTER32
NKM0270225	ER A 25	1:1	6000	70Nm	P=30bar	X	60.03	-	-	-	-	CHUB46	CHUB27
NKM0270232	ER A 32	1:1	6000	70Nm	P=30bar	X	67.53	-	-	-	-	CHUB46	CHUB32
NKM0270422	Ø22x19	1:1	6000	70Nm		X	-	35	-	22	19	CHUB42	CH_VTCROCE_M10
NKM0270325	WELDON 25	1:1	6000	70Nm	P=30bar	X	-	-	65	-	-		

NAKAMURA-TOME

WT300 - SC300 - SUPER NTX - SUPER NTXL - TW20M/MY/MM/MMY/MYY 12 ST. - TW30M/MY/MM/MMY/MYY 16 ST.

MODULO MOTORIZZATO RADIALE
Radial driven tool
Radial angetriebenes Werkzeug

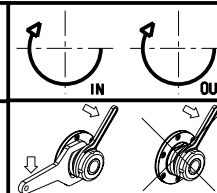

M.T. srl

Via Casino Albini 480
Tel. 0541/956034-957884
Fax 0541/956341
47842 S. GIOVANNI IN M. (RN)
e-mail: mtma@mtmarchetti.com
http://www.mtmarchetti.com

PRODUZIONE MODULI ROTANTI



PAGINA NKM010-3-00

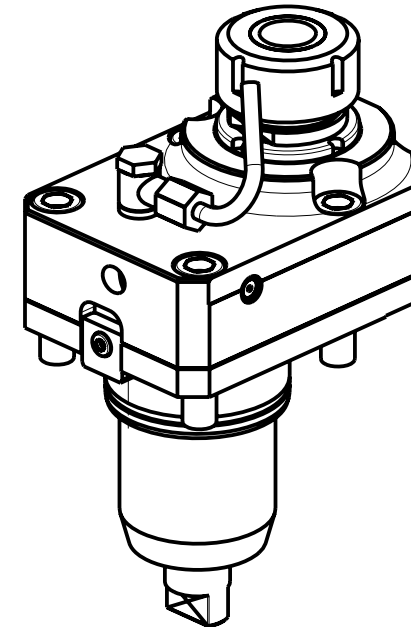
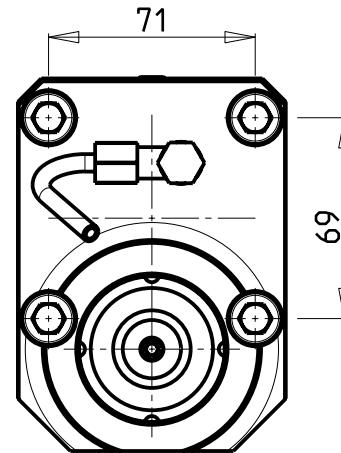
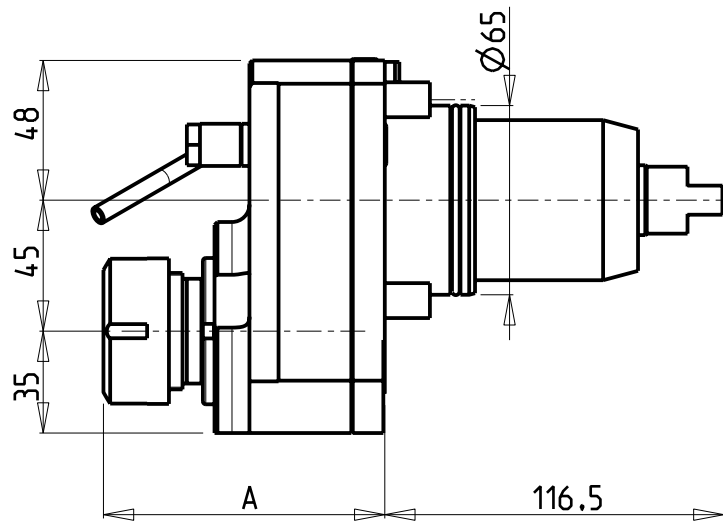
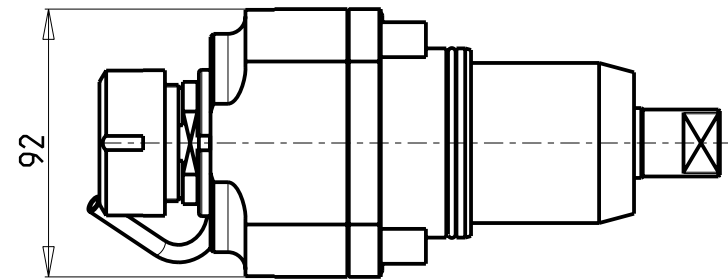

Cod. MT	Mandrino Spindle Spindel	I	RPM	Coppia Max Max Torque Max Drehmoment	Reversibile lato mandrino/contromandrino Reversible sub/main spindle side Umkehrbare Spindelseite/ Gegenspindelseite	Lubrificazione est. Ext. coolant Aussenkuehlung	A	CHIAVI NON INCLUSE Keys not included Schlüssel nicht einbegriffen
NKM0660132	ER32	1:2	12000	30Nm	X	X	96.6	CHSTER32 MNL0210007

NAKAMURA-TOME

WT300 - SC300 - SUPER NTX - SUPER NTXL - TW20M/MY/MM/MMY/MYY 12 ST. - TW30M/MY/MM/MMY/MYY 16 ST.

MODULO MOTORIZZATO RADIALE MOLTIPLICATO I=1:2 DISASSATO IN Z 45mm
 Radial geared-up I=1:2 driven tool re-directed in Z by 45mm
 Radial angetriebenes Werkzeug uebersetzt I=1:2 achsversetzt in Z um 45mm

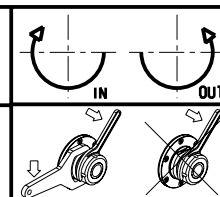

M.T. srl

Via Casino Albini 480
 Tel. 0541/956034-957884
 Fax 0541/956341
 47842 S. GIOVANNI IN M. (RN)
 e-mail: mtma@mtmarchetti.com
 http://www.mtmarchetti.com

PRODUZIONE MODULI ROTANTI



PAGINA NKM030-3-30

ATTENZIONE - ATTENTION - ACHTUNG

- Per lo smontaggio degli utensili utilizzare sempre la chiave di contrasto come indicato nel manuale d'uso.
- For disassembly of the tools use always the contrast key as mentioned in the user instructions.
- Fuer das Abmontieren der Werkzeuge immer den Gegenschlüssel benutzen wie in der Bedienungsanleitung erwäehnt.

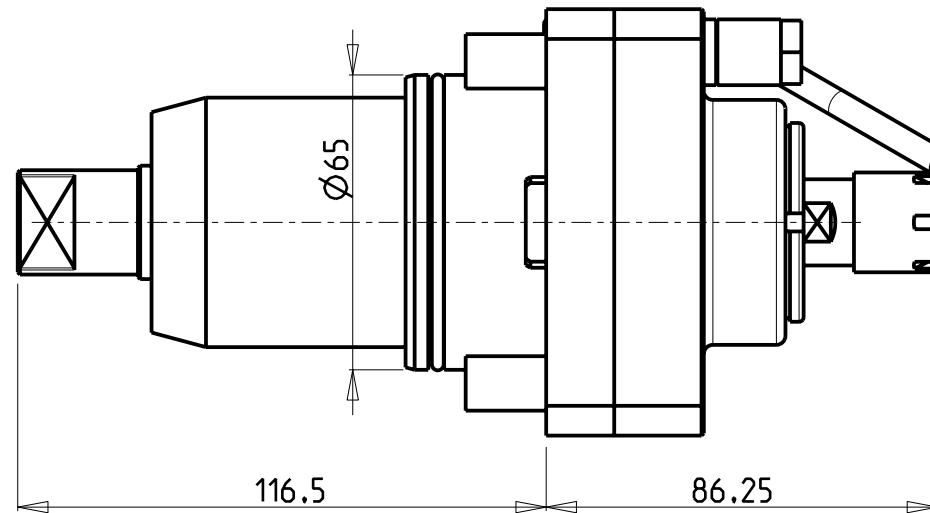
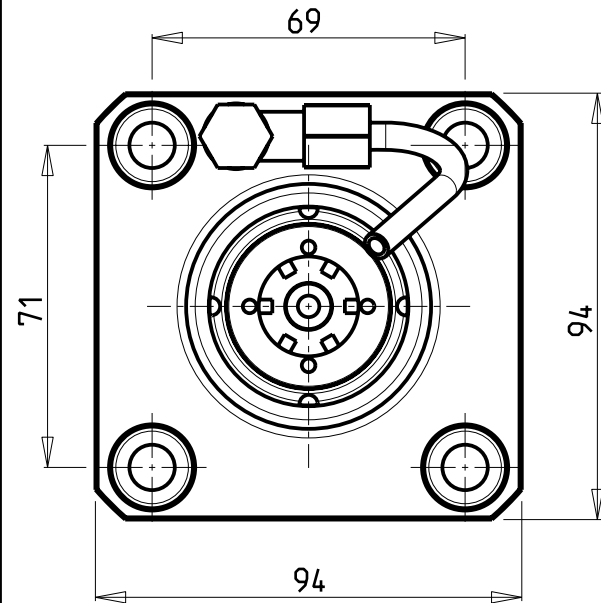

ATTENZIONE - ATTENTION - ACHTUNG

- PRIMA DI UTILIZZARE IL MOTORIZZATO CONSULTARE LE ISTRUZIONI ALLEGATE!
- BEFORE USING THE DRIVEN TOOL, PLEASE CHECK THE ENCLOSED INSTRUCTION SHEET!
- VOR DER BENUTZUNG DES ANGETRIEBENEN WERKZEUGES, DIE BEILIEGENDEN INSTRUKTIONEN DURCHLESEN!

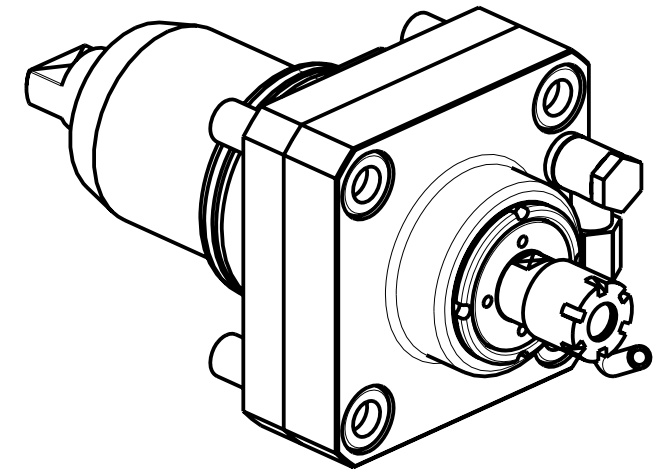

Cod. MT	Mandrino Spindle Spindel	I	RPM	Coppia Max Max Torque Max Drehmoment	Lubrificazione est. Ext. coolant Aussenkuehlung	CHIAVI INCLUSE Keys included Schluessel einbegriffen	
NKM0680116	ER16	1:3	18000	10Nm	X	CHUB17	CHMNER16

NAKAMURA-TOME

WT300 - SC300 - SUPER NTX - SUPER NTXL - TW20M/MY/MM/MMY/MYY 12 ST. - TW30M/MY/MM/MMY/MYY 16 ST.

MODULO MOTORIZZATO RADIALE MOLTIPLICATO I=1:3

Radial geared-up I=1:3 driven tool

Radial angetriebenes Werkzeug uebersetzt I=1:3

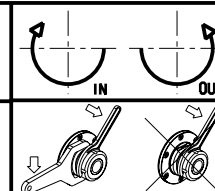

M.T. srl

Via Casino Albini 480
Tel. 0541/956034-957884

Fax 0541/956341

47842 S. GIOVANNI IN M. (RN)

e-mail: mtma@mtmarchetti.com..

http://www.mtmarchetti.com

PRODUZIONE MODULI ROTANTI



PAGINA NKM055-3-00

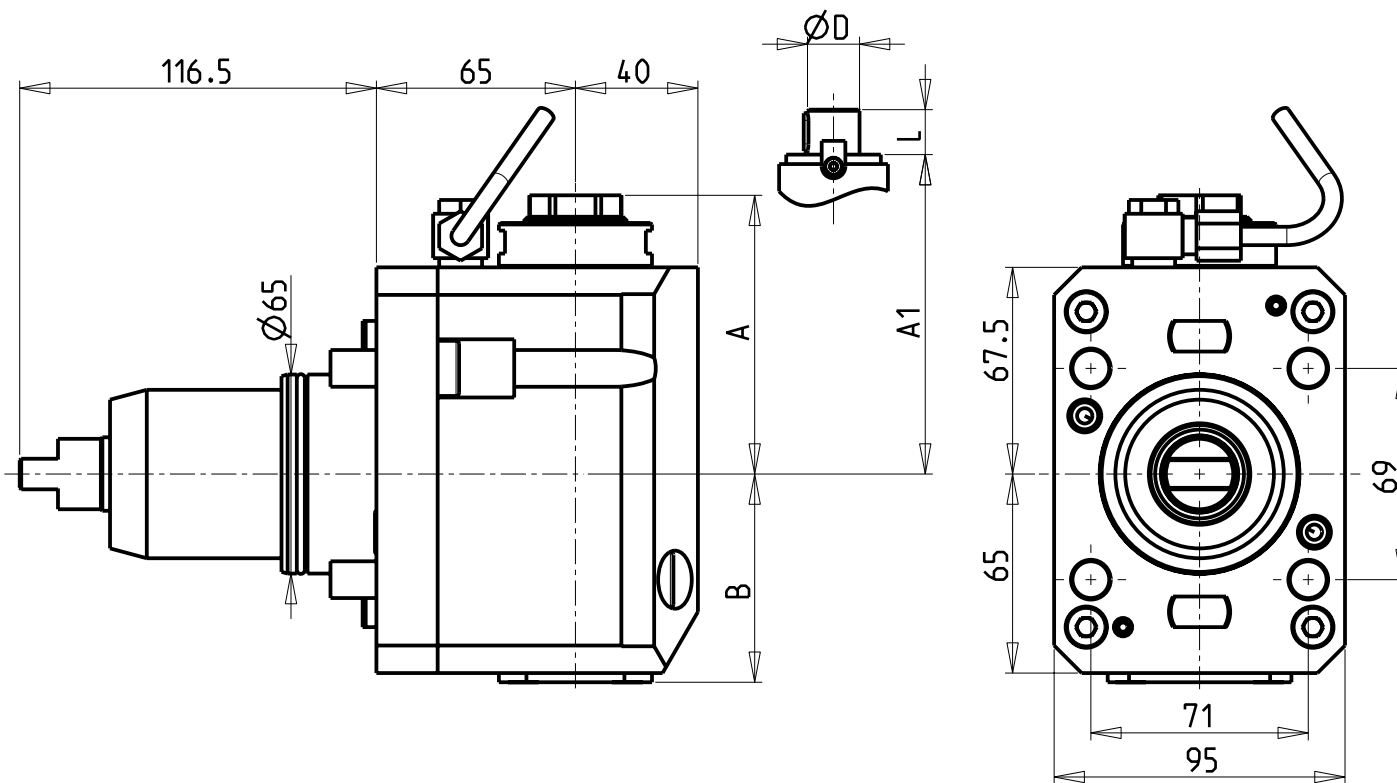

ATTENZIONE - ATTENTION - ACHTUNG

- Per lo smontaggio degli utensili utilizzare sempre la chiave di contrasto come indicato nel manuale d'uso.
- For disassembly of the tools use always the contrast key as mentioned in the user instructions.
- Fuer das Abmontieren der Werkzeuge immer den Gegenschlüssel benutzen wie in der Bedienungsanleitung erwäehnt.

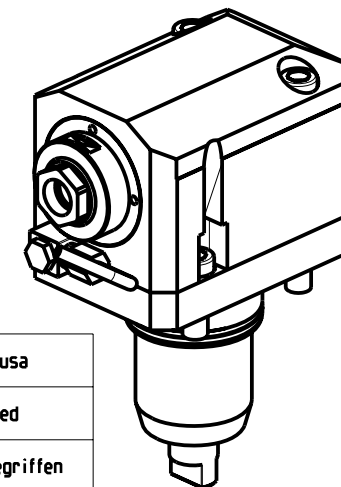

- Chiave inclusa
- Key included
- Schluessel inbegriffen

Cod. MT	Mandrino Spindle Spindel	I	RPM	Coppia Max Max Torque Max Drehmoment	Reversibile lato mandrino/contromandrino Reversible sub/main spindle side Umkehrbare Spindel-seite/ Gegenspindel-seite	Lubr. interna Coolant through Innenkuhlung	Lubr. esterna Ext. coolant Aussenkuhlung	A	A1	B	D	L	CHIAVI NON INCLUDE Keys not included Schluessel nicht einbegriffen	
NKM0260125	ER A 25	1:1	6000	70Nm	X		X	91.03	-	68	-	-	CHUB46	CHUB27
NKM0260132	ER A 32	1:1	6000	70Nm	X		X	94.53	-	68	-	-	CHUB46	CHUB32
NKM0260225	ER A 25	1:1	6000	70Nm	X	P=70bar	X	91.03	-	91.5	-	-	CHUB46	CHUB27
NKM0260232	ER A 32	1:1	6000	70Nm	X	P=70bar	X	94.53	-	91.5	-	-	CHUB46	CHUB32
NKM0262219	Ø22x19	1:1	6000	70Nm	X		X	-	80	68	22	19	CHUB46	CH_VTCROCE_M10 *

NAKAMURA-TOME

WT300 - SC300 - SUPER NTX - SUPER NTXL - TW20M/MY/MM/MMY/MYY 12 ST. - TW30M/MY/MM/MMY/MYY 16 ST.

MODULO MOTORIZZATO ASSIALE H=65mm

Axial driven tool H=65mm

Axial angetriebenes Werkzeug H=65mm

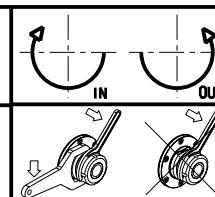

M.T. srl

Via Casino Albini 480
Tel. 0541/956034-957884
Fax 0541/956341

47842 S. GIOVANNI IN M. (RN)
e-mail: mtma@mtmarchetti.com
http://www.mtmarchetti.com

PRODUZIONE MODULI ROTANTI



PAGINA NKM150-3-10

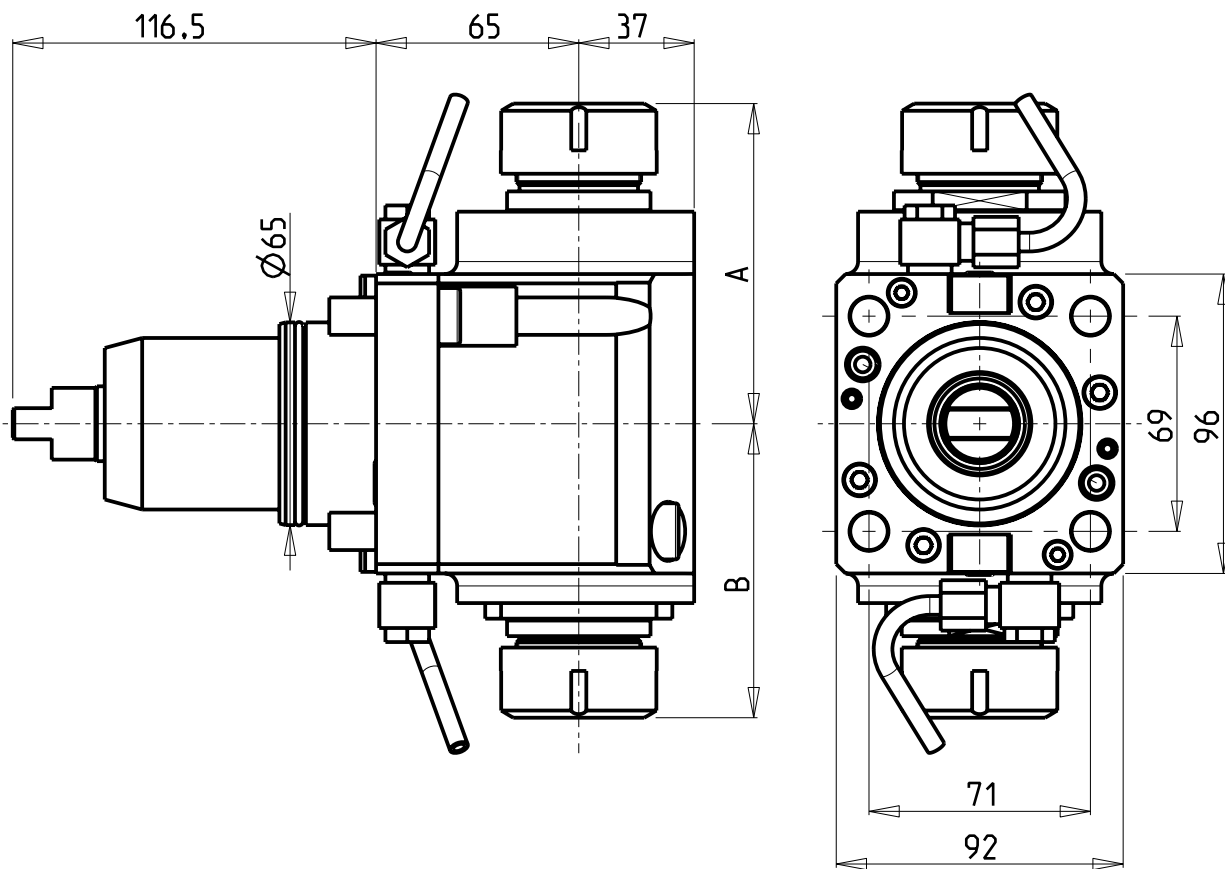

ATTENZIONE - ATTENTION - ACHTUNG

- Per lo smontaggio degli utensili utilizzare sempre la chiave di contrasto come indicato nel manuale d'uso.
- For disassembly of the tools use always the contrast key as mentioned in the user instructions.
- Fuer das Abmontieren der Werkzeuge immer den Gegenschlüssel benutzen wie in der Bedienungsanleitung erwäehnt.

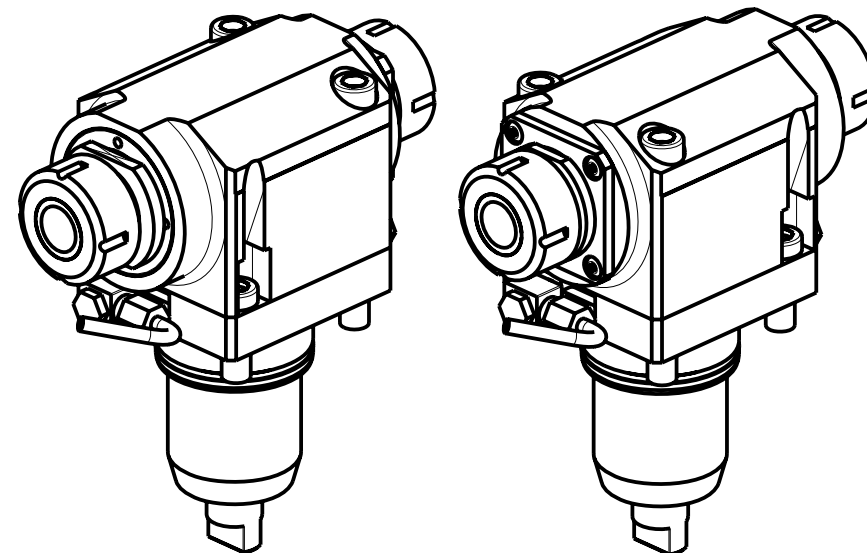

Cod. MT	Mandrino Spindle Spindel	I	RPM	Coppia Max Max Torque Max Drehmoment	Reversibile lato mandrino/contromandrino Reversible sub/main spindle side Umkehrbare Spindel-seite/ Gegenspindel-seite	Lubrificazione est. Ext. coolant Aussenkuehlung	A	B	CHIAVI NON INCLUSE Keys not included Schlues-sel nicht einbegriffen	
NKM0590232	ER32+ER32	1:1	6000	70Nm	X	X	102.66	94.26	CHSTER32	CHUB46

NAKAMURA-TOME

WT300 - SC300 - SUPER NTX - SUPER NTXL - TW20M/MY/MM/MMY/MYY 12 ST. - TW30M/MY/MM/MMY/MYY 16 ST.

MODULO MOTORIZZATO ASSIALE BISPORGENTE H=65mm

Axial opposite face twin driven tool H=65mm

Axial angetriebenes Werkzeug halb vorspringend H=65mm

M.T. srl

Via Casino Albini 480
Tel. 0541/956034-957884
Fax 0541/956341
47842 S. GIOVANNI IN M. (RN)
e-mail: mtma@mtmarchetti.com
http://www.mtmarchetti.com

PRODUZIONE MODULI ROTANTI



PAGINA NKM240-3-10

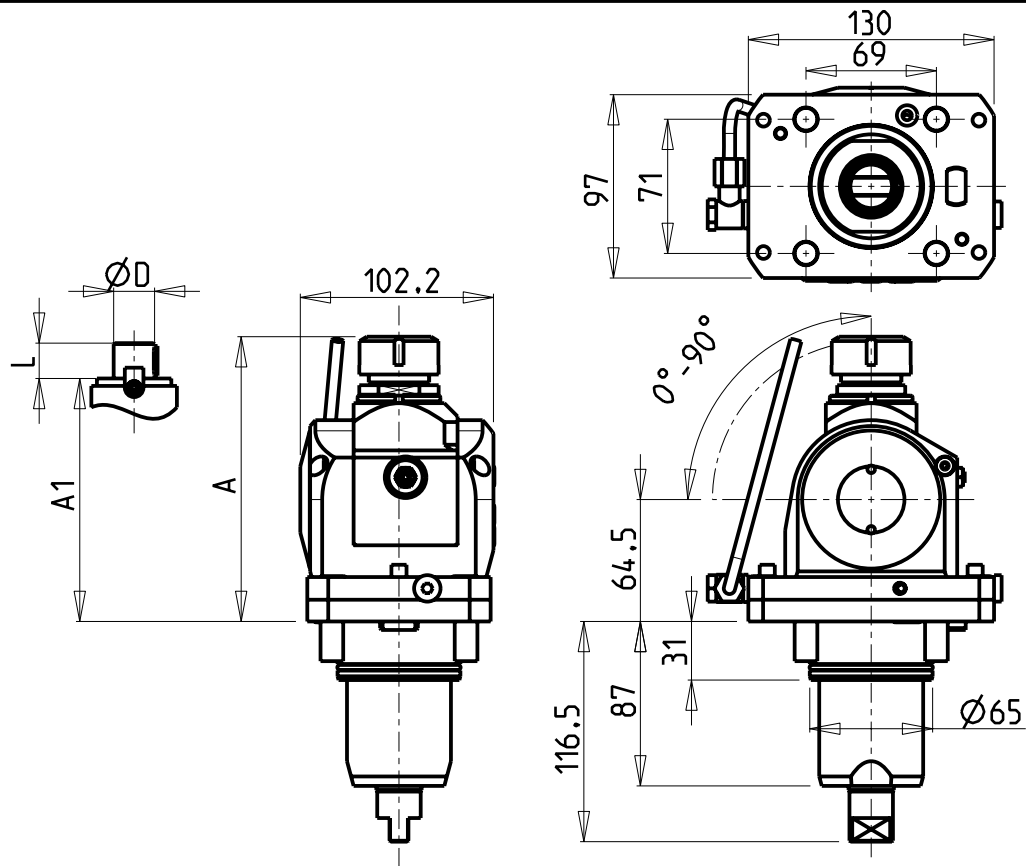

ATTENZIONE - ATTENTION - ACHTUNG

- Per lo smontaggio degli utensili utilizzare sempre la chiave di contrasto come indicato nel manuale d'uso.
- For disassembly of the tools use always the contrast key as mentioned in the user instructions.
- Fuer das Abmontieren der Werkzeuge immer den Gegenschlüssel benutzen wie in der Bedienungsanleitung erwäehnt.

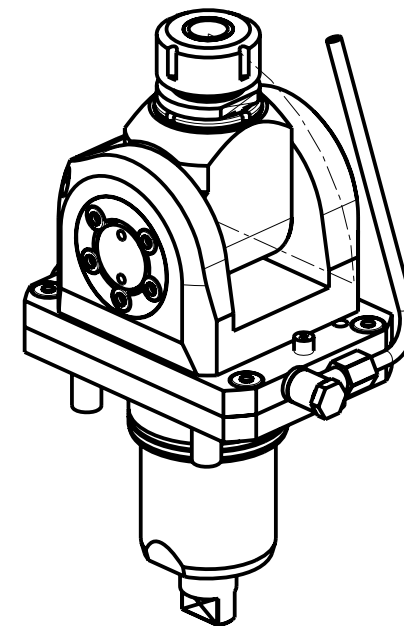

Cod. MT	Mandrino Spindle Spindel	I	RPM	Coppia Max Max Torque Max Drehmoment	Lubrificazione est. Ext. coolant Aussenkuehlung	A	A1	D	L	CHIAVI INCLUSE Keys included Schluessel inbegriffen	
NKM0900020	ER20	1:1	6000	40Nm	X	149.66	-	-	-	CHUB36	CHSTER20
NKM0900025	ER25	1:1	6000	40Nm	X	150.66	-	-	-	CHUB36	CHSTER25
NKM0901617	Ø16x17	1:1	6000	40Nm	X	-	129.5	16	17	CHUB36	CH_VTCROCE_M08
NKM0901905	Ø3/4"x3/4"	1:1	6000	40Nm	X	-	129.5	3/4"	3/4"	CHUB36	CH_VTCROCE_M08
NKM0902219	Ø22x19	1:1	6000	40Nm	X	-	130.5	22	19	CHUB36	CH_VTCROCE_M10

NAKAMURA-TOME

WT300 - SC300 - SUPER NTX - SUPER NTXL - TW20M/MY/MM/MMY/MYY 12 ST. - TW30M/MY/MM/MMY/MYY 16 ST.

MODULO MOTORIZZATO ORIENTABILE 0-90°

0-90° adjustable angle driven tool

Angetriebenes Werkzeug schwenkbar 0-90°

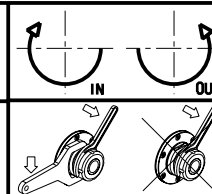

M.T. srl

Via Casino Albini 480
Tel. 0541/956034-957884

Fax 0541/956341

47842 S. GIOVANNI IN M. (RN)

e-mail: mtma@mtmarchetti.com

http://www.mtmarchetti.com

PRODUZIONE MODULI ROTANTI



PAGINA NKM330-3-00

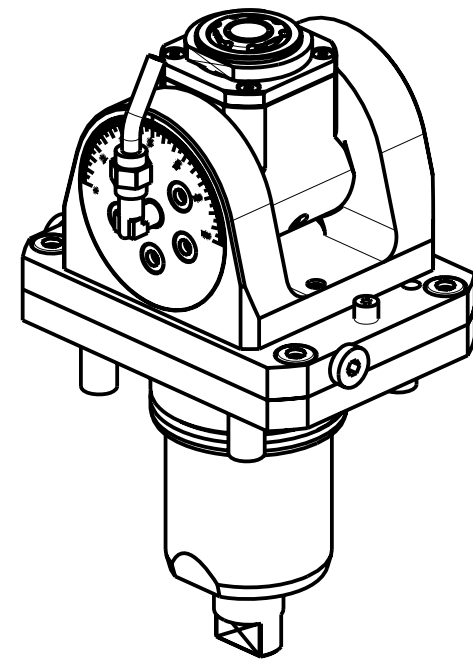
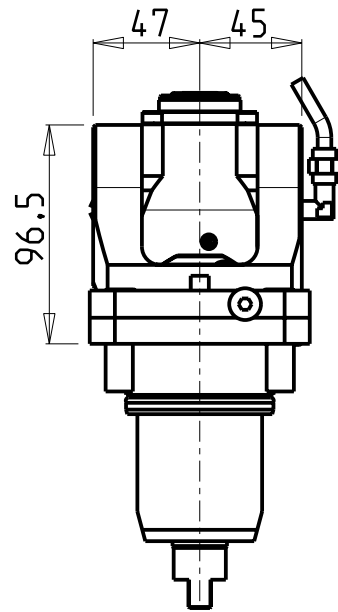
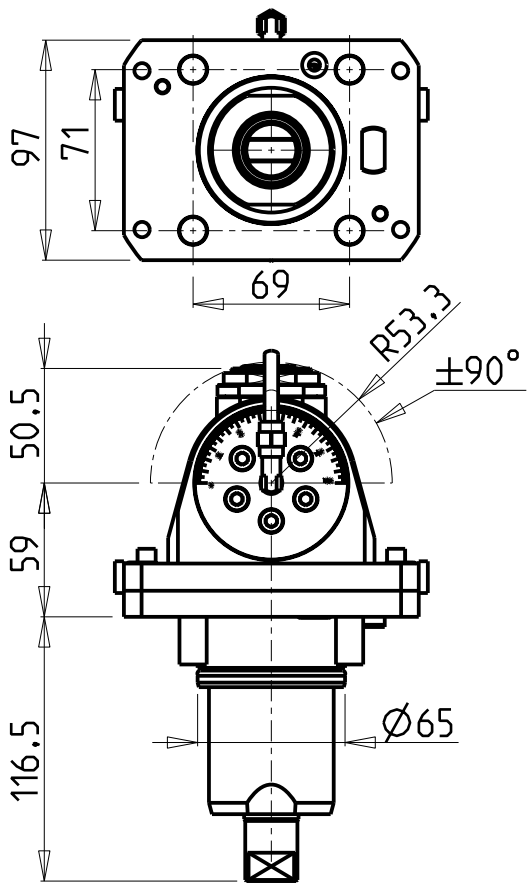

ATTENZIONE - ATTENTION - ACHTUNG

- Per lo smontaggio degli utensili utilizzare sempre la chiave di contrasto come indicato nel manuale d'uso.
- For disassembly of the tools use always the contrast key as mentioned in the user instructions.
- Fuer das Abmontieren der Werkzeuge immer den Gegenschlüssel benutzen wie in der Bedienungsanleitung erwäehnt.

ATTENZIONE - ATTENTION - ACHTUNG

- Verificare la tabella sottostante per possibile interferenza su alcuni modelli di macchine
- Please check the table below for possible interferences on some machine models
- Die untenstehende tabelle unbedingt auf eventuelle interferenzen auf einigen maschinen modellen überprüfen

Cod. MT	Mandrino Spindle Spindel	I	RPM	Coppia Max Max Torque Max Drehmoment	Lubr.interna Coolant through Innenkuehlung	Lubrificazione est. Ext. coolant Aussenkuehlung	CHIAVI INCLUSE Keys included Schlüssel inbegriffen				
							CHUB22	CHUB36	CHESL05	CHESL08	CHTAER20ZC
NKM0800120	ERA20	1:1	6000	30Nm		X	CHUB22	CHUB36	CHESL05	CHESL08	CHTAER20ZC
NKM0800220	ERA20	1:1	6000	30Nm	P=70bar	X	CHUB22	CHUB36	CHESL05	CHESL08	CHTAER20ZC

NEW
NEW

NAKAMURA-TOME

WT300 - SC300 - SUPER NTX - SUPER NTXL - TW20M/MY/MM/MMY/MYY 12 ST. - TW30M/MY/MM/MMY/MYY 16 ST.

MODULO MOTORIZZATO ORIENTABILE ±90°
±90° adjustable angle driven tool
Angetriebenes Werkzeug schwenkbar ±90°

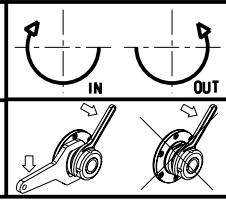

M.T. srl
Via Casino Albini 480
Tel. 0541/956034-957884
Fax 0541/956341
47842 S. GIOVANNI IN M. (RN)
e-mail: mtma@mtmarchetti.com
http://www.mtmarchetti.com

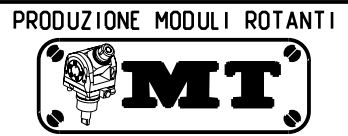

PAGINA NKM335-3-00

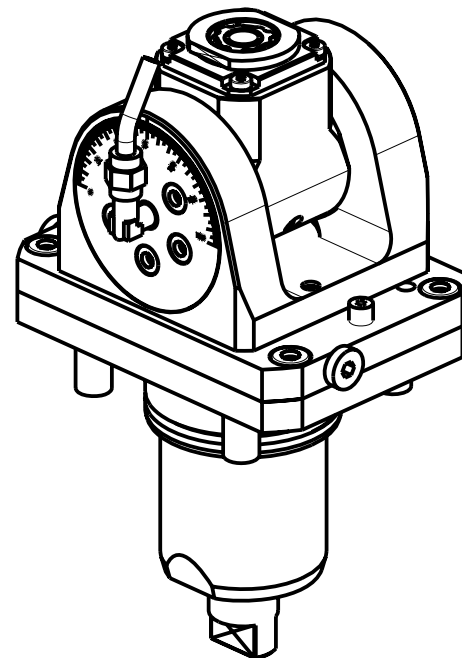
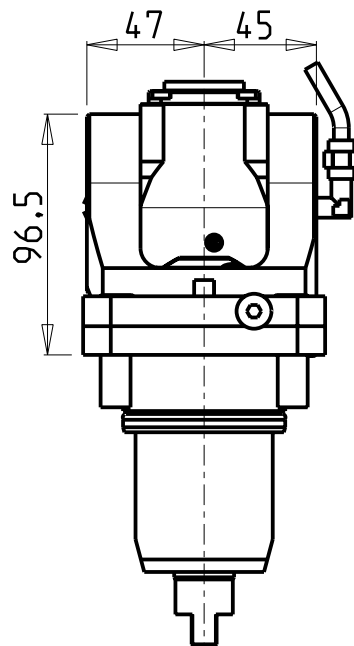
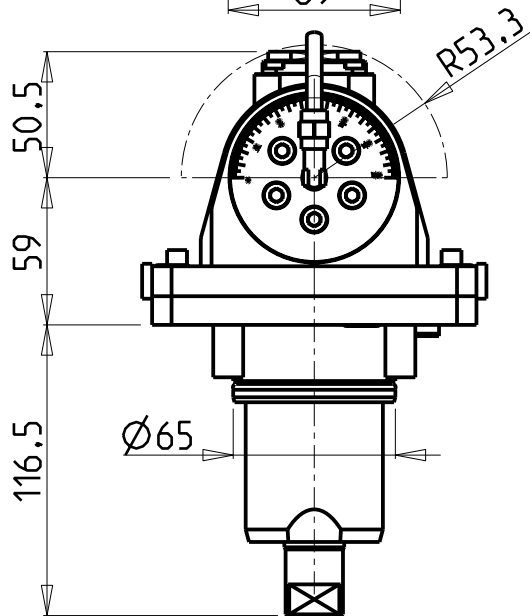
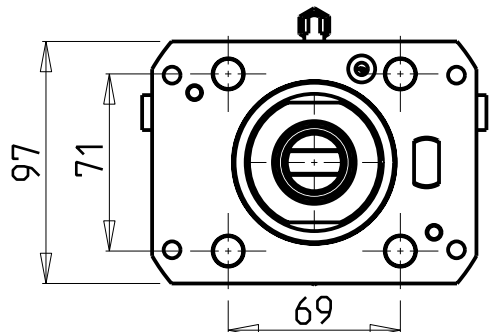

ATTENZIONE - ATTENTION - ACHTUNG

- Per lo smontaggio degli utensili utilizzare sempre la chiave di contrasto come indicato nel manuale d'uso.
- For disassembly of the tools use always the contrast key as mentioned in the user instructions.
- Fuer das Abmontieren der Werkzeuge immer den Gegenschlüssel benutzen wie in der Bedienungsanleitung erwaeht.

ATTENZIONE - ATTENTION - ACHTUNG

- Verificare la tabella sottostante per possibile interferenza su alcuni modelli di macchine
- Please check the table below for possible interferences on some machine models
- Die untenstehende tabelle unbedingt auf eventuelle interferenzen auf einigen maschinen modellen ueberpruefen

Cod. MT	Mandrino Spindle Spindel	I	RPM	Coppia Max Max Torque Max Drehmoment	Lubr.interna Coolant through Innenkuehlung	Lubrificazione est. Ext. coolant Aussenkuehlung	CHIAVI INCLUSE Keys included Schluessel inbegriffen					
NKM0800316	ERA16	1:2	12000	8Nm		X	CHUB19_SP3	CHUB32	CHESL05	CHESL08	CHTAER16ZC	NEW
NKM0800416	ERA16	1:2	12000	8Nm	P=70bar	X	CHUB19_SP3	CHUB32	CHESL05	CHESL08	CHTAER16ZC	NEW

NAKAMURA-TOME

WT300 - SC300 - SUPER NTX - SUPER NTXL - TW20M/MY/MM/MMY/MYY 12 ST. - TW30M/MY/MM/MMY/MYY 16 ST.

MODULO MOTORIZZATO ORIENTABILE +/-90° MOLTIPLICATO I=1:2

+/-90° adjustable angle driven tool geared-up I=1:2

Angetriebenes Werkzeug schwenkbar +/-90° uebersetzt I=1:2

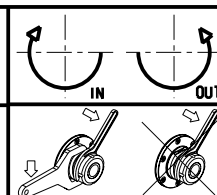

M.T. srl

Via Casino Albini 480
Tel. 0541/956034-957884
Fax 0541/956341

47842 S. GIOVANNI IN M. (RN)
e-mail: mtma@mtmarchetti.com
http://www.mtmarchetti.com

PRODUZIONE MODULI ROTANTI



PAGINA NKM336-3-00

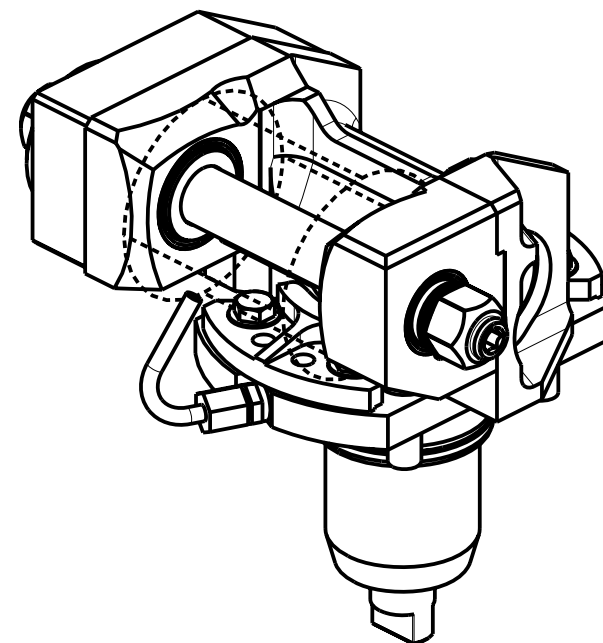
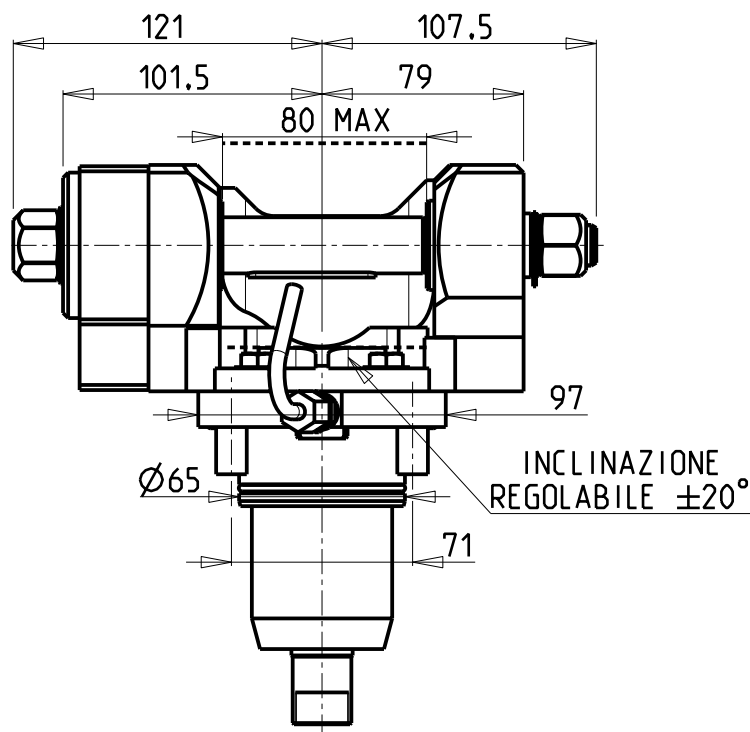
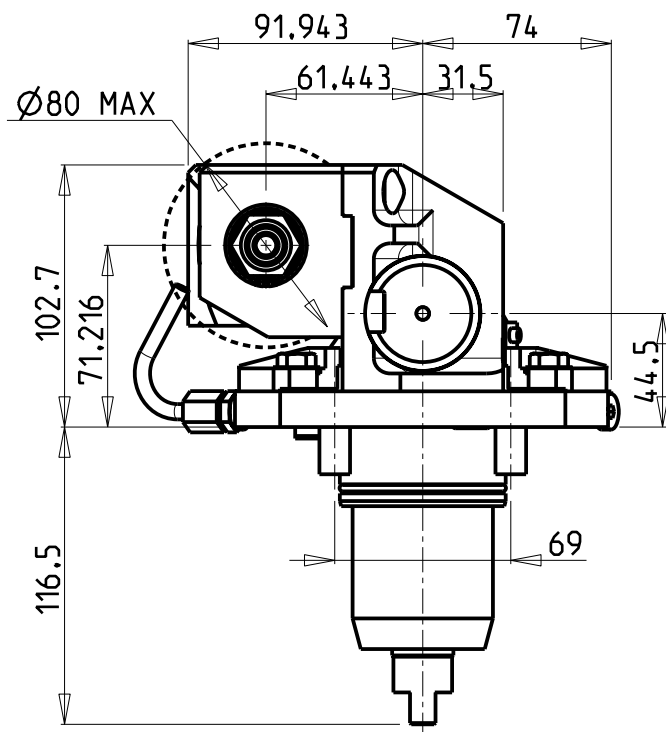

DOTAZIONI - SUPPLIED WITH - AUSSTATTUNG

- | mm / inch | |
|-----------|-----------------------------|
| | - N°1 ALBERO + DISTANZIALI |
| | - N°1 SHAFT + SPACER |
| | - N°1 DORN + ABSTANDSSTUECK |

PER ALBERI E DISTANZIALI VEDI PAG. TBL250-1-00
 FOR SHAFT END SPACER SEE PAGE TBL250-1-00
 FUER DORN UND ABSTANDSSTUECK SEITE TBL250-1-00

Cod. MT	I	RPM max	Coppia Max Max Torque Max Drehmoment	Reversibile lato mandrino/contromandrino Reversible sub/main spindle side Umkehrbare Spindel-seite/ Gegenspindel-seite	Lubrificazione est. Ext. coolant Aussenkuehlung	D (mm)	D (Inch)	CHIAVI INCLUSE Keys included Schluessel inbegriffen		
								CHUB13	CHUB24	CHESL08
NKM0311100	1:1	6000	60Nm	X	X	16-22-27-32	3/4"-1"-1 1/4"	CHUB13	CHUB24	CHESL08
NKM0312100	2:1	3000	80Nm	X	X	16-22-27-32	3/4"-1"-1 1/4"	CHUB13	CHUB24	CHESL08

NAKAMURA-TOME

WT300 - SC300 - SUPER NTX - SUPER NTXL - TW20M/MY/MM/MMY/MYY 12 ST. - TW30M/MY/MM/MMY/MYY 16 ST.

MODULO MOTORIZZATO PORTACREATORE

Driven gear hobber

Angetriebenes Zahnradwaelzfraes-Werkzeug

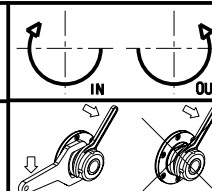

M.T. srl

Via Casino Albini 480
 Tel. 0541/956034-957884
 Fax 0541/956341

47842 S. GIOVANNI IN M. (RN)
 e-mail: mtma@mtmarchetti.com
 http://www.mtmarchetti.com

PRODUZIONE MODULI ROTANTI



PAGINA NKM340-3-00

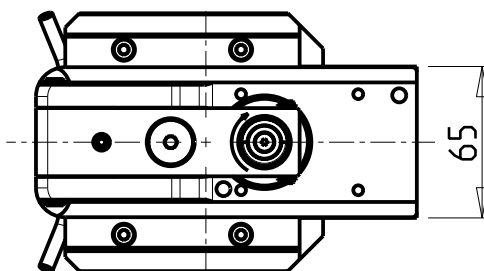
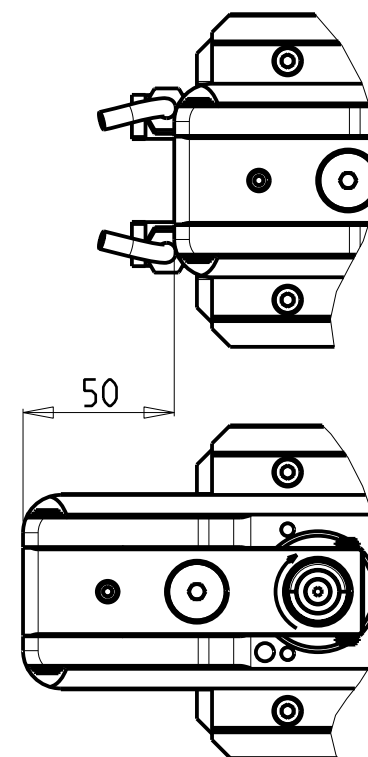
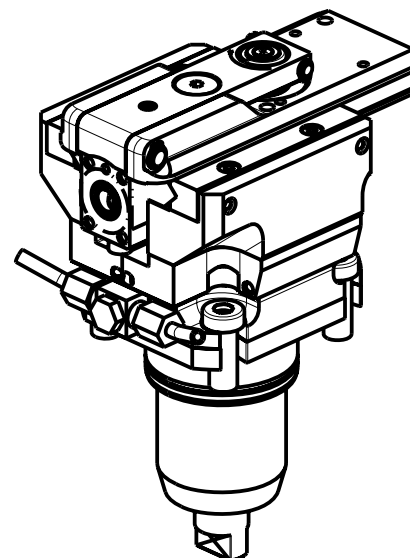
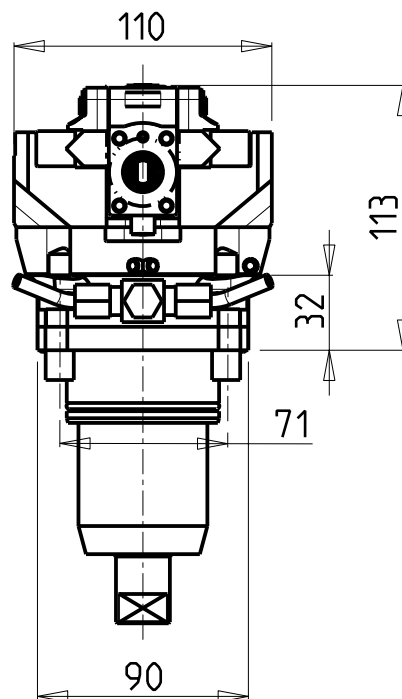
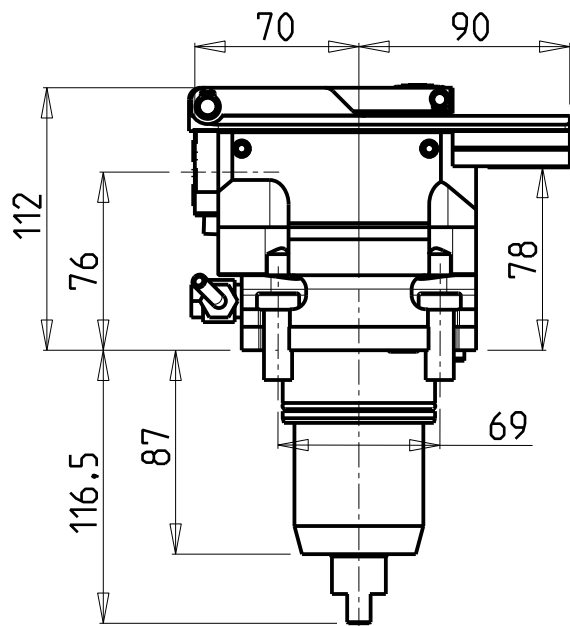

PER UTENSILI STOZZATORI VEDI PAG. TBL400-1-00
 FOR DRIVEN SLOTTING TOOL CUTTING-TOOLS SEE PAGE TBL400-1-00
 FÜR NUTENSTOSS-WERKZEUG SCHNEIDWERKZEUGE SIEHE SEITE TBL400-1-00

Cod. MT	I	RPM MAX	Reversibile lato mandrino/contromandrino Reversible sub/main spindle side Umkehrbare Spindel-seite/ Gegenspindel-seite	Lubr. esterna Ext. coolant Aussenkuehlung
NKM0930100	4:1	2000	X	X

NEW

NAKAMURA-TOME

WT300 - SC300 - SUPER NTX - SUPER NTXL - TW20M/MY/MM/MMY/MYY 12 ST. - TW30M/MY/MM/MMY/MYY 16 ST.

MODULO MOTORIZZATO STOZZATORE

Slotting driven tool

Keilnutenstossmaschine

M.T. srl

Via Casino Albini 480
 Tel. 0541/956034-957884
 Fax 0541/956341
 47842 S. GIOVANNI IN M. (RN)
 e-mail: mtma@mtmarchetti.com
 http://www.mtmarchetti.com

PRODUZIONE MODULI ROTANTI



PAGINA NKM360-3-00

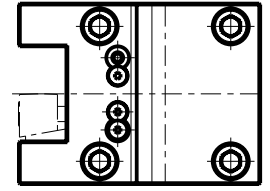
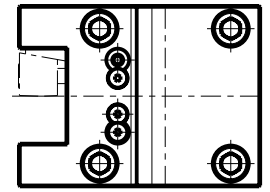
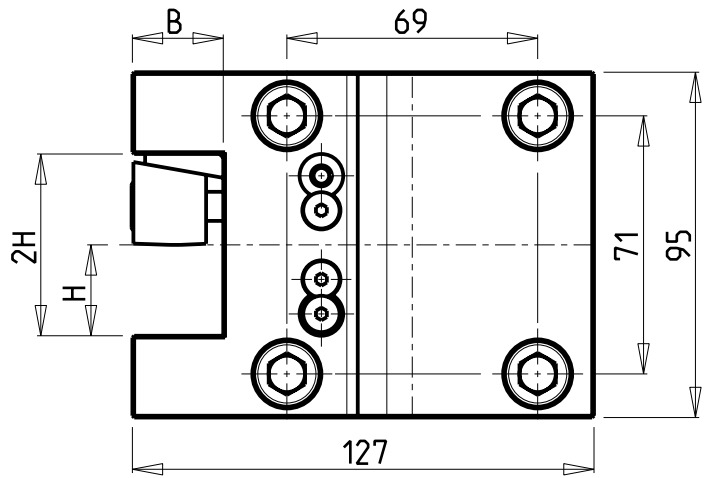
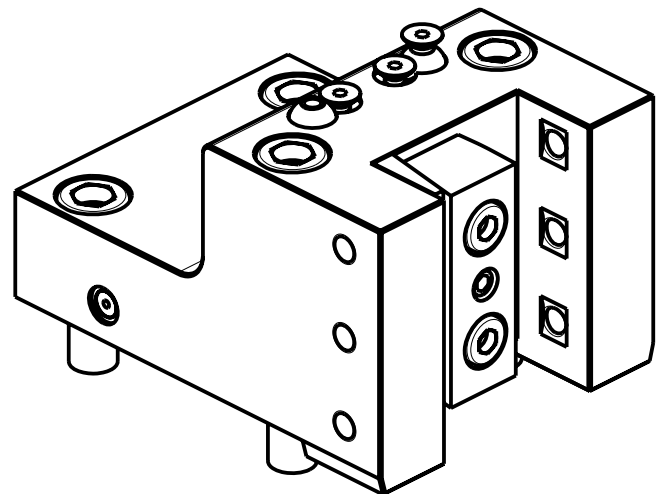
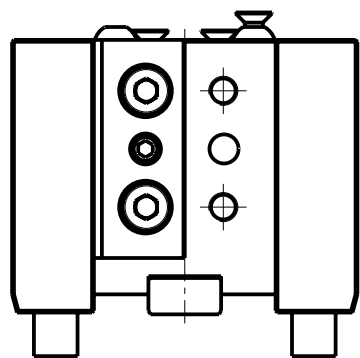
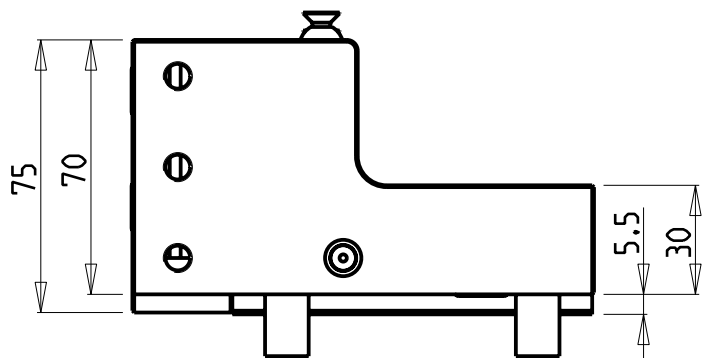

Cod. MT	N°Utensili N°Tools N°Werkzeuge	Reversibile lato mandrino/Contromandrino Reversible sub/main spindle side Umkehrbare Spindel-seite/ Gegenspindel-seite	B	H
NKM0512500	1/2	X	25	25

NAKAMURA-TOME

WT300 - SC300 - SUPER NTX - SUPER NTXL - TW20M/MY/MM/MMY/MYY 12 ST. - TW30M/MY/MM/MMY/MYY 16 ST.

PORTAUTENSILE RADIALE SINGOLO
Radial single static tool
Radial Single-Werkzeughalter

M.T. srl
Via Casino Albini 480
Tel. 0541/956034-957884
Fax 0541/956341
47842 S. GIOVANNI IN M. (RN)
e-mail: mtma@mtmarchetti.com
http://www.mtmarchetti.com

PRODUZIONE MODULI ROTANTI

PAGINA NKM423-3-00

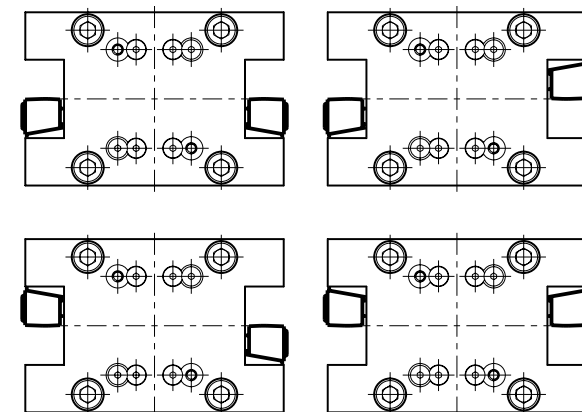
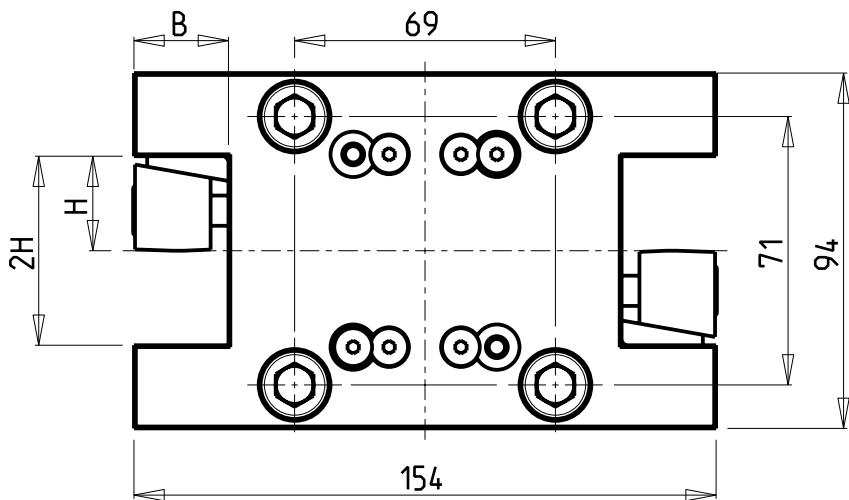
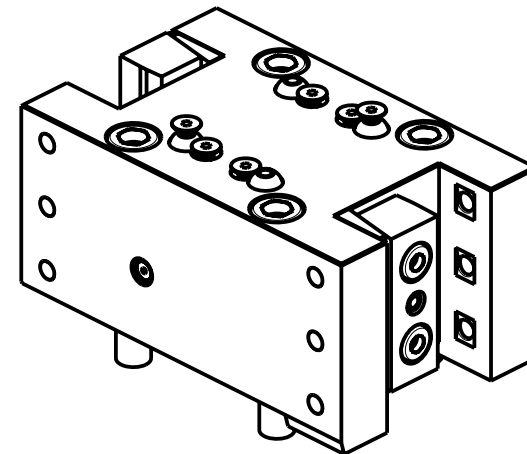
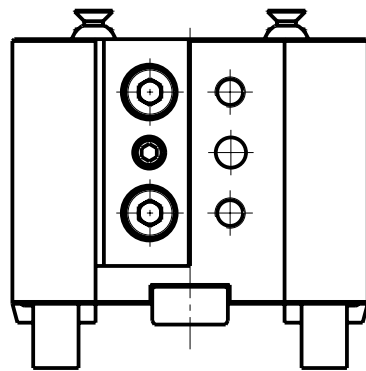
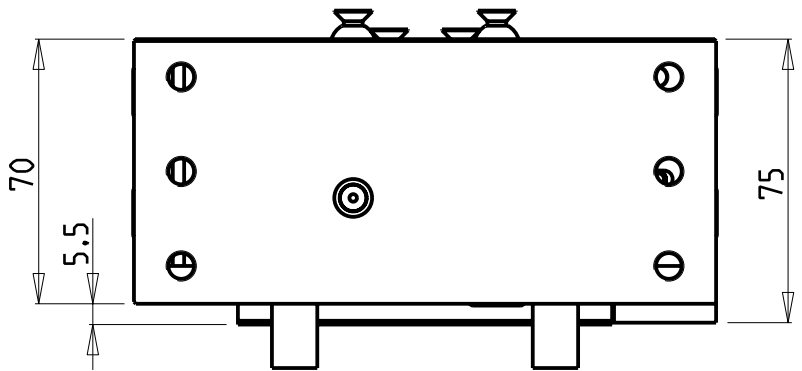

Cod. MT	N°Utensili N°Tools N°Werkzeuge	Reversibile lato mandrino/contromandrino Reversible sub/main spindle side Umkehrbare Spindel-seite/ Gegenspindel-seite	B	H
NKM0532500	2	X	25	25

NAKAMURA-TOME

WT300 - SC300 - SUPER NTX - SUPER NTXL - TW20M/MY/MM/MMY/MYY 12 ST. - TW30M/MY/MM/MMY/MYY 16 ST.

PORTAUTENSILE RADIALE DOPPIO

Radial double static tool

Radial Doppel-Werkzeughalter

M.T. srl

Via Casino Albini 480
Tel. 0541/956034-957884
Fax 0541/956341
47842 S. GIOVANNI IN M. (RN)
e-mail: mtma@mtmarchetti.com
http://www.mtmarchetti.com

PRODUZIONE MODULI ROTANTI



PAGINA NKM453-3-00

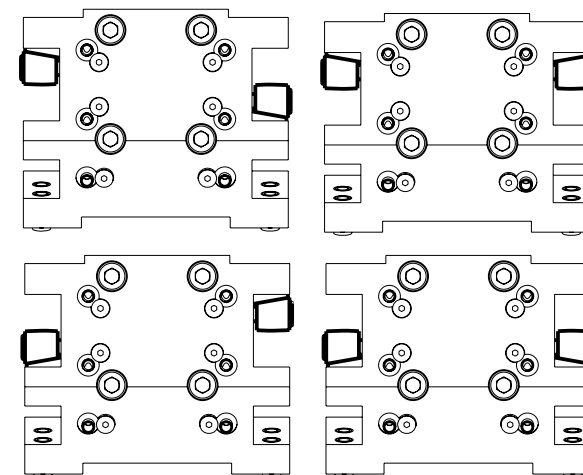
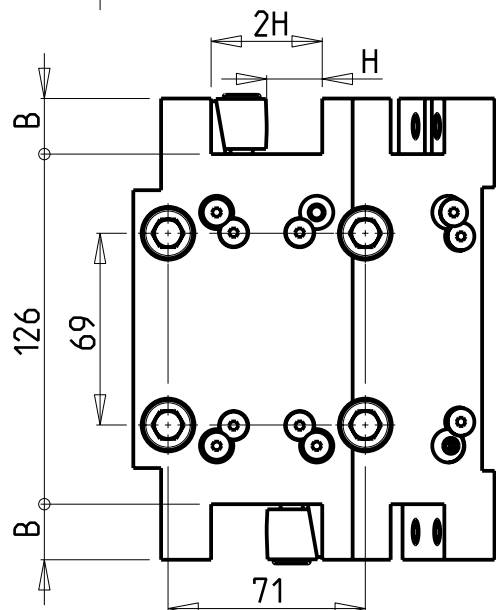
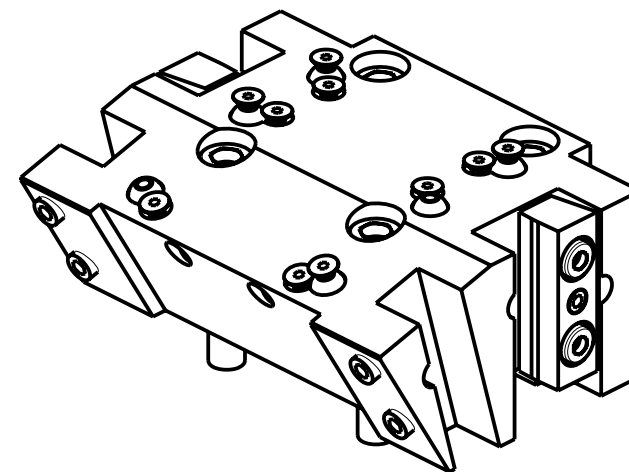
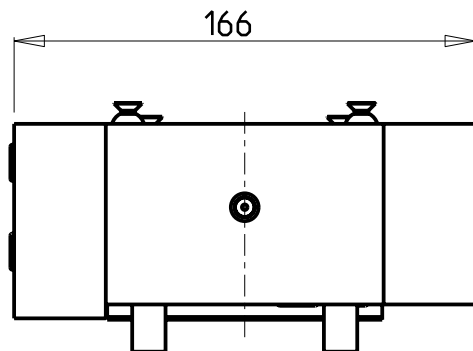
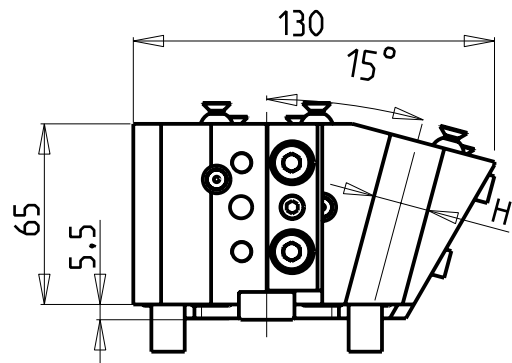

Cod. MT	N°Utensili N° Tools N° Werkzeuge	Reversibile lato mandrino/contromandrino Reversible sub/main spindle side Umkehrbare Spindel-seite/ Gegenspindel-seite	B	H
NKM0572000	4	X	20	20

NAKAMURA-TOME

MOD: WT300 SC300 TW20 SUPERNTX TW20M/MY/MM/MMY/MYY 12 ST. TW30M/MY/MM/MMY/MYY 16 ST.

PORTAUTENSILE RADIALE MULTIPLO

Radial multiple static tool

Radial Mehrfach-Halter

M.T. srl

Via Casino Albini 480
Tel. 0541/956034-957884
Fax 0541/956341
47842 S. GIOVANNI IN M. (RN)
e-mail: mtma@mtmarchetti.com
http://www.mtmarchetti.com

PRODUZIONE MODULI ROTANTI



PAGINA NKM470-3-00

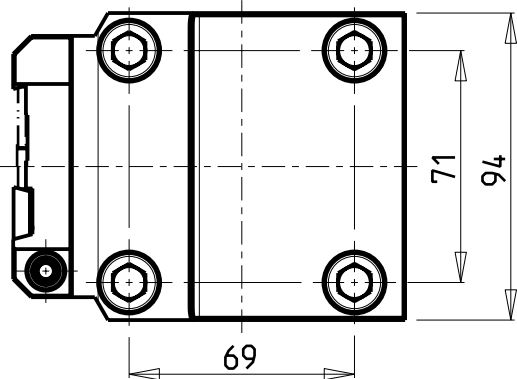
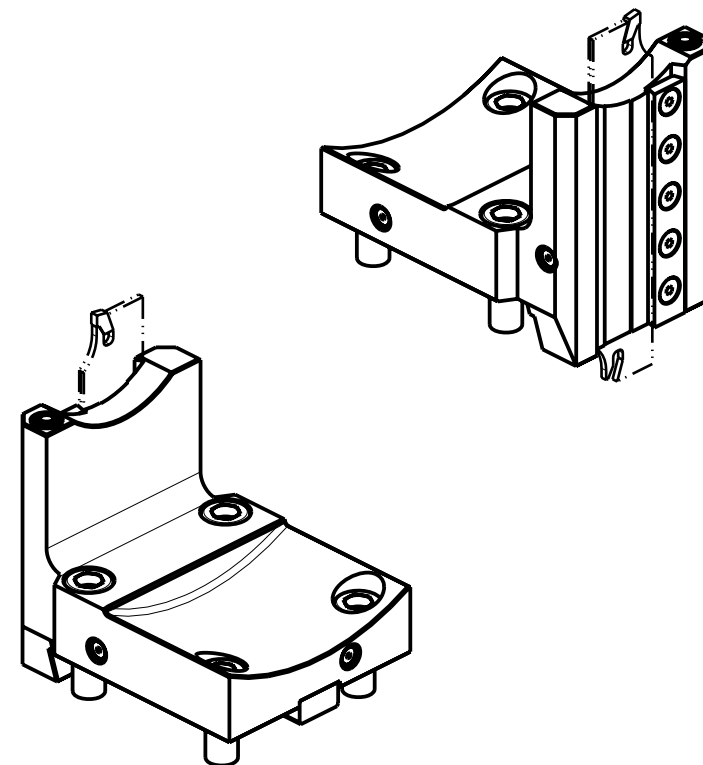
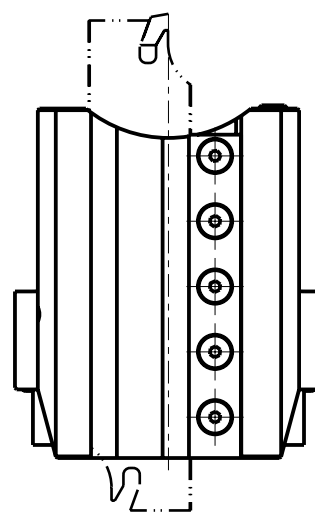
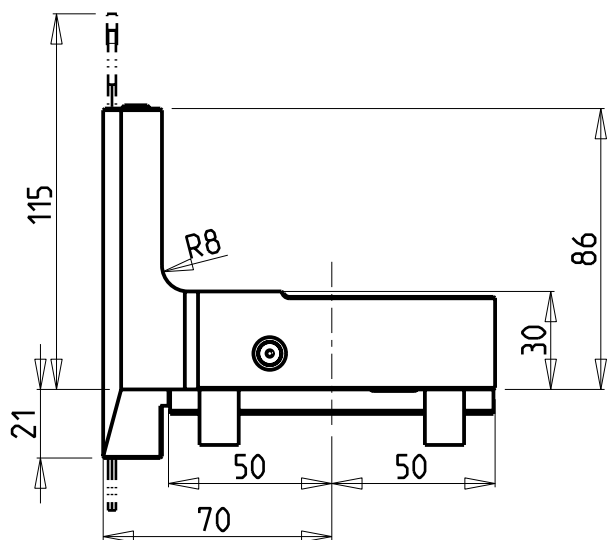
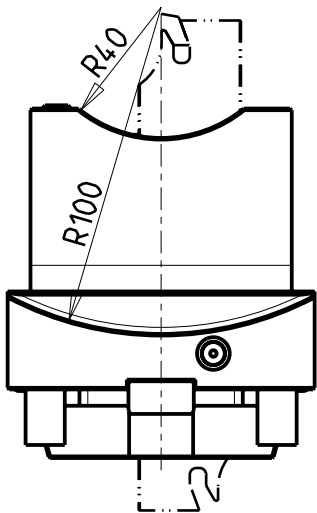

DOTAZIONI - SUPPLIED WITH - AUSSTATTUNG

N°1 - LAMA - BLADE - KLINGE ISCAR H=32 Sp. 3/4mm
(KENNAMETAL OPTIONAL)

N°10 - INSERTI - INSERTS - EINLAGEN

N°1 - CHIAVE A T PER MONTAGGIO INSERTI
- T-WRENCH FOR INSERT SET UP
- T-SCHLUESSEL FUER EINSATZSTUECK-MONTAGE

Cod. MT	N°Utensili N°Tools N°Werkzeuge	Reversibile lato mandrino/contromandrino Reversible sub/main spindle side Umkehrbare Spindel-seite/ Gegenspindel-seite
NKM0580132	1	X

NAKAMURA-TOME

WT300 - SC300 - SUPER NTX - SUPER NTXL - TW20M/MY/MM/MMY/MYY 12 ST. - TW30M/MY/MM/MMY/MYY 16 ST.

PORTAUTENSILE RADIALE PER LAMA

Radial blade holder

Radial Abstechhalter

M.T. srl

Via Casino Albini 480
Tel. 0541/956034-957884
Fax 0541/956341
47842 S. GIOVANNI IN M. (RN)
e-mail: mtma@mtmarchetti.com
http://www.mtmarchetti.com

PRODUZIONE MODULI ROTANTI



PAGINA NKM510-3-00

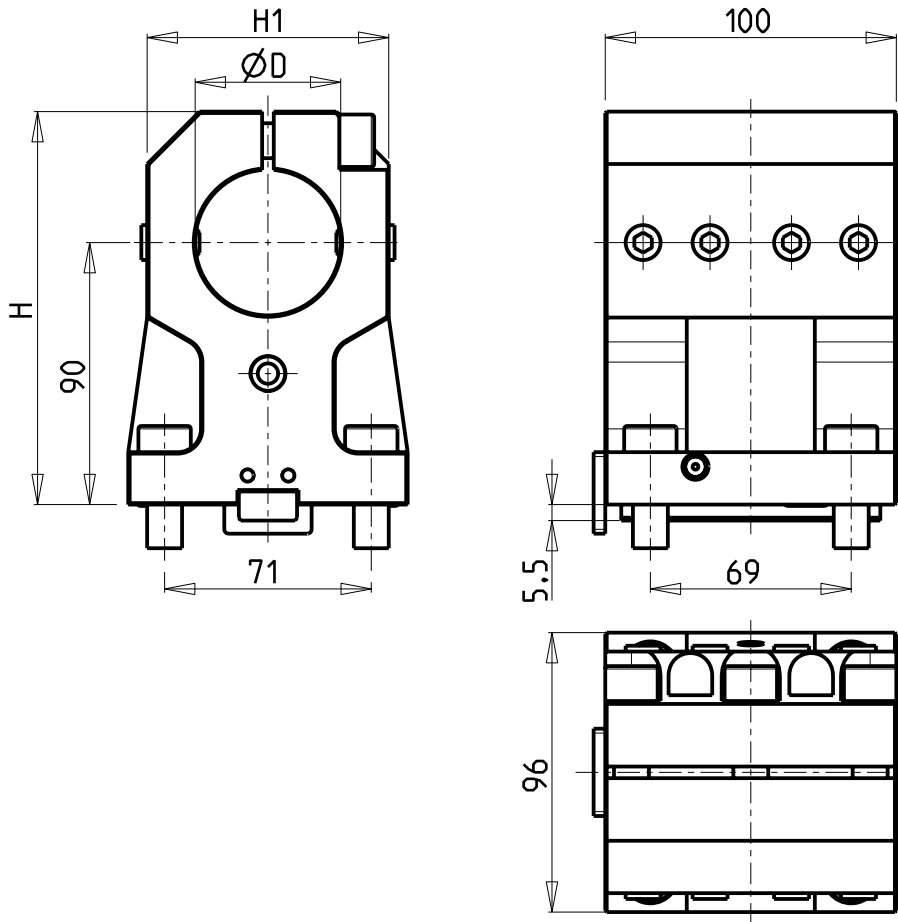

ATTENZIONE - ATTENTION - ACHTUNG

- FINO AD ESAURIMENTO SCORTE
- clearance sale
- solange vorrat

ATTENZIONE - ATTENTION - ACHTUNG

- Verificare la tabella sottostante per possibile interferenza su alcuni modelli di macchine
- Please check the table below for possible interferences on some machine models
- Die untenstehende tabelle unbedingt auf eventuelle interferenzen auf einigen maschinen modellen überprüfen

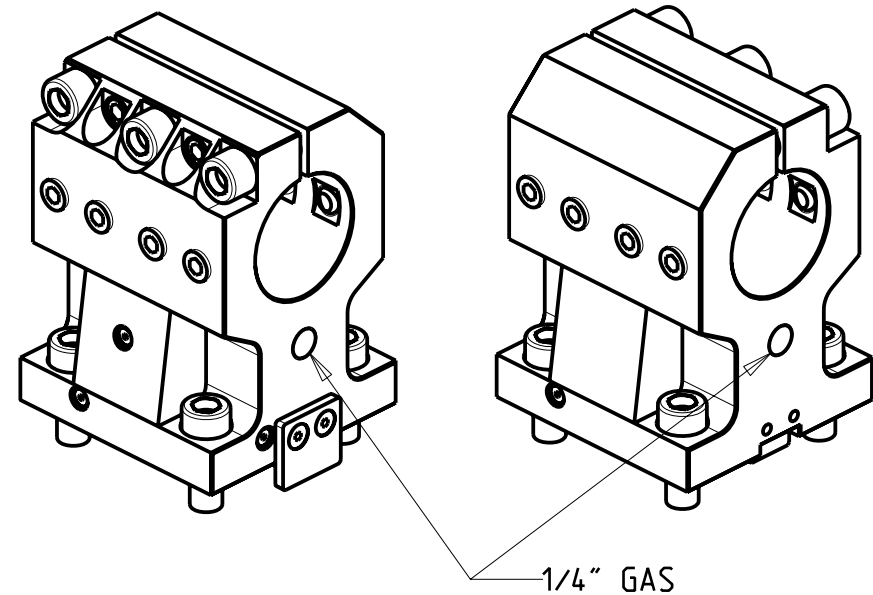

Cod. MT	N°Utensili N°Tools N°Werkzeuge	Reversibile lato mandrino/contromandrino Reversible sub/main spindle side Umkehrbare Spindel-seite/ Gegenspindel-seite	Lubrificazione est. Ext. coolant Aussenkuehlung	Misure Dimensions Masse	D	H	H1
NKM0474000	1	X	X	mm	40	130	73
NKM0475000	1	X	X	mm	50	135	83

PER BOCCOLE DI RIDUZIONE VEDI PAG. TBL150-1-00
FOR REDUCING BUSHINGS SEE PAGE TBL150-1-00
FÜR REDUZIERBUCHSE SIEHE SEITE TBL150-1-00

NAKAMURA-TOME

WT300 - SC300 - SUPER NTX - SUPER NTXL - TW20M/MY/MM/MMY/MYY 12 ST. - TW30M/MY/MM/MMY/MYY 16 ST.

PORTAUTENSILE ASSIALE PER BARENO Ø40mm / Ø50mm H=90mm

Axial single boring bar holder Ø40mm / Ø50mm H=90mm

Axial Bohrhälter Ø40mm / Ø50mm H=90mm.

M.T. srl

Via Casino Albini 480
Tel. 0541/956034-957884
Fax 0541/956341
47842 S. GIOVANNI IN M. (RN)
e-mail: mtma@mtmarchetti.com
http://www.mtmarchetti.com

PRODUZIONE MODULI ROTANTI



PAGINA NKM610-3-20

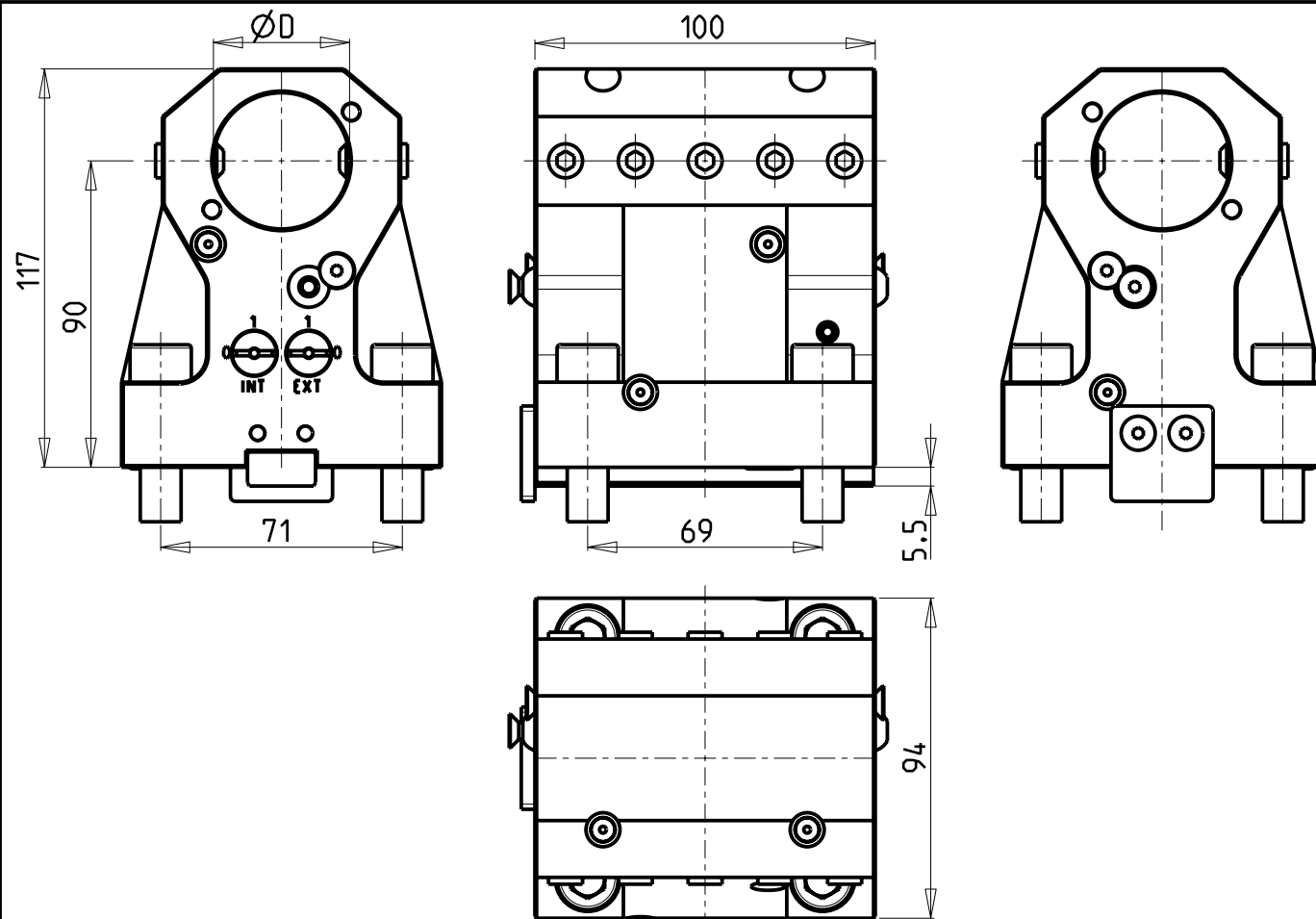

KIT ADDUZIONE INTERNA (OPZIONALE)
 KIT FOR INTERNAL COOLANT (OPTIONAL)
 KIT FUER INTERNE KUEHLMITTELZUFUHR (OPTIONAL)
 Ø40 cod. KIT1000018
 Ø32 cod. KIT1000001

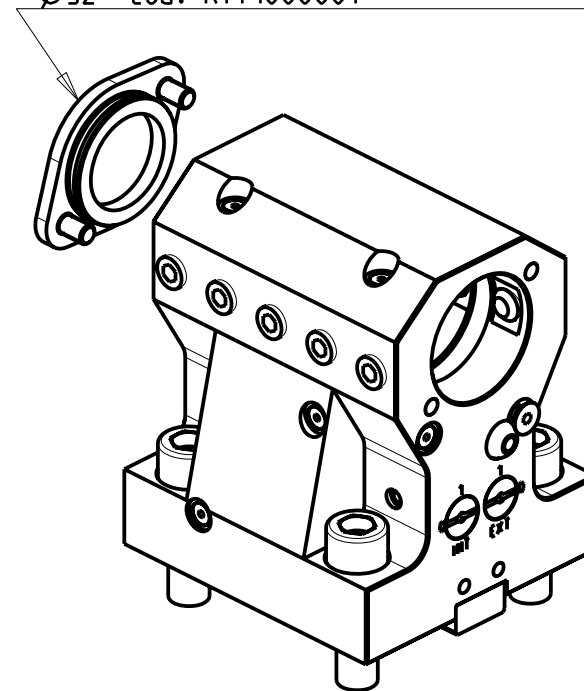

Cod. MT	N°Utensili N° Tools N° Werkzeuge	Reversibile lato mandrino/contromandrino Reversible sub/main spindle side Umkehrbare Spindel-seite/ Gegenspindel-seite	Lubrificazione int. opzionale Coolant through optional Innenkuehlung Optional	Lubrificazione est. Ext. coolant Aussenkuehlung	D
NKM0544000	1	X	X	X	40
NKM0543200	1	X	X	X	32

PER BOCCOLE DI RIDUZIONE VEDI PAG. TBL150-1-00
 FOR REDUCING BUSHINGS SEE PAGE TBL150-1-00
 FÜR REDUZIERBUCHSE SIEHE SEITE TBL150-1-00

NAKAMURA-TOME

WT300 - SC300 - SUPER NTX - SUPER NTXL - TW20M/MY/MM/MMY/MYY 12 ST. - TW30M/MY/MM/MMY/MYY 16 ST.

PORTAUTENSILE ASSIALE PER BARENO Ø40mm / Ø32mm H=90mm

Axial single boring bar holder Ø40mm / Ø32mm H=90mm

Axial Bohrhälter Ø40mm / Ø32mm H=90mm

M.T. srl

Via Casino Albini 480
 Tel. 0541/956034-957884
 Fax 0541/956341
 47842 S. GIOVANNI IN M. (RN)
 e-mail: mtma@mtmarchetti.com
 http://www.mtmarchetti.com

PRODUZIONE MODULI ROTANTI



PAGINA NKM630-3-10

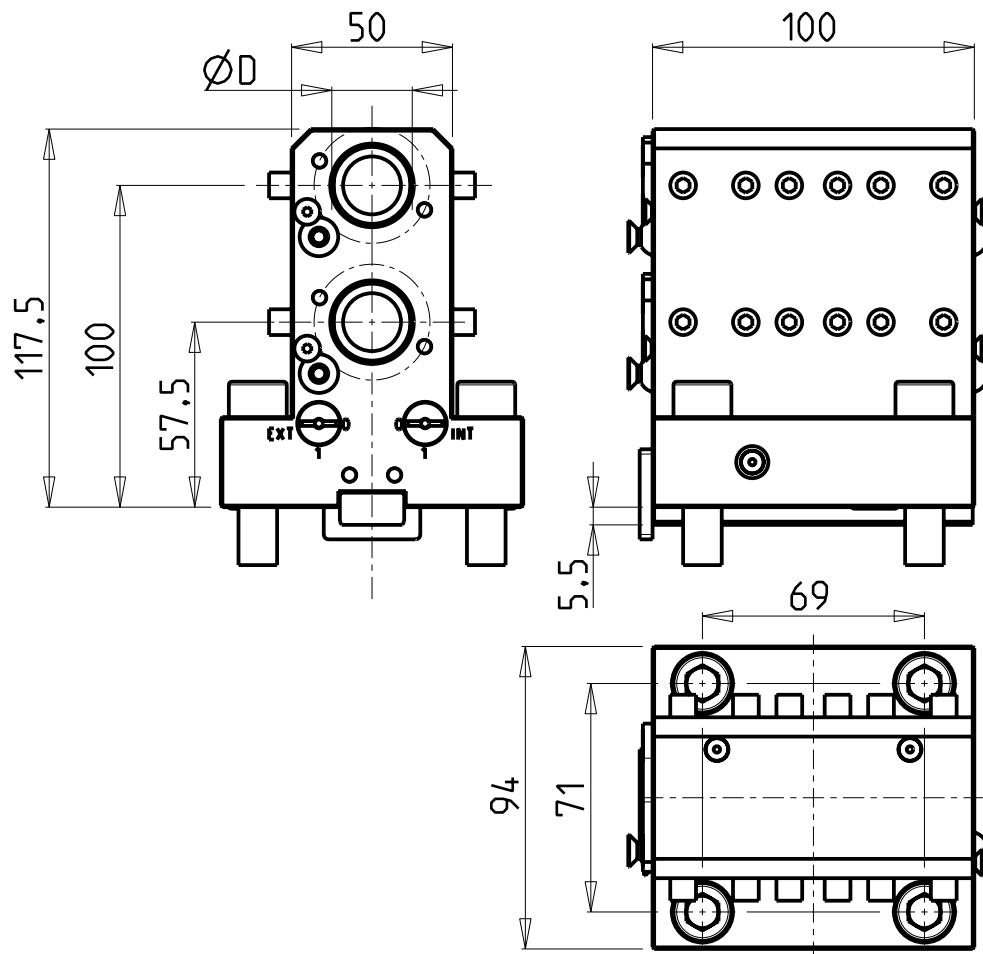

KIT ADDUZIONE INTERNA (OPZIONALE)
 KIT FOR INTERNAL COOLANT (OPTIONAL)
 KIT FUER INTERNE KUEHLMITTELZUFUHR (OPTIONAL)
 Ø25-Ø1" cod. KIT1000006

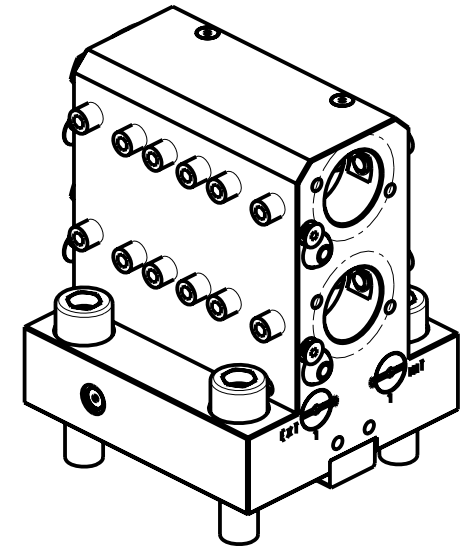
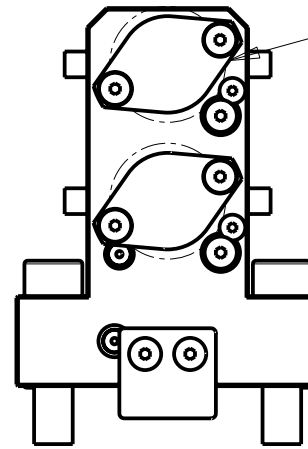

PER BOCCOLE DI RIDUZIONE VEDI PAG. TBL150-1-00
 FOR REDUCING BUSHINGS SEE PAGE TBL150-1-00
 FÜR REDUZIERBUCHSE SIEHE SEITE TBL150-1-00

Cod. MT	N°Utensili N°Tools N°Werkzeuge	Reversibile lato mandrino/contromandrino Reversible sub/main spindle side Umkehrbare Spindel-seite/ Gegenspindel-seite	Lubrificazione int. opzionale Coolant through optional Innenkuehlung Optional	Lubrificazione est. Ext. coolant Aussenkuehlung	Misure Dimensions Masse	Ø
NKM0552500	2	X	X	X	mm	25

NAKAMURA-TOME

MOD:WT300 SC300 TW20 SUPERNTX TW20M/MY/MM/MMY/MYY 12 ST. TW30M/MY/MM/MMY/MYY 16 ST.

PORTAUTENSILE ASSIALE PER BARENO 2 POSIZIONI Ø25mm

Axial double boring bar holder Ø25mm

Axial Bohrhälter 2 Positionen Ø25mm

M.T. srl

Via Casino Albini 480
 Tel. 0541/956034-957884
 Fax 0541/956341
 47842 S. GIOVANNI IN M. (RN)
 e-mail: mtma@mtmarchetti.com
 http://www.mtmarchetti.com

PRODUZIONE MODULI ROTANTI



PAGINA NKM864-3-00

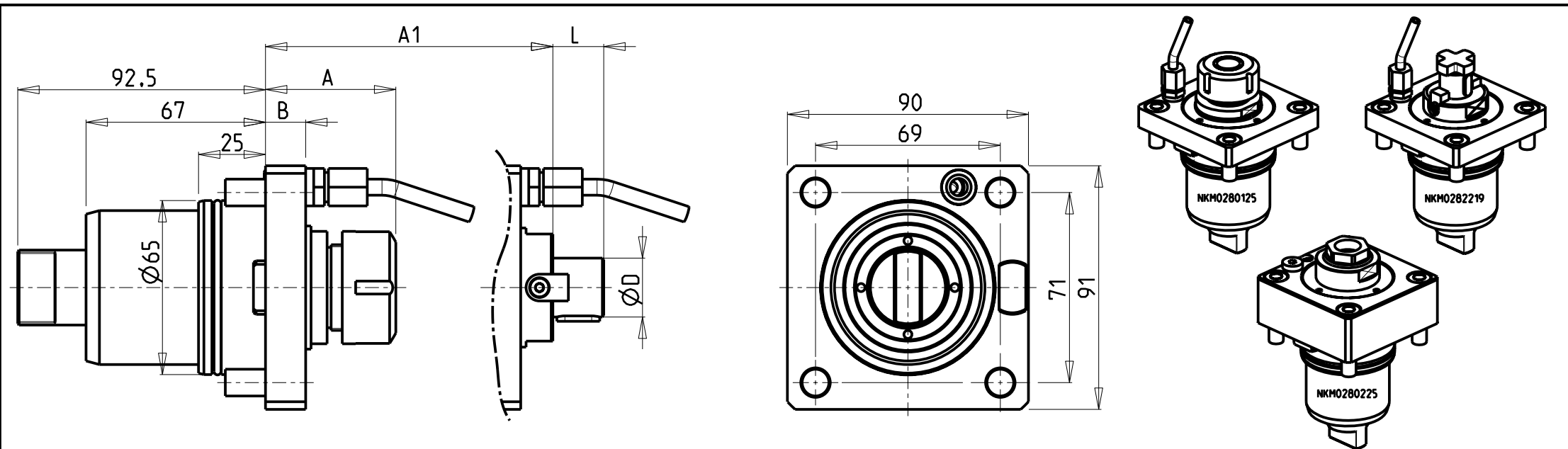

Cod. MT	Cod. NAKAMURA	Mandrino Spindel Spindel	I	RPM	Coppia Max Max Torque Max Drehmoment	Lubrificazione int. Coolant through Innenkuhlung	Lubrificazione est. Ext. coolant Ausseinkuehlung	A	A1	B	D	L	CHIAVI NON INCLUSE Keys not included Schlüssel nicht einbegriffen	
NKM0280125	-	ER25	1:1	6000	70Nm		X	48.66	-	15	-	-	CHUB42	CHSTER25
NKM0280132	G31330	ER32	1:1	6000	70Nm		X	52.16	-	15	-	-	CHUB40	CHSTER32
NKM0280332	-	ER32	1:1	6000	70Nm	P=30bar	X	71.66	-	35	-	-	CHUB40	CHSTER32
NKM0280225	-	ER A 25	1:1	6000	70Nm	P=30bar	X	59.03	-	35	-	-	CHUB40	CHUB27
NKM0280232	-	ER A 32	1:1	6000	70Nm	P=30bar	X	67.53	-	35	-	-	CHUB46	CHUB32
NKM0281617	-	Ø16x17	1:1	6000	70Nm		X	-	25	15	16	17	CHUB42	CH_VTCROCE_M08
NKM0282219	G31380	Ø22x19	1:1	6000	70Nm		X	-	27	15	22	19	CHUB40	CH_VTCROCE_M10
NKM0282721	-	Ø27x21	1:1	6000	70Nm		X	-	28	15	27	21	CHUB40	CH_VTCROCE_M12
NKM0281919	-	Ø3/4"x3/4"	1:1	6000	70Nm		X	-	25	15	3/4"	3/4"	CHUB42	CH_VTCROCE_M08
NKM0282519	-	Ø1"x19	1:1	6000	70Nm		X	-	29	15	1"	19	CHUB40	CH_VTCROCE_M12

NEW

- Chiave inclusa
- Key included
- Schlüssel einbegriffen

NAKAMURA-TOME

MOD: Super Mill WT150/WT15011/WY250/SC200L - SUPER NTY3 JUMBO

MODULO MOTORIZZATO RADIALE

Radial driven tool

Radial angetriebenes Werkzeug

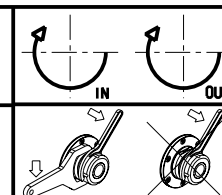

M.T. srl

Via Casino Albini 480
Tel. 0541/956034-957884
Fax 0541/956341
47842 S. GIOVANNI IN M. (RN)
e-mail: mtma@mtmarchetti.com
http://www.mtmarchetti.com

PRODUZIONE MODULI ROTANTI



PAGINA NKM010-4-00

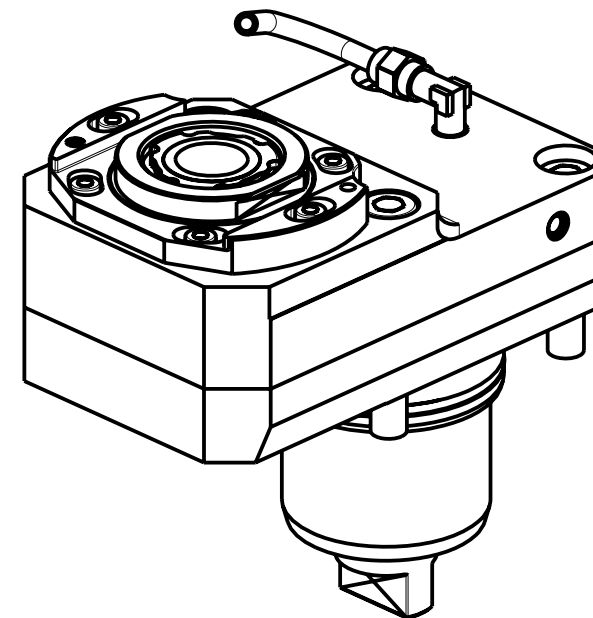
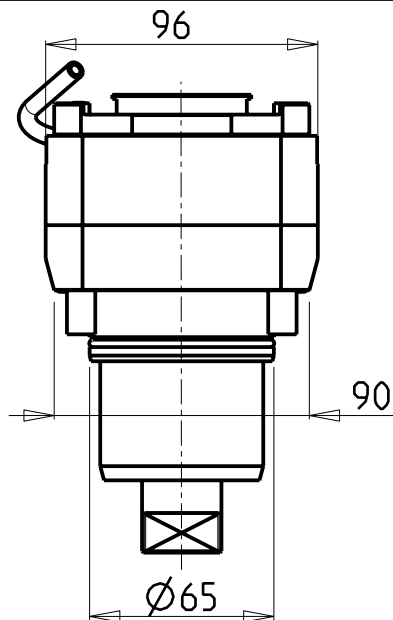
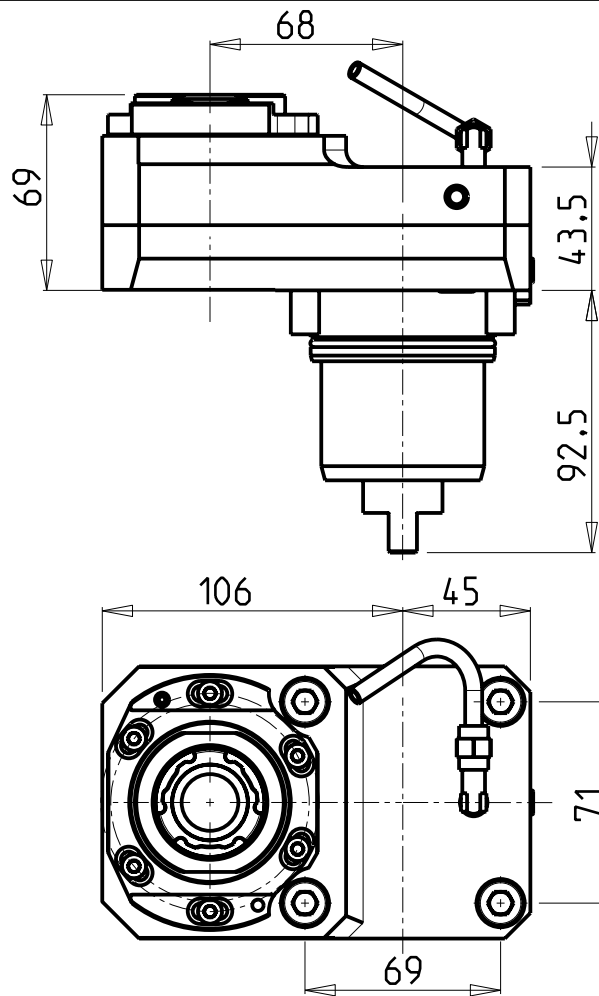

Cod. MT	Mandrino Spindle Spindel	I	RPM	Coppia Max Max Torque Max Drehmoment	Reversibile lato mandrino/contromandrino Reversible sub/main spindle side Umkehrbare Spindel-seite/ Gegenspindel-seite	Lubr.esterna Ext. coolant Aussenkuehlung	CHIAVI NON INCLUSE Keys not included Schluessel nicht einbegriffen		
NKM0752132	ERA32	2:1	3000	70Nm	X	X	CHUB30	CHTAER32ZC	OKU0650004

- Chiave inclusa
- Key included
- Schluessel inbegriffen

NEW

NAKAMURA-TOME

MOD: Super Mill WT150/WT15011/WY250/SC200L - SUPER NTY3 JUMBO

MODULO MOTORIZZATO RADIALE RIDOTTO I=2:1 DISASSATO IN Z 68mm

Radial geared-down I=2:1 driven tool re-directed in Z by 68mm

Radial angetriebenes Werkzeug untersetzt I=2:1 achsversetzt in Z um 68mm

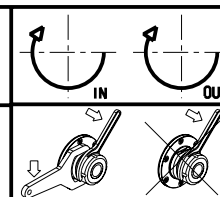

M.T. srl

Via Casino Albini 480
Tel. 0541/956034-957884

Fax 0541/956341

47842 S. GIOVANNI IN M. (RN)

e-mail: mtma@mtmarchetti.com

http://www.mtmarchetti.com

PRODUZIONE MODULI ROTANTI



PAGINA NKM030-4-20

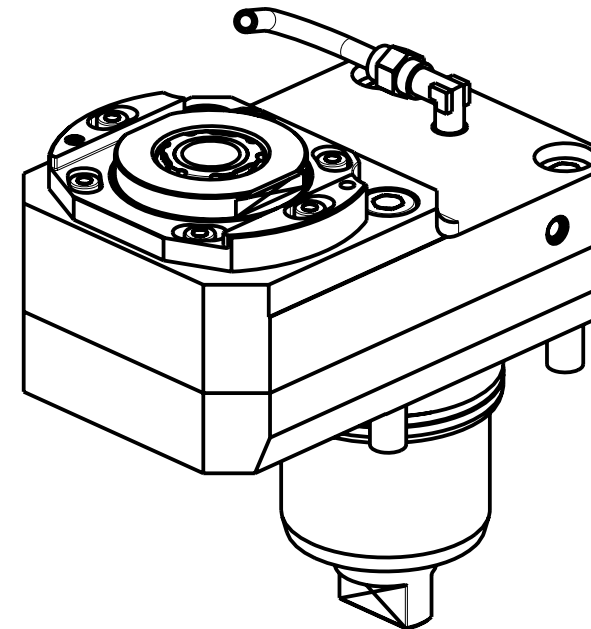
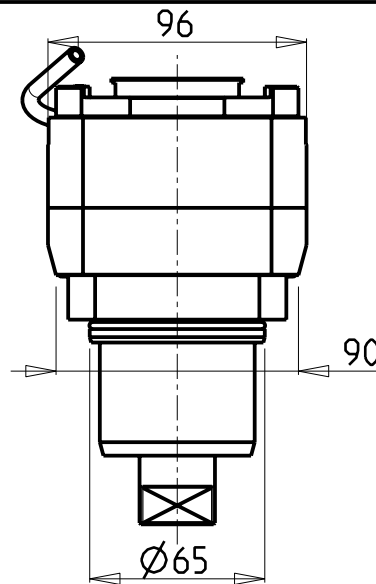
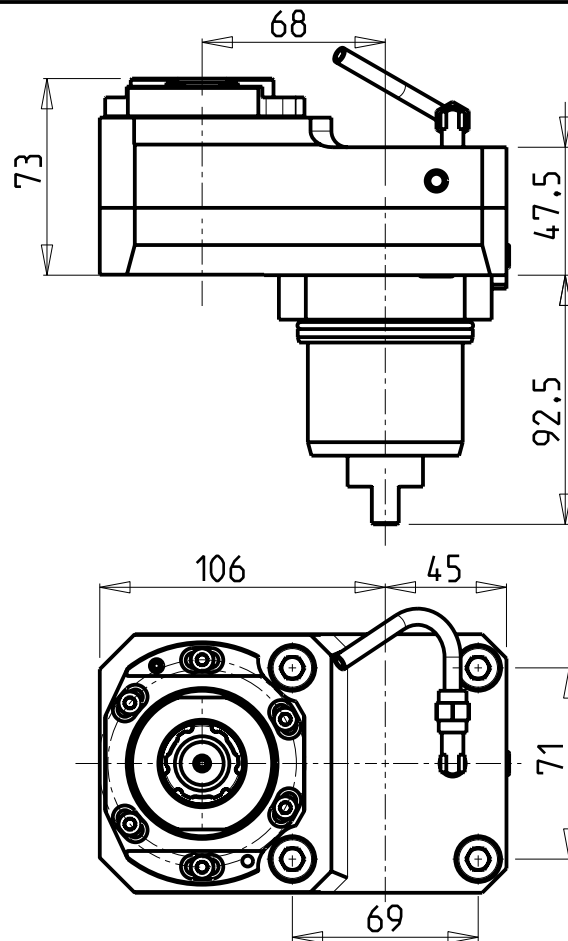

- Chiave inclusa
- Key included
- Schlüssel inbegriffen

Cod. MT	Mandrino Spindle Spindel	I	RPM MAX	Coppia Max Max Torque Max Drehmoment	Reversibile lato mandrino/contromandrino Reversible sub/main spindle side Umkehrbare Spindel- seite/Gegenspindel- seite	Lubr.interna Coolant through Innenkuehlung	Lubrificazione est. Ext. coolant Aussenkuehlung	CHIAVI NON INCLUSE Keys not included Schlüssel nicht einbegriffen			
								CHUB27	CHTAER25ZC	OKU0650004	
NKM0852132	ER A 25	1:2	12000	30Nm	X	-	X	CHUB27	CHTAER25ZC	OKU0650004	NEW
NKM0854225	ER A 25	1:2	12000	30Nm	X	P=70bar	X	CHUB27	CHTAER25ZC	OKU0650004	NEW

NAKAMURA-TOME

MOD: Super Mill WT150/WT15011/WY250/SC200L - SUPER NTY3 JUMBO

MODULO MOTORIZZATO RADIALE MOLTIPLICATO I=1:2 DISASSATO IN Z 68mm

Radial geared-up I=1:2 driven tool re-directed in Z by 68mm

Radial angetriebenes Werkzeug uebersetzt I=1:2 achsversetzt in Z um 68mm

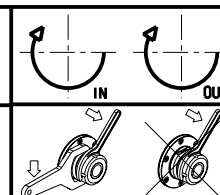

M.T. srl

Via Casino Albini 480
Tel. 0541/956034-957884

Fax 0541/956341

47842 S. GIOVANNI IN M. (RN)

e-mail: mtma@mtmarchetti.com

http://www.mtmarchetti.com

PRODUZIONE MODULI ROTANTI



PAGINA NKM033-4-30

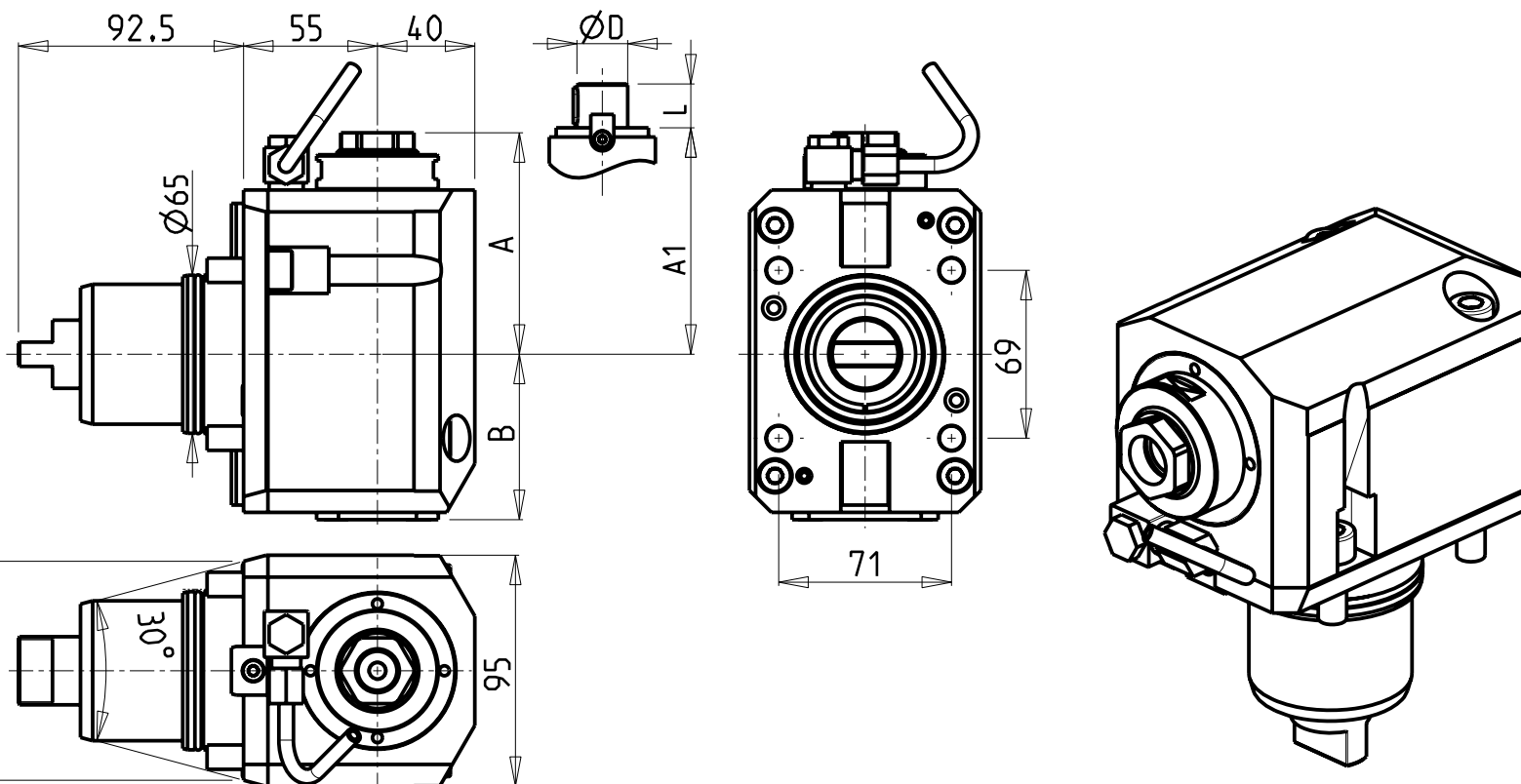

ATTENZIONE - ATTENTION - ACHTUNG

- Per lo smontaggio degli utensili utilizzare sempre la chiave di contrasto come indicato nel manuale d'uso.
- For disassembly of the tools use always the contrast key as mentioned in the user instructions.
- Fuer das Abmontieren der Werkzeuge immer den Gegenschlüssel benutzen wie in der Bedienungsanleitung erwäehnt.

- Chiave inclusa
- Key included
- Schlüssel inbegriffen

Cod. MT	Cod. NAKAMURA	Mandrino Spindle Spindel	I	RPM	Coppia Max Max Torque Max Drehmoment	Reversibile lato mandrino/contromandrino Reversible sub/main spindle side Umkehrbare Spindel-seite/ Gegenspindel-seite	Lubr.interna Coolant through Innenkuehlung	Lubr.esterna Ext. coolant Aus-senkuehlung	A	A1	B	D	L	CHIAVI NON INCLUDE Keys not included Schluessel nicht einbegriffen	
NKM0290125	-	ER A 25	1:1	6000	70Nm	X		X	91.03	-	68	-	-	CHUB46	CHUB27
NKM0290132	G31333	ER A 32	1:1	6000	70Nm	X		X	94.53	-	68	-	-	CHUB46	CHUB32
NKM0290225	-	ER A 25	1:1	6000	70Nm	X	P=70bar	X	91.03	-	91.5	-	-	CHUB46	CHUB27
NKM0290232	G31339	ER A 32	1:1	6000	70Nm	X	P=70bar	X	94.53	-	91.5	-	-	CHUB46	CHUB32
NKM0292219	-	Ø22x19	1:1	6000	70Nm	X		X	-	80	68	22	19	CHUB46	CH_VTCROCE_M10 *

NAKAMURA-TOME
 MOD: Super Mill WT150/W T15011/WY250/SC200L - SUPER NTY3 JUMBO
 MODULO MOTORIZZATO ASSIALE H=55mm
 Axial driven tool H=55mm
 Axial angetriebenes Werkzeug H=55mm

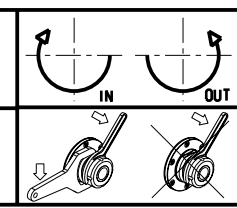

M.T. srl
 Via Casino Albini 480
 Tel. 0541/956034-957884
 Fax 0541/956341
 47842 S. GIOVANNI IN M. (RN)
 e-mail: mtma@mtmarchetti.com
 http://www.mtmarchetti.com

PRODUZIONE MODULI ROTANTI

PAGINA NKM150-4-10

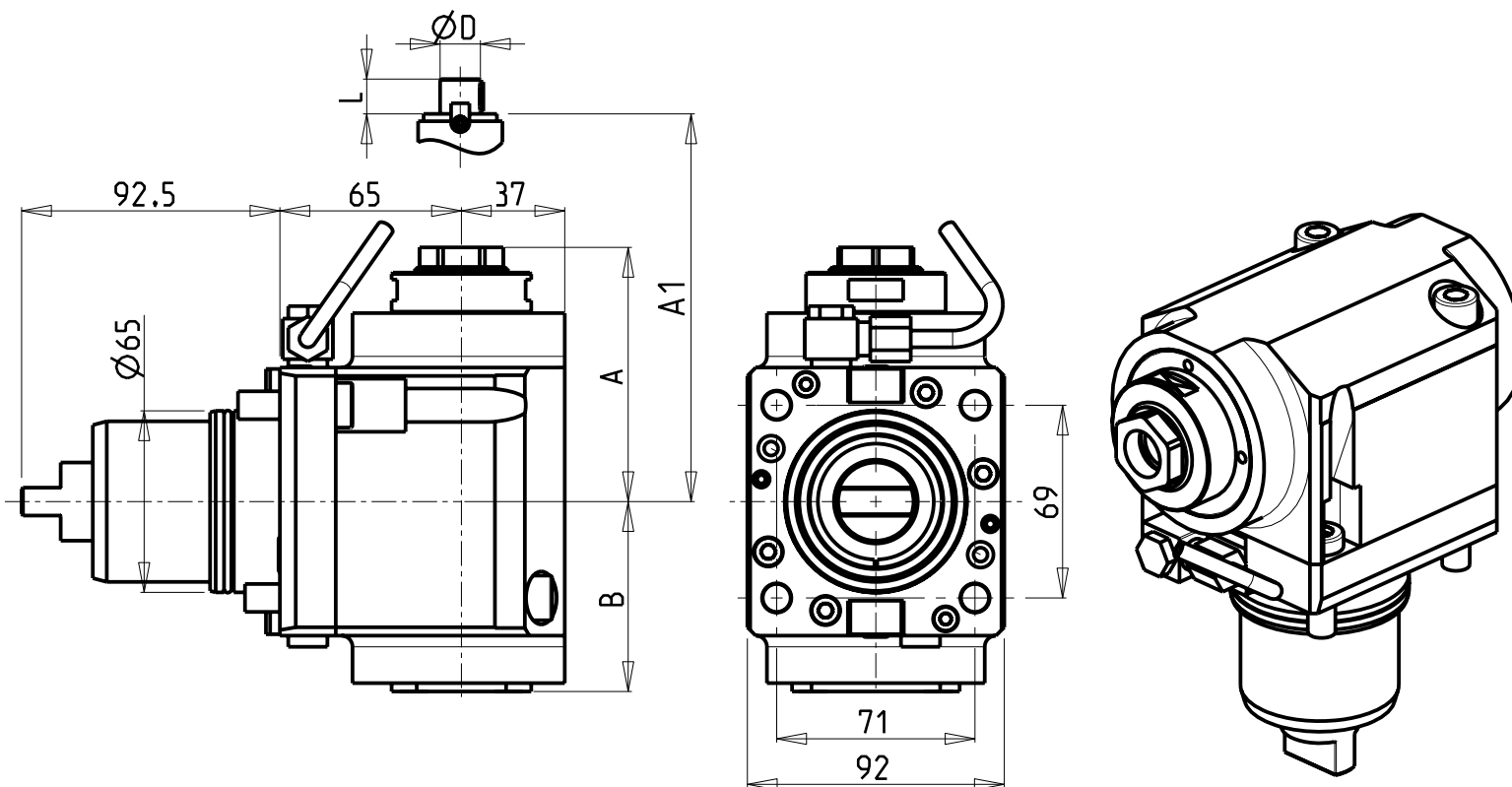

ATTENZIONE - ATTENTION - ACHTUNG

- Per lo smontaggio degli utensili utilizzare sempre la chiave di contrasto come indicato nel manuale d'uso.
- For disassembly of the tools use always the contrast key as mentioned in the user instructions.
- Fuer das Abmontieren der Werkzeuge immer den Gegenschlüssel benutzen wie in der Bedienungsanleitung erwahnt.

ATTENZIONE - ATTENTION - ACHTUNG

- FINO AD ESAURIMENTO SCORTE
- clearance sale
- solange vorrat

Cod. MT	Mandrino Spindle Spindel	I	RPM	Coppia Max Max Torque Max Drehmoment	Reversibile lato mandrino/contromandrino Reversible sub/main spindle side Umkehrbare Spindel-seite/ Gegenspindel-seite	Lubr.interna Coolant through Innenkuehlung	Lubr.esterna Ext. coolant Aussenkuehlung	A	A1	B	CHIAVI NON INCLUSE Keys not included Schluessel nicht einbegriffen	
NKM0610125	ER A 25	1:1	6000	70Nm	X		X	91.03	-	68	CHUB46	CHUB27
NKM0610132	ER A 32	1:1	6000	70Nm	X		X	94.53	-	68	CHUB46	CHUB32
NKM0610225	ER A 25	1:1	6000	70Nm	X	P=70bar	X	91.03	-	91.5	CHUB46	CHUB27
NKM0610232	ER A 32	1:1	6000	70Nm	X	P=70bar	X	94.53	-	91.5	CHUB46	CHUB32
NKM0612219	Ø22x19	1:1	6000	70Nm	X		X	-	80	68	CHUB46	CH_VTCROCE_M10

- Chiave inclusa
- Key included
- Schluessel inbegriffen

NEW

NAKAMURA-TOME

MOD: Super Mill WT150/WT15011/WY250/SC200L - SUPER NTY3 JUMBO

MODULO MOTORIZZATO ASSIALE H=65mm

Axial driven tool H=65mm

Axial angetriebenes Werkzeug H=65mm

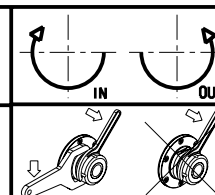

M.T. srl

Via Casino Albini 480
Tel. 0541/956034-957884

Fax 0541/956341

47842 S. GIOVANNI IN M. (RN)
e-mail: mtma@mtmarchetti.com
http://www.mtmarchetti.com

PRODUZIONE MODULI ROTANTI



PAGINA NKM150-4-20

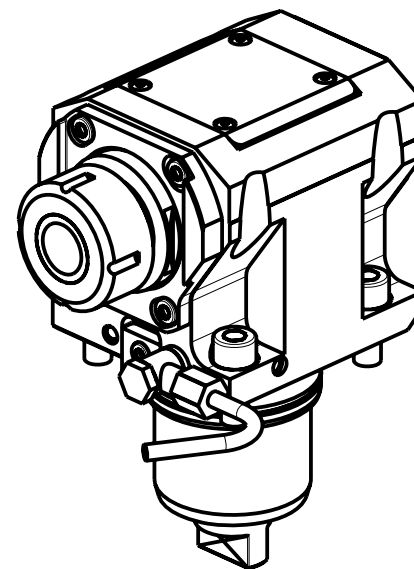
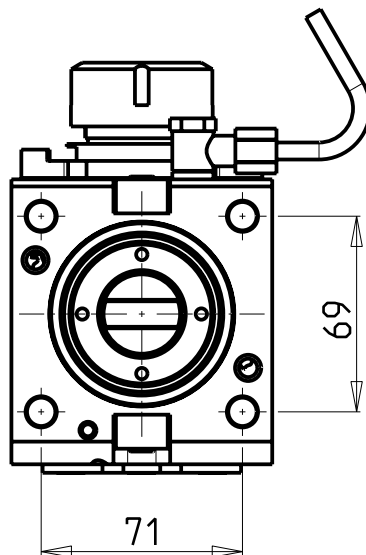
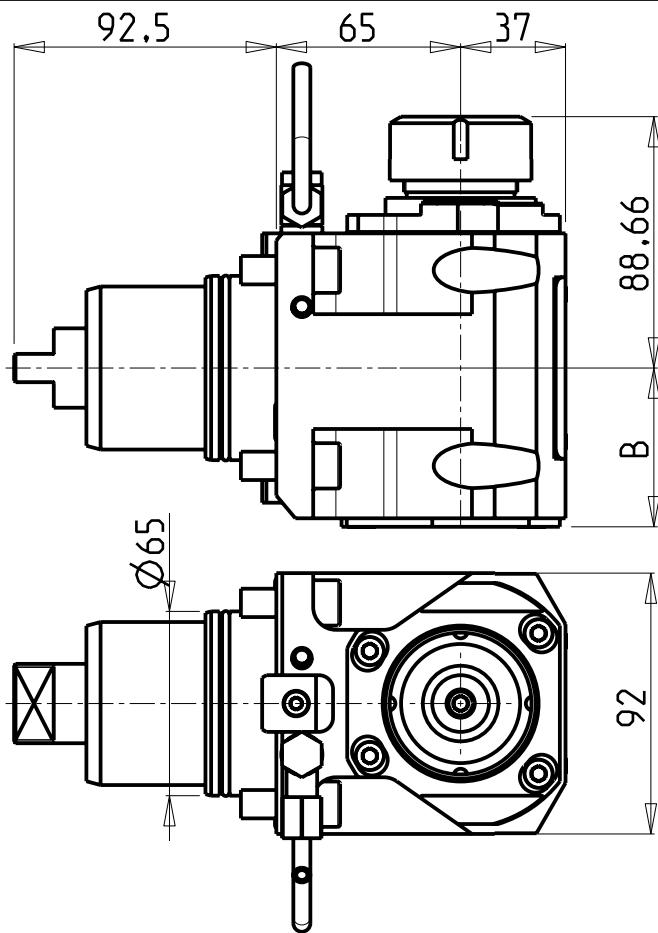

ATTENZIONE - ATTENTION - ACHTUNG

- Per lo smontaggio degli utensili utilizzare sempre la chiave di contrasto come indicato nel manuale d'uso.
- For disassembly of the tools use always the contrast key as mentioned in the user instructions.
- Fuer das Abmontieren der Werkzeuge immer den Gegenschlüssel benutzen wie in der Bedienungsanleitung erwäehnt.

Cod. MT	Mandrino Spindle Spindel	I	RPM	Coppia Max Max Torque Max Drehmoment	Reversibile lato mandrino/contromandrino Reversible sub/main spindle side Umkehrbare Spindel-seite/ Gegenspindel-seite	Lubr.interna Coolant through Innenkuehlung	Lubr.esterna Ext. coolant Aussenkuehlung	B	CHIAVI NON INCLUSE Keys not included Schluessel nicht einbegriffen
NKM0740132	ER32	1:1	6000	70Nm	X		X	56	CHSTER32 OKU0650004
NKM0740232	ER32	1:1	6000	70Nm	X	P=70bar	X	67	CHSTER32 OKU0650004

- Chiave inclusa
- Key included
- Schluessel inbegriffen

NEW

NEW

NAKAMURA-TOME

MOD: Super Mill WT150/WT15011/WY250/SC200L - SUPER NTY3 JUMBO

MODULO MOTORIZZATO ASSIALE H=65mm

Axial driven tool H=65mm

Axial angetriebenes Werkzeug H=65mm

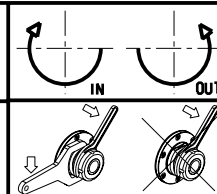

M.T. srl

Via Casino Albini 480
Tel. 0541/956034-957884
Fax 0541/956341

47842 S. GIOVANNI IN M. (RN)
e-mail: mtma@mtmarchetti.com
http://www.mtmarchetti.com

PRODUZIONE MODULI ROTANTI



PAGINA NKM150-4-21

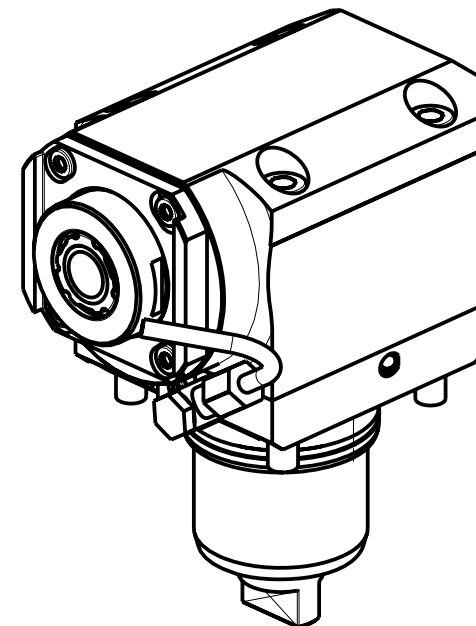
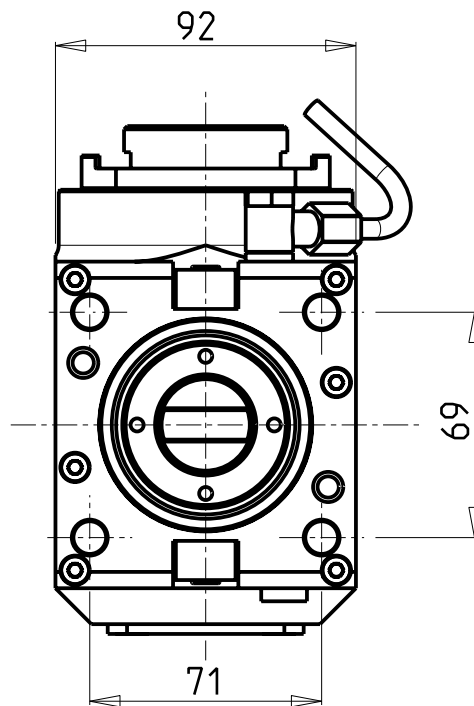
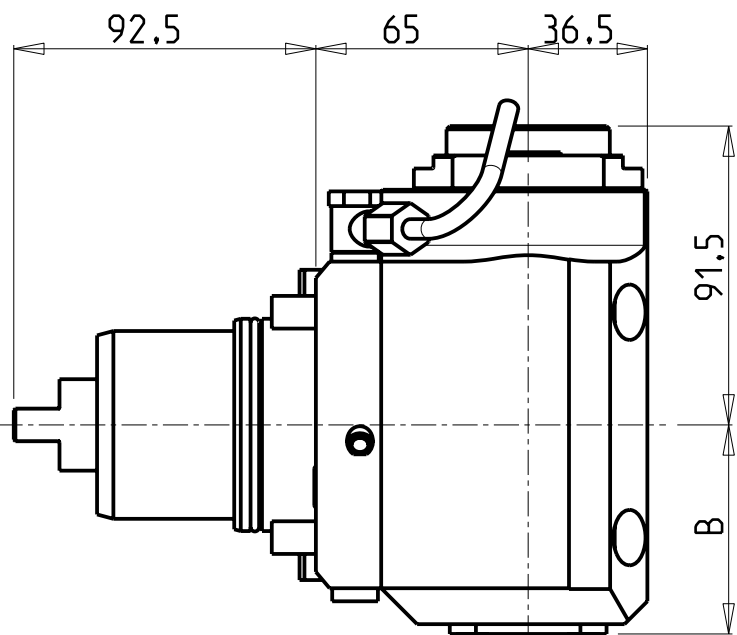

Cod. MT	Mandrino Spindle Spindel	I	RPM	Coppia Max Max Torque Max Drehmoment	Reversibile lato mandrino/contromandrino Reversible sub/main spindle side Umkehrbare Spindel-seite/ Gegenspindel-seite	Lubrificazione int. Coolant through Innenkuehlung	Lubrificazione est. Ext. coolant Aussenkuehlung	B	CHIAVI NON INCLUSE Keys not included Schluessel nicht einbegriffen			
					X		X					
NKM0860325	ER A 25	1:2	12000	30Nm	X		X	64	CHUB27	CHTAER25ZC	OKU0650004	NEW
NKM0860425	ER A 25	1:2	12000	30Nm	X	P=70bar	X	74	CHUB27	CHTAER25ZC	OKU0650004	NEW

- Chiave inclusa
- Key included
- Schluessel inbegriffen

NAKAMURA-TOME

MOD: Super Mill WT150/WT15011/WY250/SC200L - SUPER NTY3 JUMBO

MODULO MOTORIZZATO ASSIALE MOLTIPLICATO I=1:2

Axial geared-up I=1:2 driven tool

Axial angetriebenes Werkzeug uebersetzt I=1:2

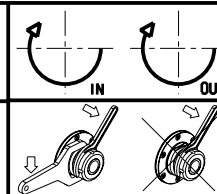

M.T. srl

Via Casino Albini 480
Tel. 0541/956034-957884
Fax 0541/956341

47842 S. GIOVANNI IN M. (RN)
e-mail: mtma@mtmarchetti.com
http://www.mtmarchetti.com

PRODUZIONE MODULI ROTANTI



PAGINA NKM200-4-10

ATTENZIONE - ATTENTION - ACHTUNG

- Per lo smontaggio degli utensili utilizzare sempre la chiave di contrasto come indicato nel manuale d'uso.
- For disassembly of the tools use always the contrast key as mentioned in the user instructions.
- Fuer das Abmontieren der Werkzeuge immer den Gegenschlüssel benutzen wie in der Bedienungsanleitung erwäehnt.

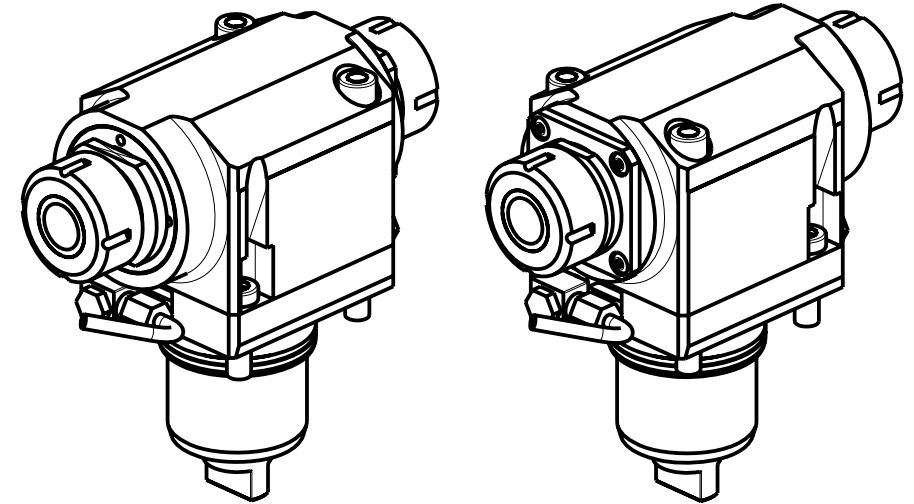
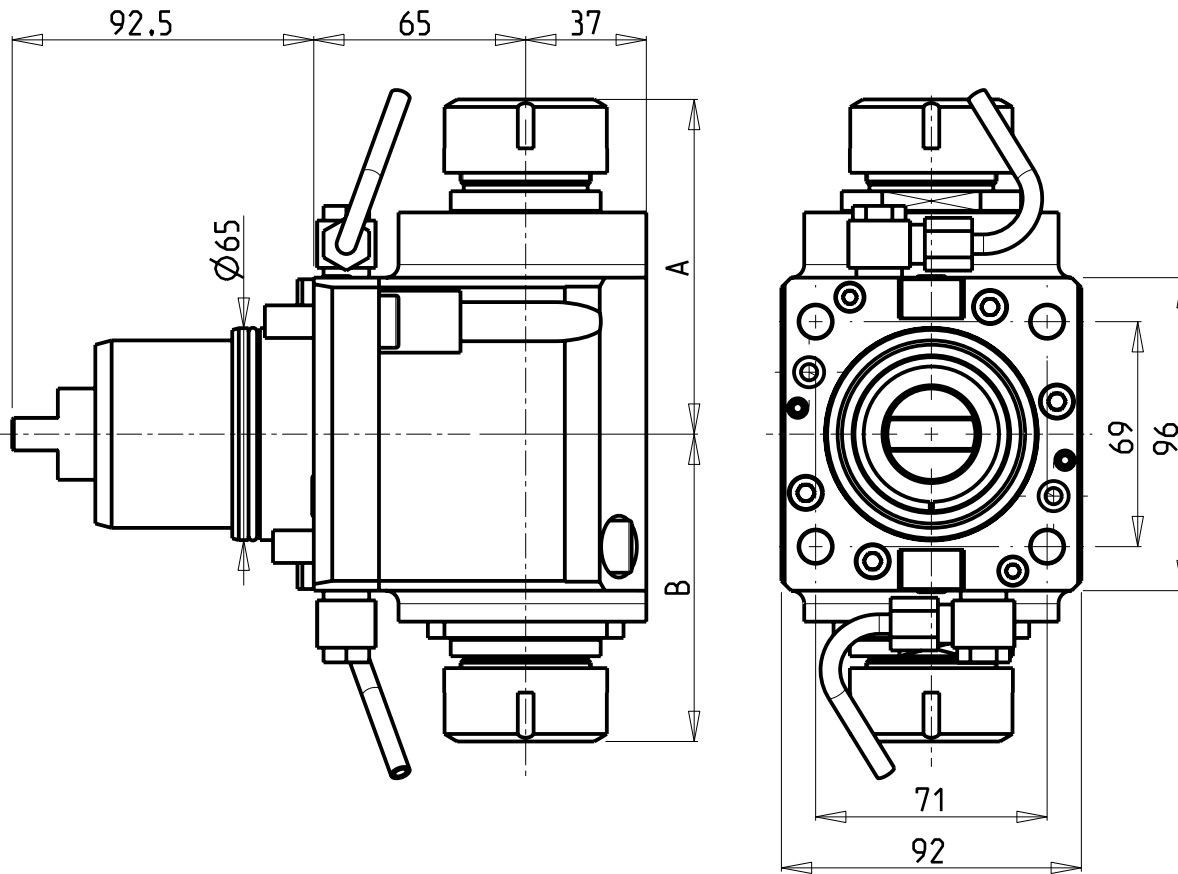

Cod. MT	Mandrino Spindle Spindel	I	RPM	Coppia Max Max Torque Max Drehmoment	Reversibile lato mandrino/contromandrino Reversible sub/main spindle side Umkehrbare Spindel-seite/ Gegenspindel-seite	Lubrificazione est. Ext. coolant Aussenkuehlung	A	B	CHIAVI NON INCLUSE Keys not included Schluessel nicht einbegriffen	
NKM0600232	ER32+ER32	1:1	6000	70Nm	X	X	102.66	94.26	CHSTER32	CHUB46

NAKAMURA-TOME

MOD: Super Mill WT150/WT15011/WY250/SC200L - SUPER NTY3 JUMBO

MODULO MOTORIZZATO ASSIALE BISPORGENTE H=65mm

Axial opposite face twin driven tool H=65mm

Axial angetriebenes Werkzeug halb vorspringend H=65mm

M.T. srl

Via Casino Albini 480
Tel. 0541/956034-957884
Fax 0541/956341
47842 S. GIOVANNI IN M. (RN)
e-mail: mtma@mtmarchetti.com
http://www.mtmarchetti.com

PRODUZIONE MODULI ROTANTI



PAGINA NKM240-4-10

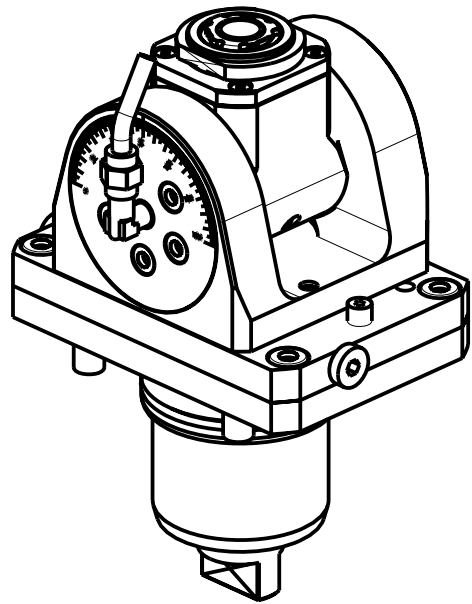
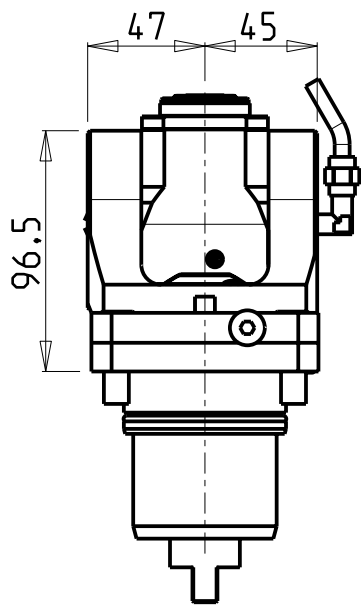
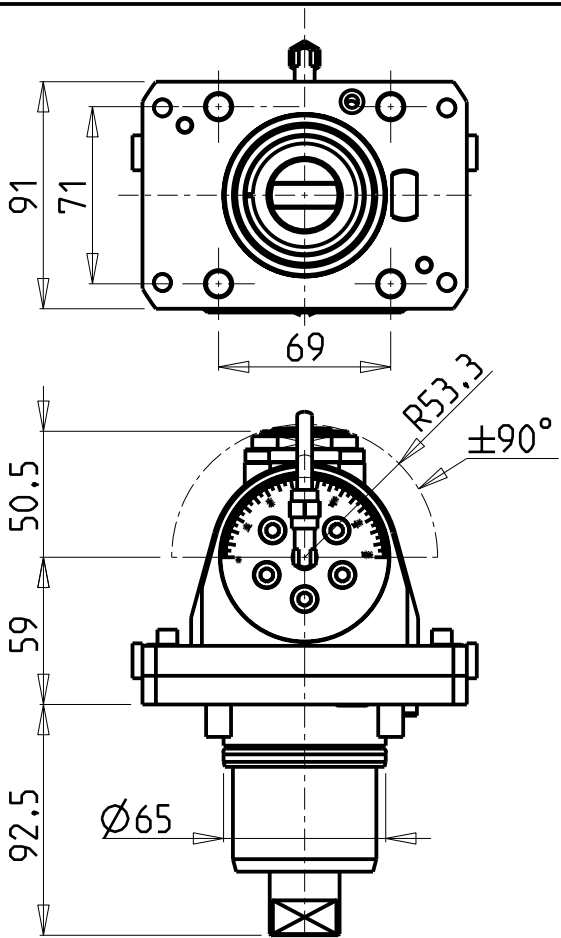

ATTENZIONE - ATTENTION - ACHTUNG

- Per lo smontaggio degli utensili utilizzare sempre la chiave di contrasto come indicato nel manuale d'uso.
- For disassembly of the tools use always the contrast key as mentioned in the user instructions.
- Fuer das Abmontieren der Werkzeuge immer den Gegenschlüssel benutzen wie in der Bedienungsanleitung erwäehnt.

ATTENZIONE - ATTENTION - ACHTUNG

- Verificare la tabella sottostante per possibile interferenza su alcuni modelli di macchine
- Please check the table below for possible interferences on some machine models
- Die untenstehende tabelle unbedingt auf eventuelle interferenzen auf einigen maschinen modellen überprüfen

Cod. MT	Mandrino Spindle Spindel	i	RPM	Coppia Max Max Torque Max Drehmoment	Reversibile lato mandrino/contromandrino Reversible sub/main spindle side Umkehrbare Spindel-seite/ Gegenspindel-seite	Lubr.interna Coolant through Innenkuehlung	Lubrificazione est. Ext. coolant Aussenkuehlung	CHIAVI INCLUSE Keys included Schluessel inbegriffen					
								CHUB22	CHUB36	CHESL05	CHESL07	CHTAER20ZC	
NKM0810120	ERA20	1:1	6000	30Nm	X		X	CHUB22	CHUB36	CHESL05	CHESL07	CHTAER20ZC	NEW
NKM0810220	ERA20	1:1	6000	30Nm	X	P=70bar	X	CHUB22	CHUB36	CHESL05	CHESL07	CHTAER20ZC	NEW

NAKAMURA-TOME

MOD: Super Mill WT150/W T15011/W Y250/SC200L - SUPER NTY3 JUMBO

MODULO MOTORIZZATO ORIENTABILE ±90°
 ±90° adjustable angle driven tool
 Angetriebenes Werkzeug schwenkbar ±90°

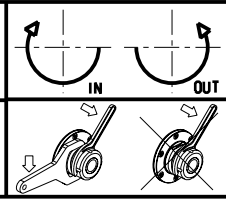

M.T. srl
 Via Casino Albini 480
 Tel. 0541/956034-957884
 Fax 0541/956341
 47842 S. GIOVANNI IN M. (RN)
 e-mail: mtma@mtmarchetti.com
 http://www.mtmarchetti.com

PRODUZIONE MODULI ROTANTI



PAGINA NKM335-4-00

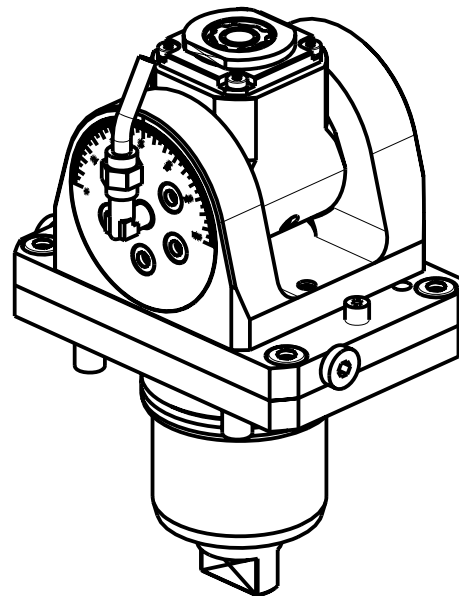
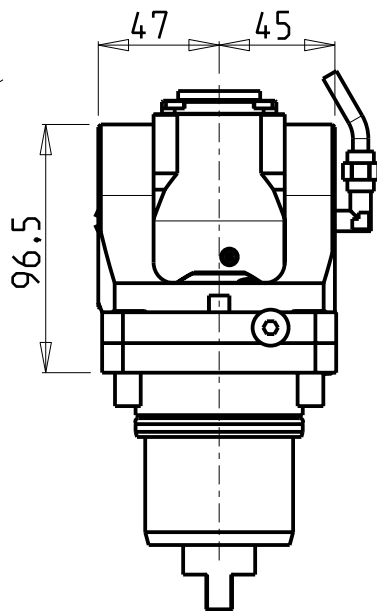
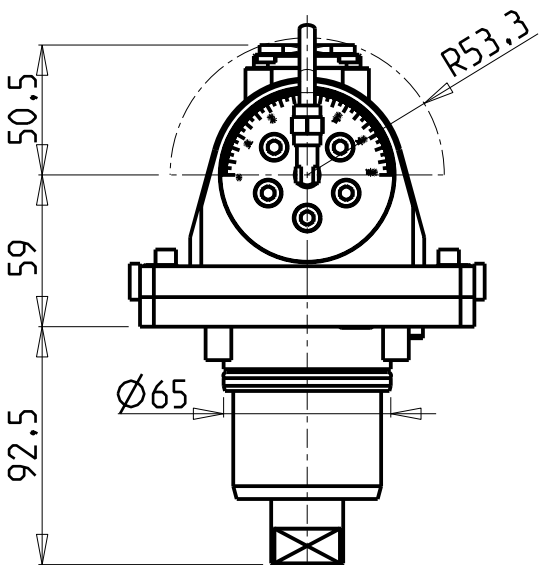
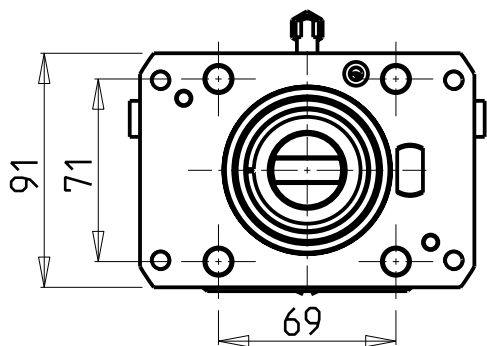

ATTENZIONE - ATTENTION - ACHTUNG

- Per lo smontaggio degli utensili utilizzare sempre la chiave di contrasto come indicato nel manuale d'uso.
- For disassembly of the tools use always the contrast key as mentioned in the user instructions.
- Fuer das Abmontieren der Werkzeuge immer den Gegenschlüssel benutzen wie in der Bedienungsanleitung erwäehnt.

ATTENZIONE - ATTENTION - ACHTUNG

- Verificare la tabella sottostante per possibile interferenza su alcuni modelli di macchine
- Please check the table below for possible interferences on some machine models
- Die untenstehende tabelle unbedingt auf eventuelle interferenzen auf eingen maschinen modellen überprüfen

Cod. MT	Mandrino Spindle Spindel	I	RPM	Coppia Max Max Torque Max Drehmoment	Reversibile lato mandrino/contromandrino Reversible sub/main spindle side Umkehrbare Spindel-seite/ Gegenspindel-seite	Lubr.interna Coolant through Innenkuehlung	Lubrificazione est. Ext. coolant Aussenkuehlung	CHIAVI INCLUSE Keys included Schlüssel inbegriffen					
NKM0810316	ERA16	1:2	12000	8Nm	X		X	CHUB19_SP3	CHUB32	CHESL05	CHESL07	CHTAER16ZC	NEW
NKM0810416	ERA16	1:2	12000	8Nm	X	P=70bar	X	CHUB19_SP3	CHUB32	CHESL05	CHESL07	CHTAER16ZC	NEW

NAKAMURA-TOME

MOD: Super Mill WT150/WT15011/WY250/SC200L - SUPER NTY3 JUMBO

MODULO MOTORIZZATO ORIENTABILE +/-90° MOLTIPLICATO I=1:2

+/-90° adjustable angle driven tool geared-up I=1:2

Angetriebenes Werkzeug schwenkbar +/-90° uebersetzt I=1:2

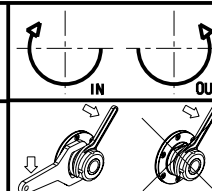

M.T. srl

Via Casino Albini 480
Tel. 0541/956034-957884
Fax 0541/956341

47842 S. GIOVANNI IN M. (RN)
e-mail: mtma@mtmarchetti.com
http://www.mtmarchetti.com

PRODUZIONE MODULI ROTANTI



PAGINA NKM336-4-00

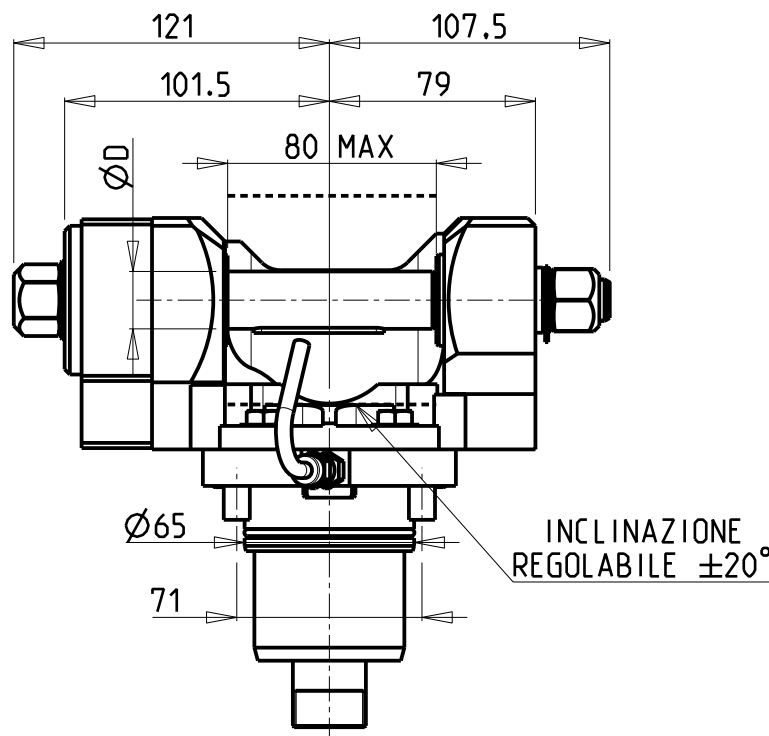
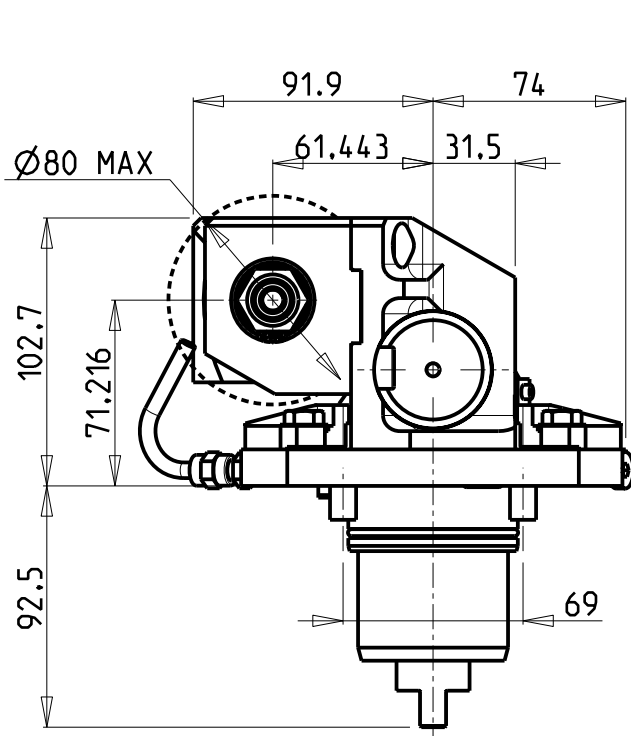

ATTENZIONE - ATTENTION - ACHTUNG

- FUORI VOLTEGGIO!
- OUT OF MAXIMUM SWING!
- WERKZEUG AUSSER INTERFERENZ!

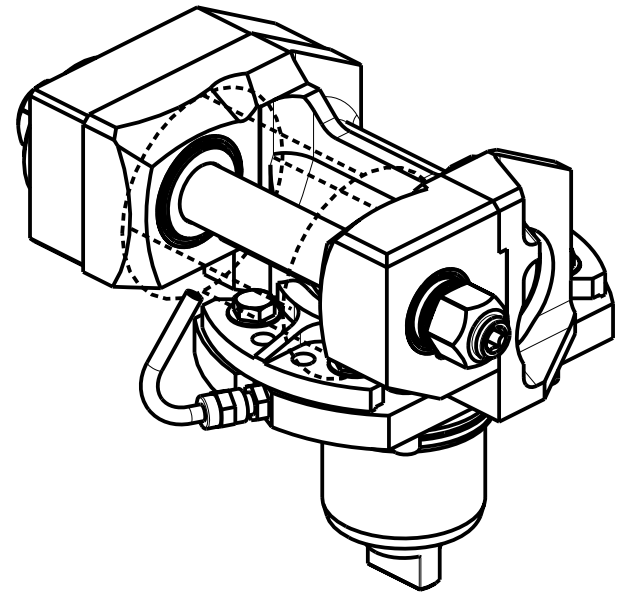

DOTAZIONI - SUPPLIED WITH - AUSSTATTUNG

mm / inch	- N°1 ALBERO + DISTANZIALI - N°1 SHAFT + SPACER - N°1 DORN + ABSTANDSSTUECK
-----------	---

PER ALBERI E DISTANZIALI VEDI PAG. TBL250-1-00
FOR SHAFT END SPACER SEE PAGE TBL250-1-00
FUER DORN UND ABSTANDSSTUECK SEITE TBL250-1-00

Cod. MT	I	RPM max	Coppia Max Max Torque Max Drehmoment	Reversibile lato mandrino/contromandrino Reversible sub/main spindle side Umkehrbare Spindel-seite/ Gegenspindel-seite	Lubrificazione est. Ext. coolant Aussenkuehlung	D (mm)	D (Inch)	CHIAVI INCLUSE Keys included Schluesssel inbegriffen			
								CHUB13	CHUB24	CHESL08	CHESL07
NKM0331100	1:1	6000	60Nm	X	X	16-22-27-32	3/4"-1"-1 1/4"	CHUB13	CHUB24	CHESL08	CHESL07
NKM0332100	2:1	3000	80Nm	X	X	16-22-27-32	3/4"-1"-1 1/4"	CHUB13	CHUB24	CHESL08	CHESL07

NAKAMURA-TOME

MOD: Super Mill WT150/W T15011/W Y250/SC200L - SUPER NTY3 JUMBO

MODULO MOTORIZZATO PORTACREATORE

Driven gear hobber
Angetriebenes Zahnradwaelzfraes-Werkzeug

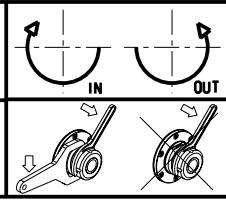

M.T. srl
Via Casino Albini 480
Tel. 0541/956034-957884
Fax 0541/956341
47842 S. GIOVANNI IN M. (RN)
e-mail: mtma@mtmarchetti.com
http://www.mtmarchetti.com

PRODUZIONE MODULI ROTANTI



PAGINA NKM340-4-00

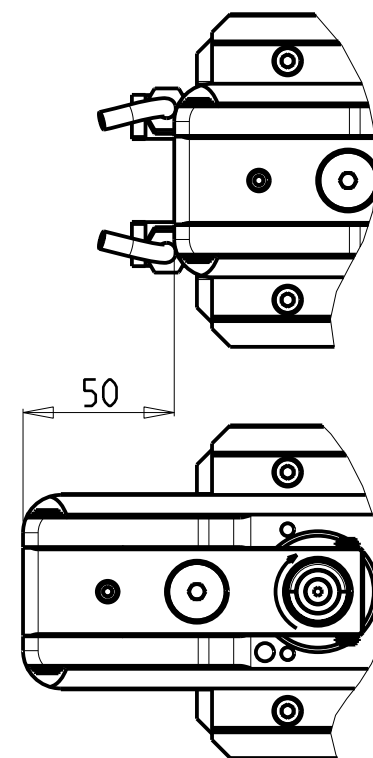
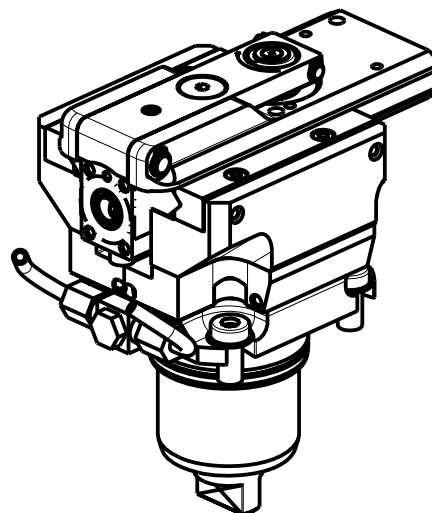
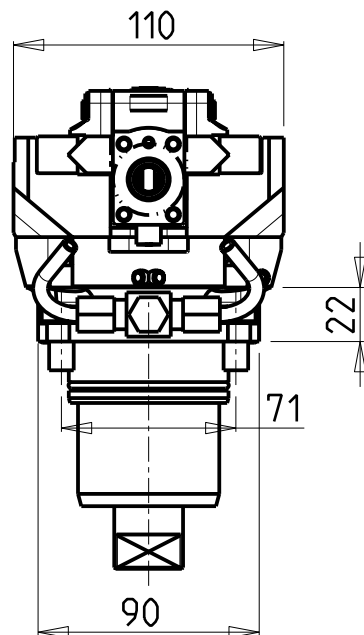
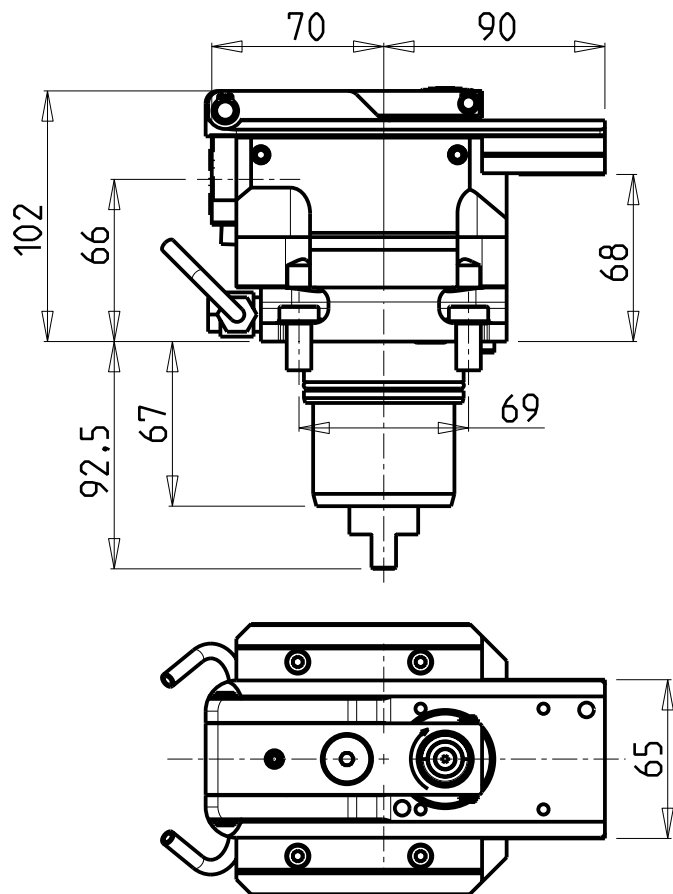

Cod. MT	I	RPM MAX	Reversibile lato mandrino/contromandrino Reversible sub/main spindle side Umkehrbare Spindel-seite/ Gegenspindel-seite	Lubr. esterna Ext. coolant Aussenkuehlung
NKM0940100	4:1	2000	X	X

NEW

PER UTENSILI STOZZATORI VEDI PAG. TBL400-1-00
 FOR DRIVEN SLOTTING TOOL CUTTING-TOOLS SEE PAGE TBL400-1-00
 FÜR NUTENSTOSS-WERKZEUG SCHNEIDWERKZEUGE SIEHE SEITE TBL400-1-00

NAKAMURA-TOME

MOD: Super Mill WT150/WT15011/WY250/SC200L - SUPER NTY3 JUMBO

MODULO MOTORIZZATO STOZZATORE

Slotting driven tool

Keilnutenstossmaschine

M.T. srl

Via Casino Albini 480
 Tel. 0541/956034-957884
 Fax 0541/956341
 47842 S. GIOVANNI IN M. (RN)
 e-mail: mtma@mtmarchetti.com
 http://www.mtmarchetti.com

PRODUZIONE MODULI ROTANTI



PAGINA NKM360-4-00

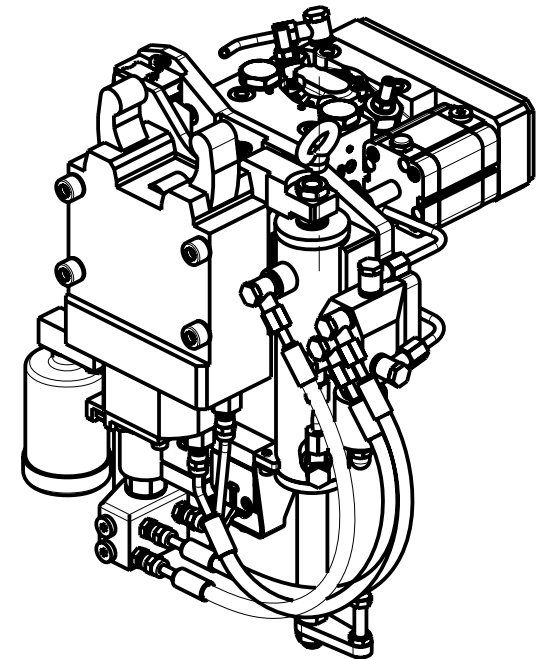
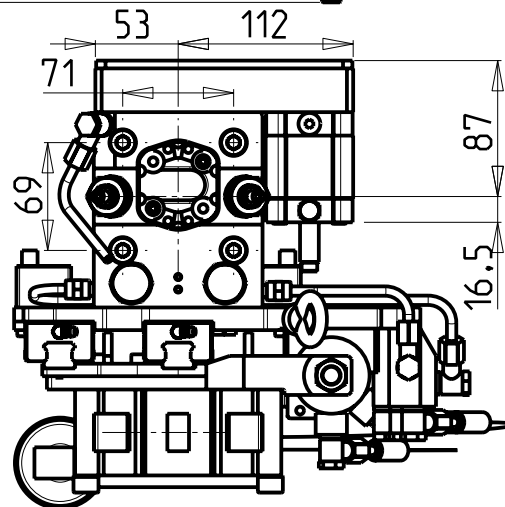
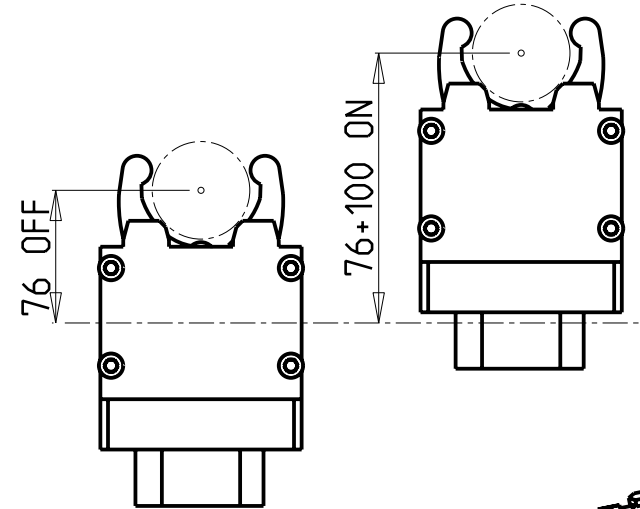
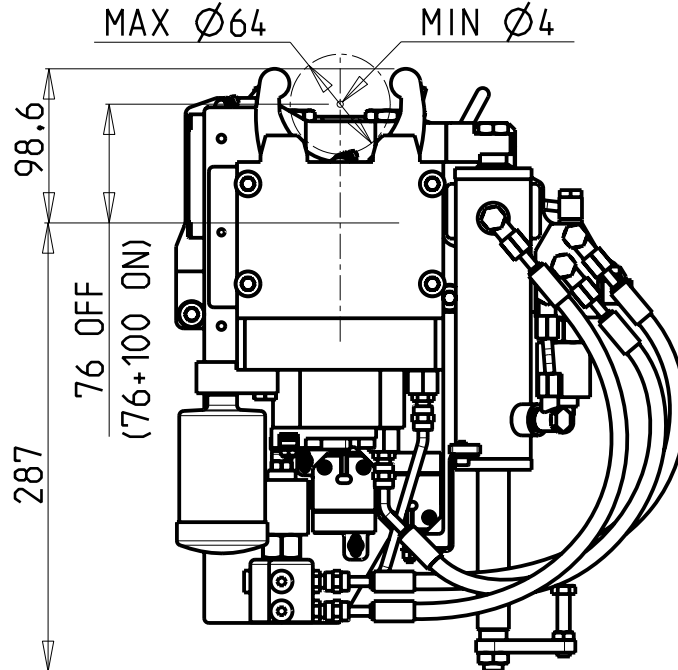
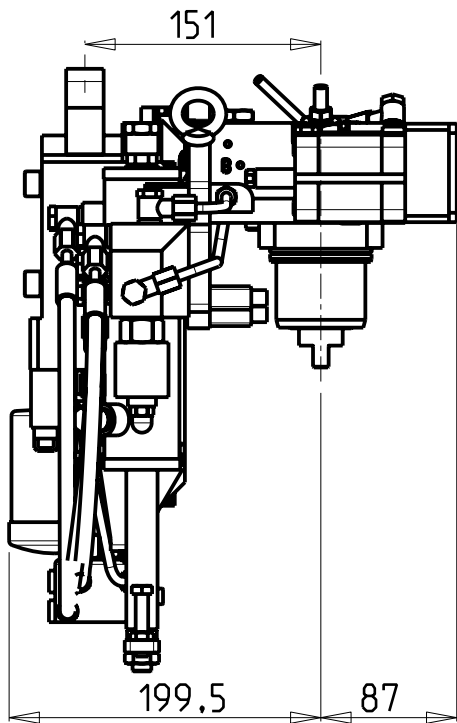

-  # CON GESTIONE ELETTRONICA APERTURA COMPLETA DELLA LUNETTA
 # With Electronic control of steady rest arms complete opening
 # Mit vollständiger elektronischer Öffnungsbedienung der Luenette

Cod. MT	I	RPM	Lubr.esterna Ext. coolant Aussenkuehlung	
NKM0820300	1:1	6000	X	NEW
# NKM0820300A	1:1	6000	X	NEW

NAKAMURA-TOME

MOD: Super Mill WT150/W T150II/WY250 - SUPER NTY3 JUMBO

MODULO MOTORIZZATO PER LUNETTA RETRATTILE (TAGLIA 1)

Driven toolholder for sliding steady rest (Size 1)

Luenettenwerkzeug zurueck versetzte Version (Groesse 1)

M.T. srl

Via Casino Albini 480
 Tel. 0541/956034-957884
 Fax 0541/956341
 47842 S. GIOVANNI IN M. (RN)
 e-mail: mtma@mtmarchetti.com
 http://www.mtmarchetti.com

PRODUZIONE MODULI ROTANTI



PAGINA NKM363-4-00

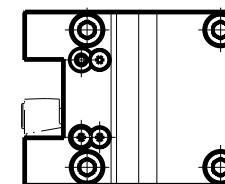
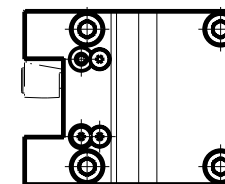
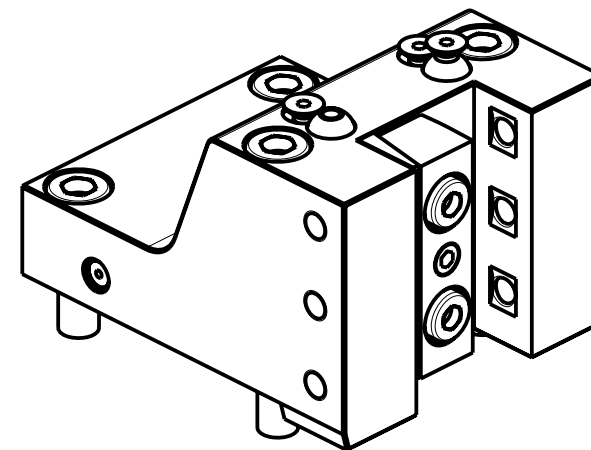
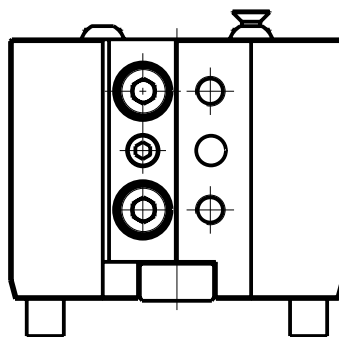
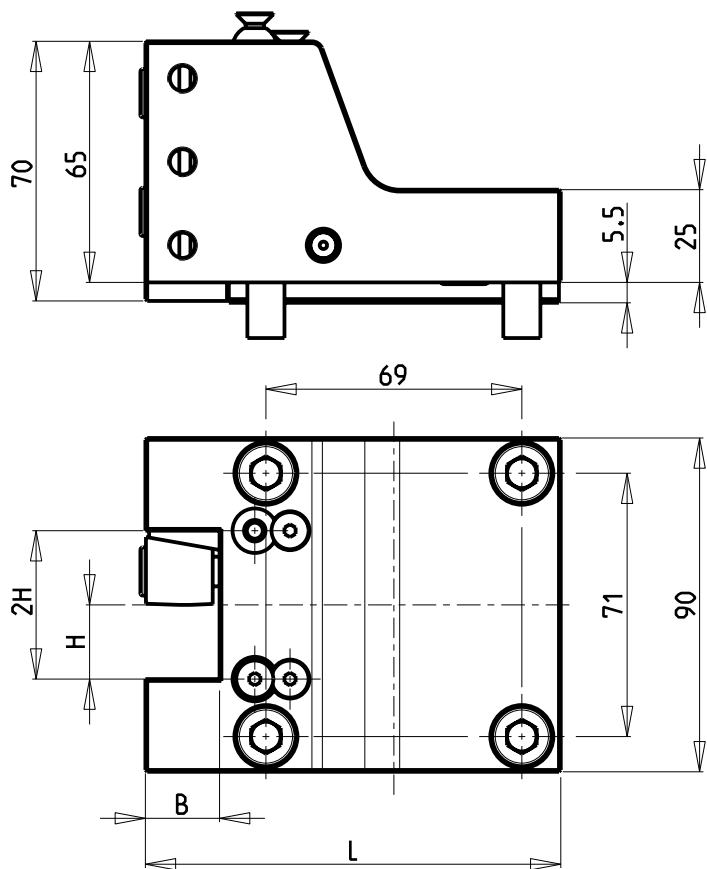

Cod. MT	Cod. NAKAMURA	N°Utensili N°Tools N°Werkzeuge	Reversibile lato mandrino/contromandrino Reversible sub/main spindle side Umkehrbare Spindelseite/ Gegenspindelseite	L	B	H
NKM0412000	G31510/G31520	1/2	X	112	20	20
NKM0412500	G31410/G31420	1/2	X	117	25	25

NAKAMURA-TOME

MOD: Super Mill WT150/WT15011/WY250/SC200L - SUPER NTY3 JUMBO

PORTAUTENSILE RADIALE SINGOLO

Radial single static tool

Radial Single-Werkzeughalter

M.T. srl

Via Casino Albini 480
Tel. 0541/956034-957884
Fax 0541/956341
47842 S. GIOVANNI IN M. (RN)
e-mail: mtma@mtmarchetti.com
http://www.mtmarchetti.com

PRODUZIONE MODULI ROTANTI



PAGINA NKM423-4-00

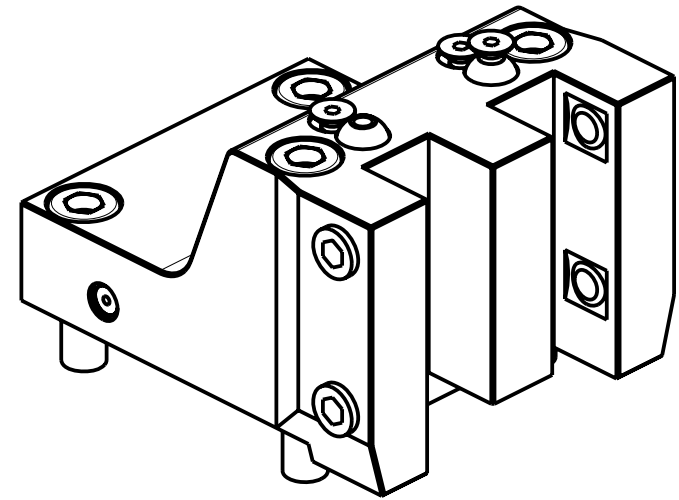
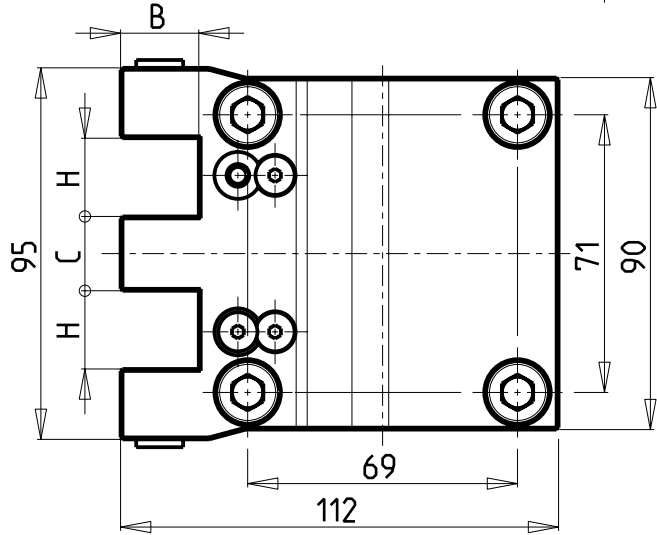
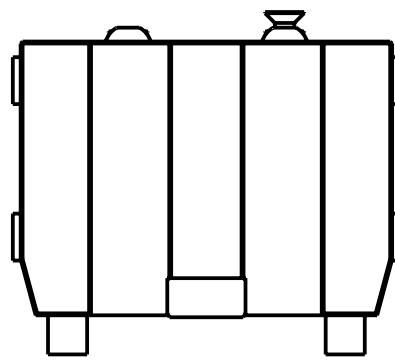
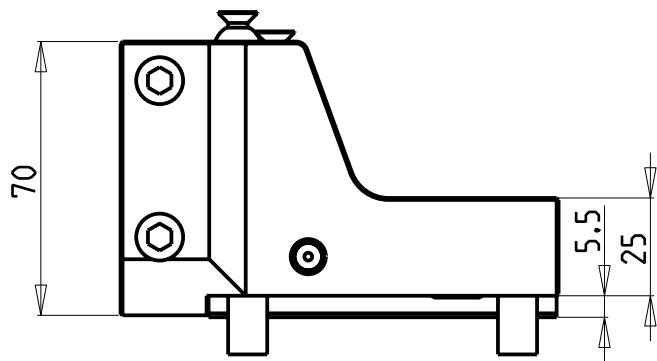

Cod. MT	N°Utensili N°Tools N°Werkzeuge	Reversibile lato mandrino/contromandrino Reversible sub/main spindle side Umkehrbare Spindelseite/ Gegenspindelseite	Misure Dimensions Masse	B	H	C
NKM0362000	2	X	mm	20	20	19
NKM0361905	2	X	inch	3/4"	3/4"	19 (mm)

NAKAMURA-TOME

MOD: Super Mill WT150/WT15011/WY250/SC200L - SUPER NTY3 JUMBO

PORTAUTENSILE RADIALE SOVRAPPOSTO

Radial single side twin static tool

Radial Werkzeughalter ueberlagert

M.T. srl

Via Casino Albini 480
Tel. 0541/956034-957884
Fax 0541/956341
47842 S. GIOVANNI IN M. (RN)
e-mail: mtma@mtmarchetti.com
http://www.mtmarchetti.com

PRODUZIONE MODULI ROTANTI



PAGINA NKM440-4-00

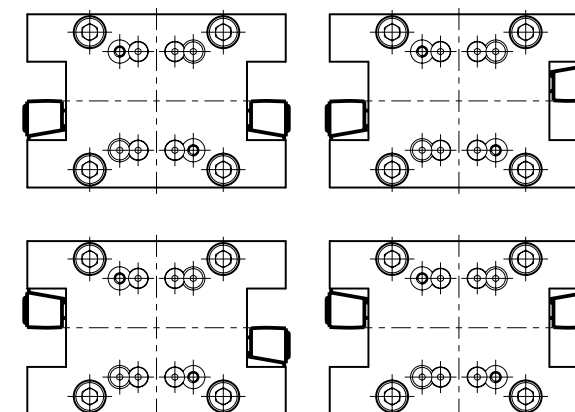
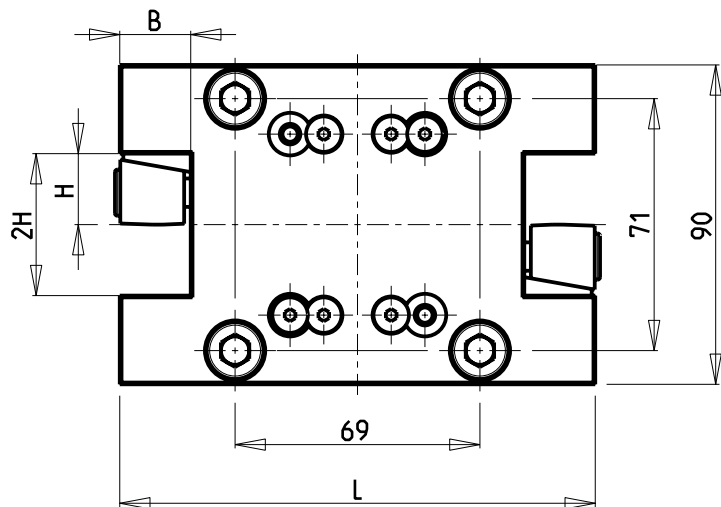
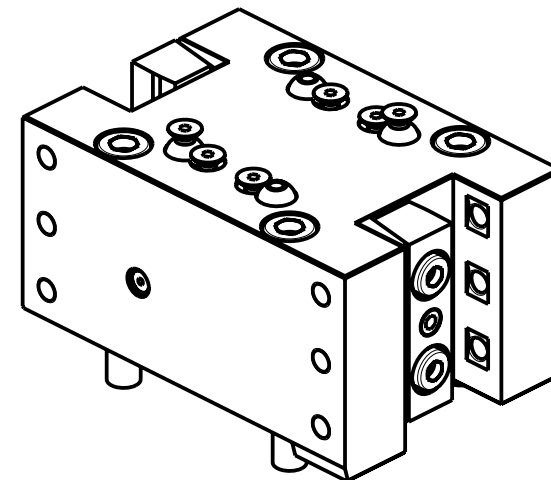
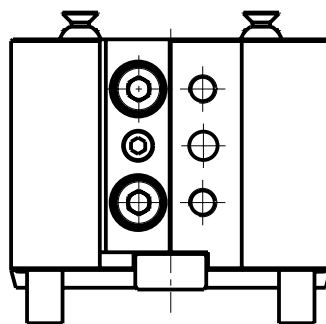
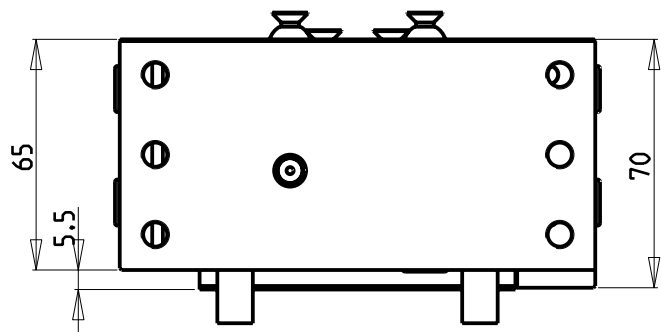

Cod. MT	N°Utensili N°Tools N°Werkzeuge	Reversibile lato mandrino/contromandrino Reversible sub/main spindle side Umkehrbare Spindel-seite/ Gegenspindel-seite	L	B	H
NKM0422000	2	X	134	20	20
NKM0422500	2	X	144	25	25

NAKAMURA-TOME

MOD: Super Mill WT150/WT15011/WY250/SC200L - SUPER NTY3 JUMBO

PORTAUTENSILE RADIALE DOPPIO

Radial double static tool

Radial Doppel-Werkzeughalter

M.T. srl

Via Casino Albini 480
Tel. 0541/956034-957884
Fax 0541/956341
47842 S. GIOVANNI IN M. (RN)
e-mail: mtma@mtmarchetti.com
http://www.mtmarchetti.com

PRODUZIONE MODULI ROTANTI



PAGINA NKM453-4-00

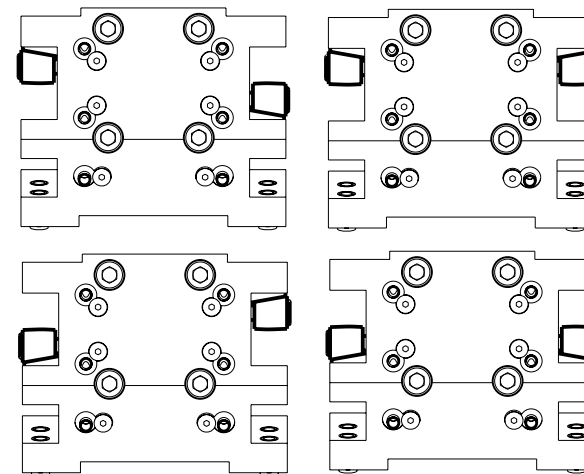
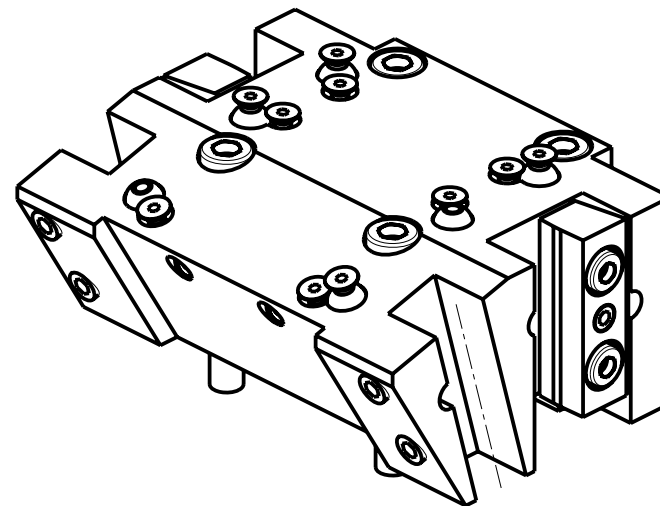
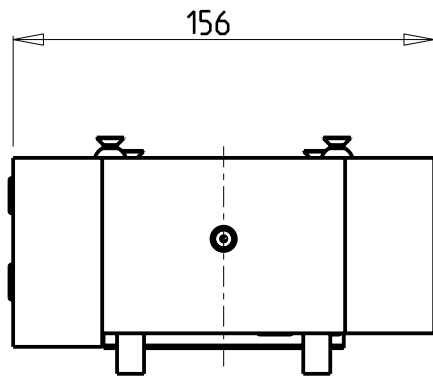
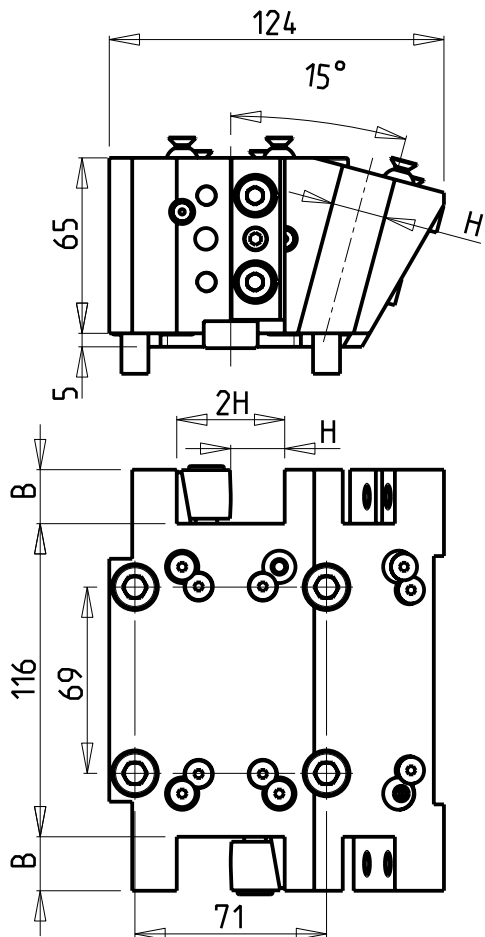

Cod. MT	Cod. NAKAMURA	N°Utensili N°Tools N°Werkzeuge	Reversibile lato mandrino/contromandrino Reversible sub/main spindle side Umkehrbare Spindel-seite/ Gegenspindel-seite	Misure Dimensions Masse	B	H
NKM0382000	G314.16	4	X	mm	20	20
NKM0381905	G314.17	4	X	inch	3/4"	3/4"

NAKAMURA-TOME

MOD: Super Mill WT150/WT15011/WY250/SC200L - SUPER NTY3 JUMBO

PORTAUTENSILE RADIALE MULTIPLO

Radial multiple static tool

Radial Mehrfach-Halter

M.T. srl

Via Casino Albini 480
Tel. 0541/956034-957884
Fax 0541/956341
47842 S. GIOVANNI IN M. (RN)
e-mail: mtma@mtmarchetti.com
<http://www.mtmarchetti.com>

PRODUZIONE MODULI ROTANTI



PAGINA NKM470-4-00

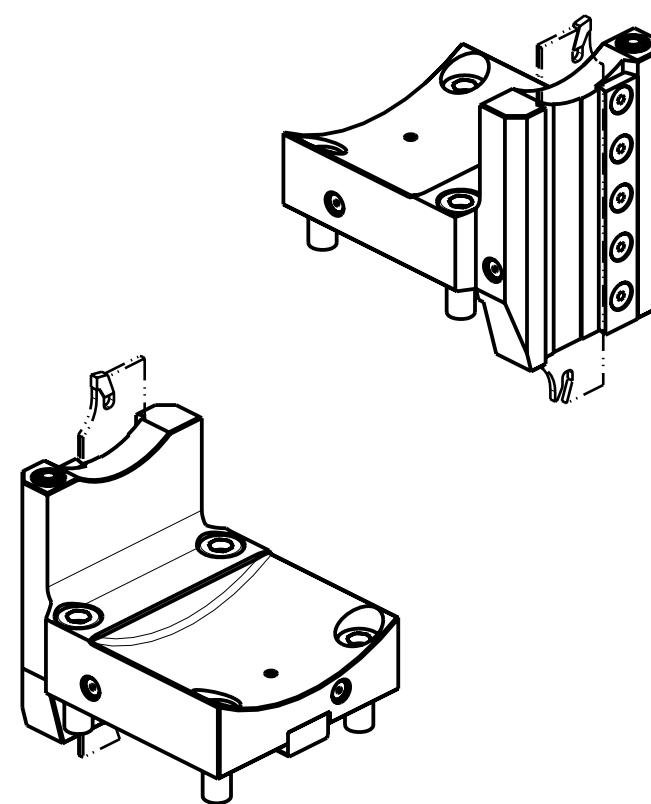
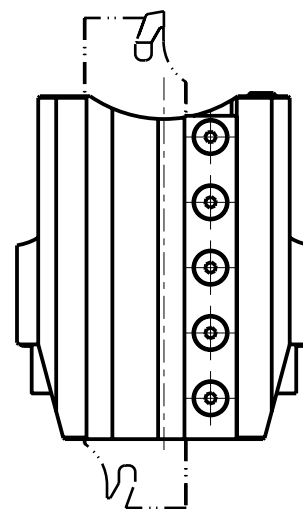
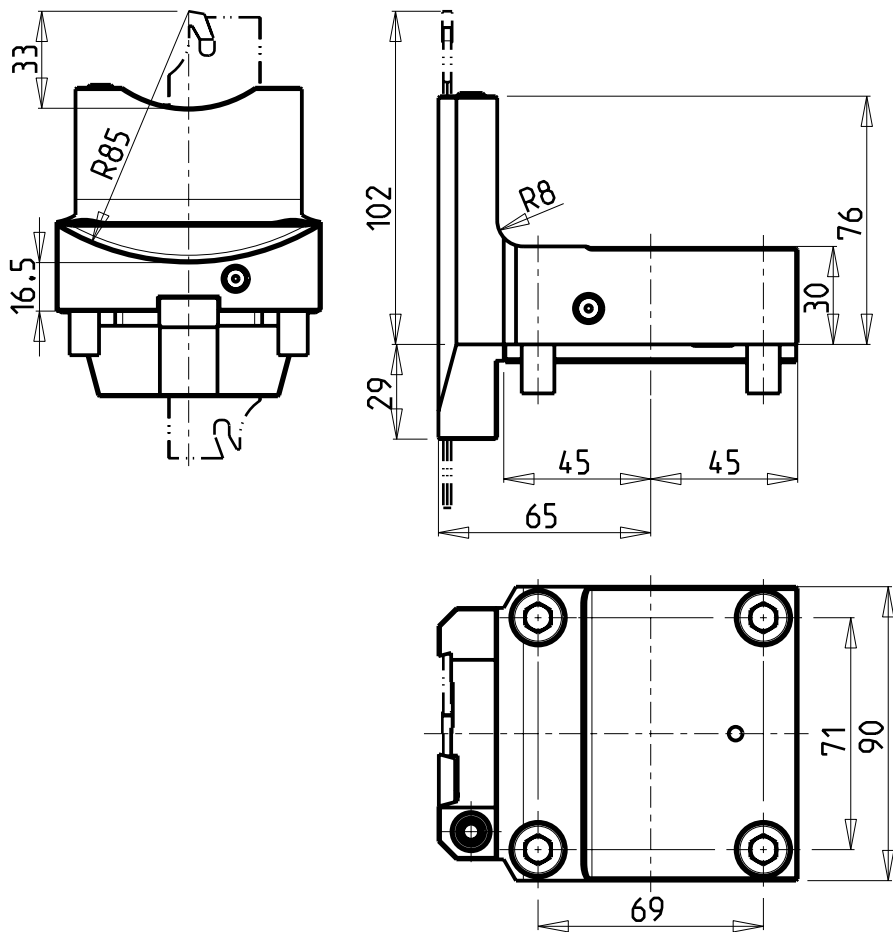

DOTAZIONI - SUPPLIED WITH - AUSSTATTUNG

N°1 - LAMA - BLADE - KLINGE ISCAR H=32 Sp. 3/4mm
(KENNAMETAL OPTIONAL)

N°10 - INSERTI - INSERTS - EINLAGEN

N°1 - CHIAVE A T PER MONTAGGIO INSERTI
- T-WRENCH FOR INSERT SET UP
- T-SCHLUESSEL FUER EINSATZSTUECK-MONTAGE

Cod. MT	N°Utensili N°Tools N°Werkzeuge	Reversibile lato mandrino/contromandrino Reversible sub/main spindle side Umkehrbare Spindel-seite/ Gegenspindel-seite
NKM0400132	1	X

NAKAMURA-TOME

MOD: Super Mill WT150/WT15011/WY250/SC200L - SUPER NTY3 JUMBO

PORTAUTENSILE RADIALE PER LAMA

Radial blade holder

Radial Abstechhalter

M.T. srl

Via Casino Albini 480
Tel. 0541/956034-957884
Fax 0541/956341
47842 S. GIOVANNI IN M. (RN)
e-mail: mtma@mtmarchetti.com
http://www.mtmarchetti.com

PRODUZIONE MODULI ROTANTI



PAGINA NKM510-4-00

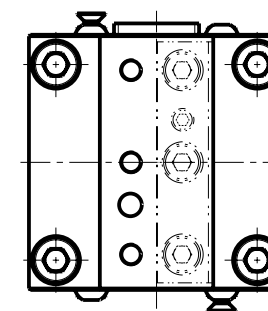
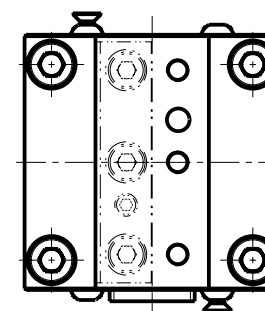
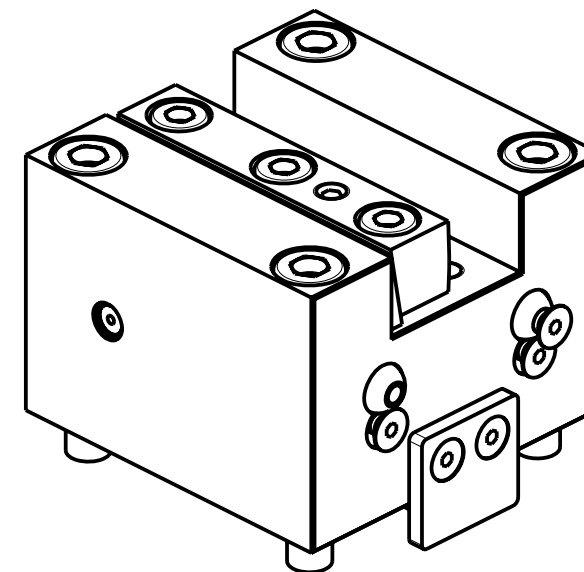
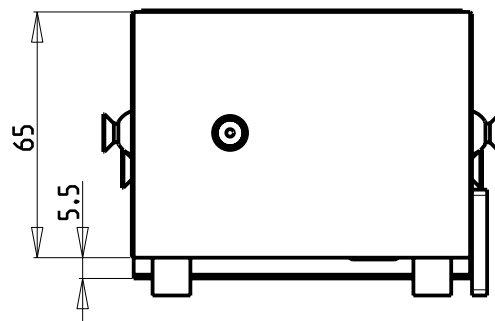
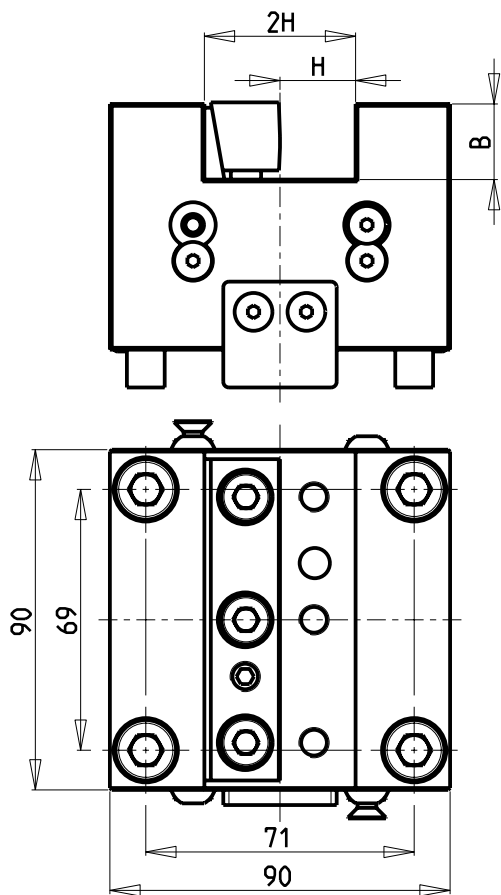

Cod. MT	Cod. NAKAMURA	N°Utensili N°Tools N°Werkzeuge	Reversibile lato mandrino/contromandrino Reversible sub/main spindle side Umkehrbare Spindel-seite/ Gegenspindel-seite	Misure Dimensions Masse	B	H
NKM0432000	G31514	1	X	mm	20	20
NKM0432500	G31414	1	X	mm	25	25

NAKAMURA-TOME

MOD: Super Mill WT150/WT15011/WY250/SC200L - SUPER NTY3 JUMBO

PORTAUTENSILE ASSIALE SINGOLO

Axial single static tool

Axial Single-Werkzeughalter

M.T. srl

Via Casino Albini 480
Tel. 0541/956034-957884
Fax 0541/956341
47842 S. GIOVANNI IN M. (RN)
e-mail: mtma@mtmarchetti.com
http://www.mtmarchetti.com

PRODUZIONE MODULI ROTANTI



PAGINA NKM552-4-00

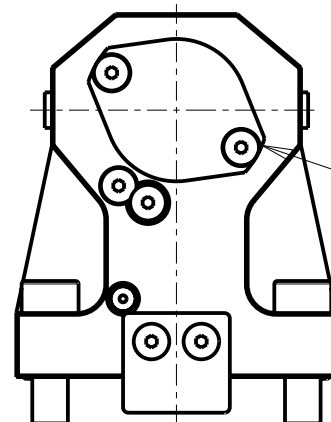
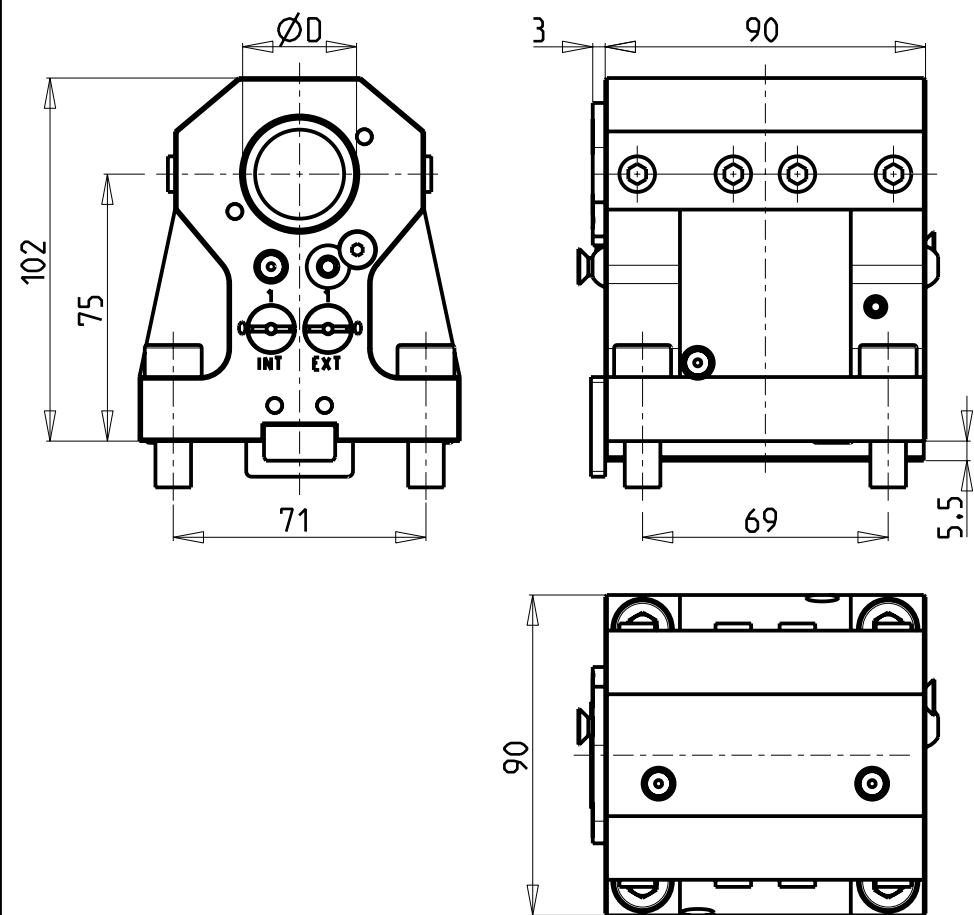

KIT ADDUZIONE INTERNA (OPZIONALE)
 KIT FOR INTERNAL COOLANT (OPTIONAL)
 KIT FUER INTERNE KUEHLMITTELZUFUHR (OPTIONAL)
 Ø32-Ø1 1/4" cod. KIT1000001
 Ø40 cod. KIT1000018

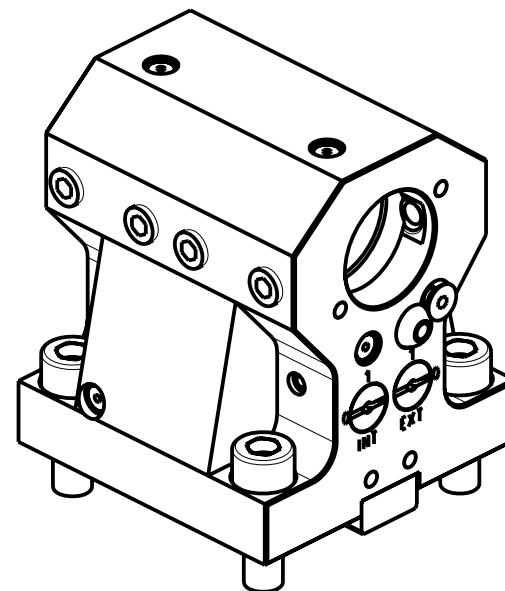

Cod. MT	N°Utensili N°Tools N°Werkzeuge	Reversibile lato mandrino/contromandrino Reversible sub/main spindle side Umkehrbare Spindel-seite/ Gegenspindel-seite	Lubrificazione int. opzionale Coolant through optional Innenkuehlung Optional	Lubrificazione est. Ext. coolant Aussenkuehlung	D
NKM0303200	1	X	X	X	32
NKM0304000	1	X	X	X	40

PER BOCCOLE DI RIDUZIONE VEDI PAG. TBL150-1-00
 FOR REDUCING BUSHINGS SEE PAGE TBL150-1-00
 FÜR REDUZIERBUCHSE SIEHE SEITE TBL150-1-00

NAKAMURA-TOME

MOD: Super Mill WT150/WT15011/WY250/SC200L - SUPER NTY3 JUMBO

PORTAUTENSILE ASSIALE PER BARENO Ø32mm / Ø40mm H=75mm

Axial single boring bar holder Ø32mm / Ø40mm H=75mm

Axial Bohrhälter Ø32mm / Ø40mm H=75mm

M.T. srl

Via Casino Albini 480
 Tel. 0541/956034-957884
 Fax 0541/956341
 47842 S. GIOVANNI IN M. (RN)
 e-mail: mtma@mtmarchetti.com
 http://www.mtmarchetti.com

PRODUZIONE MODULI ROTANTI



PAGINA NKM650-4-10

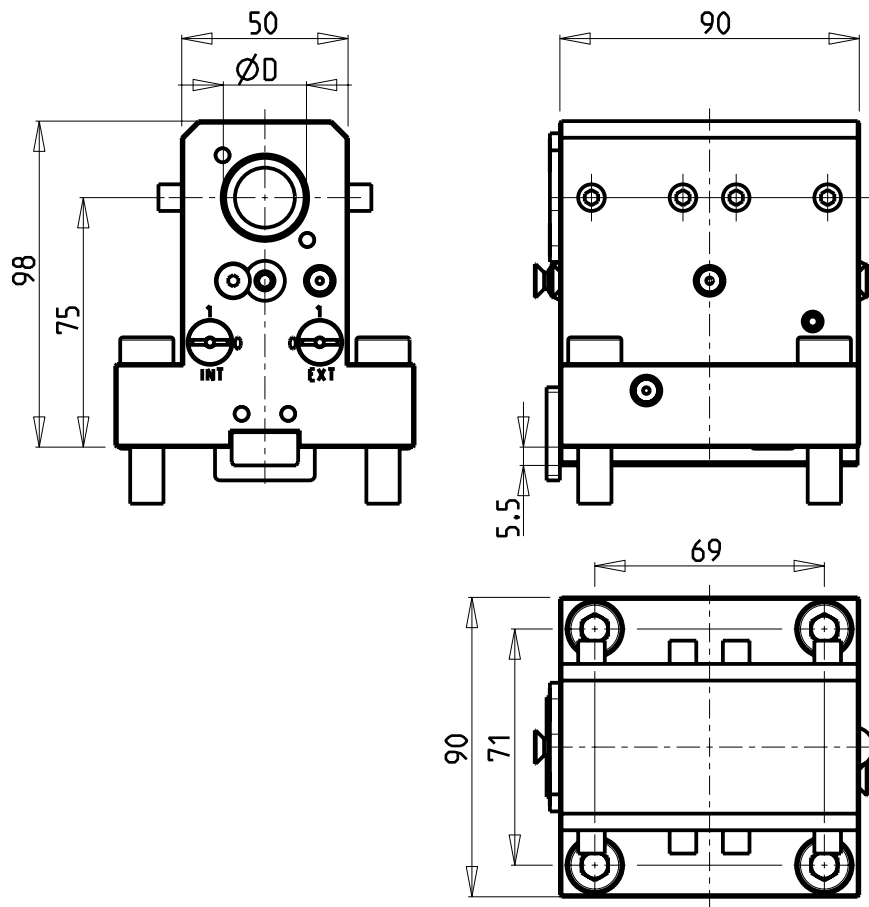

KIT ADDUZIONE INTERNA (OPZIONALE)
 KIT FOR INTERNAL COOLANT (OPTIONAL)
 KIT FUER INTERNE KUEHLMITTELZUFUHR (OPTIONAL)
 Ø25-Ø1" cod. KIT1000006

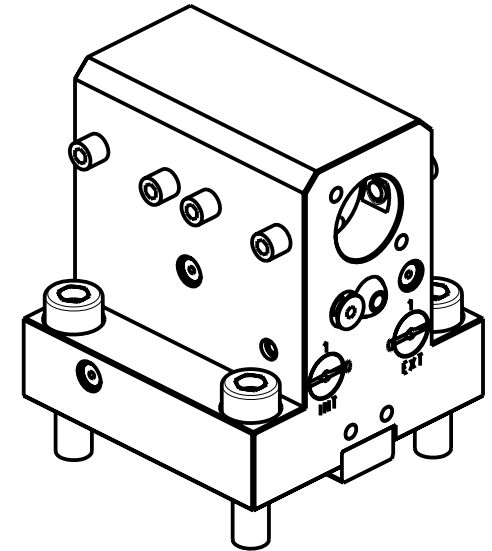
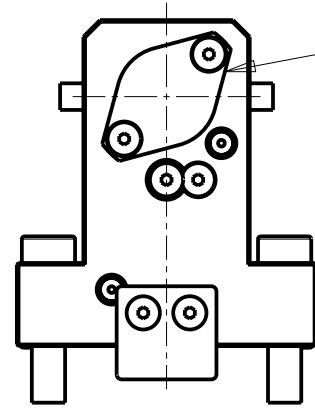

PER BOCCOLE DI RIDUZIONE VEDI PAG. TBL150-1-00
 FOR REDUCING BUSHINGS SEE PAGE TBL150-1-00
 FÜR REDUZIERBUCHSE SIEHE SEITE TBL150-1-00

Cod. MT	N°Utensili N°Tools N°Werkzeuge	Reversibile lato mandrino/contromandrino Reversible sub/main spindle side Umkehrbare Spindel-seite/ Gegenspindel-seite	Lubrificazione int. opzionale Coolant through optional Innenkuehlung Optional	Lubrificazione est. Ext. coolant Aussenkuehlung	Misure Dimensions Masse	D
NKM0302500	1	X	X	X	mm	25
NKM0302540	1	X	X	X	inch	1"

NAKAMURA-TOME

MOD: Super Mill WT150/WT15011/WY250/SC200L - SUPER NTY3 JUMBO

PORTAUTENSILE ASSIALE PER BARENO Ø25mm / Ø1" H=75mm

Axial single boring bar holder Ø25mm / Ø1" H=75mm

Axial Bohrhälter Ø25mm / Ø1" H=75mm

M.T. srl

Via Casino Albini 480
 Tel. 0541/956034-957884
 Fax 0541/956341

47842 S. GIOVANNI IN M. (RN)
 e-mail: mtma@mtmarchetti.com
 http://www.mtmarchetti.com

PRODUZIONE MODULI ROTANTI



PAGINA NKM670-4-10

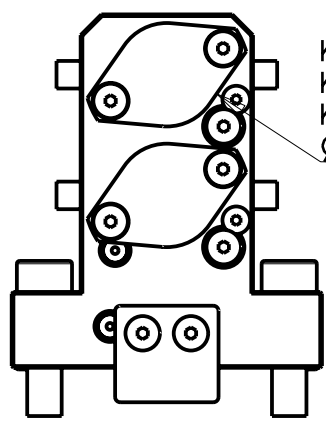
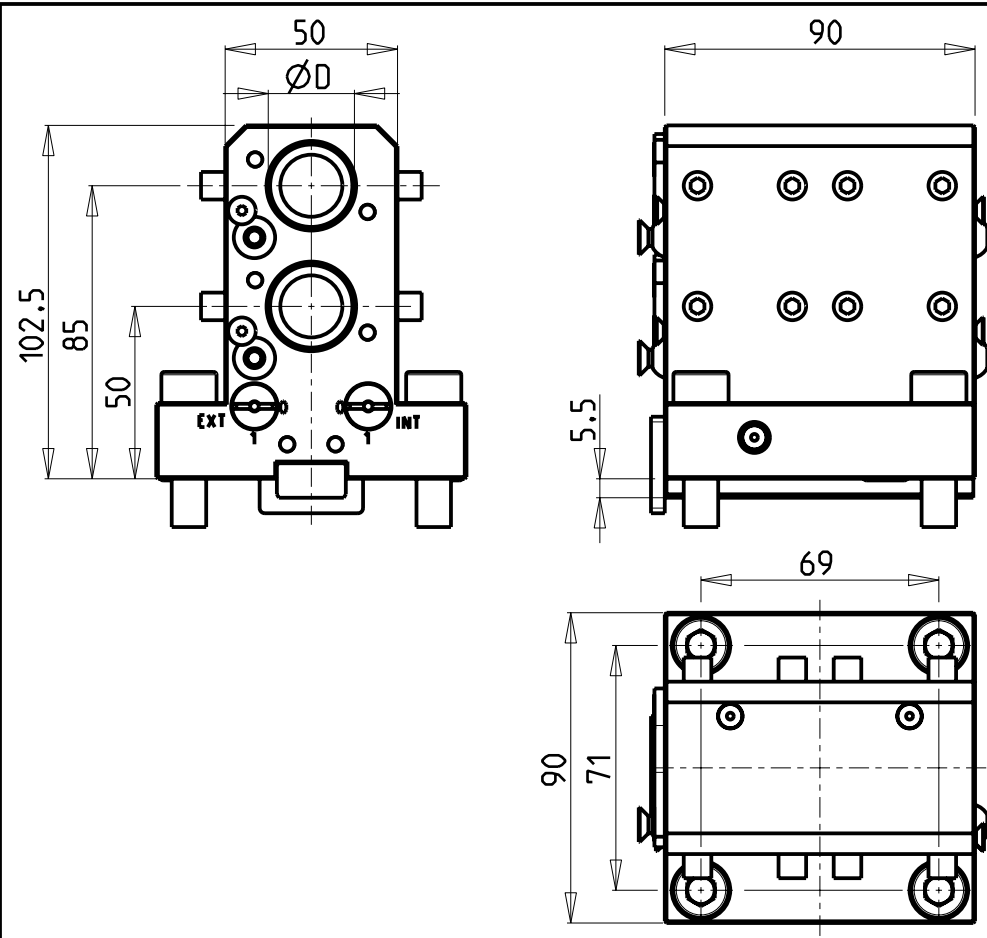

KIT ADDUZIONE INTERNA (OPZIONALE)
 KIT FOR INTERNAL COOLANT (OPTIONAL)
 KIT FUER INTERNE KUEHLMITTELZUFUHR (OPTIONAL)
 Ø25-Ø1" cod. KIT1000006

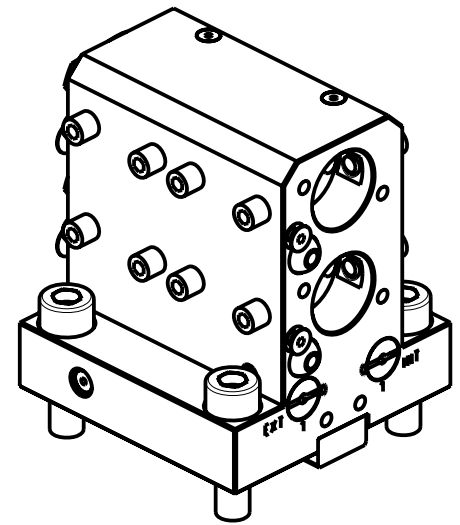

Cod. MT	N°Utensili N°Tools N°Werkzeuge	Reversibile lato mandrino/contromandrino Reversible sub/main spindle side Umkehrbare Spindel-seite/ Gegenspindel-seite	Lubrificazione int. opzionale Coolant through optional Innenkuehlung Optional	Lubrificazione est. Ext. coolant Aussenkuehlung	Misure Dimensions Masse	D
NKM0442500	2	X	X	X	mm	25
NKM0442540	2	X	X	X	inch	1"

PER BOCCOLE DI RIDUZIONE VEDI PAG. TBL150-1-00
 FOR REDUCING BUSHINGS SEE PAGE TBL150-1-00
 FÜR REDUZIERBUCHSE SIEHE SEITE TBL150-1-00

NAKAMURA-TOME
 MOD: Super Mill WT150/WT15011/WY250/SC200L - SUPER NTY3 JUMBO
 PORTAUTENSILE ASSIALE PER BARENO 2 POSIZIONI Ø25mm / Ø1"
 Axial double boring bar holder Ø25mm / Ø1"
 Axial Bohrhalter 2 Positionen Ø25mm / Ø1"



M.T. srl
 Via Casino Albini 480
 Tel. 0541/956034-957884
 Fax 0541/956341
 47842 S. GIOVANNI IN M. (RN)
 e-mail: mtma@mtmarchetti.com
 http://www.mtmarchetti.com

PRODUZIONE MODULI ROTANTI

PAGINA NKM864-4-00

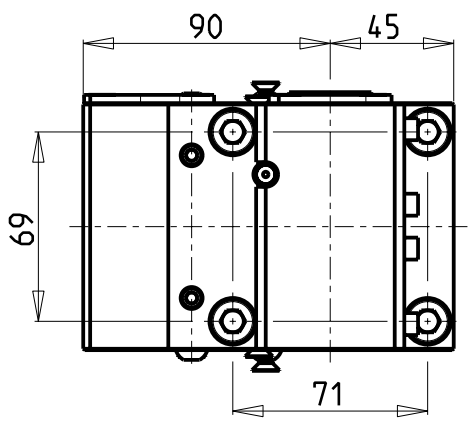
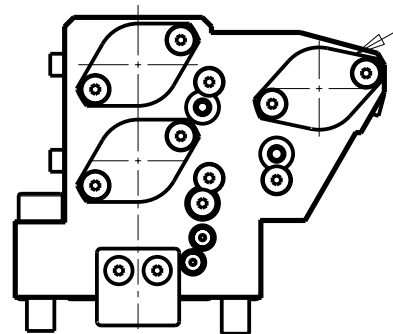
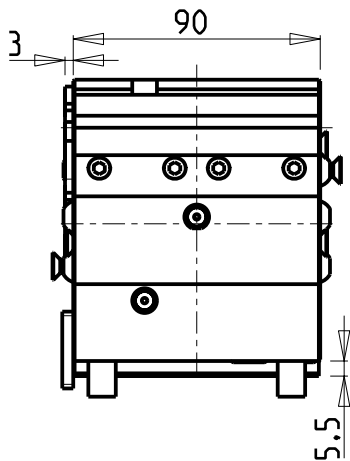
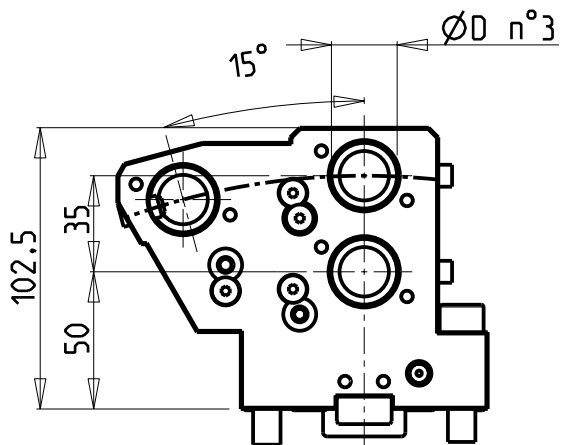

KIT ADDUZIONE INTERNA (OPZIONALE)
 KIT FOR INTERNAL COOLANT (OPTIONAL)
 KIT FUER INTERNE KUEHLMITTELZUFUHR (OPTIONAL)
 Ø25-Ø1" cod. KIT1000006

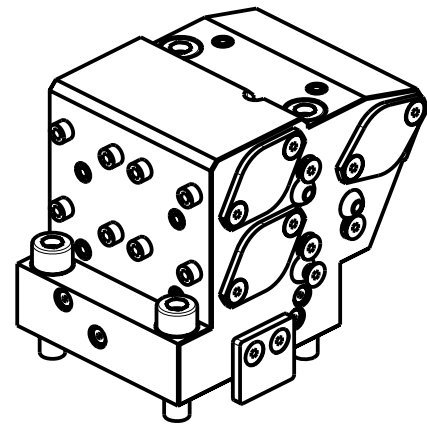

PER BOCCOLE DI RIDUZIONE VEDI PAG. TBL150-1-00
 FOR REDUCING BUSHINGS SEE PAGE TBL150-1-00
 FÜR REDUZIERBUCHSE SIEHE SEITE TBL150-1-00

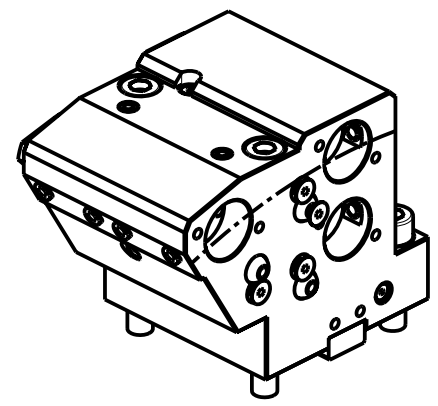

Cod. MT	N°Utensili N°Tools N°Werkzeuge	Reversibile lato mandrino/contromandrino Reversible sub/main spindle side Umkehrbare Spindel-seite/ Gegenspindel-seite	Lubrificazione int. opzionale Coolant through optional Innenkuehlung Optional	Lubrificazione est. Ext. coolant Aussenkuehlung	Misure Dimensions Masse	ØD
NKM0392500	3	X	X	X	mm	25
NKM0392540	3	X	X	X	inch	1"

NAKAMURA-TOME
 MOD: Super Mill WT150/W T15011/WY250/SC200L - SUPER NTY3 JUMBO
 PORTAUTENSILE ASSIALE PER BARENO 3 POSIZIONI Ø25mm / Ø1"
 Axial 3 position boring bar holder Ø25mm / Ø1"
 Axial Bohrhalter 3 Positionen Ø25mm / Ø1"



M.T. srl
 Via Casino Albini 480
 Tel. 0541/956034-957884
 Fax 0541/956341
 47842 S. GIOVANNI IN M. (RN)
 e-mail: mtma@mtmarchetti.com
 http://www.mtmarchetti.com

PRODUZIONE MODULI ROTANTI



PAGINA NKM884-4-00

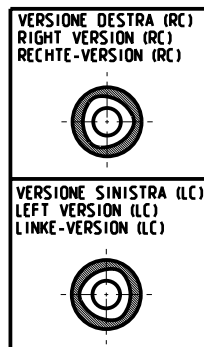
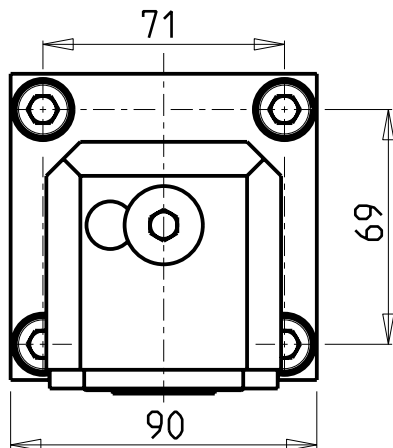
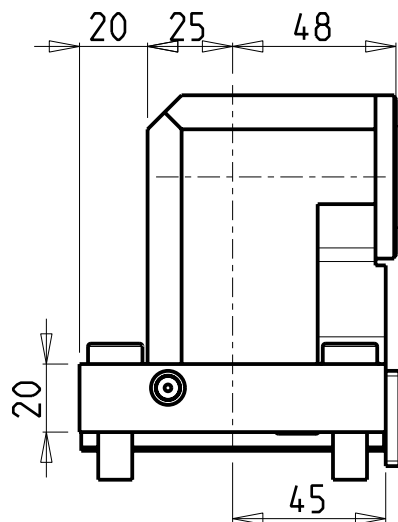
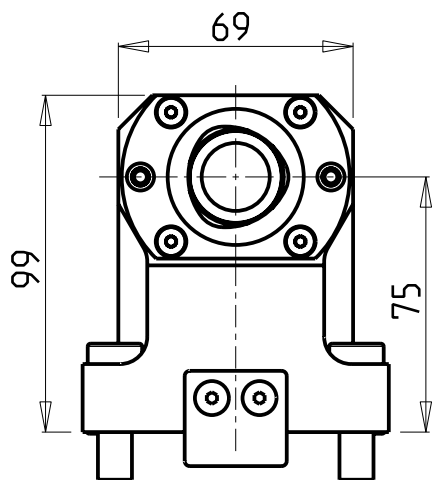

PER ORDINARE LA VERSIONE SX
AGGIUNGERE "LC" AL CODICE IN TABELLA.
ES: MNL0464010 DIVENTA MNL0464010LC

TO ORDER LEFT VERSION
ADD A "LC" IN THE CODE-CHARTS.
EXAMPLE: MNL0464010 BECOMES MNL0464010LC

UM DIE LINKE-VERSION ZU BESTELLEN, BEI DER
ARTIKELBEZEICHNUNG "LC" HINZUFUEGEN.
BEISPIEL: MNL0464010 WIRD DANN MNL0464010LC

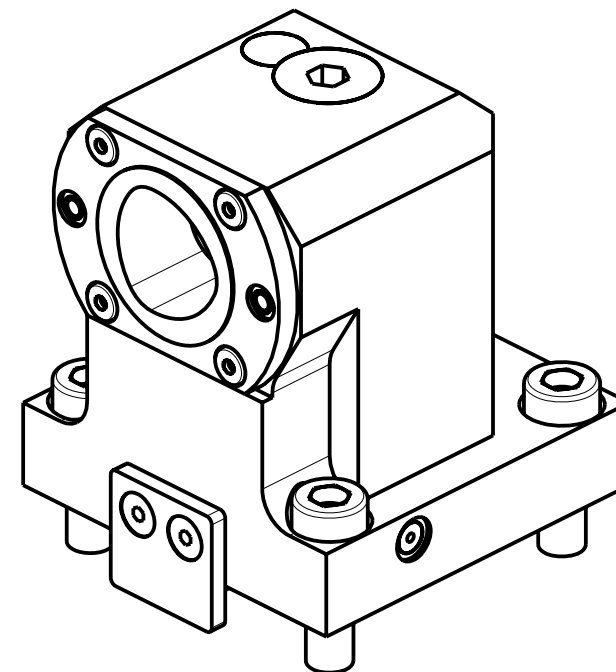

Cod. MT	N°Utensili N°Tools N°Werkzeuge	Lubrificazione int. Coolant through Innenkuehlung	Reversibile lato mandrino/contromandrino Reversible sub/main spindle side Umkehrbare Spindel-seite/ Gegenspindel-seite	TAGLIA Size Masse	
NKM0874010	1	X	X	C4	NEW

NAKAMURA-TOME

MOD: Super Mill WT150/WT15011/WY250/SC200L - SUPER NTY3 JUMBO

PORTAUTENSILE ASSIALE SINGOLO COROMANT CAPTO®

Axial single static tool COROMANT CAPTO®

Axial Single-Werkzeughalter COROMANT CAPTO®

M.T. srl

Via Casino Albini 480
Tel. 0541/956034-957884
Fax 0541/956341

47842 S. GIOVANNI IN M. (RN)
e-mail: mtma@mtmarchetti.com
http://www.mtmarchetti.com

PRODUZIONE MODULI ROTANTI



PAGINA NKM550-D-40