

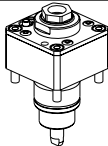





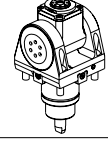
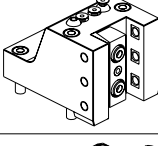
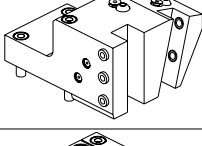
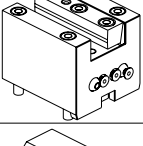
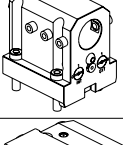
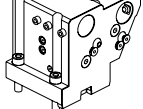
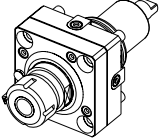
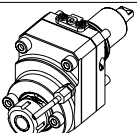
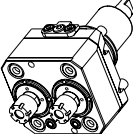
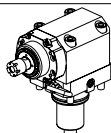
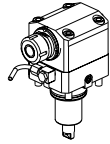
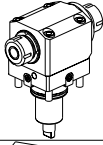
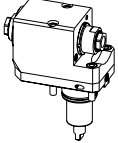
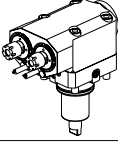
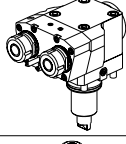

		PAGINA Page Seite
<b>MODULO MOTORIZZATO RADIALE</b> Radial driven tool Radial angetriebenes Werkzeug		DW 0010.1.00
<b>MODULO MOTORIZZATO ASSIALE</b> Axial driven tool Axial angetriebenes Werkzeug		DW 0150.1.00
<b>MODULO MOTORIZZATO ORIENTABILE ±90°</b> ±90° adjustable angle driven tool Angetriebenes Werkzeug schwenkbar ±90°		DW 0335.1.00
<b>PORTAUTENSILE RADIALE SINGOLO</b> Radial single static tool Radial Single-Werkzeughalter		DW 0420.1.00
<b>PORTAUTENSILE RADIALE MULTIPLO</b> Radial multiple static tool Radial Mehrfach-Halter		DW 0440.1.50
<b>PORTAUTENSILE ASSIALE SINGOLO</b> Axial single static tool Axial Single-Werkzeughalter		DW 0550.1.00
<b>PORTAUTENSILE ASSIALE PER BARENO Ø32mm / Ø1 1/4" H=65mm</b> Axial single boring bar holder Ø32mm / Ø1 1/4" H=65mm Axial Bohrhalter Ø32mm / Ø1 1/4" H=65mm		DW 0650.1.10
<b>PORTAUTENSILE ASSIALE PER BARENO 2 POSIZIONI Ø25mm / Ø1"</b> Axial double boring bar holder Ø25mm / Ø1" Axial Bohrhalter 2 Positionen Ø25mm / Ø1"		DW 0864.1.50

		PAGINA Page Seite
<b>MODULO MOTORIZZATO RADIALE</b> Radial driven tool Radial angetriebenes Werkzeug		DW0010.2.00
<b>MODULO MOTORIZZATO RADIALE DISASSATO IN Z 36mm</b> Radial driven tool re-directed in Z by 36mm Radial angetriebenes Werkzeug achsversetzt in Z um 36mm		DW0030.2.10
<b>MODULO MOTORIZZATO RADIALE RIDOTTO I=2:1 DISASSATO IN Z 36mm</b> Radial geared-down I=2:1 driven tool re-directed in Z by 36mm Radial angetriebenes Werkzeug untersetzt I=2:1 achsversetzt in Z um 36mm		DW0030.2.20
<b>MODULO MOTORIZZ. RADIALE MOLTIPLICATO I=1:2 DISASSATO IN Z 36mm</b> Radial geared-up I=1:2 driven tool re-directed in Z by 36mm Radial angetriebenes Werkzeug uebersetzt I=1:2 achsversetzt in Z um 36mm		DW0030.2.30
<b>MODULO MOTORIZ. RADIALE MOLTIPLICATO I=1:5,625</b> Radial geared-up I=1:5.625 driven tool Radial angetriebenes Werkzeug uebersetzt I=1:5.625		DW0060.2.00
<b>MODULO MOTORIZZATO RADIALE 2 USCITE IN Y</b> Radial single side I twin head driven tool in Y Radial angetriebenes Werkzeug 2 Ausgaenge in Y		DW0080.2.00
<b>MODULO MOTORIZZATO ASSIALE H=60mm</b> Axial driven tool H=60mm Axial angetriebenes Werkzeug H=60mm		DW0150.2.10
<b>MODULO MOTORIZZATO ASSIALE H=70mm</b> Axial driven tool H=70mm Axial angetriebenes Werkzeug H=70mm		DW0150.2.20
<b>MODULO MOTORIZZATO ASSIALE H=85mm</b> Axial driven tool H=85mm Axial angetriebenes Werkzeug H=85mm		DW0150.2.30
<b>MODULO MOTORIZZATO ASSIALE ARRETRATO</b> Axial rear-set driven tool Axial angetriebenes Werkzeug zurueckversetzt		DW0180.2.10
<b>MODULO MOTORIZZATO ASSIALE MOLTIPLICATO I=1:2</b> Axial geared-up I=1:2 driven tool Axial angetriebenes Werkzeug uebersetzt I=1:2		DW0200.2.10
<b>MODULO MOTORIZZATO ASSIALE MOLTIPLICATO I=1:5,625</b> Axial geared-up I=1:5.625 driven tool Axial angetriebenes Werkzeug uebersetzt I=1:5.625		DW0210.2.10

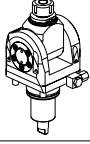
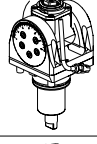
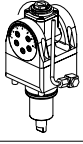
		PAGINA Page Seite
<p><b>MODULO MOTORIZZATO ASSIALE PER POLIGONATURA INTERNA</b> Axial driven tool for internal polygon-making Axial angetriebenes Werkzeug fuer interne Facettierung</p>		DW 0230.2.10
<p><b>MODULO MOTORIZZATO ASSIALE BISPORGENTE</b> Axial opposite face twin driven tool Axial angetriebenes Werkzeug halb vorspringend</p>		DW 0240.2.10
<p><b>MODULO MOTORIZZATO ASSIALE ARRETRATO BISPORGENTE</b> Axial opposite face rear-set driven tool Axial angetriebenes Werkzeug zurueckversetzt halb vorspringend</p>		DW 0243.2.10
<p><b>MODULO MOTORIZZATO ASSIALE 2 USCITE IN Y</b> Axial single side twin head driven tool in Y Axial angetriebenes Werkzeug 2 Ausgaenge in Y</p>		DW 0260.2.10
<p><b>MODULO MOTORIZZATO ASSIALE 2 USCITE IN Y MOLTIPLICATO I=1:2</b> Axial geared-up I=1:2 single side twin head driven tool in Y Axial angetriebenes Werkzeug 2 Ausgaenge in Y uebersetzt I=1:2</p>		DW 0261.2.10 
<p><b>MODULO MOTORIZZATO ORIENTABILE 0-90°</b> 0-90° adjustable angle driven tool Angetriebenes Werkzeug schwenkbar 0-90°</p>		DW 0330.2.00
<p><b>MODULO MOTORIZZATO ORIENTABILE ±90° H=47,5mm</b> ±90° adjustable angle driven tool H=47,5mm Angetriebenes Werkzeug schwenkbar ±90° H=47,5mm</p>		DW 0335.2.00
<p><b>MODULO MOTORIZZATO ORIENTABILE ±90° H=83mm</b> ±90° adjustable angle driven tool H=83mm Angetriebenes Werkzeug schwenkbar ±90° H=83mm</p>		DW 0335.2.10
<p><b>MODULO MOTORIZZATO ORIENTABILE ±90° MOLTIPLICATO I=1:2 H=47,5mm</b> ±90° adjustable angle driven tool geared-up I=1:2 H=47,5mm Angetriebenes Werkzeug schwenkbar ±90° uebersetzt I=1:2 H=47,5mm</p>		DW 0336.2.00
<p><b>MODULO MOTORIZZATO ORIENTABILE ±90° MOLTIPLICATO I=1:2 H=83mm</b> ±90° adjustable angle driven tool geared-up I=1:2 H=83mm Angetriebenes Werkzeug schwenkbar ±90° uebersetzt I=1:2 H=83mm</p>		DW 0336.2.10
<p><b>MODULO MOTORIZZATO PORTACREATORE</b> Driven gear hobber Angetriebenes Zahnradwaelzfraes-Werkzeug</p>		DW 0340.2.00
<p><b>MODULO MOTORIZZATO PORTACREATORE RADIALE</b> Radial driven gear hobber Radial Angetriebenes Zahnradwaelzfraes-Werkzeug</p>		DW 0340.2.30

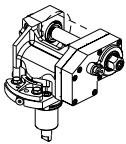
		PAGINA Page Seite
<b>MODULO MOTORIZZATO STOZZATORE</b> Slotting driven tool Keilnutenstossmaschine		DW0360.2.00 <b>NEW</b>
<b>MODULO MOTORIZZATO PER LUNETTA RETRATTILE (TAGLIA 1)</b> Driven toolholder for sliding steady rest (Size 1) Luennettenwerkzeug zurueck versetzte Version (Grossesse 1)		DW0363.2.00 <b>NEW</b>
<b>INTERFACCIA PER MODULI BMT 55 H=45mm</b> BMT55 tooling adapter cartridge H=45mm Adapter Patrone fuer BMT55 Werkzeuge H=45mm		DW0385.2.00
<b>PORTAUTENSILE RADIALE SOVRAPPOSTO</b> Radial single side twin static tool Radial Werkzeughalter ueberlagert		DW0442.2.00
<b>PORTAUTENSILE RADIALE DOPPIO SOVRAPPOSTO</b> Radial double side twin static tool Radial Doppel-Werkzeughalter ueberlagert		DW0463.2.00
<b>PORTAUTENSILE RADIALE PER LAMA</b> Radial blade holder Radial Abstechhalter		DW0510.2.00 <b>NEW</b>
<b>PORTAUTENSILE PER LAMA DOPPIO</b> Radial double blade holder Radial Doppel-Abstechhalter		DW0520.2.00
<b>PORTAUTENSILE ASSIALE SINGOLO</b> Axial single static tool Axial Single-Werkzeughalter		DW0552.2.00
<b>PORTAUTENSILE ASSIALE PER BARENO Ø50mm / Ø2" H=100mm</b> Axial single boring bar holder Ø50mm / Ø2" H=100mm Axial Bohrhalter Ø50mm / Ø2" H=100mm		DW0620.2.10 <b>NEW</b>
<b>PORTAUTENSILE ASSIALE PER BARENO Ø40mm / Ø1 1/2" H=60mm</b> Axial single boring bar holder Ø40mm / Ø1 1/2" H=60mm Axial Bohrhalter Ø40mm / Ø1 1/2" H=60mm		DW0630.2.20
<b>PORTAUTENSILE ASSIALE PER BARENO Ø40mm / Ø1 1/2" H=100mm</b> Axial single boring bar holder Ø40mm / Ø1 1/2" H=100mm Axial Bohrhalter Ø40mm / Ø1 1/2" H=100mm		DW0640.2.10
<b>PORTAUT. ASSIALE PER BARENO 2 POSIZIONI Ø25mm / Ø1" / Ø1 1/4" / Ø32mm</b> Axial double boring bar holder Ø25mm / Ø1" / Ø1 1/4" / Ø32mm Axial Bohrhalter 2 positionen Ø25mm / Ø1" / Ø1 1/4" / Ø32mm		DW0862.2.00

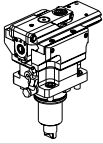
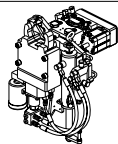
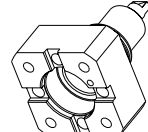
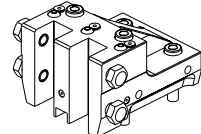
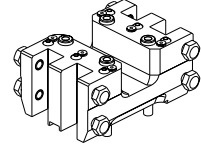
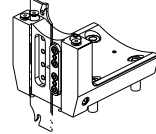
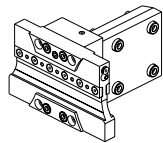
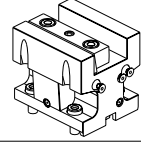
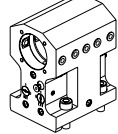
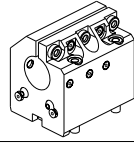
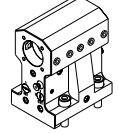
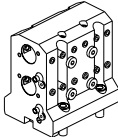
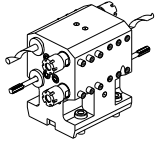
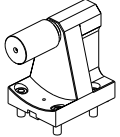
		PAGINA Page Seite
<p><b>PORTAUTENSILE ASSIALE PER BARENO 4+4 POSIZIONI Ø 20mm / Ø 3/4"</b> Axial 4+4 position boring bar holder Ø20mm / Ø3/4" Axial Bohrhalter 4+4 Positionen Ø20mm / Ø3/4"</p>		DW 0924.2.00
<p><b>CONTROPUNTA PER CONTROMANDRINO</b> Tailstock for subspindle Gegenspitz fuer Gegenspindel</p>		DW 0950.2.00

<p><b>PORTAUTENSILE RADIALE SINGOLO ARRETRATO COROMANT CAPTO®</b> Radial single rear-set static tool COROMANT CAPTO® Radial Single-Werkzeughalter zurueckversetzt COROMANT CAPTO®</p>		DW 0430.B.40
---	---	--------------

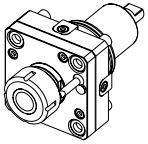
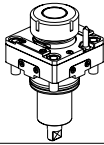
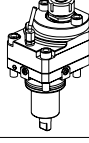
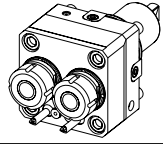
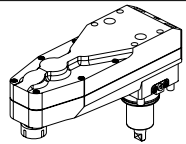
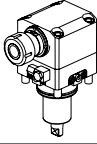
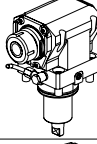
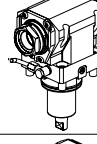
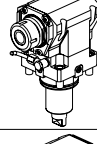
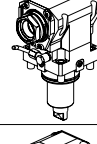
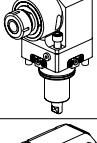
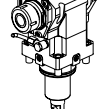
		PAGINA Page Seite
<b>MODULO MOTORIZZATO RADIALE</b> Radial driven tool Radial angetriebenes Werkzeug		DW 0010.3.00
<b>MODULO MOTORIZZATO RADIALE MAGGIORATO</b> Radial reinforced driven tool Radial angetriebenes Werkzeug vergrößert		DW 0020.3.00
<b>MODULO MOTORIZZATO RADIALE MOLTIPLICATO I=1:2 DISASSATO IN Z 36mm</b> Radial geared-up I=1:2 driven tool re-directed in Z by 36mm Radial angetriebenes Werkzeug uebersetzt I=1:2 achsversetzt in Z um 36mm		DW 0030.3.30
<b>MODULO MOTORIZZATO RADIALE 2 USCITE IN Y</b> Radial single side twin head driven tool in Y Radial angetriebenes Werkzeug 2 Ausgaenge in Y		DW 0080.3.00
<b>MODULO MOTORIZZATO RADIALE ROVESCiato DISASSATO IN Z 250mm</b> Radial inverted driven tool re-directed in Z by 250mm Radial angetriebenes Werkzeug umgekehrt achsversetzt in Z um 250mm		DW 0120.3.10
<b>MODULO MOTORIZZATO ASSIALE H=72mm</b> Axial driven tool H=72mm Axial angetriebenes Werkzeug H=72mm		DW 0150.3.10
<b>MODULO MOTORIZZATO ASSIALE H=72mm</b> Axial driven tool H=72mm Axial angetriebenes Werkzeug H=72mm		DW 0150.3.11 <b>NEW</b>
<b>MODULO MOTORIZZATO ASSIALE MTSK H=72mm</b> Axial MTSK driven tool H=72mm Axial MTSK angetriebenes Werkzeug H=72mm		DW 0150.3.11.K <b>NEW</b>
<b>MODULO MOTORIZZATO ASSIALE H=85mm</b> Axial driven tool H=85mm Axial angetriebenes Werkzeug H=85mm		DW 0150.3.15 <b>NEW</b>
<b>MODULO MOTORIZZATO ASSIALE MTSK H=85mm</b> Axial MTSK driven tool H=85mm Axial MTSK angetriebenes Werkzeug H=85mm		DW 0150.3.15.K <b>NEW</b>
<b>MODULO MOTORIZZATO ASSIALE H=100mm</b> Axial driven tool H=100mm Axial angetriebenes Werkzeug H=100mm		DW 0150.3.20
<b>MODULO MOTORIZZATO ASSIALE H=100mm</b> Axial driven tool H=100mm Axial angetriebenes Werkzeug H=100mm		DW 0150.3.21 <b>NEW</b>

		PAGINA Page Seite
<b>MODULO MOTORIZZATO ASSIALE MTSK H=100mm</b> Axial MTSK driven tool H=100mm Axial MTSK angetriebenes Werkzeug H=100mm		DW 0150.3.21.K <b>NEW</b>
<b>MODULO MOTORIZZATO ASSIALE MOLTIPLICATO I=1:2</b> Axial geared-up I=1:2 driven tool Axial angetriebenes Werkzeug uebersetzt I=1:2		DW 0200.3.20 <b>NEW</b>
<b>MODULO MOTORIZZATO ASSIALE BISPORGENTE H=72mm</b> Axial opposite face driven tool H=72mm Axial angetriebenes Werkzeug halb vorspringend H=72mm		DW 0240.3.10 <b>NEW</b>
<b>MODULO MOTORIZZATO ASSIALE BISPORGENTE H=85mm</b> Axial opposite face driven tool H=85mm Axial angetriebenes Werkzeug halb vorspringend H=85mm		DW 0240.3.15 <b>NEW</b>
<b>MODULO MOTORIZZATO ASSIALE BISPORGENTE H=100mm</b> Axial opposite face twin driven tool H=100mm Axial angetriebenes Werkzeug halb vorspringend H=100mm		DW 0240.3.20
<b>MODULO MOTORIZZATO ASSIALE BISPORGENTE H=100mm</b> Axial opposite face driven tool H=100mm Axial angetriebenes Werkzeug halb vorspringend H=100mm		DW 0240.3.21 <b>NEW</b>
<b>MODULO MOTORIZZATO ASSIALE 2 USCITE IN Y</b> Axial single side twin head driven tool in Y Axial angetriebenes Werkzeug 2 Ausgaenge in Y		DW 0260.3.10 <b>NEW</b>
<b>MODULO MOTORIZZATO ORIENTABILE 0-90°</b> 0-90° adjustable angle driven tool Angetriebenes Werkzeug schwenkbar 0-90°		DW 0330.3.00
<b>MODULO MOTORIZZATO PORTACREATORE</b> Driven gear hobber Angetriebenes Zahnradwaelzfraes-Werkzeug		DW 0340.3.00
<b>MODULO MOTORIZZATO PORTACREATORE MAGGIORATO</b> Reinforced driven gear hobber Angetriebenes Zahnradwaelzfraes-Werkzeug vergroessert		DW 0340.3.60
<b>MODULO MOTORIZZATO PER LUNETTA RETRATTILE (TAGLIA 2)</b> Driven toolholder for sliding steady rest (Size 2) Luenettenwerkzeug zurueck versetzte Version (Grossesse 2)		DW 0363.3.00 <b>NEW</b>
<b>PORTAUTENSILE RADIALE SINGOLO</b> Radial single static tool Radial Single-Werkzeughalter		DW 0423.3.00

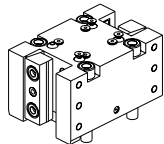
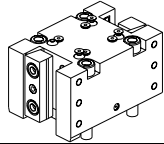
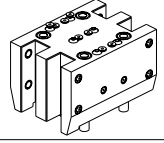
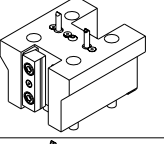
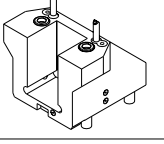
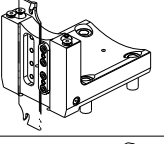
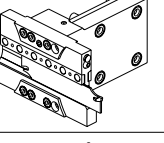
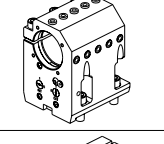
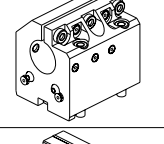
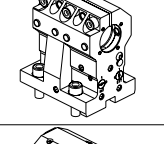
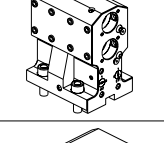
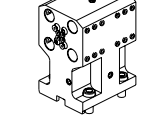
		PAGINA Page Seite
<b>PORTAUTENSILE RADIALE DOPPIO H=90mm</b> Radial double static tool H=90mm Radial Doppel-Werkzeughalter H=90mm		DW0453.3.00
<b>PORTAUTENSILE RADIALE DOPPIO H=75mm</b> Radial double static tool H=75mm Radial Doppel-Werkzeughalter H=75mm		DW0453.3.10
<b>PORTAUTENSILE RADIALE DOPPIO SOVRAPPOSTO</b> Radial double side twin static tool Radial Doppel-Werkzeughalter ueberlagert		DW0463.3.00
<b>PORTAUTENSILE RADIALE DOPPIO CON SEDE ATTACCO COROMANT CAPTO®</b> Radial double static tool with seat for Coromant Capto® connection Radial Doppel-Werkzeughalter mit sitz fuer Coromant Capto® Anschluss		DW0495.3.00
<b>PORTAUTENSILE RADIALE CON SEDE ATTACCO COROMANT CAPTO®</b> Radial tool with seat for Coromant Capto® connection Radial Single-Werkzeughalter mit sitz fuer Coromant Capto® Anschluss		DW0500.3.00
<b>PORTAUTENSILE RADIALE PER LAMA</b> Radial blade holder Radial Abstechhalter		DW0510.3.00 <b>NEW</b>
<b>PORTAUTENSILE PER LAMA DOPPIO</b> Radial double blade holder Radial Doppel-Abstechhalter		DW0520.3.00
<b>PORTAUTENSILE ASSIALE PER BARENO Ø60mm H=100mm</b> Axial single boring bar holder Ø60mm H=100mm Axial Bohrhalter Ø60mm H=100mm		DW0590.3.20 <b>NEW</b>
<b>PORTAUTENSILE ASSIALE PER BARENO Ø40mm/Ø1 1/2"/Ø50mm/Ø2" H=72mm</b> Axial single boring bar holder Ø40mm/Ø1 1/2"/Ø50mm/Ø2" H=72mm Axial Bohrhalter Ø40mm/Ø1 1/2"/Ø50mm/Ø2" H=72mm		DW0610.3.20
<b>PORTAUTENSILE ASSIALE PER BARENO Ø40mm H=100mm</b> Axial single boring bar holder Ø40mm H=100mm Axial Bohrhalter Ø40mm H=100mm		DW0640.3.20
<b>PORTAUTENSILE ASSIALE PER BARENO 2 POSIZIONI Ø32mm</b> Axial double boring bar holder Ø32mm Axial Bohrhalter 2 Positionen Ø32mm		DW0862.3.00
<b>PORTAUTENSILE ASSIALE PER BARENO 4+4 POSIZIONI Ø20mm/Ø3/4"</b> Axial 4+4 position boring bar holder Ø20mm/Ø3/4" Axial Bohrhalter 4+4 Positionen Ø20mm/Ø3/4"		DW0924.3.00



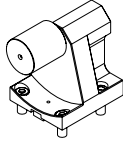

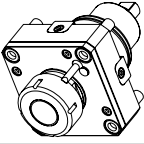
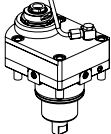
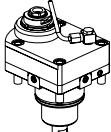
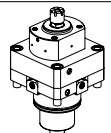
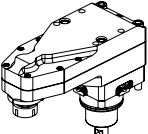
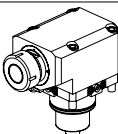
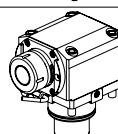
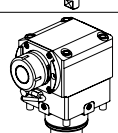
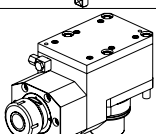
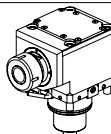
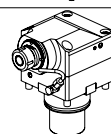
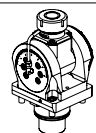
		PAGINA Page Seite
<b>CONTROPUNTA PER CONTROMANDRINO</b> Tailstock for subspindle Gegenspitz fuer Gegenspindel		DW0950.3.00

		PAGINA Page Seite
<p><b>MODULO MOTORIZZATO RADIALE</b> Radial driven tool Radial angetriebenes Werkzeug</p>		DW0010.4.00
<p><b>MODULO MOTORIZZATO RADIALE DISASSATO IN Z 47.5mm</b> Radial driven tool re-directed in Z by 47.5mm Radial angetriebenes Werkzeug achsversetzt in Z um 47.5mm</p>		DW0033.4.10
<p><b>MODULO MOTOR. RADIALE MOLTIPLICATO I=1:2 DISASSATO IN Z 47.5mm</b> Radial geared-up I=1:2 driven tool re-directed in Z by 47.5mm Radial angetriebenes Werkzeug uebersetzt I=1:2 achsversetzt in Z um 47.5mm</p>		DW0033.4.30
<p><b>MODULO MOTORIZZATO RADIALE MOLTIPLICATO I=1:4</b> Radial geared-up I=1:4 driven tool Radial angetriebenes Werkzeug uebersetzt I=1:4</p>		DW0058.4.00
<p><b>MODULO MOTORIZZATO RADIALE ROVESCiato DISASSATO IN Z 187.5</b> Radial inverted driven tool re-directed in Z by 187.5 mm Radial angetriebenes Werkzeug ungekehrt achsversetzt in Z um 187.5 mm</p>		DW0120.4.10
<p><b>MODULO MOTORIZZATO ASSIALE H=60mm</b> Axial driven tool H=60mm Axial angetriebenes Werkzeug H=60mm</p>		DW0150.4.10
<p><b>MODULO MOTORIZZATO ASSIALE MAGGIORATO H=60mm</b> Axial reinforced driven tool H=60mm Axial angetriebenes Werkzeug vergroesset H=60mm</p>		DW0170.4.10
<p><b>MODULO MOTORIZZATO ASSIALE MAGGIORATO H=90mm</b> Axial reinforced driven tool H=90mm Axial angetriebenes Werkzeug vergroesset H=90mm</p>		DW0170.4.20
<p><b>MODULO MOTORIZZATO ASSIALE H=10mm</b> Axial driven tool H=10mm Axial angetriebenes Werkzeug H=10mm</p>		DW0180.4.10
<p><b>MODULO MOTORIZZATO ASSIALE RIDOTTO I=2:1</b> Axial geared-down I=2:1 driven tool Axial angetriebenes Werkzeug untersetzt I=2:1</p>		DW0190.4.10
<p><b>MODULO MOTORIZZATO ASSIALE MOLTIPLICATO I=1:3</b> Axial geared-up I=1:3 driven tool Axial angetriebenes Werkzeug uebersetzt I=1:3</p>		DW0205.4.10
<p><b>MODULO MOTORIZZATO ORIENTABILE +/-90°</b> +/-90° adjustable angle driven tool Angetriebenes Werkzeug schwenkbar +/-90°</p>		DW0339.4.00

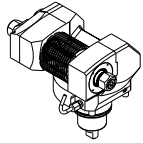
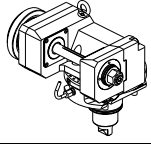
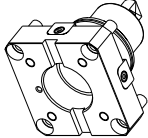
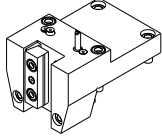
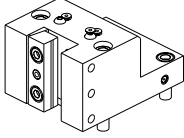
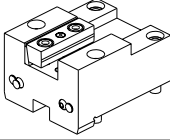
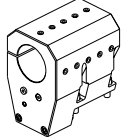
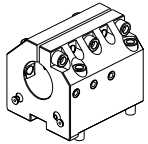

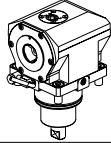
		PAGINA Page Seite
<b>MODULO MOTORIZZATO PORTACREATORE MAGGIORATO</b> Reinforced driven gear hobber Angetriebenes Zahnradwaelzfraes-Werkzeug vergroessert		DW 0340.4.60
<b>MODULO MOTORIZZATO PORTACREATORE (TAGLIA GRANDE)</b> Driven gear hobber (big size) Angetriebenes Zahnradwaelzfraes-Werkzeug (grosse version)		DW 0340.4.80 <b>NEW</b>
<b>INTERFACCIA PER MODULI BIGLIA</b> Biglia tooling adapter cartridge Adapter-Patrone fuer Biglia Werkzeuge		DW 0380.4.00
<b>PORTAUTENSILE RADIALE SINGOLO</b> Radial single static tool Radial Single-Werkzeughalter		DW 0423.4.00
<b>PORTAUTENSILE RADIALE SINGOLO</b> Radial single static tool Radial Single-Werkzeughalter		DW 0423.4.01 <b>NEW</b>
<b>PORTAUTENSILE ASSIALE SINGOLO</b> Axial single static tool Axial Single-Werkzeughalter		DW 0552.4.00
<b>PORTAUTENSILE ASSIALE PER BARENO Ø 80mm H=110mm</b> Axial single boring bar holder Ø80mm H=110mm Axial Bohrhalter Ø80mm H=110mm		DW 0580.4.20 <b>NEW</b>
<b>PORTAUTENSILE ASSIALE PER BARENO Ø 40mm/Ø 1 1/2"/Ø 50mm/Ø 2" H=60mm</b> Axial single boring bar holder Ø40mm/Ø 1 1/2"/Ø 50mm/Ø 2" H=60mm Axial Bohrhalter Ø40mm/Ø 1 1/2"/Ø 50mm/Ø 2" H=60mm		DW 0610.4.20

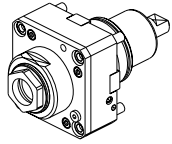
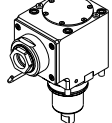
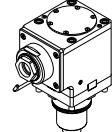
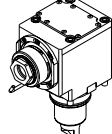
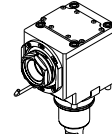
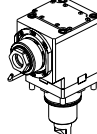
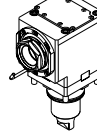
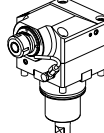
		PAGINA Page Seite
<b>MODULO MOTORIZZATO ASSIALE COROMANT CAPTO®</b> Axial driven tool COROMANT CAPTO® Axial angetriebenes Werkzeug COROMANT CAPTO®		Dw0150.D.40

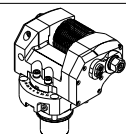
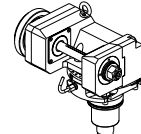
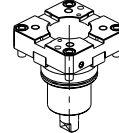
		PAGINA Page Seite
<b>MODULO MOTORIZZATO RADIALE</b> Radial driven tool Radial angetriebenes Werkzeug		DW 0010.5.00
<b>MODULO MOTORIZZATO ASSIALE H=85mm</b> Axial driven tool H=85mm Axial angetriebenes Werkzeug H=85mm		DW 0150.5.10
<b>MODULO MOTORIZZATO ASSIALE H=110mm</b> Axial driven tool H=110mm Axial angetriebenes Werkzeug H=110mm		DW 0150.5.20 <b>NEW</b>
<b>MODULO MOTORIZZATO ASSIALE RIDOTTO l=2:1 H=85mm</b> Axial geared-down l=2:1 driven tool H=85mm Axial angetriebenes Werkzeug untersetzt l=2:1 H=85mm		DW 0190.5.10 <b>NEW</b>
<b>MODULO MOTORIZZATO ASSIALE MTSK RIDOTTO l=2:1 H=85mm</b> Axial MTSK geared-down l=2:1 driven tool H=85mm Axial MTSK angetriebenes Werkzeug untersetzt l=2:1 H=85mm		DW 0190.5.10.K <b>NEW</b>
<b>MODULO MOTORIZZATO ASSIALE RIDOTTO l=2:1 H=110mm</b> Axial geared-down l=2:1 driven tool H=110mm Axial angetriebenes Werkzeug untersetzt l=2:1 H=110mm		DW 0190.5.20 <b>NEW</b>
<b>MODULO MOTORIZZATO ASSIALE MTSK RIDOTTO l=2:1 H=110mm</b> Axial MTSK geared-down l=2:1 driven tool H=110mm Axial MTSK angetriebenes Werkzeug untersetzt l=2:1 H=110mm		DW 0190.5.20.K <b>NEW</b>
<b>MODULO MOTORIZZATO ASSIALE MOLTIPLICATO l=1:3</b> Axial geared-up l=1:3 driven tool Axial angetriebenes Werkzeug uebersetzt l=1:3		DW 0205.5.10
<b>MODULO MOTORIZZATO ORIENTABILE +/-90°</b> +/-90° adjustable angle driven tool Angetriebenes Werkzeug schwenkbar +/-90°		DW 0339.5.00 <b>NEW</b>
<b>MODULO MOTORIZZATO PORTACREATORE MAGGIORATO</b> Reinforced driven gear hobber Angetriebenes Zahnradwaelzfraes-Werkzeug vergroessert		DW 0340.5.60
<b>MODULO MOTORIZZATO PORTACREATORE (TAGLIA GRANDE)</b> Driven gear hobber (big size) Angetriebenes Zahnradwaelzfraes-Werkzeug (grosse version)		DW 0340.5.80 <b>NEW</b>
<b>INTERFACCIA PER MODULI BMT-65 H=33mm</b> BMT-65 tooling adapter cartridge H=33mm Adapter-Patrone fuer BMT-65 werkzeuge H=33mm		DW 0385.5.00

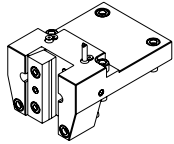
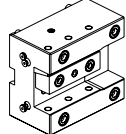
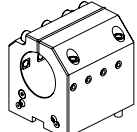
		PAGINA Page Seite
<p><b>PORTAUTENSILE RADIALE SINGOLO</b> Radial single static tool Radial Single-Werkzeughalter</p>		DW0423.5.00
<p><b>PORTAUTENSILE ASSIALE SINGOLO</b> Axial single static tool Axial Single-Werkzeughalter</p>		DW0552.5.00
<p><b>PORTAUTENSILE ASSIALE PER BARENO <math>\varnothing 80\text{mm}</math> / <math>\varnothing 3''</math> H=85mm</b> Axial single boring bar holder <math>\varnothing 80\text{mm}</math> / <math>\varnothing 3''</math> H=85mm Axial Bohrhälter <math>\varnothing 80\text{mm}</math> / <math>\varnothing 3''</math> H=85mm</p>		DW0580.5.20

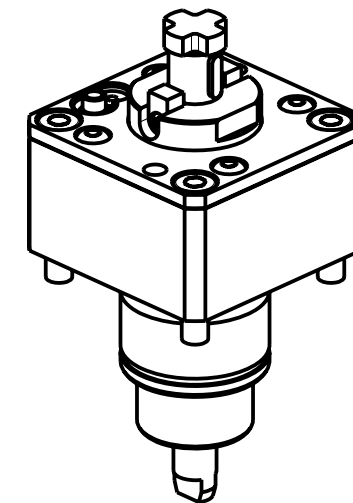
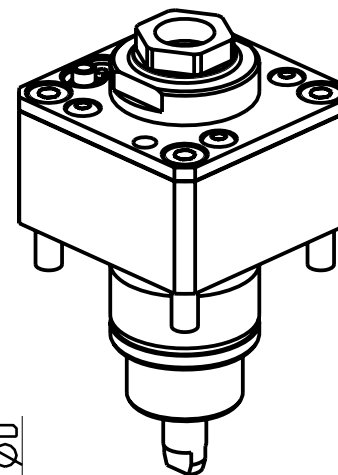
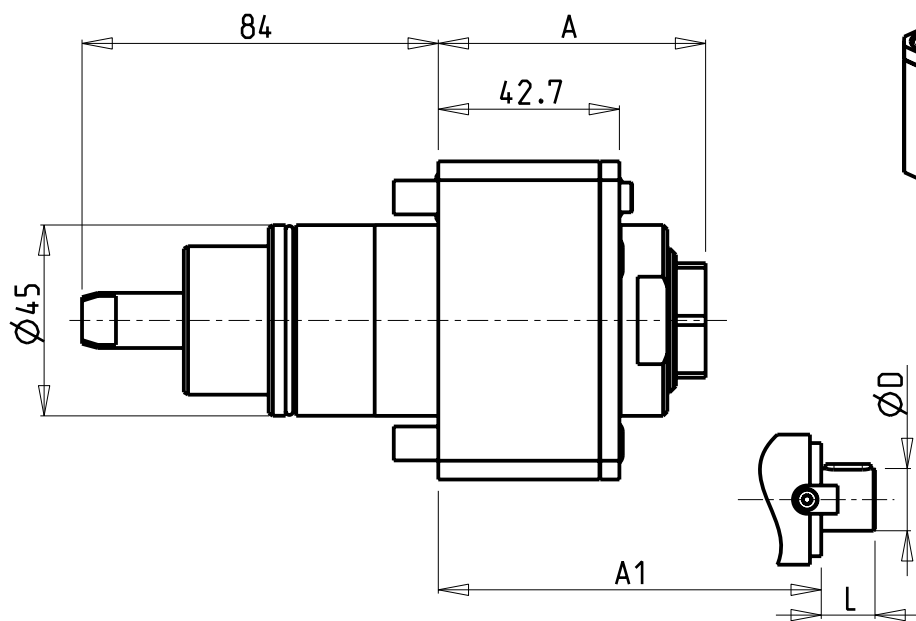
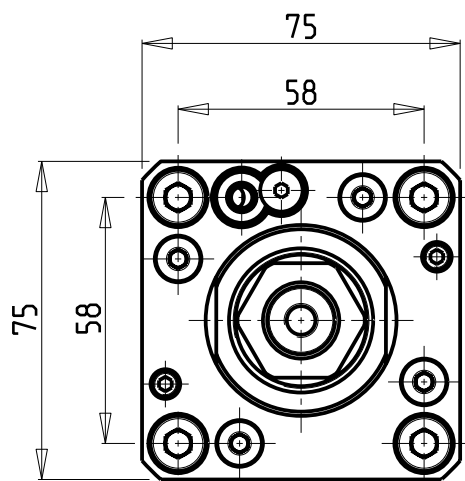

Cod. MT	Mandrino Spindle Spindel	I	RPM	Coppia Max Max Torque Max Drehmoment	Lubrificazione int. Coolant through Innenkuehlung	Lubrificazione est. Ext. coolant Aussenkuehlung	A	A1	D	L	CHIAVI NON INCLUSE Keys not included Schlüssel nicht einbegriffen	
DW 00110120	ER A 20	1:1	6000	35Nm		X	52.73	-	-	-	CHUB22	CHUB36
DW 00110220	ER A 20	1:1	6000	35Nm	P=30bar	X	52.73	-	-	-	CHUB22	CHUB36
DW 00110125	ER A 25	1:1	6000	35Nm		X	63.03	-	-	-	CHUB27	CHUB40
DW 00110225	ER A 25	1:1	6000	35Nm	P=30bar	X	63.03	-	-	-	CHUB27	CHUB40
DW 00111617	Ø16x17	1:1	6000	35Nm		X	-	52	16	17	CH_VTCROCE_M08	CHUB36
DW 00111919	Ø3/4"x3/4"	1:1	6000	35Nm		X		52	3/4"	3/4"	CH_VTCROCE_M08	CHUB36

- Chiave inclusa
- Key included
- Schlüssel inbegriffen

DOOSAN BMT 45  
 MOD: LYNX 220 LM  
 MODULO MOTORIZZATO RADIALE  
 Radial driven tool  
 Radial angetriebenes Werkzeug

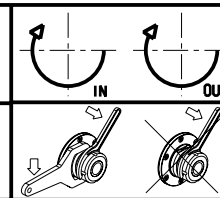

**M.T. srl**  
 Via Casino Albini 480  
 Tel. 0541/956034-957884  
 Fax 0541/956341  
 47842 S. GIOVANNI IN M. (RN)  
 e-mail: mtma@mtmarchetti.com  
 http://www.mtmarchetti.com

PRODUZIONE MODULI ROTANTI



PAGINA DW 0010-1-00

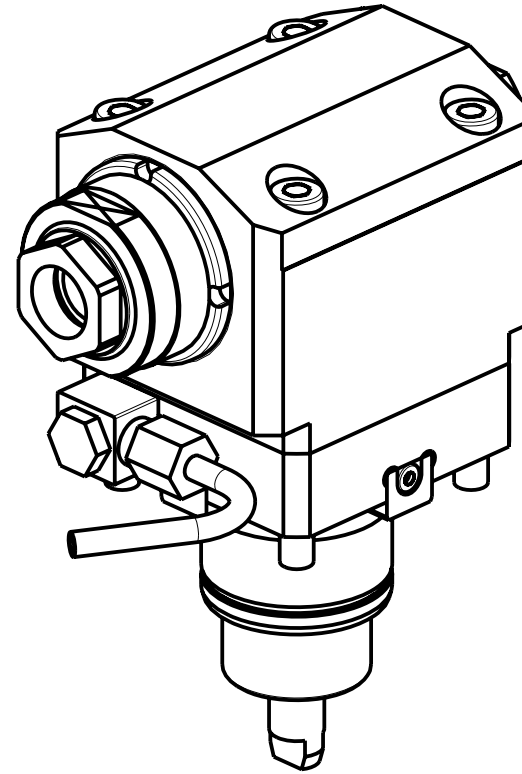
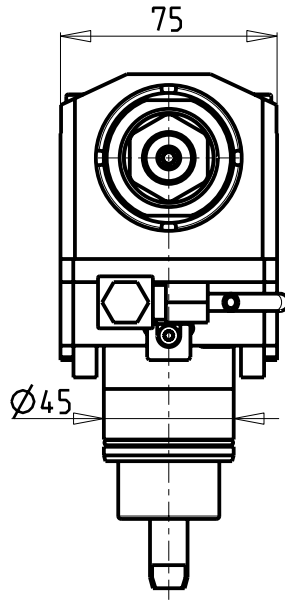
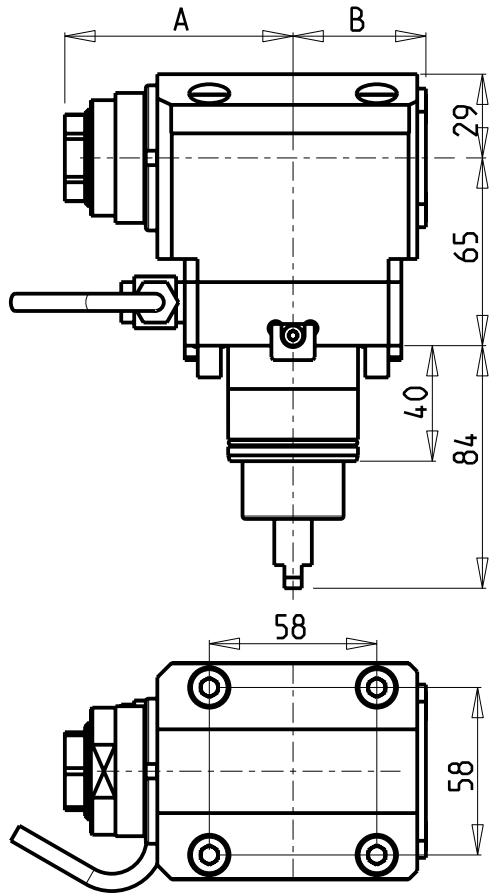

Cod. MT	Mandrino Spindel Spindel	I	RPM	Coppia Max Max Torque Max Drehmoment	Lubrificazione int. Coolant through Innenkuehlung	Lubrificazione est. Ext. coolant Aussenkuehlung	A	B	CHIAVI NON INCLUSE Keys not included Schlüssel nicht inbegriffen	
DW 00130120	ER A 20	1:1	6000	35Nm		X	72.23	46	CHUB22	CHUB36
DW 00130220	ER A 20	1:1	6000	35Nm	P=70bar	X	72.23	56	CHUB22	CHUB36
DW 00130125	ER A 25	1:1	6000	35Nm		X	79.03	46	CHUB27	CHUB36
DW 00130225	ER A 25	1:1	6000	35Nm	P=70bar	X	79.03	56	CHUB27	CHUB36

DOOSAN BMT 45  
 MOD: LYNX 220 LM  
 MODULO MOTORIZZATO ASSIALE  
 Axial driven tool  
 Axial angetriebenes Werkzeug

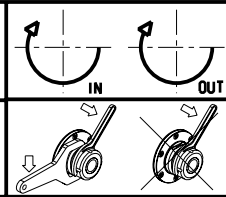

**M.T. srl**  
 Via Casino Albini 480  
 Tel. 0541/956034-957884  
 Fax 0541/956341  
 47842 S. GIOVANNI IN M. (RN)  
 e-mail: mtma@mtmarchetti.com  
 http://www.mtmarchetti.com

PRODUZIONE MODULI ROTANTI



PAGINA DW 0150-1-00



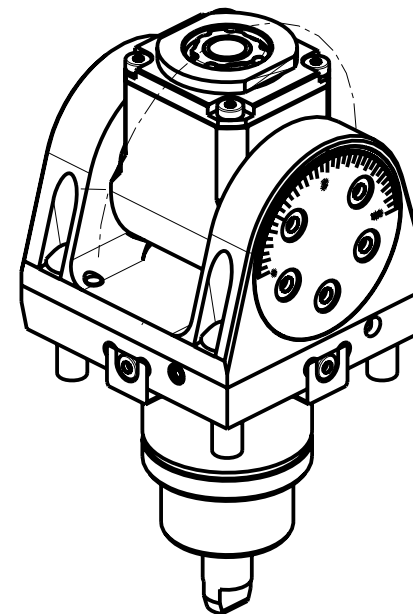
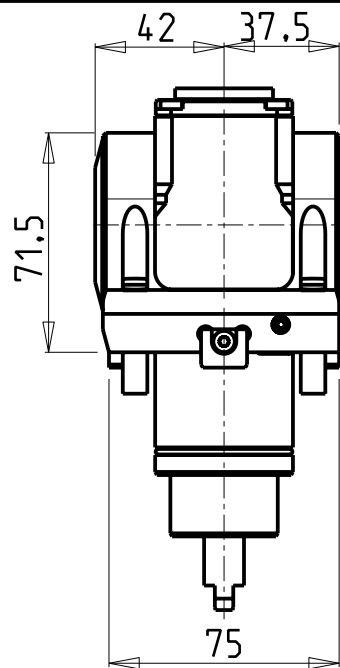
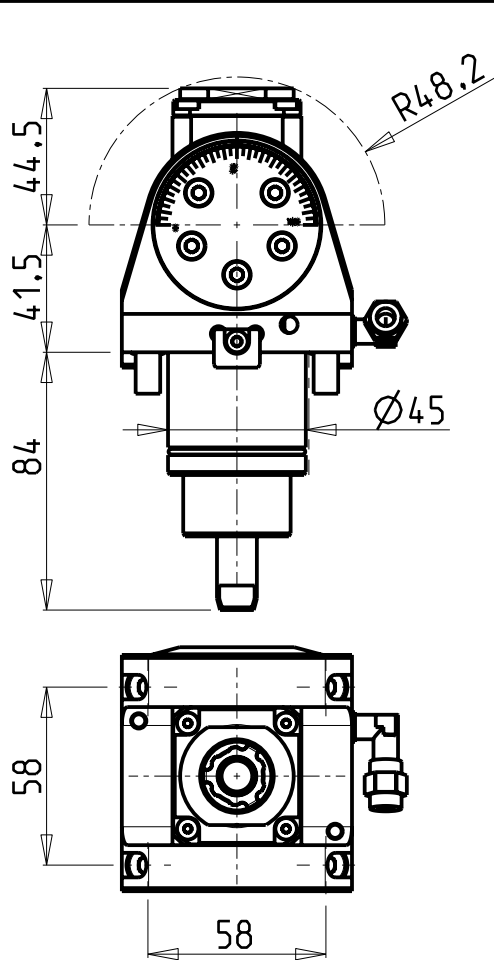

Cod. MT	Mandrino Spindle Spindel	I	RPM	Coppia Max Max Torque Max Drehmoment	Reversibile lato mandrino/contromandrino Reversible sub/main spindle side Umkehrbare Spindel-seite/ Gegenspindel-seite	Lubrificazione est. Ext. coolant Aussenkuehlung	CHIAVI INCLUSE Keys included Schluessel inbegriffen			
DW00040116	ER A 16	1:1	6000	20Nm	X	X	CHUB19_SP3	CHUB32	CHESL05	CHTAER16ZC

DOOSAN BMT 45  
MOD: LYNX 220 LM

MODULO MOTORIZZATO ORIENTABILE ±90°  
±90° adjustable angle driven tool  
Angetriebenes Werkzeug schwenkbar ±90°

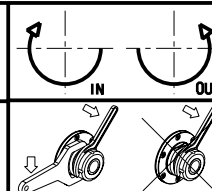

**M.T. srl**

Via Casino Albini 480  
Tel. 0541/956034-957884  
Fax 0541/956341

47842 S. GIOVANNI IN M. (RN)  
e-mail: mtma@mtmarchetti.com  
http://www.mtmarchetti.com

PRODUZIONE MODULI ROTANTI



PAGINA DW0335-1-00

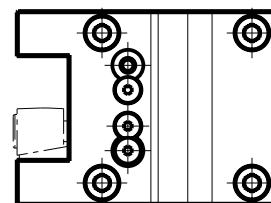
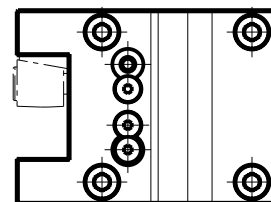
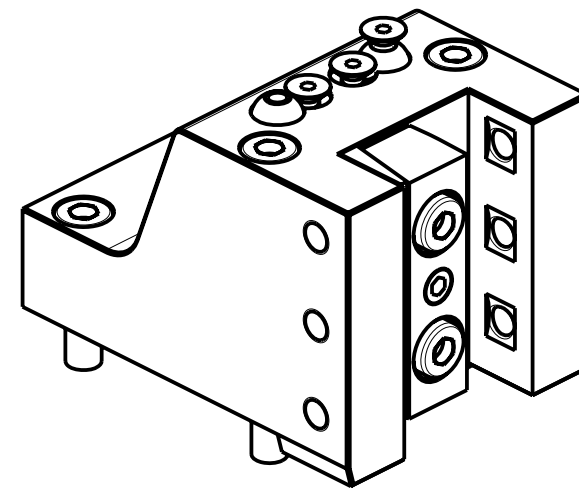
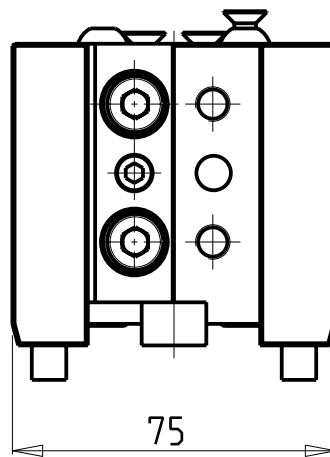
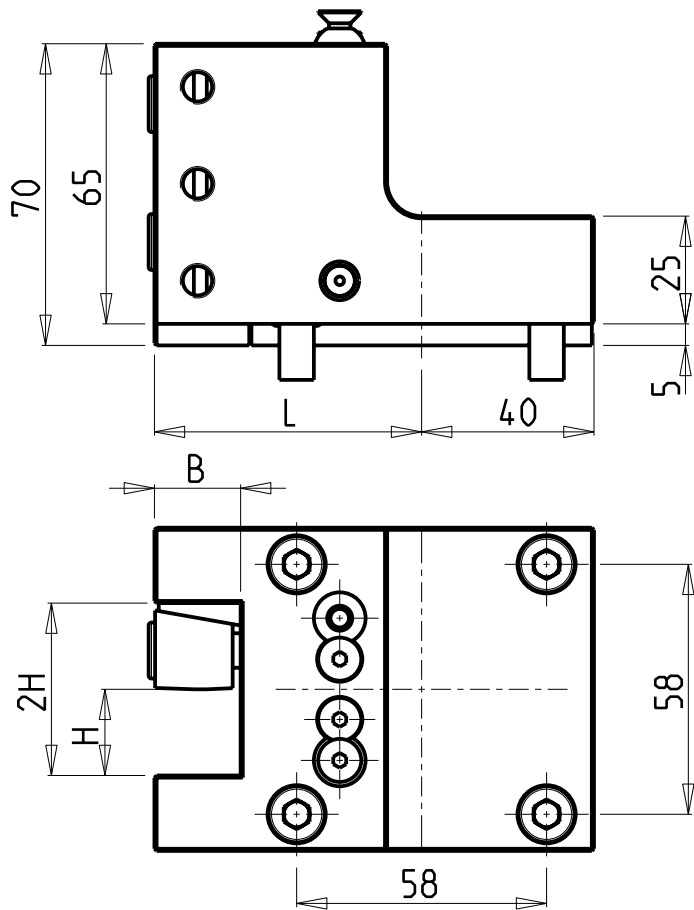

Cod. MT	N°Utensili N°Tools N°Werkzeuge	Reversibile lato mandrino/contromandrino Reversible sub/main spindle side Umkehrbare Spindel-seite/ Gegenspindel-seite	Misure Dimensions Masse	L	B	H
DW 00312000	1/2	X	mm	62	20	20
DW 00312010	1/2	X	mm	85	20	20
DW 00311905	1/2	X	Inch	62	3/4"	3/4"

DOOSAN BMT 45  
 MOD: LYNX 220 LM  
 PORTAUTENSILE RADIALE SINGOLO  
 Radial single static tool  
 Radial Single-Werkzeughalter

**M.T. srl**  
 Via Casino Albini 480  
 Tel. 0541/956034-957884  
 Fax 0541/956341  
 47842 S. GIOVANNI IN M. (RN)  
 e-mail: mtma@mtmarchetti.com  
 http://www.mtmarchetti.com

PRODUZIONE MODULI ROTANTI  
  
 PAGINA DW 0420-1-00

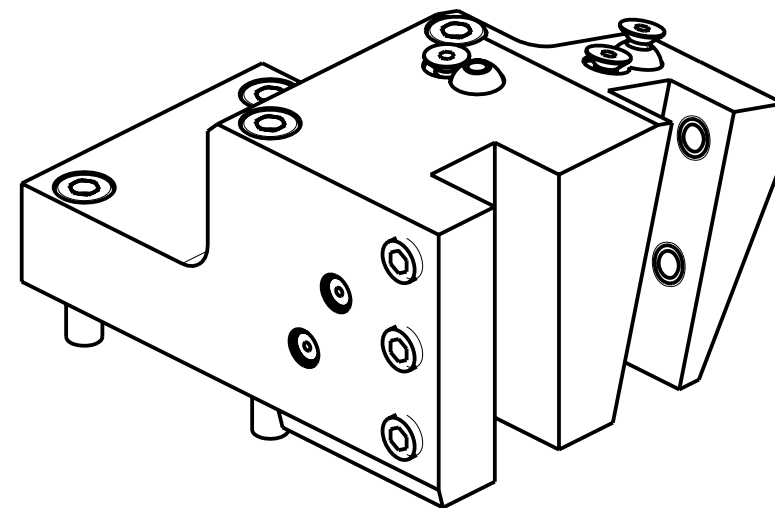
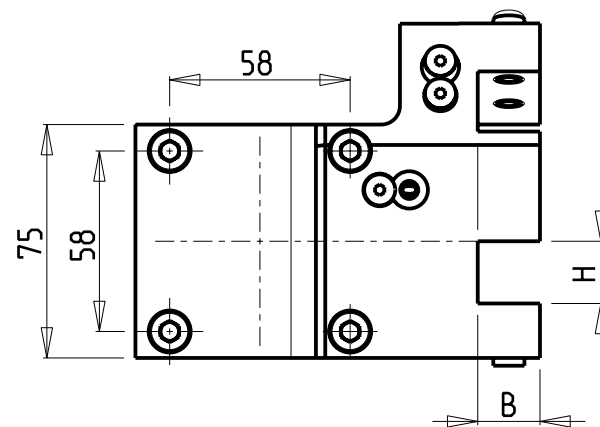
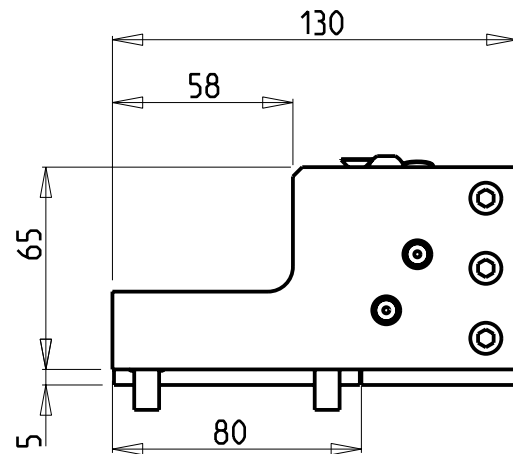
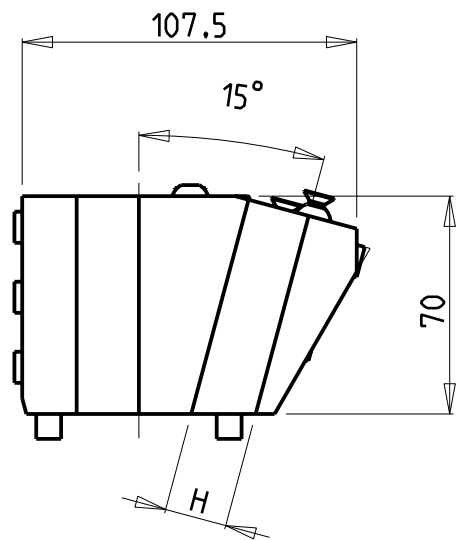

Cod. MT	N°Utensili N°Tools N°Werkzeuge	Misure Dimensions Masse	H	B
DW00532000	2	mm	20	20
DW00531905	2	Inch	3/4"	3/4"

DOOSAN BMT 45  
MOD: LYNX 220 LM

PORTAUTENSILE RADIALE MULTIPLO  
Radial multiple static tool  
Radial Mehrfach-Halter

**M.T. srl**

Via Casino Albini 480  
Tel. 0541/956034-957884  
Fax 0541/956341  
47842 S. GIOVANNI IN M. (RN)  
e-mail: mtma@mtmarchetti.com  
http://www.mtmarchetti.com

PRODUZIONE MODULI ROTANTI



PAGINA DW0440-1-50

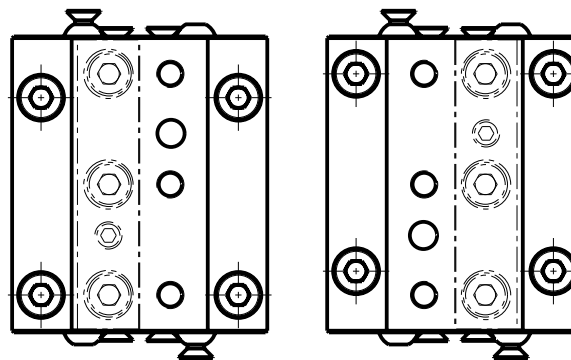
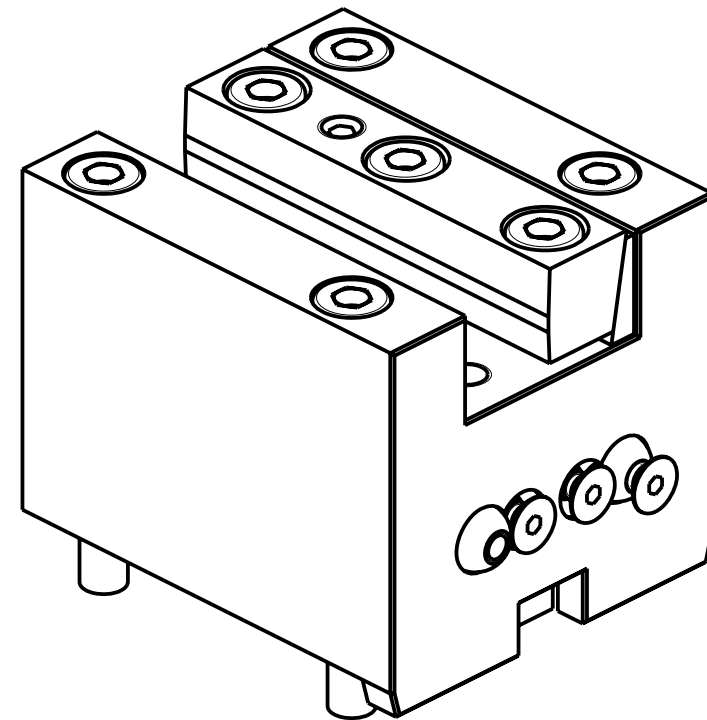
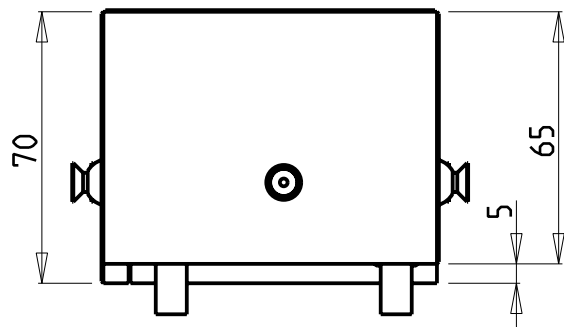
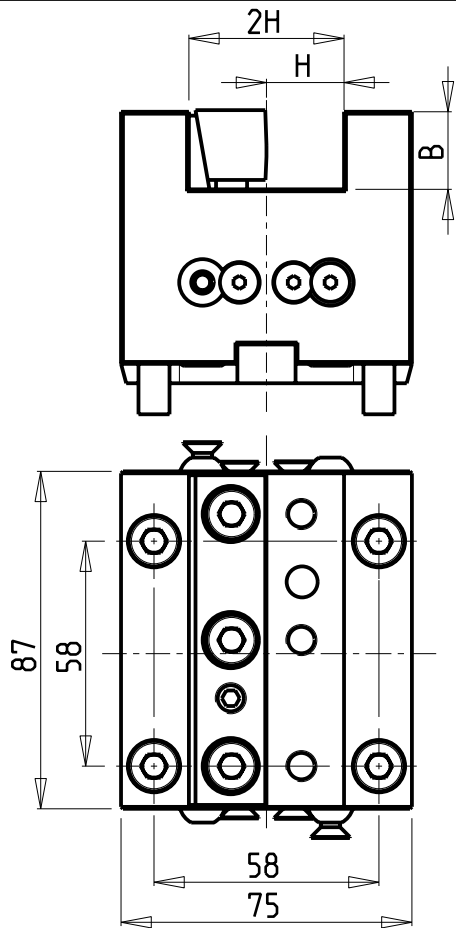

Cod. MT	N°Utensili N°Tools N°Werkzeuge	Reversibile lato mandrino/contromandrino Reversible sub/main spindle side Umkehrbare Spindel-seite/ Gegenspindel-seite	Misure Dimensions Masse	B	H
DW 00282000	1	X	mm	20	20
DW 00281905	1	X	Inch	3/4"	3/4"

DOOSAN BMT 45  
MOD: LYNX 220 LM

PORTAUTENSILE ASSIALE SINGOLO  
Axial single static tool  
Axial Single-Werkzeughalter

**M.T. srl**

Via Casino Albini 480  
Tel. 0541/956034-957884  
Fax 0541/956341  
47842 S. GIOVANNI IN M. (RN)  
e-mail: mtma@mtmarchetti.com  
http://www.mtmarchetti.com

PRODUZIONE MODULI ROTANTI



PAGINA DW 0550-1-00

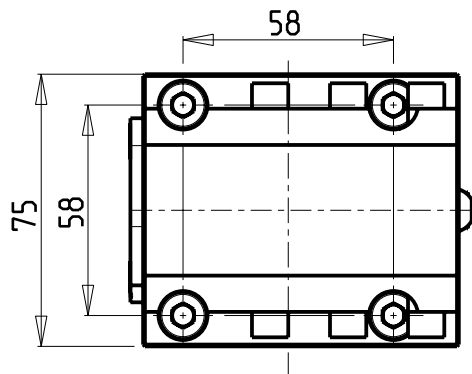
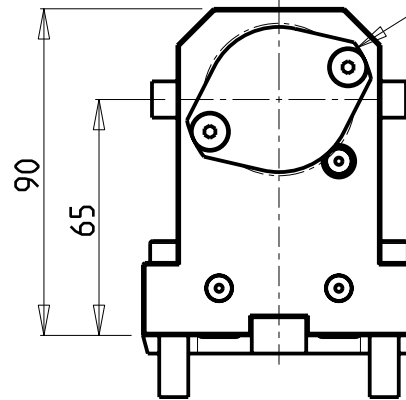
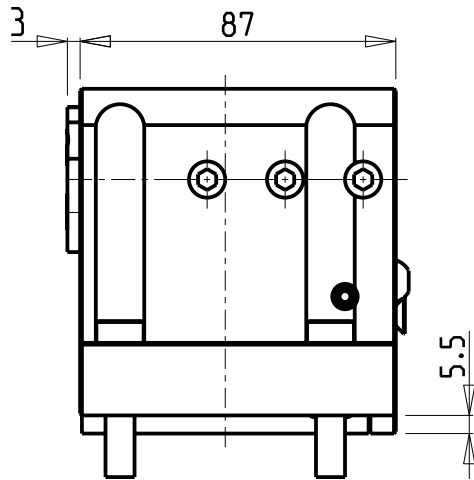
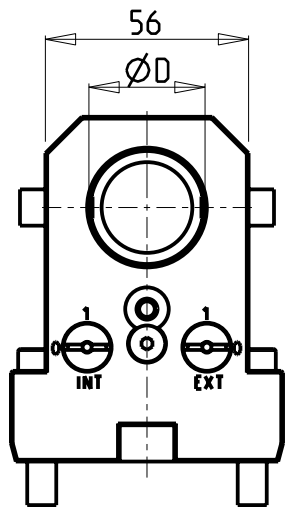

KIT ADDUZIONE INTERNA (OPZIONALE)  
 KIT FOR INTERNAL COOLANT (OPTIONAL)  
 KIT FUER INTERNE KUEHLMITTELZUFUHR (OPTIONAL)  
 Ø32-Ø1 1/4" KIT1000001

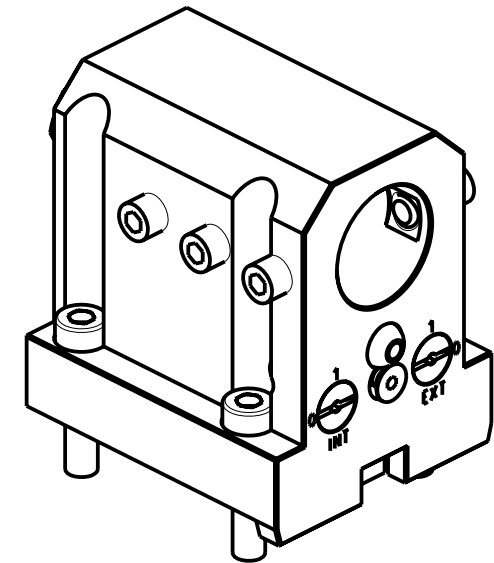

Cod. MT	N°Utensili N°Tools N°Werkzeuge	Reversibile lato mandrino/contromandrino Reversible sub/main spindle side Umkehrbare Spindel-seite/ Gegenspindel-seite	Lubrificazione int. opzionale Coolant through optional Innenkuehlung Optional	Lubrificazione est. Ext. coolant Aussenkuehlung	Misure Dimensions Masse	D
DW 00293200	1	X	X	X	mm	32
DW 00293175	1	X	X	X	Inch	1 1/4"

PER BOCCOLE DI RIDUZIONE VEDI PAG. TBL150-1-00  
 FOR REDUCING BUSHINGS SEE PAGE TBL150-1-00  
 FÜR REDUZIERBUCHSE SIEHE SEITE TBL150-1-00

DOOSAN BMT 45  
 MOD: LYNX 220 LM

PORTAUTENSILE ASSIALE PER BARENO Ø32mm / Ø1 1/4" H=65mm  
 Axial single boring bar holder Ø32mm / Ø1 1/4" H=65mm  
 Axial Bohrhälter Ø32mm / Ø1 1/4" H=65mm

**M.T. srl**

Via Casino Albini 480  
 Tel. 0541/956034-957884  
 Fax 0541/956341  
 47842 S. GIOVANNI IN M. (RN)  
 e-mail: mtma@mtmarchetti.com  
 http://www.mtmarchetti.com

PRODUZIONE MODULI ROTANTI



PAGINA DW 0650-1-10

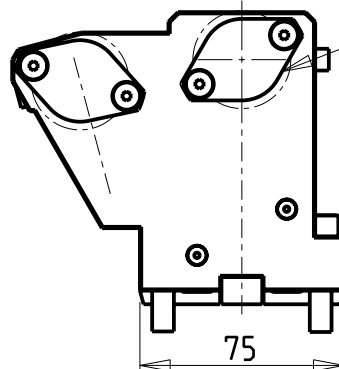
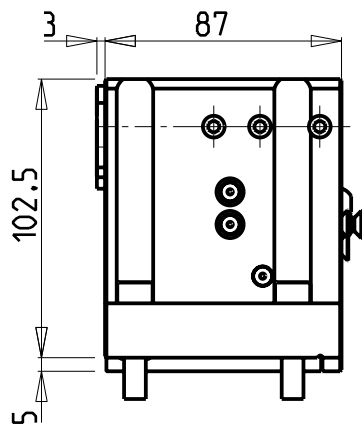
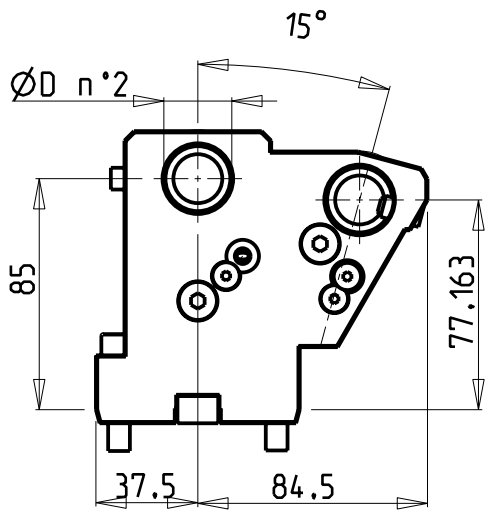

KIT ADDUZIONE INTERNA (OPZIONALE)  
 KIT FOR INTERNAL COOLANT (OPTIONAL)  
 KIT FÜR INTERNE KÜHLMITTELZUFUHR (OPTIONAL)  
 Ø25-Ø1" cod. KIT1000006

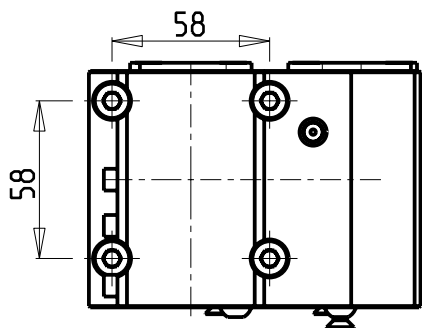
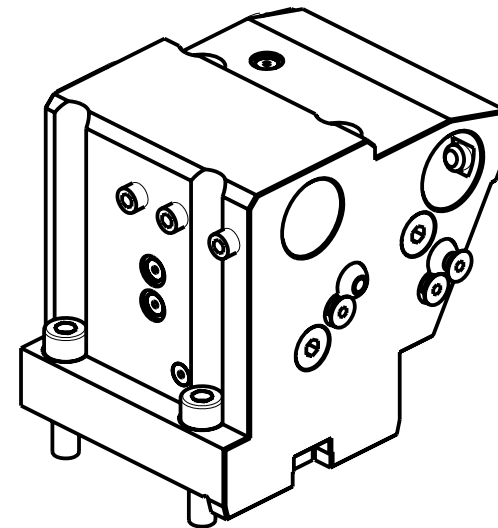

PER BOCCOLE DI RIDUZIONE VEDI PAG. TBL150-1-00  
 FOR REDUCING BUSHINGS SEE PAGE TBL150-1-00  
 FÜR REDUZIERBUCHSE SIEHE SEITE TBL150-1-00

Cod. MT	N°Utensili N°Tools N°Werkzeuge	Reversibile lato mandrino/contromandrino Reversible sub/main spindle side Umkehrbare Spindel-seite/ Gegenspindel-seite	Lubrificazione int. opzionale Coolant through optional Innenkuehlung Optional	Lubrificazione est. Ext. coolant Aussehenkuehlung	Misure Dimensions Masse	D
DW 00522500	2	X	X	X	mm	25
DW 00522540	2	X	X	X	Inch	1"

DOOSAN BMT 45  
 MOD: LYNX 220 LM

PORTAUTENSILE ASSIALE PER BARENO 2 POSIZIONI Ø25mm / Ø1"  
 Axial double boring bar holder Ø25mm / Ø1"  
 Axial Bohrhälter 2 Positionen Ø25mm / Ø1"

**M.T. srl**

Via Casino Albini 480  
 Tel. 0541/956034-957884  
 Fax 0541/956341  
 47842 S. GIOVANNI IN M. (RN)  
 e-mail: mtma@mtmarchetti.com  
 http://www.mtmarchetti.com

PRODUZIONE MODULI ROTANTI



PAGINA DW 0864-1-50

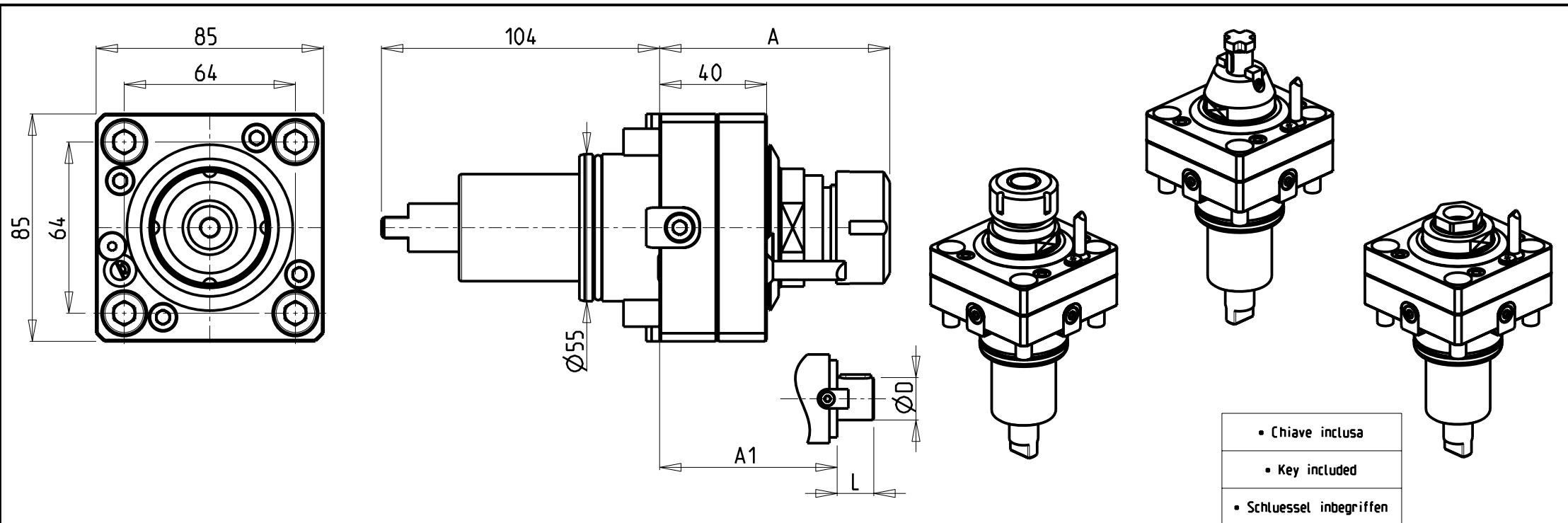

- Chiave inclusa
- Key included
- Schluessel inbegriffen

Cod. MT	Cod. EPPINGER	Mandrino Spindle Spindel	I	RPM	Coppia Max Max Torque Max Drehmoment	Lubrificazione int. Coolant through Innenkuehlung	Lubrificazione est. Ext. coolant Aussenkuehlung	A	A1	D	L	CHIAVI NON INCLUSE Keys not included Schluessel nicht einbegriffen	
0271325	-	ER25	1:1	6000	50Nm		X	86.06	-	-	-	CHSTER25	CHUB40 o 0270018
0270225	-	ER25	1:1	6000	50Nm	P=30bar	X	86.06	-	-	-	CHSTER25	CHUB40 o 0270018
0271525	7.070.679	ER A 25	1:1	6000	50Nm		X	63.03	-	-	-	CHUB27	CHUB40 o 0270018
0271025	-	ER A 25	1:1	6000	50Nm	P=30bar	X	63.03	-	-	-	CHUB27	CHUB40 o 0270018
0272232	-	ER32	1:1	6000	50Nm		X	85.06	-	-	-	CHSTER32	CHUB40 o 0270018
0272332	-	ER32	1:1	6000	50Nm	P=30bar	X	85.16	-	-	-	CHSTER32	CHUB40 o 0270018
0271617	-	Ø16x17	1:1	6000	50Nm		X	-	70	16	17	CH_VTCROCE_M08	CHUB40 o 0270018
0272219	-	Ø22x19	1:1	6000	50Nm		X	-	70	22	19	CH_VTCROCE_M10	CHUB40 o 0270018

### DOOSAN BMT 55

MOD: PUMA 230-240M/MS-280LM - PUMA 1500-2000-2500M/MS/Y/SY - LINX 300 M - PUMA 2100 SERIE  
PUMA TT1500-TT1800MS/SY - PUMA TL2000-2500 (M) - MX1600/2100TS - PUMA GT2100 M

MODULO MOTORIZZATO RADIALE  
Radial driven tool  
Radial angetriebenes Werkzeug

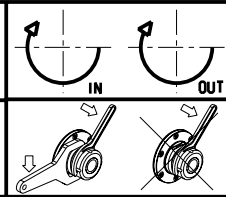

**M.T. srl**  
Via Casino Albini 480  
Tel. 0541/956034-957884  
Fax 0541/956341  
47842 S. GIOVANNI IN M. (RN)  
e-mail: mtma@mtmarchetti.com  
http://www.mtmarchetti.com

PRODUZIONE MODULI ROTANTI



PAGINA DW 0010-2-00

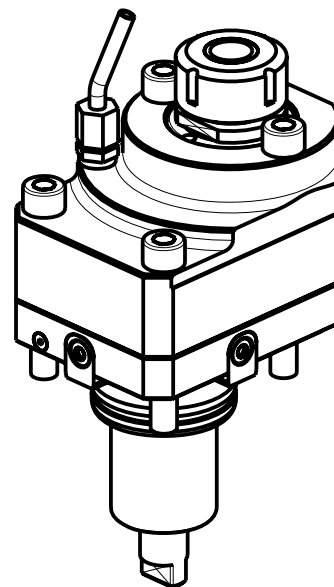
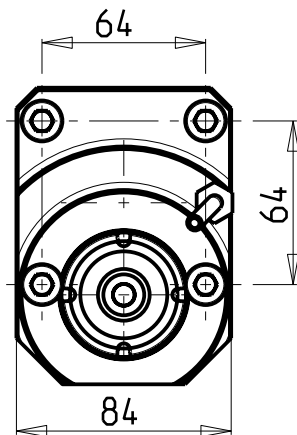
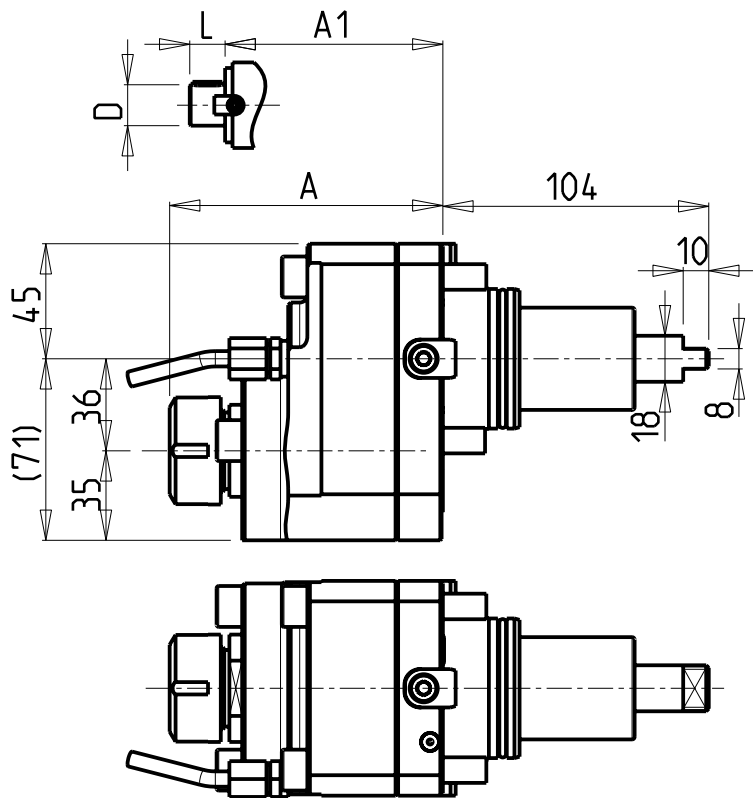

**ATTENZIONE - ATTENTION - ACHTUNG**

- VERIFICARE LE MISURE DI INGOMBRO PER POSSIBILE INTERFERENZA SU ALCUNI MODELLI DI MACCHINE
- Please check the overall sizes for possible interferences on some machine models
- Bitte überprüfen sie das ausmass um mögliche interferenzen auf einigen maschinen modellen zu vermeiden

- Chiave inclusa
- Key included
- Schluessel inbegriffen

Cod. MT	Mandrino Spindle Spindel	I	RPM	Coppia Max Max Torque Max Drehmoment	Reversibile lato mandrino/contromandrino Reversible sub/main spindle side Umkehrbare Spindel-seite/ Gegenspindel-seite	Lubrificazione est. Ext. coolant Aussenkuehlung	A	A1	D	L	CHIAVI NON INCLUSE Keys not included Schluessel nicht einbegriffen	
											CH_VTCROCE_M08	MNL0210007
0720025	ER25	1:1	6000	50Nm	X	X	106.86	-	-	-	CHSTER25	MNL0210007
0720032	ER32	1:1	6000	50Nm	X	X	120.56	-	-	-	CHSTER32	MNL0210007
0720016	∅16x17	1:1	6000	50Nm	X	X	-	88.5	16	17	CH_VTCROCE_M08	MNL0210007
0720022	∅22x19	1:1	6000	50Nm	X	X	-	90.5	22	19	CH_VTCROCE_M10	MNL0210007
0720027	∅27x21	1:1	6000	50Nm	X	X	-	92.5	27	21	CH_VTCROCE_M12	MNL0210007

**DOOSAN BMT 55**

MOD: PUMA 230-240M/MS-280LM - PUMA 1500-2000-2500M/MS/Y/SY - LINX 300 M - PUMA 2100 SERIE  
PUMA TT1500-TT1800MS/SY - PUMA TL2000-2500 (M) - MX1600/2100TS - PUMA GT2100 M

MODULO MOTORIZZATO RADIALE DISASSATO IN Z 36mm

Radial driven tool re-directed in Z by 36mm

Radial angetriebenes Werkzeug achsversetzt in Z um 36mm

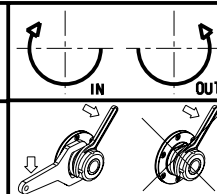

**M.T. srl**

Via Casino Albini 480  
Tel. 0541/956034-957884

Fax 0541/956341

47842 S. GIOVANNI IN M. (RN)

e-mail: mtma@mtmarchetti.com

http://www.mtmarchetti.com

PRODUZIONE MODULI ROTANTI



PAGINA DW 0030-2-10



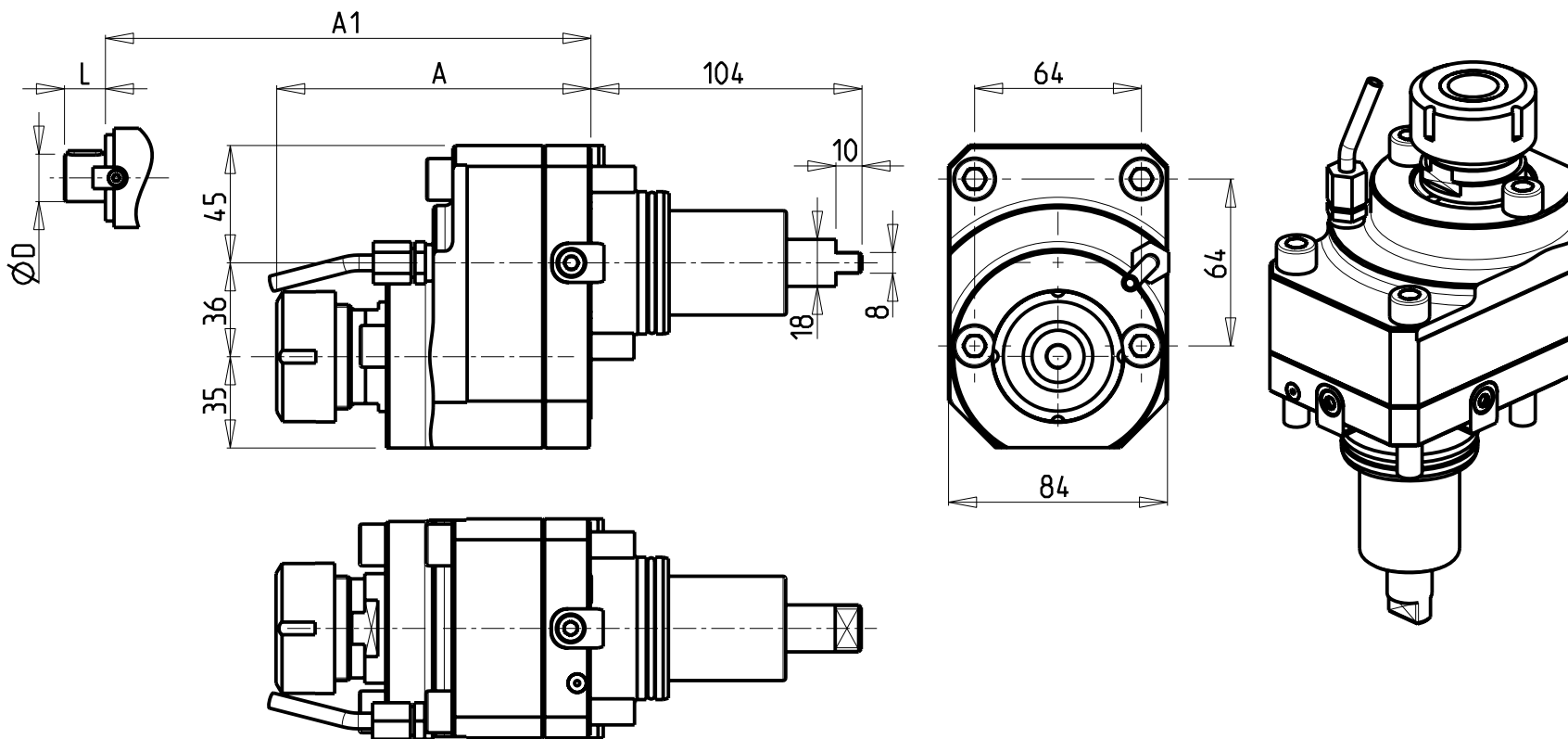

ATTENZIONE - ATTENTION - ACHTUNG

- VERIFICARE LE MISURE DI INGOMBRO PER POSSIBILE INTERFERENZA SU ALCUNI MODELLI DI MACCHINE
- Please check the overall sizes for possible interferences on some machine models
- Bitte überprüfen sie das ausmass um mögliche interferenzen auf einigen maschinen modellen zu vermeiden

- Chiave inclusa
- Key included
- Schluessel inbegriffen

Cod. MT	Mandrino Spindle Spindel	I	RPM	Coppia Max Max Torque Max Drehmoment	Reversibile lato mandrino/contromandrino Reversible sub/main spindle side Umkehrbare Spindel-seite/ Gegenspindel-seite	Lubrificazione est. Ext. coolant Aussenkuehlung	A	A1	D	L	CHIAVI NON INCLUSE Keys not included Schluessel nicht einbegriffen	
0722132	ER32	2:1	3000	65Nm	X	X	120.56	-	-	-	CHSTER32	MNL0210007
0722116	Ø16x17	2:1	3000	65Nm	X	X	-	88.5	16	17	CH_VTCROCE_M08	MNL0210007
0722122	Ø22x19	2:1	3000	65Nm	X	X	-	90.5	22	19	CH_VTCROCE_M10	MNL0210007
0722127	Ø27x21	2:1	3000	65Nm	X	X	-	92.5	27	21	CH_VTCROCE_M12	MNL0210007

## DOOSAN BMT 55

MOD: PUMA 230-240M/MS-280LM - PUMA 1500-2000-2500M/MS/Y/SY - LINX 300 M - PUMA 2100 SERIE  
PUMA TT1500-TT1800MS/SY - PUMA TL2000-2500 (M) - MX1600/2100TS - PUMA GT2100 M

MODULO MOTORIZZATO RADIALE RIDOTTO I=2:1 DISASSATO IN Z 36mm

Radial geared-down I=2:1 driven tool re-directed in Z by 36mm

Radial angetriebenes Werkzeug untersetzt I=2:1 achsversetzt in Z um 36mm

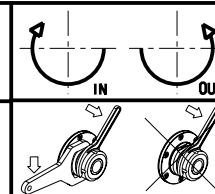

**M.T. srl**

Via Casino Albini 480  
Tel. 0541/956034-957884  
Fax 0541/956341

47842 S. GIOVANNI IN M. (RN)  
e-mail: mtma@mtmarchetti.com  
http://www.mtmarchetti.com

PRODUZIONE MODULI ROTANTI



PAGINA DW 0030-2-20

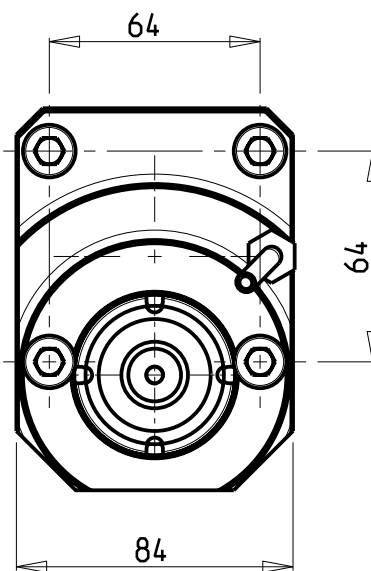
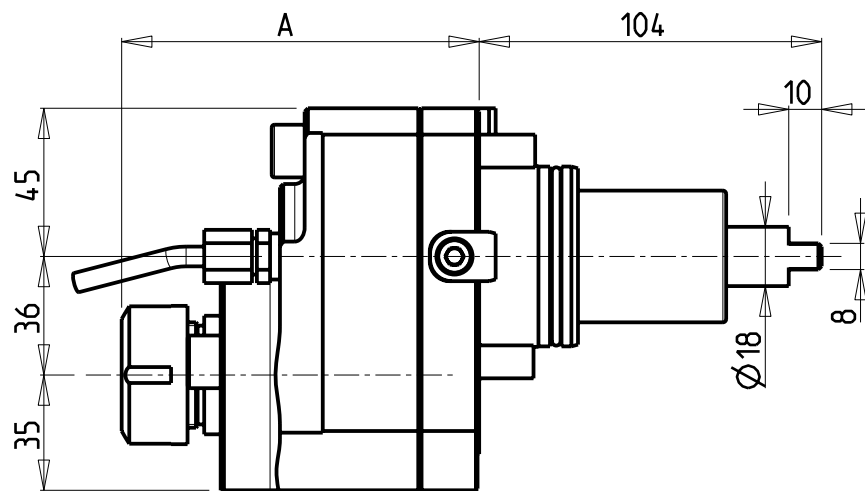

**ATTENZIONE - ATTENTION - ACHTUNG**

- VERIFICARE LE MISURE DI INGOMBRO PER POSSIBILE INTERFERENZA SU ALCUNI MODELLI DI MACCHINE
- Please check the overall sizes for possible interferences on some machine models
- Bitte überprüfen sie das ausmass um mögliche interferenzen auf einigen maschinen modellen zu vermeiden

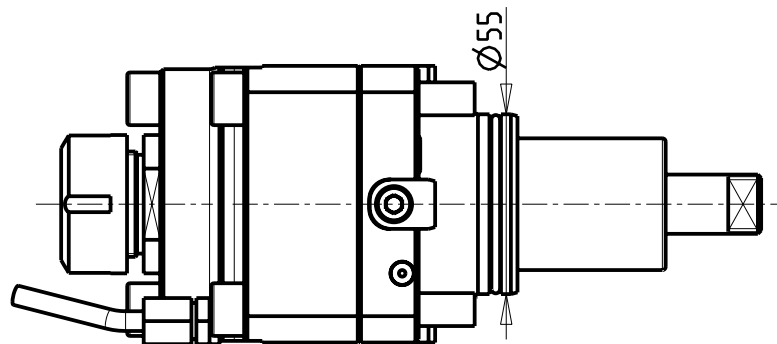
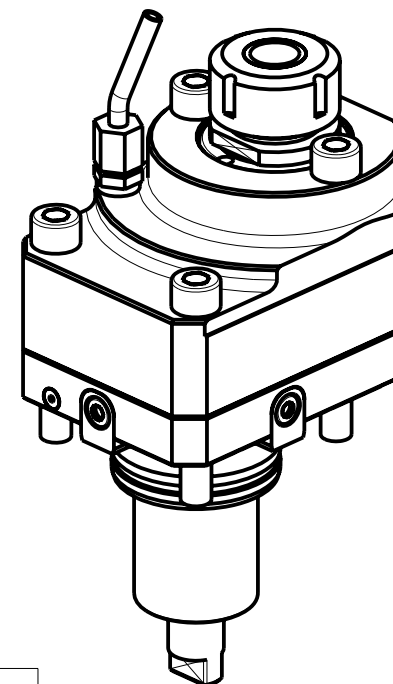

Cod. MT	Mandrino Spindel Spindel	I	RPM	Coppia Max Max Torque Max Drehmoment	Reversibile lato mandrino/contromandrino Reversible sub/main spindle side Umkehrbare Spindel-seite/ Gegenspindel-seite	Lubrificazione est. Ext. coolant Aussenkuehlung	A	CHIAVI NON INCLUSE Keys not included Schluessel nicht einbegriffen
0721225	ER25	1:2	12000	30Nm	X	X	108.56	CHSTER25 MNL0210007

**DOOSAN BMT 55**

MOD: PUMA 230-240M/MS-280LM - PUMA 1500-2000-2500M/MS/Y/SY - LINX 300 M - PUMA 2100 SERIE  
 PUMA TT1500-TT1800MS/SY - PUMA TL2000-2500 (M) - MX1600/2100TS - PUMA GT2100 M

MODULO MOTORIZZATO RADIALE MOLTIPLICATO I=1:2 DISASSATO IN Z 36mm

Radial geared-up I=1:2 driven tool re-directed in Z by 36mm

Radial angetriebenes Werkzeug uebersezt I=1:2 achsversetzt in Z um 36mm

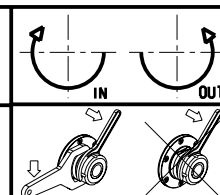

**M.T. srl**

Via Casino Albini 480  
 Tel. 0541/956034-957884

Fax 0541/956341

47842 S. GIOVANNI IN M. (RN)

e-mail: mtma@mtmarchetti.com

http://www.mtmarchetti.com

PRODUZIONE MODULI ROTANTI



PAGINA DW 0030-2-30

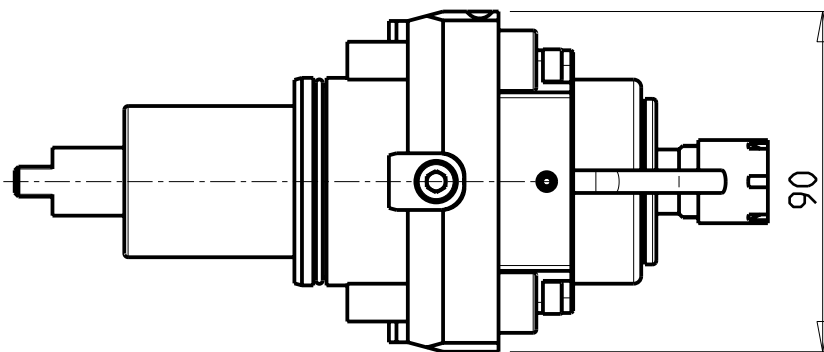
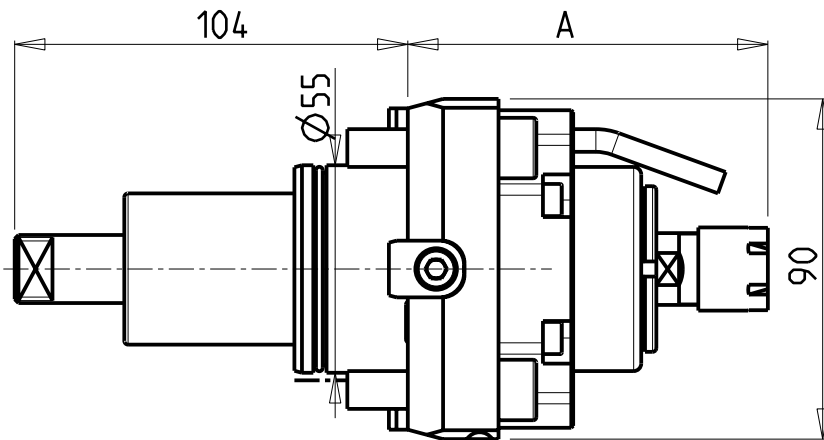
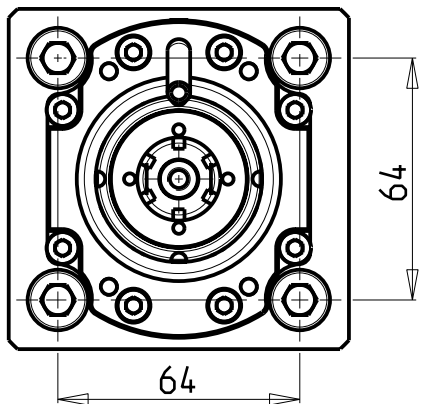

### ATTENZIONE - ATTENTION - ACHTUNG

- Per lo smontaggio degli utensili utilizzare sempre la chiave di contrasto come indicato nel manuale d'uso.
- For disassembly of the tools use always the contrast key as mentioned in the user instructions.
- Fuer das Abmontieren der Werkzeuge immer den Gegenschlüssel benutzen wie in der Bedienungsanleitung erwäehnt.

### ATTENZIONE - ATTENTION - ACHTUNG

- VERIFICARE LE MISURE DI INGOMBRO PER POSSIBILE INTERFERENZA SU ALCUNI MODELLI DI MACCHINE
- Please check the overall sizes for possible interferences on some machine models
- Bitte überprüfen sie das ausmass um mögliche interferenzen auf einigen maschinen modellen zu vermeiden

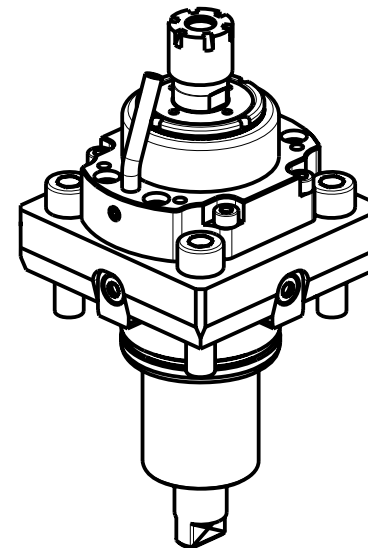

### ATTENZIONE - ATTENTION - ACHTUNG

- PRIMA DI UTILIZZARE IL MOTORIZZATO CONSULTARE LE ISTRUZIONI ALLEGATE!
- BEFORE USING THE DRIVEN TOOL, PLEASE CHECK THE ENCLOSED INSTRUCTION SHEET!
- VOR DER BENUTZUNG DES ANGETRIEBENEN WERKZEUGES, DIE BEILIEGENDEN INSTRUKTIONEN DURCHLESEN!

Cod. MT	Mandrino Spindle Spindel	I	RPM	Coppia Max Max Torque Max Drehmoment	Lubrificazione int. Coolant through Innenkuehlung	Lubrificazione est. Ext. coolant Aussenkuehlung	A	CHIAVI INCLUDE Keys included Schluessel einbegriffen	
DW 00600116	ER16	1:5.625	22500	6Nm		X	95.25	CHMNER16	CHUB17
DW 00600111	ER11	1:5.625	22500	6Nm	P=30bar	X	107.45	CHMNER11	CHUB11

## DOOSAN BMT 55

MOD: PUMA 230-240M/MS-280LM - PUMA 1500-2000-2500M/MS/Y/SY - LINX 300 M - PUMA 2100 SERIE  
PUMA TT1500-TT1800MS/SY - PUMA TL2000-2500 (M) - MX1600/2100TS - PUMA GT2100 M

MODULO MOTORIZZATO RADIALE MOLTIPLICATO I=1:5.625

Radial geared-up I=1:5.625 driven tool

Radial angetriebenes Werkzeug uebersetzt I=1:5.625

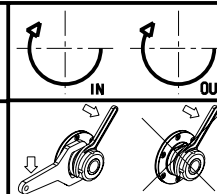

### M.T. srl

Via Casino Albini 480  
Tel. 0541/956034-957884  
Fax 0541/956341

47842 S. GIOVANNI IN M. (RN)  
e-mail: mtma@mtmarchetti.com  
http://www.mtmarchetti.com

PRODUZIONE MODULI ROTANTI



PAGINA DW 0060-2-00

**ATTENZIONE - ATTENTION - ACHTUNG**

- Per lo smontaggio degli utensili utilizzare sempre la chiave di contrasto come indicato nel manuale d'uso.
- For disassembly of the tools use always the contrast key as mentioned in the user instructions.
- Fuer das Abmontieren der Werkzeuge immer den Gegenschlüssel benutzen wie in der Bedienungsanleitung erwäehnt.

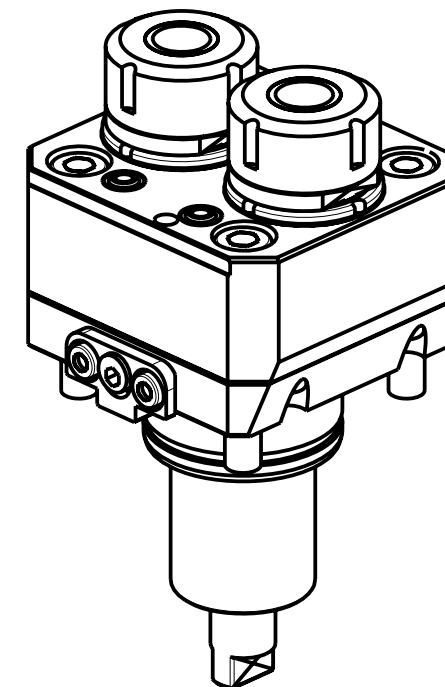
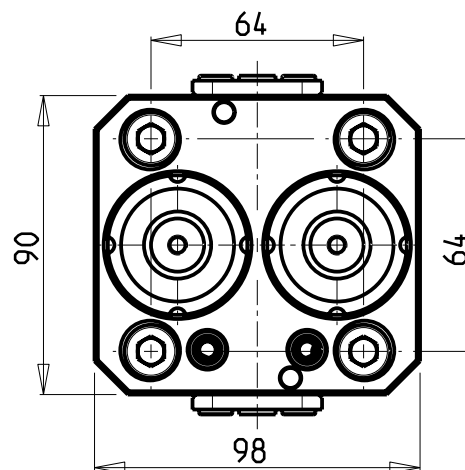
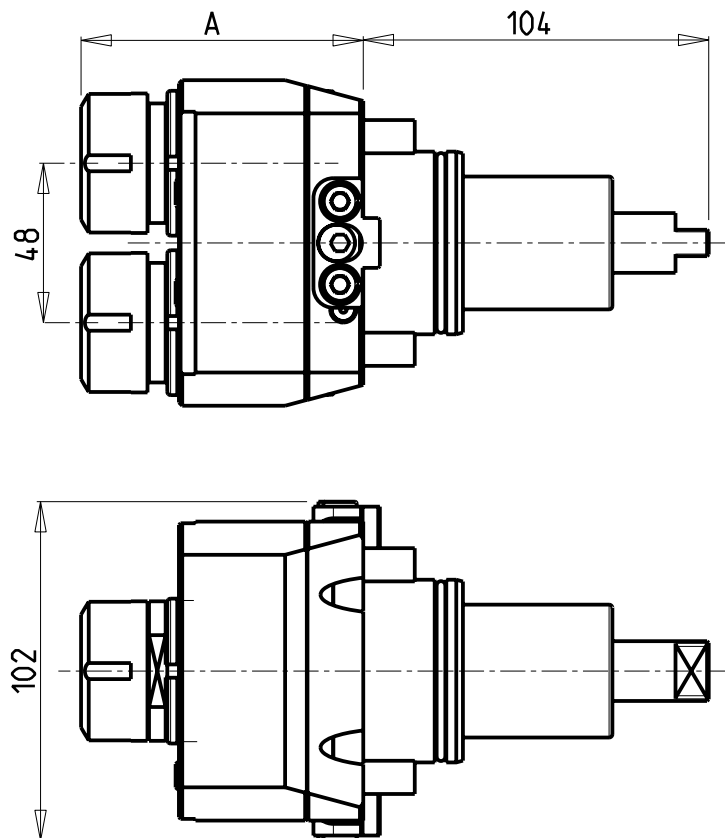

Cod. MT	Mandrino Spindle Spindel	I	RPM	Coppia Max Max Torque Max Drehmoment	Lubrificazione est. Ext. coolant AusSENKuehlung	A	CHIAVI NON INCLUSE Keys not included Schlüssel nicht einbegriffen	
0730016X2	ER16	1:1	6000	30Nm	X	84.5	CHMNER16	CHUB17
0730025X2	ER25	1:1	6000	30Nm	X	85	CHSTER25	MNL0210007

**DOOSAN BMT 55**

MOD: PUMA 230-240M/MS-280LM - PUMA 1500-2000-2500M/MS/Y/SY - PUMA 2100 SERIE - PUMA TT1500-TT1800MS/SY  
PUMA TL2000-2500 (M)

MODULO MOTORIZZATO RADIALE 2 USCITE IN Y  
Radial single side twin head driven tool in Y  
Radial angetriebenes Werkzeug 2 Ausgaenge in Y

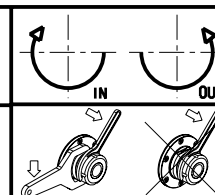

**M.T. srl**

Via Casino Albini 480  
Tel. 0541/956034-957884  
Fax 0541/956341

47842 S. GIOVANNI IN M. (RN)  
e-mail: mtma@mtmarchetti.com  
http://www.mtmarchetti.com

PRODUZIONE MODULI ROTANTI



PAGINA DW0080-2-00

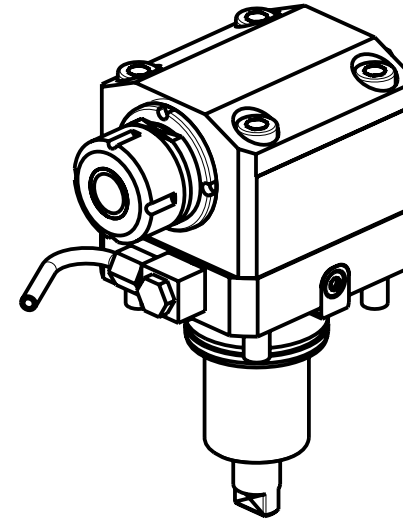
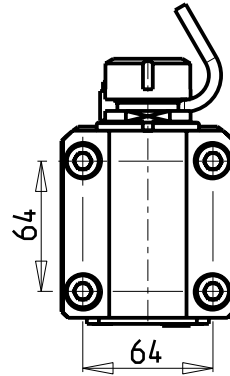
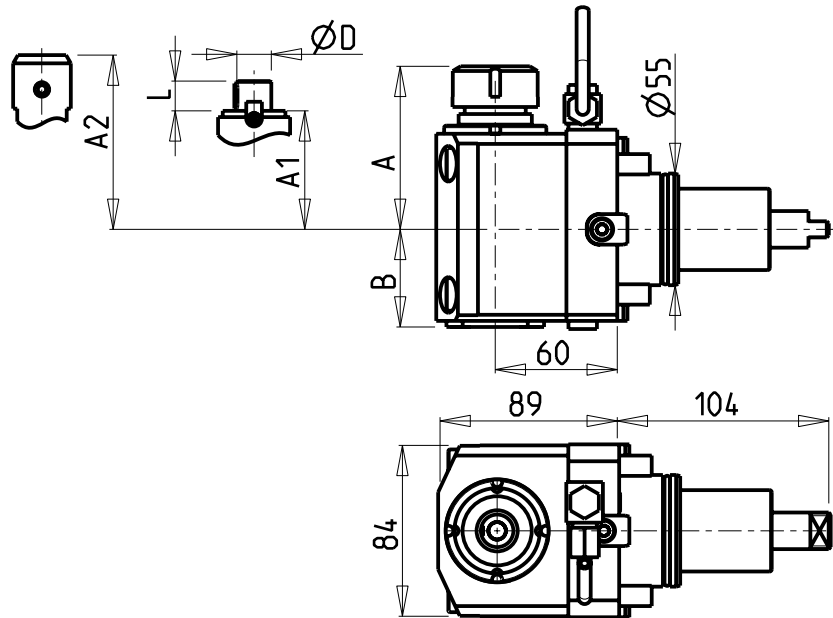

- Chiave inclusa
- Key included
- Schluessel inbegriffen

Cod. MT	Cod. EPPINGER	Mandrino Spindle Spindel	I	RPM	Coppia Max Max Torque Max Drehmoment	Reversibile lato mandrino/contromandrino Reversible sub/main spindle side Umkehrbare Spindel-seite/ Gegenspindel-seite	Lubr.interna Coolant through Innenkuehlung	Lubr. esterna Ext. coolant Ausenkuehlung	A	A1	A2	B	D	L	CHIAVI NON INCLUDE Keys not included Schluessel nicht einbegriffen
0310825	7.070.680	ER25	1:1	6000	50Nm	X		X	80.16	-	-	48	-	-	CHSTER25 CHUB36 o 0100000
0311025	-	ER25	1:1	6000	50Nm	X	P=70bar	X	80.66	-	-	71.5	-	-	CHSTER25 CHUB36 o 0100000
0311432	-	ER32	1:1	6000	50Nm	X		X	97.66	-	-	48	-	-	CHSTER32 CHUB36 o 0100000
0311032	-	ER32	1:1	6000	50Nm	X	P=70bar	X	98.16	-	-	71.5	-	-	CHSTER32 CHUB36 o 0100000
0310022	-	WELDON 20	1:1	6000	50Nm	X		X	-	-	100	48	-	-	
0311617	-	Ø16x17	1:1	6000	50Nm	X		X	-	61	-	48	16	17	CH_VTCROCE_M08 CHUB36 o 0100000
0312219	-	Ø22x19	1:1	6000	50Nm	X		X	-	62	-	48	22	19	CH_VTCROCE_M10 CHUB36 o 0100000
0312240	-	Ø22x40	1:1	6000	50Nm	X		X	-	62	-	48	22	40	CH_VTCROCE_M10 CHUB36 o 0100000
0312721	-	Ø27x21	1:1	6000	50Nm	X		X	-	64	-	48	27	21	CH_VTCROCE_M12 CHUB36 o 0100000
0312733	-	Ø27x33	1:1	6000	50Nm	X		X	-	61	-	48	27	33	CH_VTCROCE_M12 CHUB36 o 0100000
0312750	-	Ø27x50	1:1	6000	50Nm	X		X	-	62.5	-	48	27	50	CH_VTCROCE_M12 CHUB36 o 0100000

## DOOSAN BMT 55

MOD: PUMA 230-240M/MS-280LM - PUMA 1500-2000-2500M/MS/Y/SY - LINX 300 M - PUMA 2100 SERIE  
PUMA TT1500-TT1800MS/SY - TL2000-2500 (M) - PUMA GT2100 M

MODULO MOTORIZZATO ASSIALE H=60mm

Axial driven tool H=60mm

Axial angetriebenes Werkzeug H=60mm

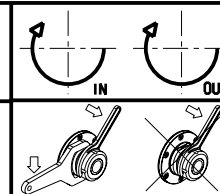

## M.T. srl

Via Casino Albini 480  
Tel. 0541/956034-957884  
Fax 0541/956341  
47842 S. GIOVANNI IN M. (RN)  
e-mail: mtma@mtmarchetti.com  
http://www.mtmarchetti.com

PRODUZIONE MODULI ROTANTI



PAGINA DW 0150-2-10

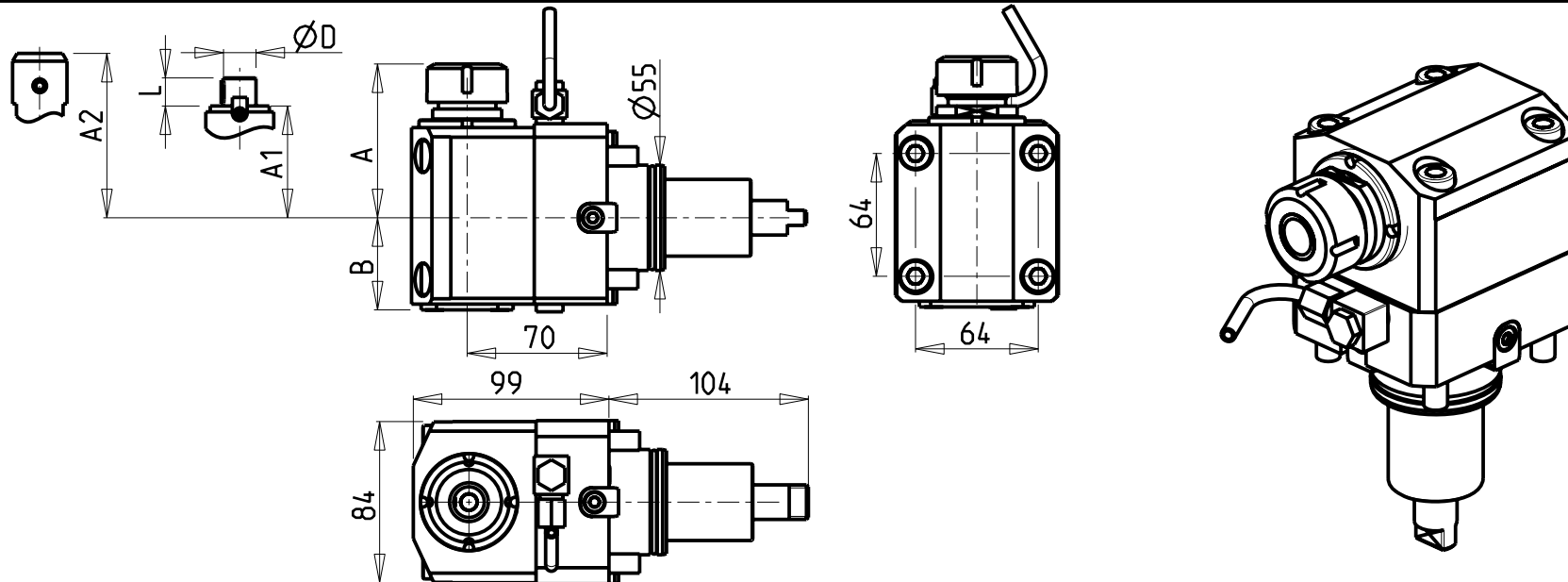

- Chiave inclusa
- Key included
- Schlüssel inbegriffen

Cod. MT	Mandrino Spindle Spindel	I	RPM	Coppia Max Max Torque Max Drehmoment	Reversibile lato mandrino/contromandrino Reversible sub/main spindle side Umkehrbare Spindel-seite/ Gegenspindel-seite	Lubr.interna Coolant through Innenkuehlung	Lubr. esterna Ext. coolant Aussenkuehlung	A	A1	A2	B	D	L	CHIAVI NON INCLUSE Keys not included Schluessel nicht einbegriffen
DW 00240125	ER25	1:1	6000	50Nm	X		X	80.16	-	-	48	-	-	CHSTER25 CHUB36 o 0100000
DW 00240225	ER25	1:1	6000	50Nm	X	P=70bar	X	80.66	-	-	71.5	-	-	CHSTER25 CHUB36 o 0100000
DW 00240132	ER32	1:1	6000	50Nm	X		X	97.66	-	-	48	-	-	CHSTER32 CHUB36 o 0100000
DW 00240232	ER32	1:1	6000	50Nm	X	P=70bar	X	98.16	-	-	71.5	-	-	CHSTER32 CHUB36 o 0100000
DW 00240022	WELDON 20	1:1	6000	50Nm	X		X	-	-	100	48	-	-	
DW 00241617	Ø16x17	1:1	6000	50Nm	X		X	-	61	-	48	16	17	CH_VTCROCE_M08 • CHUB36 o 0100000
DW 00242219	Ø22x19	1:1	6000	50Nm	X		X	-	62	-	48	22	19	CH_VTCROCE_M10 • CHUB36 o 0100000
DW 00242240	Ø22x40	1:1	6000	50Nm	X		X	-	62	-	48	22	40	CH_VTCROCE_M10 • CHUB36 o 0100000
DW 00242721	Ø27x21	1:1	6000	50Nm	X		X	-	64	-	48	27	21	CH_VTCROCE_M12 • CHUB36 o 0100000
DW 00242733	Ø27x33	1:1	6000	50Nm	X		X	-	61	-	48	27	33	CH_VTCROCE_M12 • CHUB36 o 0100000
DW 00242750	Ø27x50	1:1	6000	50Nm	X		X	-	62.5	-	48	27	50	CH_VTCROCE_M12 • CHUB36 o 0100000

## DOOSAN BMT 55

MOD: PUMA 230-240M/MS-280LM - PUMA 1500-2000-2500M/MS/Y/SY - LINX 300 M - PUMA 2100 SERIE  
PUMA TT1500-TT1800MS/SY - TL2000-2500 (M) - PUMA GT2100 M

MODULO MOTORIZZATO ASSIALE H=70mm

Axial driven tool H=70mm

Axial angetriebenes Werkzeug H=70mm

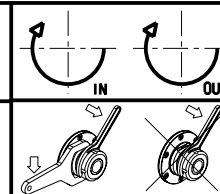

**M.T. srl**

Via Casino Albini 480  
Tel. 0541/956034-957884

Fax 0541/956341

47842 S. GIOVANNI IN M. (RN)

e-mail: mtma@mtmarchetti.com

http://www.mtmarchetti.com

PRODUZIONE MODULI ROTANTI



PAGINA DW 0150-2-20

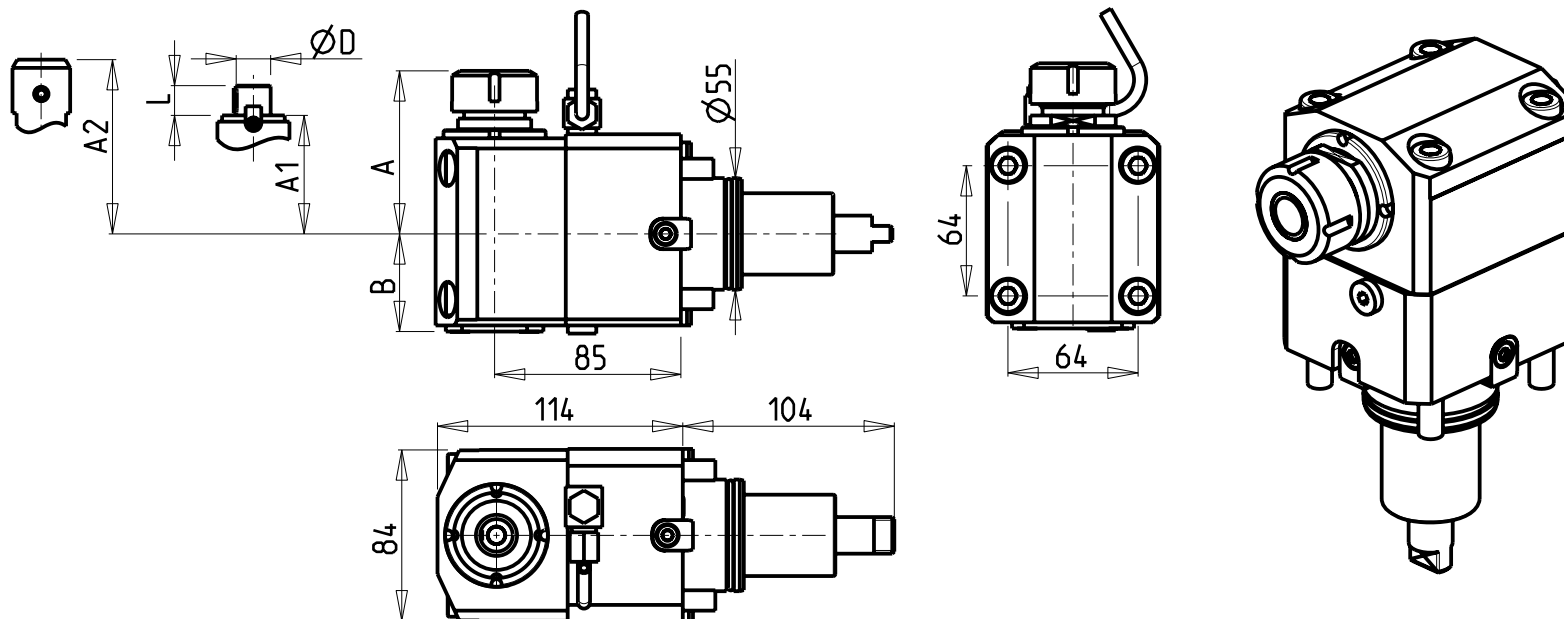

ATTENZIONE - ATTENTION - ACHTUNG

- VERIFICARE LE MISURE DI INGOMBRO PER POSSIBILE INTERFERENZA SU ALCUNI MODELLI DI MACCHINE
- Please check the overall sizes for possible interferences on some machine models
- Bitte überprüfen sie das ausmass um mögliche interferenzen auf einigen maschinen modellen zu vermeiden

- Chiave inclusa
- Key included
- Schluessel inbegriffen

Cod. MT	Mandrino Spindle Spindel	I	RPM	Coppia Max Max Torque Max Drehmoment	Reversibile lato mandrino/contromandrino Reversible sub/main spindle side Umkehrbare Spindelsete/Gegenspindelsete	Lubr.interna Coolant through Innenkuehlung	Lubr. esterna Ext. coolant Aussenkuehlung	A	A1	A2	B	D	L	CHIAVI NON INCLUSE Keys not included Schluessel nicht einbegriffen	
DW 00020125	ER25	1:1	6000	50Nm	X		X	82.36	-	-	48	-	-	CHSTER25	CHUB36 o 010000
DW 00020225	ER25	1:1	6000	50Nm	X	P=70bar	X	81.76	-	-	71.5	-	-	CHSTER25	CHUB36 o 010000
DW 00020132	ER32	1:1	6000	50Nm	X		X	98.16	-	-	48	-	-	CHSTER32	CHUB36 o 010000
DW 00020232	ER32	1:1	6000	50Nm	X	P=70bar	X	97.56	-	-	71.5	-	-	CHSTER32	CHUB36 o 010000
DW 00020022	WELDON 20	1:1	6000	50Nm	X		X	-	-	100	48	-	-		
DW 00021617	Ø16x17	1:1	6000	50Nm	X		X	-	61	-	48	16	17	CH_VTCROCE_M08	CHUB36 o 010000
DW 00022219	Ø22x19	1:1	6000	50Nm	X		X	-	62	-	48	22	19	CH_VTCROCE_M10	CHUB36 o 010000
DW 00022240	Ø22x40	1:1	6000	50Nm	X		X	-	62	-	48	22	40	CH_VTCROCE_M10	CHUB36 o 010000
DW 00022721	Ø27x21	1:1	6000	50Nm	X		X	-	64	-	48	27	21	CH_VTCROCE_M12	CHUB36 o 010000
DW 00022733	Ø27x33	1:1	6000	50Nm	X		X	-	61	-	48	27	33	CH_VTCROCE_M12	CHUB36 o 010000
DW 00022750	Ø27x50	1:1	6000	50Nm	X		X	-	62.5	-	48	27	50	CH_VTCROCE_M12	CHUB36 o 010000

DOOSAN BMT 55

MOD: PUMA 230-240M/MS-280LM - PUMA 1500-2000-2500M/MS/Y/SY - LINX 300 M - PUMA 2100 SERIE  
PUMA TT1500-TT1800MS/SY - PUMA TL2000-2500 (M) - MX1600/2100TS - PUMA GT2100 M

MODULO MOTORIZZATO ASSIALE H=85mm

Axial driven tool H=85mm

Axial angetriebenes Werkzeug H=85mm

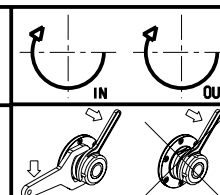

M.T. srl

Via Casino Albini 480  
Tel. 0541/956034-957884  
Fax 0541/956341  
47842 S. GIOVANNI IN M. (RN)  
e-mail: mtma@mtmarchetti.com  
http://www.mtmarchetti.com

PRODUZIONE MODULI ROTANTI



PAGINA DW 0150-2-30

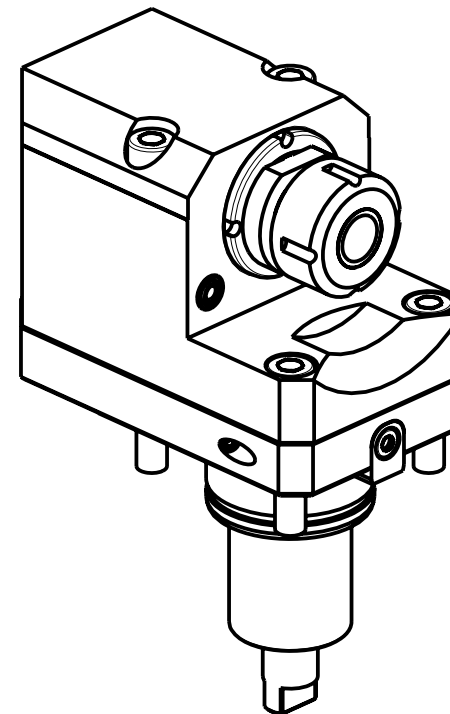
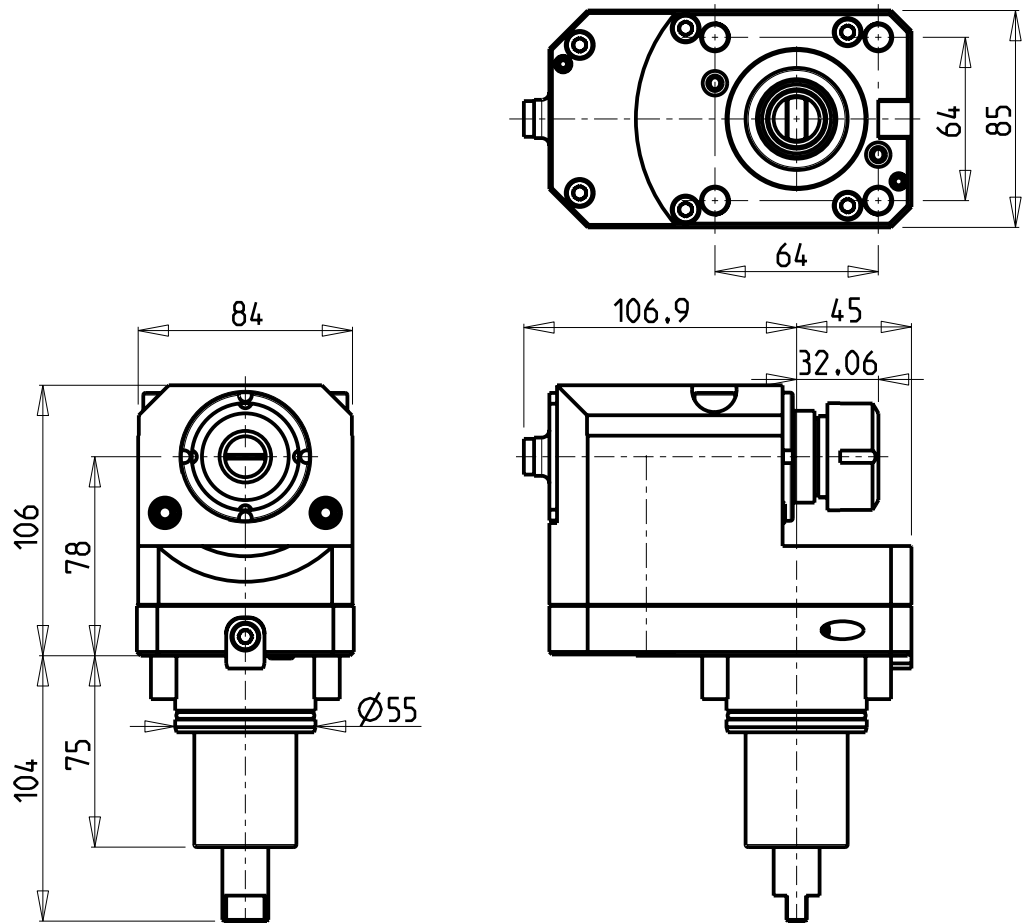

Cod. MT	Mandrino Spindle Spindel	I	RPM	Coppia Max Max Torque Max Drehmoment	Reversibile lato mandrino/contromandrino Reversible sub/main spindle side Umkehrbare Spindel-seite/ Gegenspindel-seite	Lubrificazione est. Ext. coolant Aussenkuehlung	CHIAVI NON INCLUSE Keys not included Schlüssel nicht einbegriffen	
0630025	ER25	1:1	6000	50Nm	X	X	CHSTER25	CHUB36

## DOOSAN BMT 55

MOD: PUMA 230-240M/MS-280LM - PUMA 1500-2000-2500M/MS/Y/SY - LINX 300 M - PUMA 2100 SERIE  
PUMA TT1500-TT1800MS/SY - TL2000-2500 (M) - PUMA GT2100 M

MODULO MOTORIZZATO ASSIALE ARRETRATO

Axial rear-set driven tool

Axial angetriebenes Werkzeug zurueckversetzt

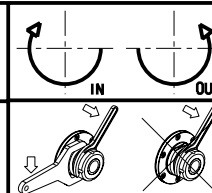

## M.T. srl

Via Casino Albini 480  
Tel. 0541/956034-957884  
Fax 0541/956341

47842 S. GIOVANNI IN M. (RN)  
e-mail: mtma@mtmarchetti.com  
http://www.mtmarchetti.com

PRODUZIONE MODULI ROTANTI



PAGINA DW 0180-2-10



## ATTENZIONE - ATTENTION - ACHTUNG

- Su macchine MX1600ST e MX2100ST solo i motorizzati H=85 arrivano a centro mandrino
- The driven tools with H=85 reach the spindle axis only on lathes MX1600ST and MX2100ST
- Auf MX1600ST und MX2100ST Maschinen erreichen nur die angetriebenen Werkzeugen mit H=85 das Zentrum der Spindel

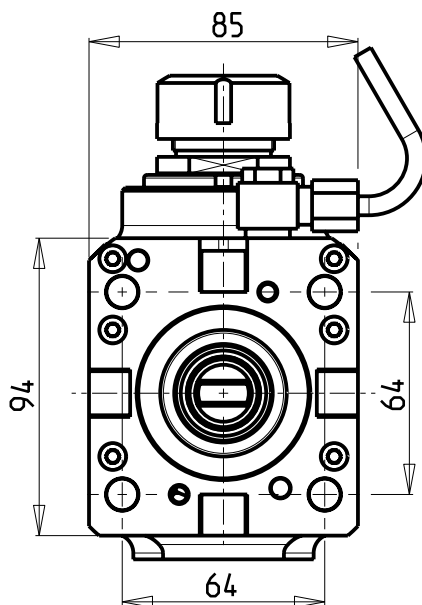
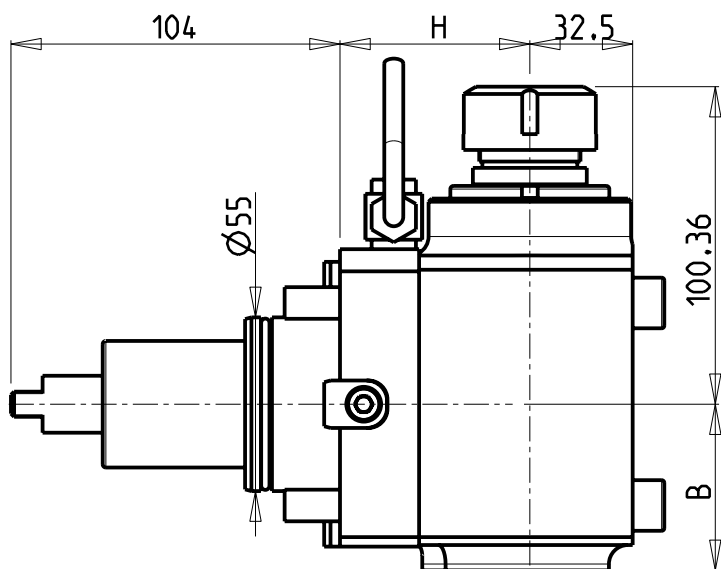

### ATTENZIONE - ATTENTION - ACHTUNG

- VERIFICARE LE MISURE DI INGOMBRO PER POSSIBILE INTERFERENZA SU ALCUNI MODELLI DI MACCHINE
- Please check the overall sizes for possible interferences on some machine models
- Bitte überprüfen sie das ausmass um mögliche interferenzen auf einigen maschinen modellen zu vermeiden

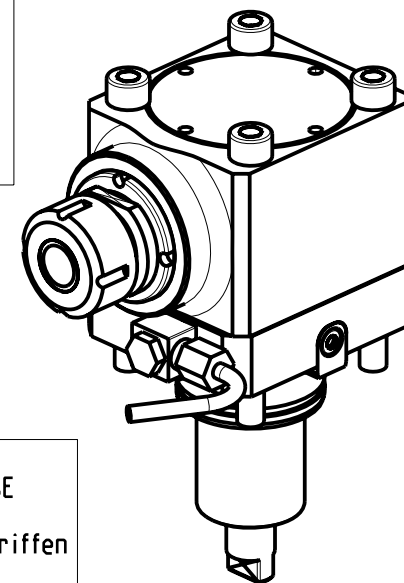

Cod. MT	Mandrino Spindel Spindel	I	RPM	Coppia Max Max Torque Max Drehmoment	Reversibile lato mandrino/controlmandrino Reversible sub/main spindle side Umkehrbare Spindel-seite/Gegenspindel-seite	Lubrificazione int. Coolant through Innenkuehlung	Lubrificazione est. Ext. coolant Aussenkuehlung	H	B	CHIAVI NON INCLUSE Keys not included Schluessel nicht einbegriffen	
0891225	ER25	1:2	12000	30Nm	X		X	60	52.5	CHSTER25	CHUB36
0891325	ER25	1:2	12000	30Nm	X	P=70bar	X	60	79	CHSTER25	CHUB36
0893625	ER25	1:2	12000	30Nm	X		X	70	52.5	CHSTER25	CHUB36
0893725	ER25	1:2	12000	30Nm	X	P=70bar	X	70	79	CHSTER25	CHUB36
0892425	ER25	1:2	12000	30Nm	X		X	85	52.5	CHSTER25	CHUB36
0892525	ER25	1:2	12000	30Nm	X	P=70bar	X	85	79	CHSTER25	CHUB36

## DOOSAN BMT 55

MOD: PUMA 230-240M/MS-280LM - PUMA 1500-2000-2500M/MS/Y/SY - LINX 300 M - PUMA 2100 SERIE  
PUMA TT1500-TT1800MS/SY - PUMA TL2000-2500 (M) - MX1600/2100TS - PUMA GT2100 M

MODULO MOTORIZZATO ASSIALE MOLTIPLICATO I=1:2

Axial geared-up I=1:2 driven tool

Axial angetriebenes Werkzeug uebersetzt I=1:2

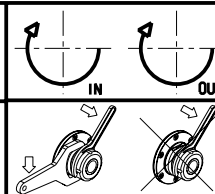

## M.T. srl

Via Casino Albini 480  
Tel. 0541/956034-957884

Fax 0541/956341

47842 S. GIOVANNI IN M. (RN)

e-mail: mtma@mtmarchetti.com

http://www.mtmarchetti.com

PRODUZIONE MODULI ROTANTI



PAGINA DW 0200-2-10

**ATTENZIONE - ATTENTION - ACHTUNG**

- VERIFICARE LE MISURE DI INGOMBRO PER POSSIBILE INTERFERENZA SU ALCUNI MODELLI DI MACCHINE
- Please check the overall sizes for possible interferences on some machine models
- Bitte überprüfen sie das ausmass um mögliche interferenzen auf einigen maschinen modellen zu vermeiden

**ATTENZIONE - ATTENTION - ACHTUNG**

- Su macchine MX1600ST e MX2100ST solo i motorizzati H=85 arrivano a centro mandrino
- The driven tools with H=85 reach the spindle axis only on lathes MX1600ST and MX2100ST
- Auf MX1600ST und MX2100ST Maschinen erreichen nur die angetriebenen Werkzeugen mit H=85 das Zentrum der Spindel

**ATTENZIONE - ATTENTION - ACHTUNG**

- PRIMA DI UTILIZZARE IL MOTORIZZATO CONSULTARE LE ISTRUZIONI ALLEGATE!
- BEFORE USING THE DRIVEN TOOL, PLEASE CHECK THE ENCLOSED INSTRUCTION SHEET!
- VOR DER BENUTZUNG DES ANGETRIEBENEN WERKZEUGES, DIE BEILIEGENDEN INSTRUKTIONEN DURCHLESEN!

**ATTENZIONE - ATTENTION - ACHTUNG**

- Per lo smontaggio degli utensili utilizzare sempre la chiave di contrasto come indicato nel manuale d'uso.
- For disassembly of the tools use always the contrast key as mentioned in the user instructions.
- Fuer das Abmontieren der Werkzeuge immer den Gegenschlüssel benutzen wie in der Bedienungsanleitung erwaeht.

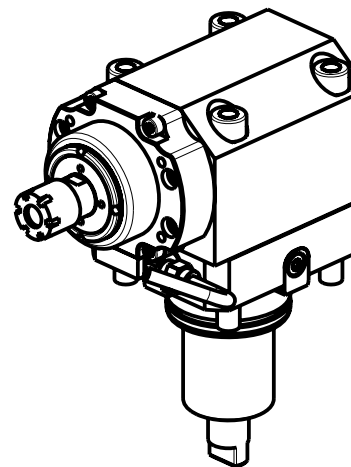
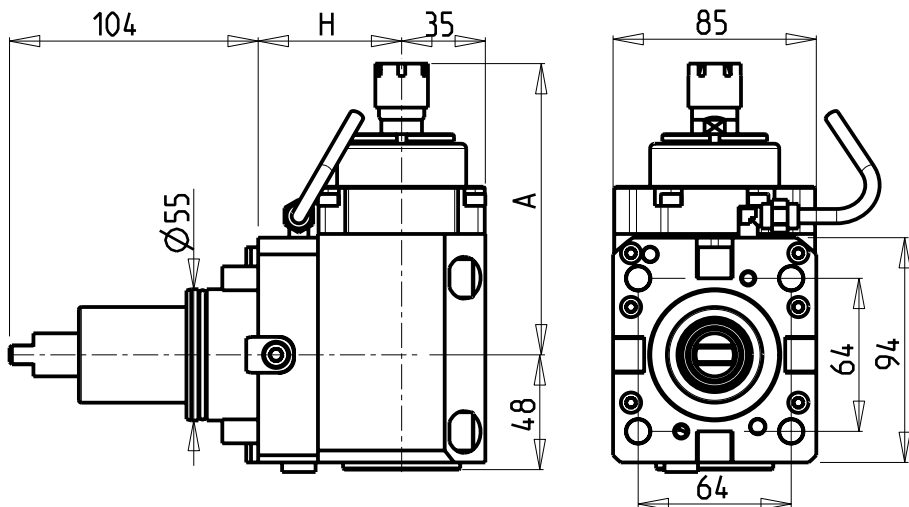

Cod. MT	Mandrino Spindle Spindel	I	RPM MAX	Coppia Max Max Torque Max Drehmoment	Reversibile lato mandrino/contromandrino Reversible sub/main spindle side Umkehrbare Spindel-seite/ Gegenspindel-seite	Lubrificazione int. Coolant through Innenkuehlung	Lubrificazione est. Ext. coolant Aussenkuehlung	A	H	CHIAVI INCLUSE Keys included Schluessel einbegriffen	
DW 00190116	ER16	1:5.625	22500	6Nm	X		X	121.8	60	CHMNER16	CHUB17
DW 00190111	ER11	1:5.625	22500	6Nm	X	P=30bar		134	60	CHMNER11	CHUB11
DW 00190316	ER16	1:5.625	22500	6Nm	X		X	121.8	70	CHMNER16	CHUB17
DW 00190311	ER11	1:5.625	22500	6Nm	X	P=30bar		134	70	CHMNER11	CHUB11
DW 00190216	ER16	1:5.625	22500	6Nm	X		X	121.8	85	CHMNER16	CHUB17
DW 00190211	ER11	1:5.625	22500	6Nm	X	P=30bar		134	85	CHMNER11	CHUB11

**DOOSAN BMT 55**

MOD: PUMA 230-240M/MS-280LM - PUMA 1500-2000-2500M/MS/Y/SY - LINX 300 M - PUMA 2100 SERIE  
PUMA TT1500-TT1800MS/SY - PUMA TL2000-2500 (M) - MX1600/2100TS - PUMA GT2100 M

MODULO MOTORIZZATO ASSIALE MOLTIPLICATO I=1:5.625

Axial geared-up I=1:5.625 driven tool

Axial angetriebenes Werkzeug uebersetzt I=1:5.625

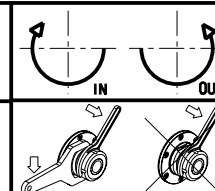

**M.T. srl**

Via Casino Albini 480  
Tel. 0541/956034-957884  
Fax 0541/956341  
47842 S. GIOVANNI IN M. (RN)  
e-mail: mtma@mtmarchetti.com  
http://www.mtmarchetti.com

PRODUZIONE MODULI ROTANTI



PAGINA DW 0210-2-10

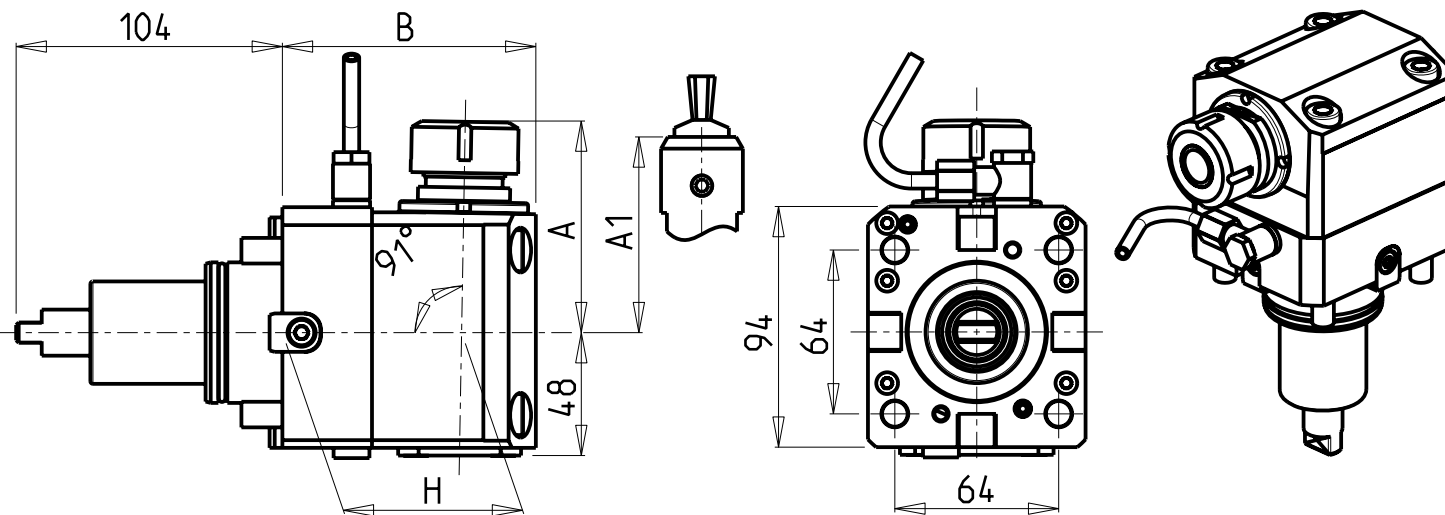

### ATTENZIONE - ATTENTION - ACHTUNG

- Su macchine MX1600ST e MX2100ST solo i motorizzati H=85 arrivano a centro mandrino
- The driven tools with H=85 reach the spindle axis only on lathes MX1600ST and MX2100ST
- Auf MX1600ST und MX2100ST Maschinen erreichen nur die angetriebenen Werkzeugen mit H=85 das Zentrum der Spindel

### ATTENZIONE - ATTENTION - ACHTUNG

- VERIFICARE LE MISURE DI INGOMBRO PER POSSIBILE INTERFERENZA SU ALCUNI MODELLI DI MACCHINE
- Please check the overall sizes for possible interferences on some machine models
- Bitte überprüfen sie das ausmass um mögliche interferenzen auf einigen maschinen modellen zu vermeiden

Cod. MT	Mandrino Spindle Spindel	I	RPM	Coppia Max Max Torque Max Drehmoment	Reversibile lato mandrino/contromandrino Reversible sub/main spindle side Umkehrbare Spindel-seite/ Gegenspindel-seite	Lubrificazione est. Ext. coolant Aussenkuehlung	A	A1	B	H	CHIAVI NON INCLUSE Keys not included Schluessel nicht einbegriffen	
0319125	ER25	1:1	6000	50Nm	X	X	82.35	-	89	60	CHSTER25	CHUB36 o 0100000
0319108	WELDON 8	1:1	6000	50Nm	X	X	-	76.5	89	60		
0319110	WELDON 10	1:1	6000	50Nm	X	X	-	76.5	89	60		
0319112	WELDON 12	1:1	6000	50Nm	X	X	-	76.5	89	60		
0319116	WELDON 16	1:1	6000	50Nm	X	X	-	73.5	89	60		
DW 00249125	ER25	1:1	6000	50Nm	X	X	82.35	-	99	70	CHSTER25	CHUB36 o 0100000
DW 00249108	WELDON 8	1:1	6000	50Nm	X	X	-	76.5	99	70		
DW 00249110	WELDON 10	1:1	6000	50Nm	X	X	-	76.5	99	70		
DW 00249112	WELDON 12	1:1	6000	50Nm	X	X	-	76.5	99	70		
DW 00249116	WELDON 16	1:1	6000	50Nm	X	X	-	76.5	99	70		
DW 00029125	ER25	1:1	6000	50Nm	X	X	82.35	-	114	85	CHSTER25	CHUB36 o 0100000
DW 00029108	WELDON 8	1:1	6000	50Nm	X	X	-	76.5	114	85		
DW 00029110	WELDON 10	1:1	6000	50Nm	X	X	-	76.5	114	85		
DW 00029112	WELDON 12	1:1	6000	50Nm	X	X	-	76.5	114	85		
DW 00029116	WELDON 16	1:1	6000	50Nm	X	X	-	73.5	114	85		

## DOOSAN BMT 55

MOD: PUMA 230-240M/MS-280LM - PUMA 1500-2000-2500M/MS/Y/SY - LINX 300 M - PUMA 2100 SERIE  
PUMA TT1500-TT1800MS/SY - PUMA TL2000-2500 (M) - MX1600/2100TS - PUMA GT2100 M

MODULO MOTORIZZATO ASSIALE PER POLIGONATURA INTERNA

Axial driven tool for internal polygon-making

Axial angetriebenes Werkzeug fuer interne Facettierung

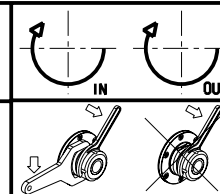

## M.T. srl

Via Casino Albini 480  
Tel. 0541/956034-957884

Fax 0541/956341

47842 S. GIOVANNI IN M. (RN)

e-mail: mtma@mtmarchetti.com

http://www.mtmarchetti.com

PRODUZIONE MODULI ROTANTI



PAGINA DW 0230-2-10

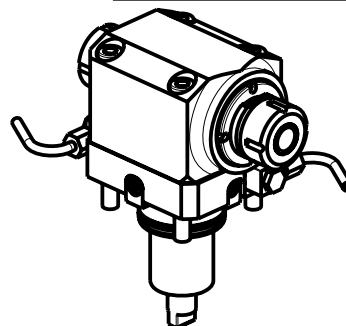
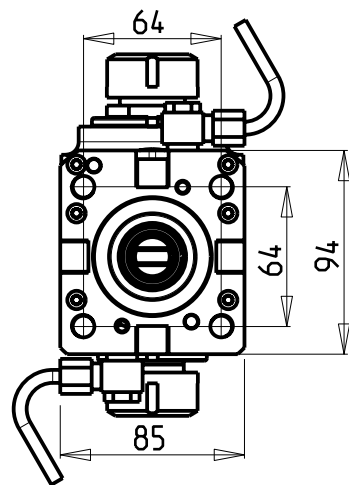
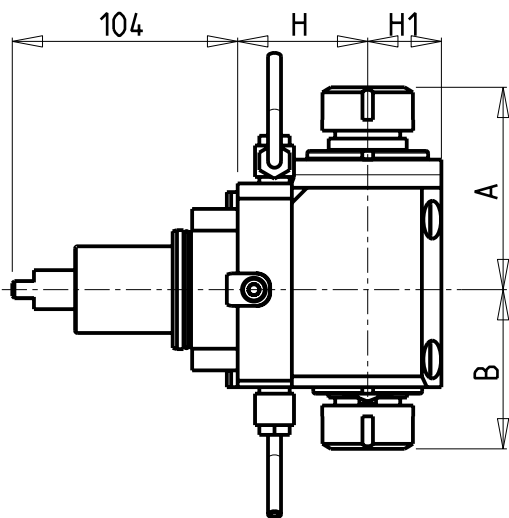

**ATTENZIONE - ATTENTION - ACHTUNG**

- VERIFICARE LE MISURE DI INGOMBRO PER POSSIBILE INTERFERENZA SU ALCUNI MODELLI DI MACCHINE
- Please check the overall sizes for possible interferences on some machine models
- Bitte überprüfen sie das ausmass um mögliche interferenzen auf einigen maschinen modellen zu vermeiden

**ATTENZIONE - ATTENTION - ACHTUNG**

- Su macchine MX1600ST e MX2100ST solo i motorizzati H=85 arrivano a centro mandrino
- The driven tools with H=85 reach the spindle axis only on lathes MX1600ST and MX2100ST
- Auf MX1600ST und MX2100ST Maschinen erreichen nur die angetriebenen Werkzeugen mit H=85 das Zentrum der Spindel

**ATTENZIONE - ATTENTION - ACHTUNG**

- Per lo smontaggio degli utensili utilizzare sempre la chiave di contrasto come indicato nel manuale d'uso.
- For disassembly of the tools use always the contrast key as mentioned in the user instructions.
- Fuer das Abmontieren der Werkzeuge immer den Gegenschlüssel benutzen wie in der Bedienungsanleitung erwahnt.

Cod. MT	Mandrino Spindel	I	RPM	Coppia Max Max Torque Max Drehmoment	Reversibile lato mandrino/contromandrino Reversible sub/main spindle side Umkehrbare Spindel-seite/ Gegenspindel-seite	Lubrificazione est. Ext. coolant Aussenkuehlung	A	B	H	H1	CHIAVI NON INCLUSE Keys not included Schlüssel nicht einbegriffen	
DW 00080132	ER32+ER32	1:1	6000	50Nm	X	X	100.56	78.96	60	34	CHSTER32	CHUB36 o 0100000
DW 00080332	ER32+ER32	1:1	6000	50Nm	X	X	100.56	78.96	70	34	CHSTER32	CHUB36 o 0100000
DW 00080232	ER32+ER32	1:1	6000	50Nm	X	X	100.56	78.96	85	34	CHSTER32	CHUB36 o 0100000
DW 00080125	ER25+ER25	1:1	6000	50Nm	X	X	93.36	73.46	60	34	CHSTER25	CHUB36+CHUB29
DW 00080325	ER25+ER25	1:1	6000	50Nm	X	X	93.36	73.46	70	34	CHSTER25	CHUB36+CHUB29
DW 00080225	ER25+ER25	1:1	6000	50Nm	X	X	93.36	73.46	85	34	CHSTER25	CHUB36+CHUB29
0311625	ER25+ER16	1:1	6000	50Nm	X	X	81.86	66	60	29	CHMNER16+CHSTER25	CHUB36 o 0100000
DW 00242516	ER25+ER16	1:1	6000	50Nm	X	X	81.86	66	70	29	CHMNER16+CHSTER25	CHUB36 o 0100000
DW 00022516	ER25+ER16	1:1	6000	50Nm	X	X	81.86	66	85	29	CHMNER16+CHSTER25	CHUB36 o 0100000
0311616	ER16+ER16	1:1	6000	50Nm	X	X	81.2	66	60	29	CHMNER16	CHUB36 o 0100000
DW 00241616	ER16+ER16	1:1	6000	50Nm	X	X	81.2	66	70	29	CHMNER16	CHUB36 o 0100000
DW 00021616	ER16+ER16	1:1	6000	50Nm	X	X	81.2	66	85	29	CHMNER16	CHUB36 o 0100000

**DOOSAN BMT 55**

MOD: PUMA 230-240M/MS-280LM - PUMA 1500-2000-2500M/MS/Y/SY - LINX300 M - PUMA 2100 SERIE  
PUMA TT1500-TT1800MS/SY - PUMA TL2000-2500 (M) - MX1600/2100TS - PUMA GT2100 M

**MODULO MOTORIZZATO ASSIALE BISPORGENTE**

Axial opposite face twin driven tool

Axial angetriebenes Werkzeug halb vorspringend

**M.T. srl**

Via Casino Albini 480  
Tel. 0541/956034-957884  
Fax 0541/956341  
47842 S. GIOVANNI IN M. (RN)  
e-mail: mtma@mtmarchetti.com  
http://www.mtmarchetti.com

**PRODUZIONE MODULI ROTANTI**



**PAGINA DW 0240-2-10**

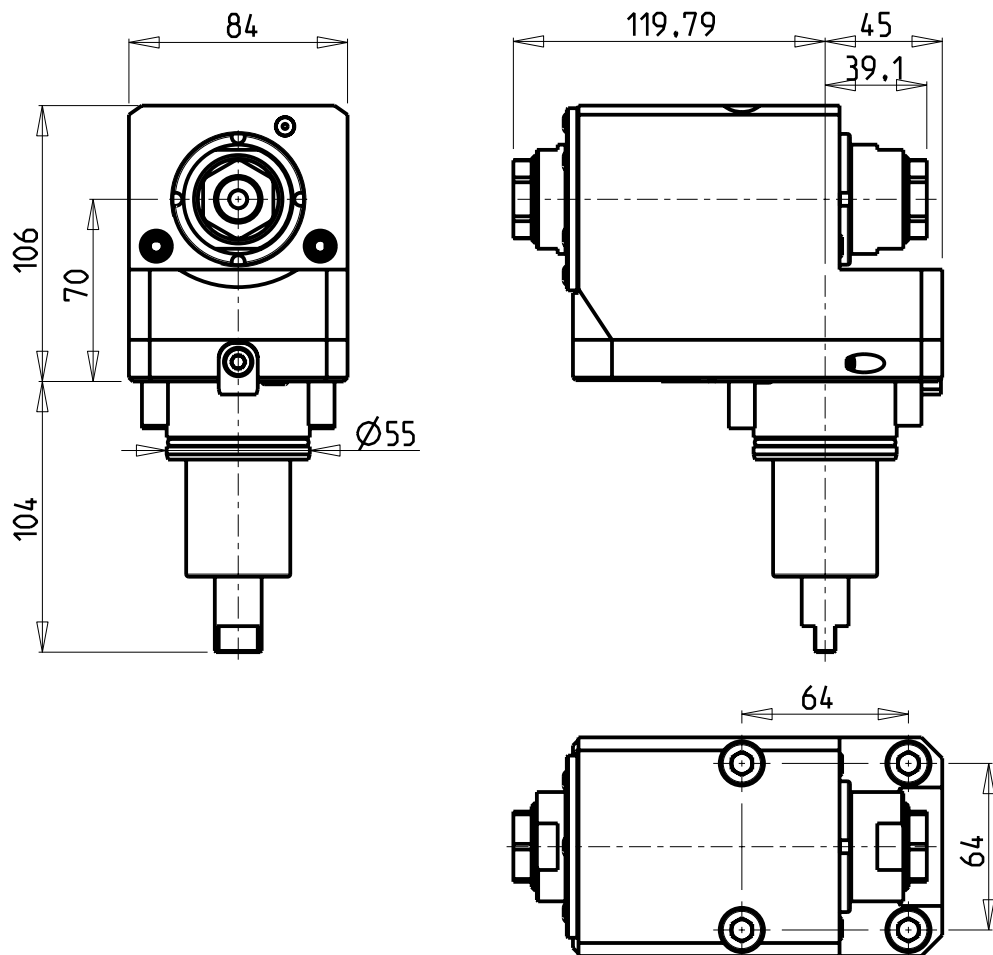

### ATTENZIONE - ATTENTION - ACHTUNG

- Per lo smontaggio degli utensili utilizzare sempre la chiave di contrasto come indicato nel manuale d'uso.
- For disassembly of the tools use always the contrast key as mentioned in the user instructions.
- Fuer das Abmontieren der Werkzeuge immer den Gegenschlüssel benutzen wie in der Bedienungsanleitung erwaeht.

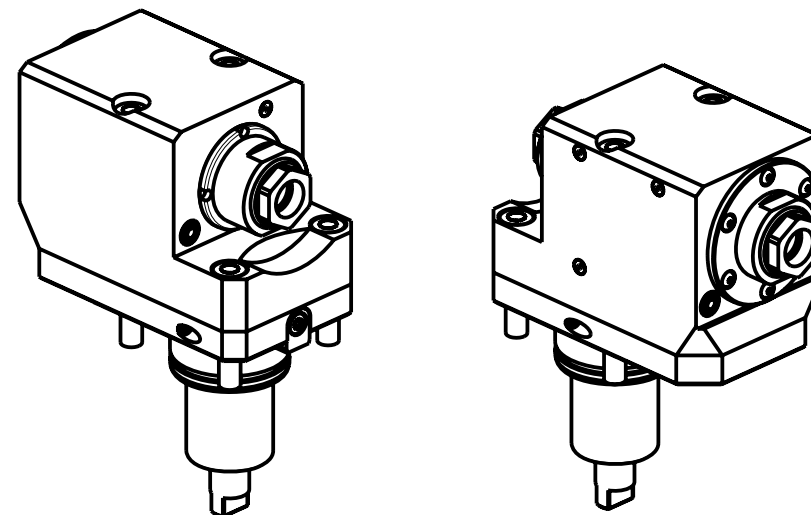

Cod. MT	Mandrino Spindle Spindel	I	RPM	Coppia Max Max Torque Max Drehmoment	Reversibile lato mandrino/contromandrino Reversible sub/main spindle side Umkehrbare Spindelseite/ Gegenspindelseite	Lubrificazione est. Ext. coolant Aussenkuehlung	CHIAVI NON INCLUSE Keys not included Schluessel nicht inbegriffen	
							CHUB27	CHUB38
0632525	ERA25+ERA25	1:1	6000	50Nm	X	X	CHUB27	CHUB38

## DOOSAN BMT 55

MOD: PUMA 230-240M/MS-280LM - PUMA 1500-2000-2500M/MS/Y/SY - LINX 300 M - PUMA 2100 SERIE  
PUMA TT1500-TT1800MS/SY - TL2000-2500 (M)

MODULO MOTORIZZATO ASSIALE ARRETRATO BISPORGENTE

Axial opposite face rear-set driven tool

Axial angetriebenes Werkzeug zurueckversetzt halb vorspringend

### M.T. srl

Via Casino Albini 480  
Tel. 0541/956034-957884  
Fax 0541/956341  
47842 S. GIOVANNI IN M. (RN)  
e-mail: mtma@mtmarchetti.com  
http://www.mtmarchetti.com

PRODUZIONE MODULI ROTANTI



PAGINA DW 0243-2-10

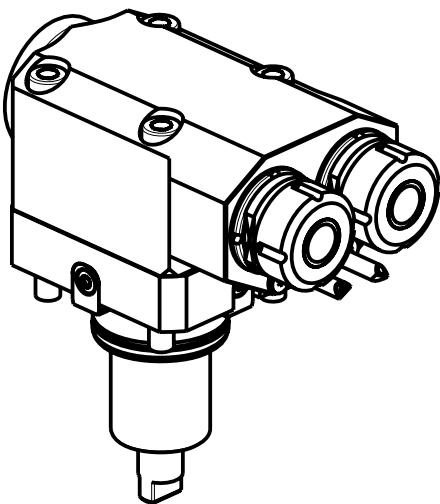
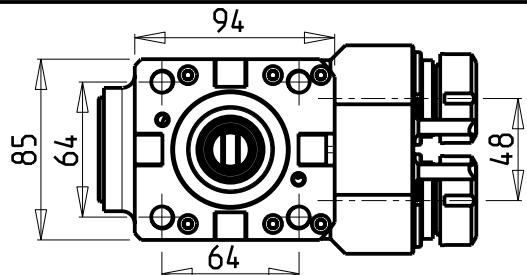

### ATTENZIONE - ATTENTION - ACHTUNG

- Su macchine MX1600ST e MX2100ST solo i motorizzati H=85 arrivano a centro mandrino
- The driven tools with H=85 reach the spindle axis only on lathes MX1600ST and MX2100ST
- Auf MX1600ST und MX2100ST Maschinen erreichen nur die angetriebenen Werkzeugen mit H=85 das Zentrum der Spindel

### ATTENZIONE - ATTENTION - ACHTUNG

- Per lo smontaggio degli utensili utilizzare sempre la chiave di contrasto come indicato nel manuale d'uso.
- For disassembly of the tools use always the contrast key as mentioned in the user instructions.
- Fuer das Abmontieren der Werkzeuge immer den Gegenschlüssel benutzen wie in der Bedienungsanleitung erwäehnt.

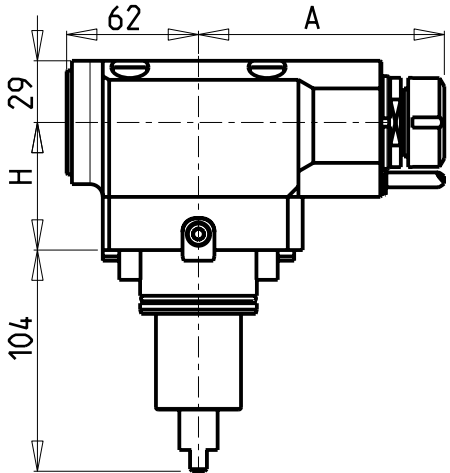
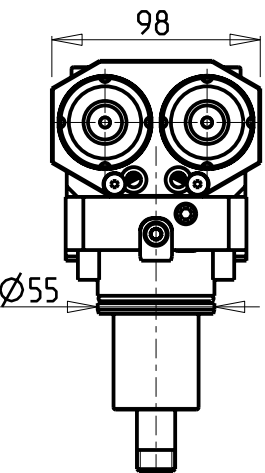

Cod. MT	Mandrino Spindle Spindel	I	RPM	Coppia Max Max Torque Max Drehmoment	Reversibile lato mandrino/contromandrino Reversible sub/main spindle side Umkehrbare Spindel-seite/ Gegenspindel-seite	Lubrificazione est. Ext. coolant Aussenkuehlung	A	H	CHIAVI NON INCLUDE Keys not included Schlüssel nicht einbegriffen	
DW 00100216	ER16	1:1	6000	30Nm	X	X	115.15	60	CHMNER16	CHUB17
DW 00100225	ER25	1:1	6000	30Nm	X	X	115.61	60	CHSTER25	MNL0210007
DW 00102216	ER16	1:1	6000	30Nm	X	X	115.15	70	CHMNER16	CHUB17
DW 00102225	ER25	1:1	6000	30Nm	X	X	115.61	70	CHSTER25	MNL0210007
DW 00101216	ER16	1:1	6000	30Nm	X	X	115.15	85	CHMNER16	CHUB17
DW 00101225	ER25	1:1	6000	30Nm	X	X	115.61	85	CHSTER25	MNL0210007

## DOOSAN BMT 55

MOD: PUMA 230-240M/MS-280LM - PUMA 1500-2000-2500M/MS/Y/SY - PUMA 2100 SERIE - PUMA TT1500-TT1800MS/SY  
PUMA TL2000-2500 (M)

MODULO MOTORIZZATO ASSIALE 2 USCITE IN Y

Axial single side twin head driven tool in Y

Axial angetriebenes Werkzeug 2 Ausgaenge in Y

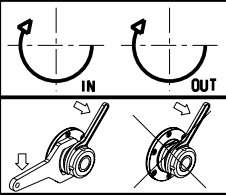

### M.T. srl

Via Casino Albini 480  
Tel. 0541/956034-957884

Fax 0541/956341

47842 S. GIOVANNI IN M. (RN)

e-mail: mtma@mtmarchetti.com

http://www.mtmarchetti.com

PRODUZIONE MODULI ROTANTI I



PAGINA DW 0260-2-10

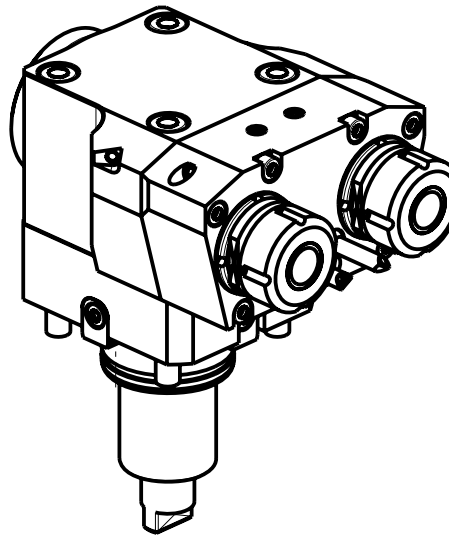
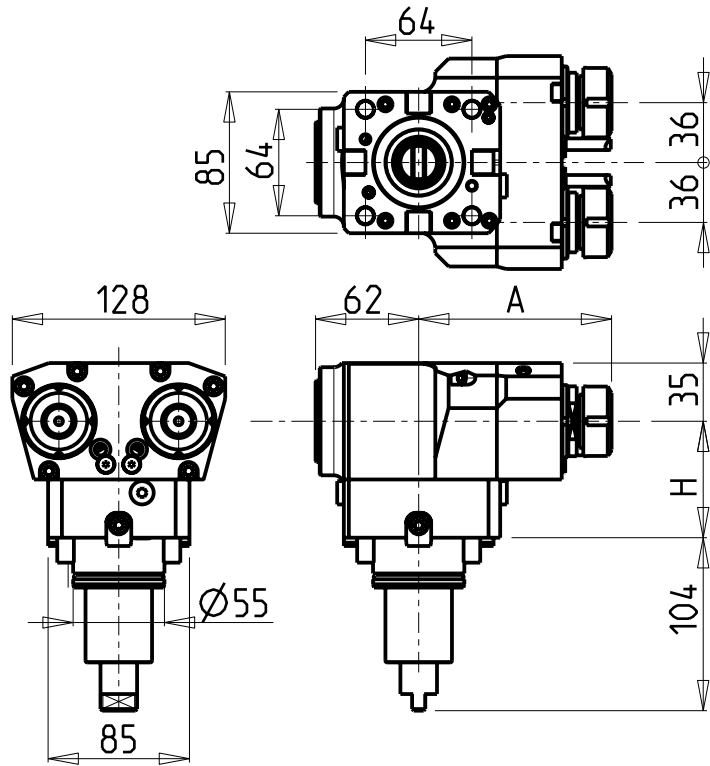

### ATTENZIONE - ATTENTION - ACHTUNG

- Su macchine MX1600ST e MX2100ST solo i motorizzati H=85 arrivano a centro mandrino
- The driven tools with H=85 reach the spindle axis only on lathes MX1600ST and MX2100ST
- Auf MX1600ST und MX2100ST Maschinen erreichen nur die angetriebenen Werkzeugen mit H=85 das Zentrum der Spindel

### ATTENZIONE - ATTENTION - ACHTUNG

- Per lo smontaggio degli utensili utilizzare sempre la chiave di contrasto come indicato nel manuale d'uso.
- For disassembly of the tools use always the contrast key as mentioned in the user instructions.
- Fuer das Abmontieren der Werkzeuge immer den Gegenschlüssel benutzen wie in der Bedienungsanleitung erwäehnt.

Cod. MT	Mandrino Spindle Spindel	I	RPM	Coppia Max Max Torque Max Drehmoment	Reversibile lato mandrino/contromandrino Reversible sub/main spindle side Umkehrbare Spindel-seite/ Gegenspindel-seite	Lubrificazione est. Ext. coolant Aussenkuehlung	A	H	CHIAVI NON INCLUDE Keys not included Schluessel nicht einbegriffen		
DW 00950216	ER16	1:2	12000	20Nm	X	X	115	60	CHMNER16	CHUB17	NEW
DW 00950225	ER25	1:2	12000	20Nm	X	X	115.96	60	CHSTER25	CHUB36	NEW
DW 00951216	ER16	1:2	12000	20Nm	X	X	115	70	CHMNER16	CHUB17	NEW
DW 00951225	ER25	1:2	12000	20Nm	X	X	115.96	70	CHSTER25	CHUB36	NEW
DW 00952216	ER16	1:2	12000	20Nm	X	X	115	85	CHMNER16	CHUB17	NEW
DW 00952225	ER25	1:2	12000	20Nm	X	X	115.96	85	CHSTER25	CHUB36	NEW

## DOOSAN BMT 55

MOD: PUMA 230-240M/MS-280LM - PUMA 1500-2000-2500M/MS/Y/SY - PUMA 2100 SERIE - PUMA TT1500-TT1800MS/SY  
PUMA TL2000-2500 (M)

MODULO MOTORIZZATO ASSIALE 2 USCITE IN Y MOLTIPLICATO I=1:2

Axial geared-up I=1:2 single side twin head driven tool in Y

Axial angetriebenes Werkzeug 2 Ausgaenge in Y uebersetzt I=1:2

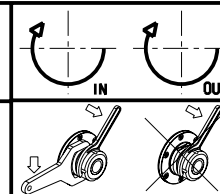

### M.T. srl

Via Casino Albini 480  
Tel. 0541/956034-957884

Fax 0541/956341

47842 S. GIOVANNI IN M. (RN)

e-mail: mtma@mtmarchetti.com

http://www.mtmarchetti.com

PRODUZIONE MODULI ROTANTI



PAGINA DW 0261-2-10

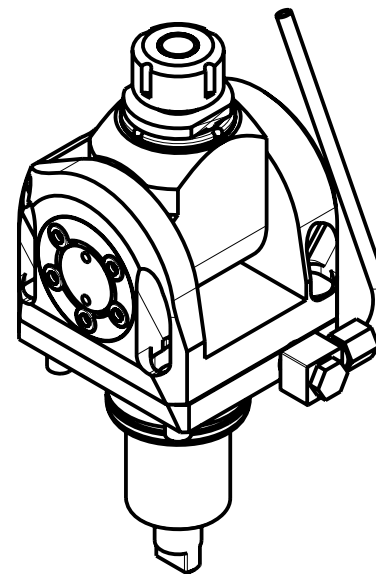
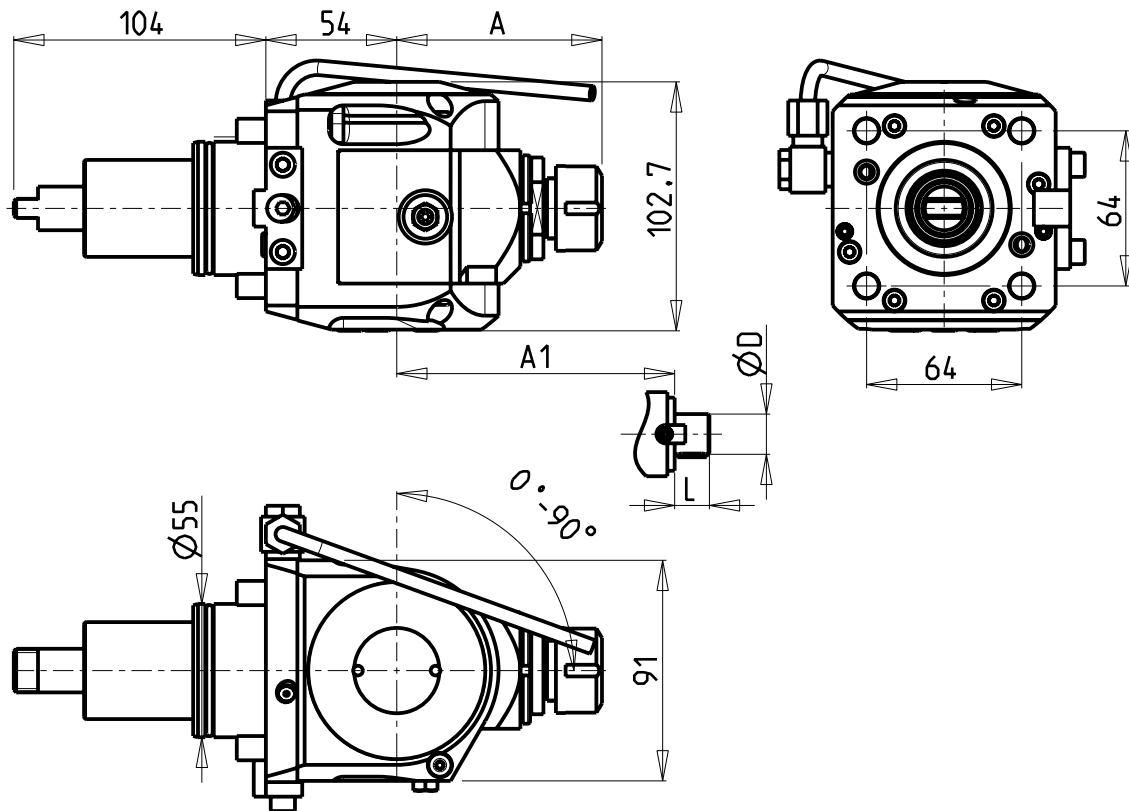

### ATTENZIONE - ATTENTION - ACHTUNG

- VERIFICARE LE MISURE DI INGOMBRO PER POSSIBILE INTERFERENZA SU ALCUNI MODELLI DI MACCHINE
- Please check the overall sizes for possible interferences on some machine models
- Bitte überprüfen sie das ausmass um mögliche interferenzen auf einigen maschinen modellen zu vermeiden

Cod. MT	Mandrino Spindle Spindel	I	RPM	Coppia Max Max Torque Max Drehmoment	Reversibile lato mandrino/contromandrino Reversible sub/main spindle side Umkehrbare Spindelseite/ Gegenspindelseite	Lubrificazione est. Ext. coolant Aussenkuehlung	A	A1	D	L	CHIAVI INCLUSE Keys included Schluessel inbegriffen		
											CHSTER20	CHUB36	CHESL08
0360020	ER20	1:1	6000	40Nm	X	X	84.16	-	-	-	CHSTER20	CHUB36	CHESL08
0360025	ER25	1:1	6000	40Nm	X	X	85.66	-	-	-	CHSTER25	CHUB36	CHESL08
0361617	Ø16x17	1:1	6000	40Nm	X	X	-	65	16	17	CH_VTCROCE_M08	CHUB36	CHESL08
0362219	Ø22x19	1:1	6000	40Nm	X	X	-	66	22	19	CH_VTCROCE_M10	CHUB36	CHESL08
0361905	Ø3/4"x3/4"	1:1	6000	40Nm	X	X	-	65	3/4"	3/4"	CH_VTCROCE_M08	CHUB36	CHESL08

## DOOSAN BMT 55

MOD: PUMA 230-240M/MS-280LM - PUMA 1500-2000-2500M/MS/Y/SY - LINX 300 M - PUMA 2100 SERIE  
PUMA TT1500-TT1800MS/SY - TL2000-2500 (M) - PUMA GT2100 M

MODULO MOTORIZZATO ORIENTABILE 0-90°

0-90° adjustable angle driven tool

Angetriebenes Werkzeug schwenkbar 0-90°

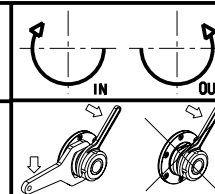

## M.T. srl

Via Casino Albini 480  
Tel. 0541/956034-957884

Fax 0541/956341

47842 S. GIOVANNI IN M. (RN)

e-mail: mtma@mtmarchetti.com

http://www.mtmarchetti.com

PRODUZIONE MODULI ROTANTI



PAGINA DW 0330-2-00



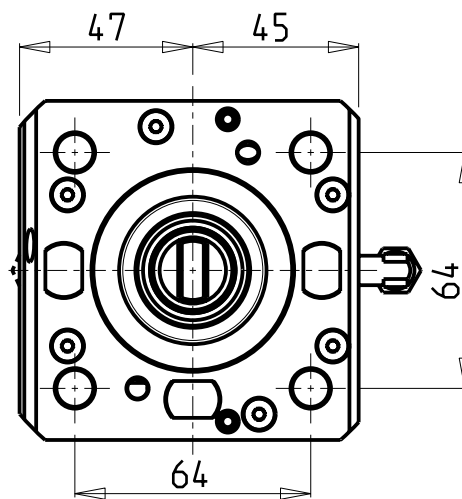
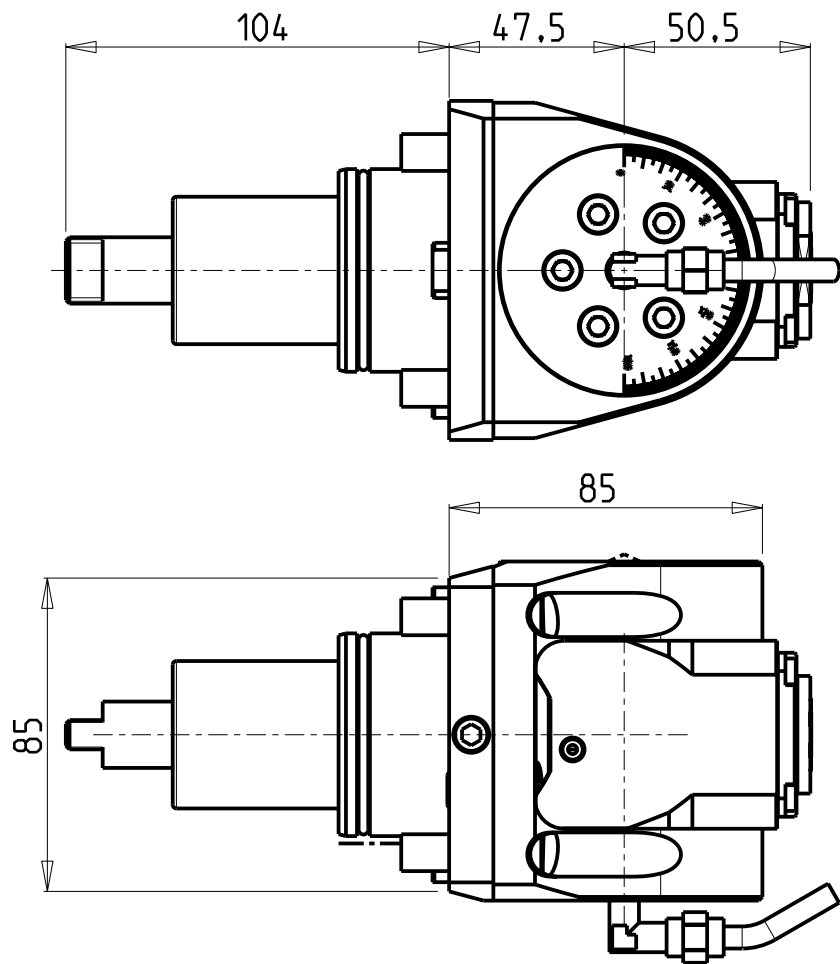

### ATTENZIONE - ATTENTION - ACHTUNG

- Su macchine PUMA 280, PUMA TT1500-TT1800 serie non arriva in centro mandrino.
- On machines PUMA 280, PUMA TT1500-TT1800 series tool does not get to the centre of the spindle axis.
- Auf Maschinen PUMA 280, PUMA TT1500-TT1800 serie erreicht das Werkzeug nicht die Mitte der Werkzeug-Achse.

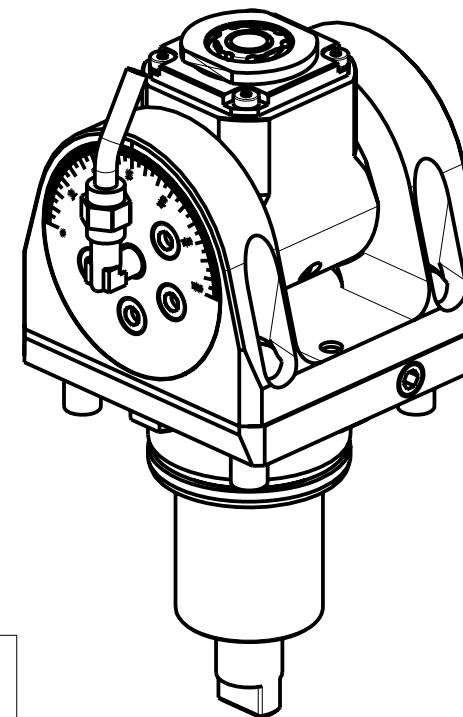

Cod. MT	Mandrino Spindle Spindel	I	RPM	Coppia Max Max Torque Max Drehmoment	Lubrificazione int. Coolant through Innenkuehlung	Lubrificazione est. Ext. coolant Aussenkuehlung	CHIAVI INCLUSE Keys included Schlüssel inbegriffen			
DW 00660120	ERA20	1:1	6000	30Nm		X	CHUB22	CHUB36	CHTAER20ZC	CHESL07
DW 00660220	ERA20	1:1	6000	30Nm	P=70bar	X	CHUB22	CHUB36	CHTAER20ZC	CHESL07

NEW

## DOOSAN BMT 55

MOD: PUMA 230-240M/MS-280LM - PUMA 1500-2000-2500M/MS/Y/SY - LINX 300 M - PUMA 2100 SERIE  
PUMA TT1500-TT1800MS/SY - TL2000-2500 (M) - PUMA GT2100 M

MODULO MOTORIZZATO ORIENTABILE  $\pm 90^\circ$  H=47.5mm

$\pm 90^\circ$  adjustable angle driven tool H=47.5mm

Angetriebenes Werkzeug schwenkbar  $\pm 90^\circ$  H=47.5mm

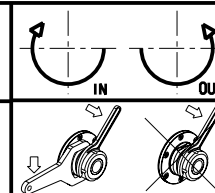

### M.T. srl

Via Casino Albini 480  
Tel. 0541/956034-957884  
Fax 0541/956341

47842 S. GIOVANNI IN M. (RN)  
e-mail: mtma@mtmarchetti.com  
http://www.mtmarchetti.com

PRODUZIONE MODULI ROTANTI



PAGINA DW 0335-2-00

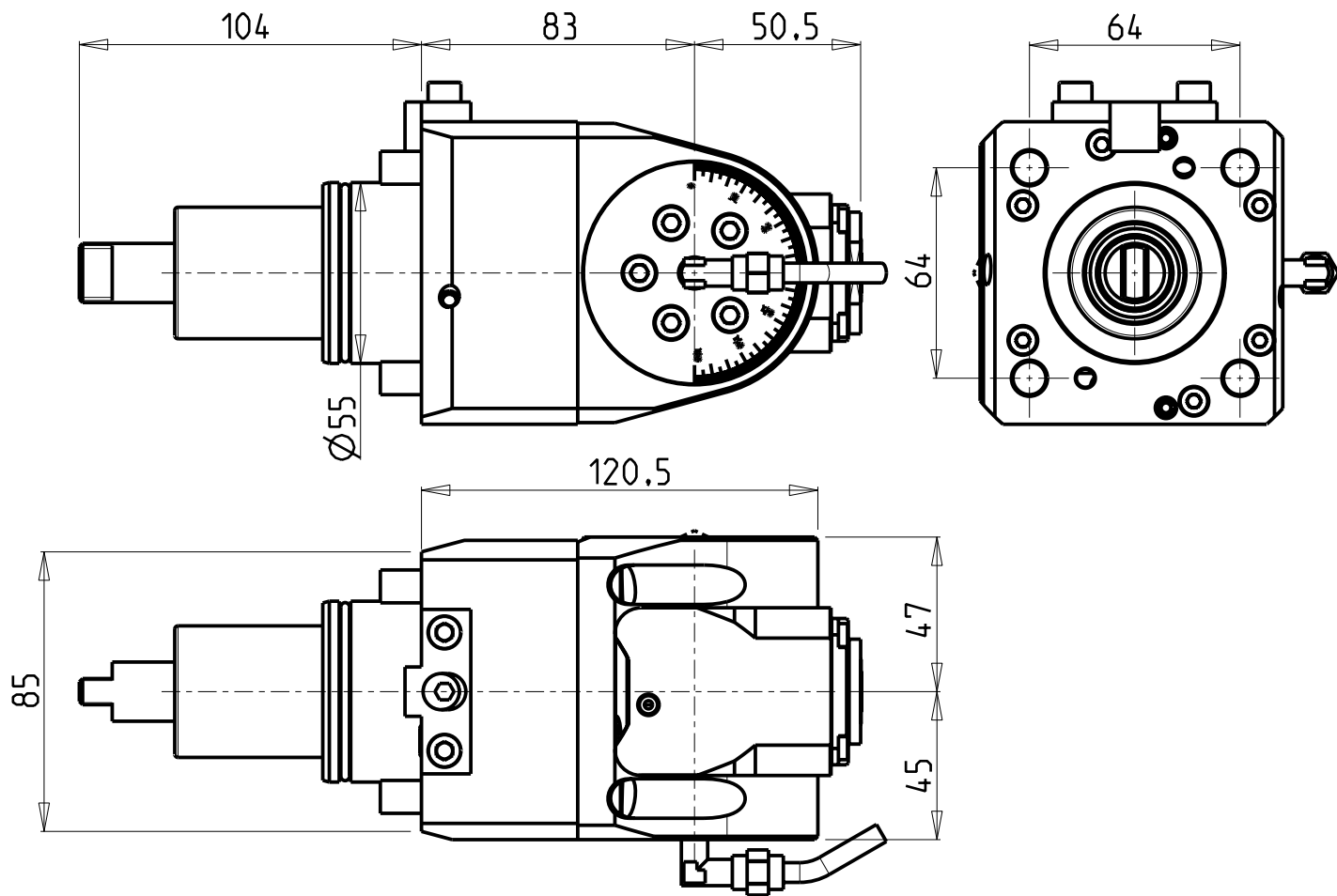

### ATTENZIONE - ATTENTION - ACHTUNG

- VERIFICARE LE MISURE DI INGOMBRO PER POSSIBILE INTERFERENZA SU ALCUNI MODELLI DI MACCHINE
- Please check the overall sizes for possible interferences on some machine models
- Bitte überprüfen sie das ausmass um mögliche interferenzen auf einigen maschinen modellen zu vermeiden

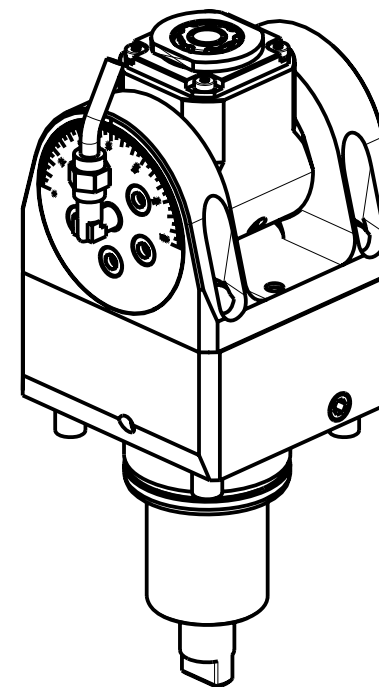

Cod. MT	Mandrino Spindle Spindel	I	RPM	Coppia Max Max Torque Max Drehmoment	Lubrificazione int. Coolant through Innenkuehlung	Lubrificazione est. Ext. coolant Aussenkuehlung	CHIAVI INCLUSE Keys included Schlüssel inbegriffen				
DW 00661120	ERA20	1:1	6000	30Nm		X	CHUB22	CHUB36	CHTAER20ZC	CHESL08	NEW
DW 00661220	ERA20	1:1	6000	30Nm	P=70bar	X	CHUB22	CHUB36	CHTAER20ZC	CHESL08	

### DOOSAN BMT 55

MOD: PUMA 230-240M/MS-280LM - PUMA 1500-2000-2500M/MS/Y/SY - LINX 300 M - PUMA 2100 SERIE  
PUMA TT1500-TT1800MS/SY - TL2000-2500 (M) - PUMA GT2100 M

MODULO MOTORIZZATO ORIENTABILE ±90° H=83mm

±90° adjustable angle driven tool H=83mm

Angetriebenes Werkzeug schwenkbar ±90° H=83mm

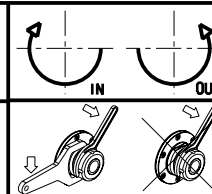

### M.T. srl

Via Casino Albini 480  
Tel. 0541/956034-957884

Fax 0541/956341

47842 S. GIOVANNI IN M. (RN)

e-mail: mtma@mtmarchetti.com

http://www.mtmarchetti.com

PRODUZIONE MODULI ROTANTI



PAGINA DW 0335-2-10

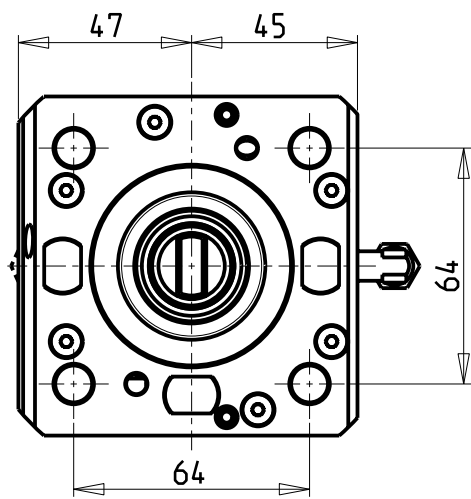
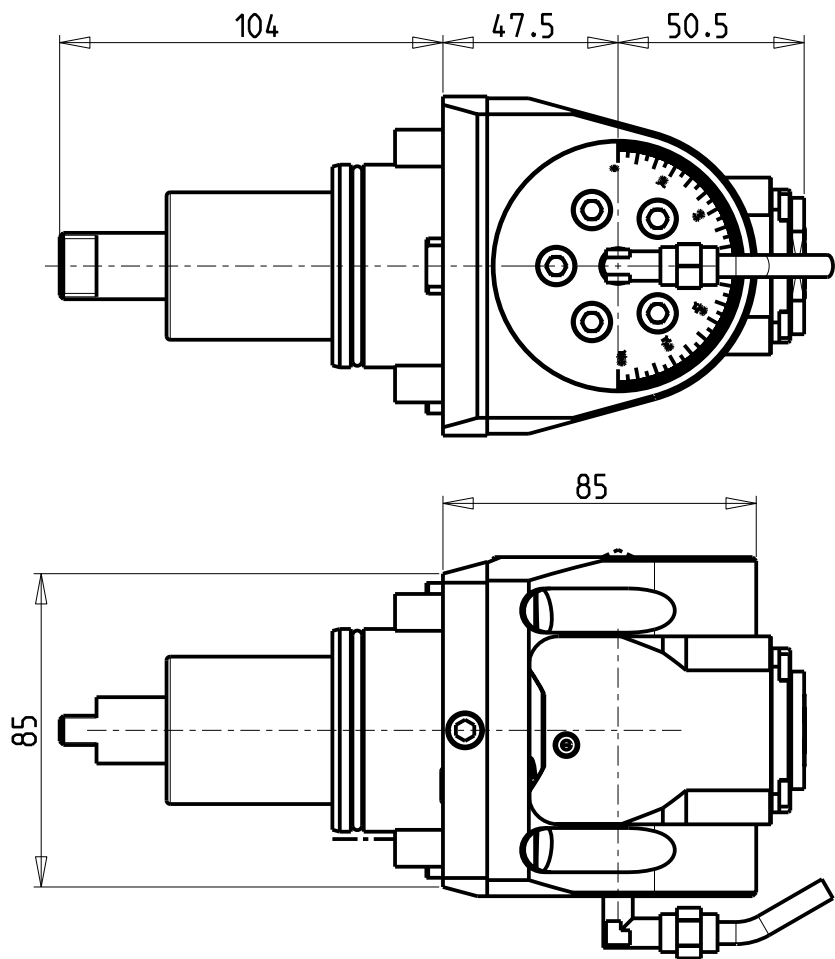

**ATTENZIONE - ATTENTION - ACHTUNG**

- Per lo smontaggio degli utensili utilizzare sempre la chiave di contrasto come indicato nel manuale d'uso.
- For disassembly of the tools use always the contrast key as mentioned in the user instructions.
- Fuer das Abmontieren der Werkzeuge immer den Gegenschlüssel benutzen wie in der Bedienungsanleitung erwäehnt.

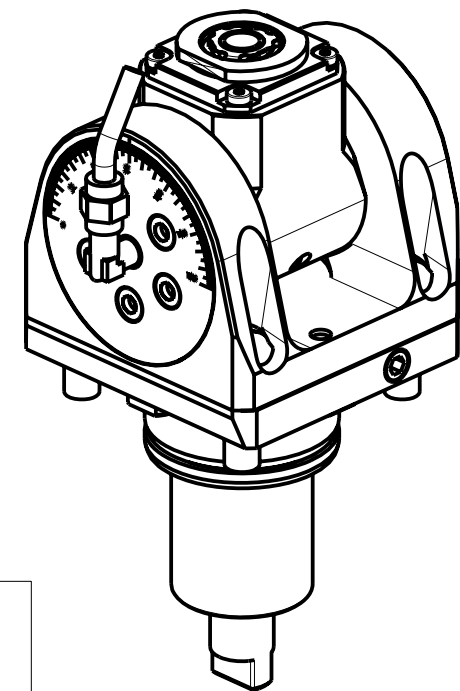

Cod. MT	Mandrino Spindle Spindel	I	RPM	Coppia Max Max Torque Max Drehmoment	Lubrificazione int. Coolant through Innenkuehlung	Lubrificazione est. Ext. coolant Aussenkuehlung	CHIAVI INCLUSE Keys included Schluessel inbegriffen			
DW 00660316	ERA16	1:2	12000	8Nm		X	CHUB19_SP3	CHUB32	CHTAER16ZC	CHESL07
DW 00660416	ERA16	1:2	12000	8Nm	P=70bar	X	CHUB19_SP3	CHUB32	CHTAER16ZC	CHESL07

**DOOSAN BMT 55**  
 MOD: PUMA 230-240M/MS-280LM - PUMA 1500-2000-2500M/MS/Y/SY - LINX 300 M - PUMA 2100 SERIE  
 PUMA TT1500-TT1800MS/SY - TL2000-2500 (M) - PUMA GT2100 M  
 MODULO MOTORIZZATO ORIENTABILE +/-90° MOLTIPLICATO I=1:2 H=47,5mm  
 +/-90° adjustable angle driven tool geared-up I=1:2 H=47.5mm  
 Angetriebenes Werkzeug schwenkbar +/-90° uebersetzt I=1:2 H=47.5mm

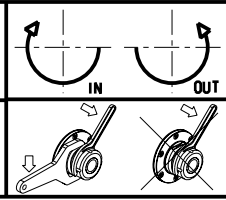

**M.T. srl**  
 Via Casino Albini 480  
 Tel. 0541/956034-957884  
 Fax 0541/956341  
 47842 S. GIOVANNI IN M. (RN)  
 e-mail: mtma@mtmarchetti.com  
 http://www.mtmarchetti.com

PRODUZIONE MODULI ROTANTI

PAGINA DW 0336-2-00

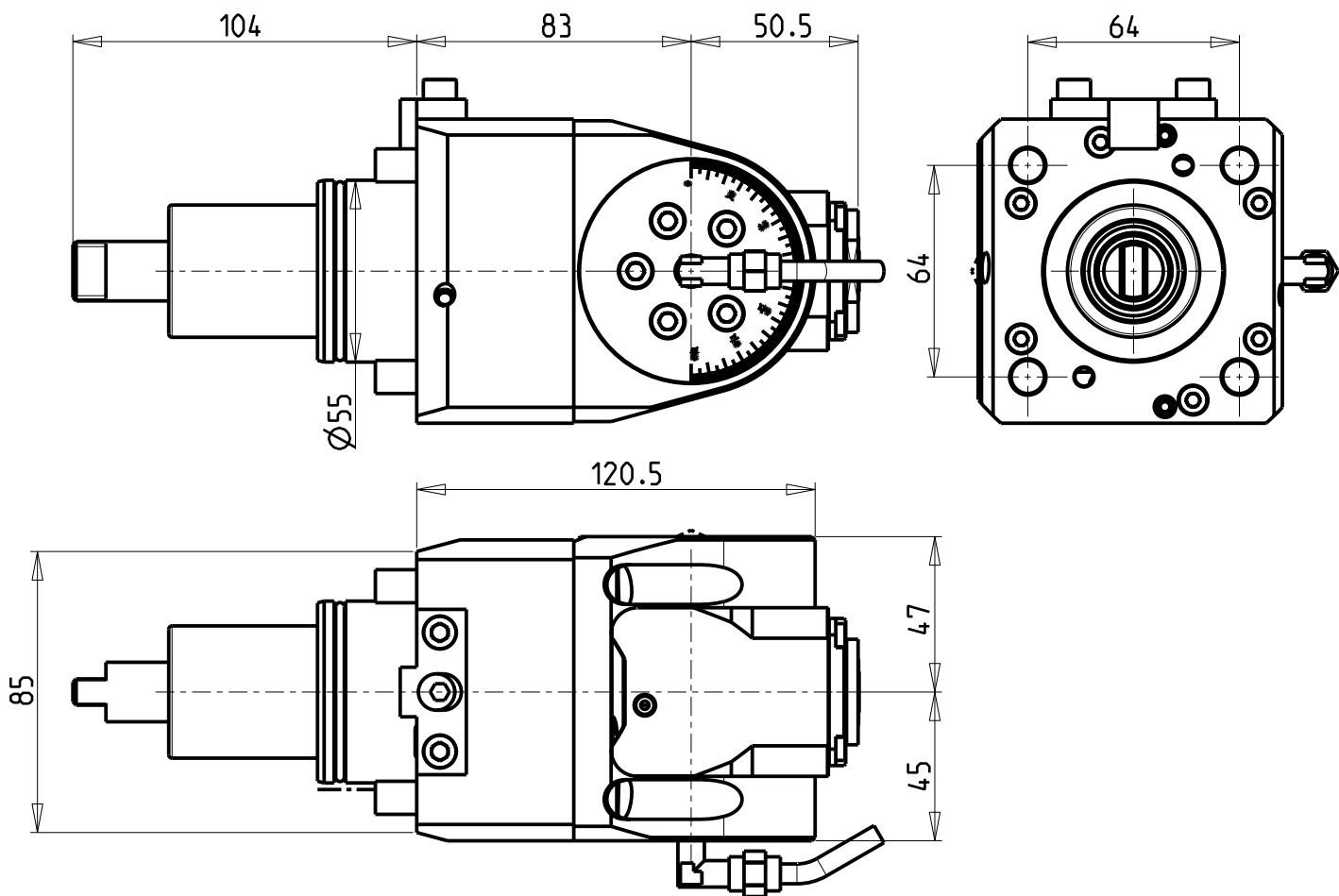

**ATTENZIONE - ATTENTION - ACHTUNG**

- Per lo smontaggio degli utensili utilizzare sempre la chiave di contrasto come indicato nel manuale d'uso.
- For disassembly of the tools use always the contrast key as mentioned in the user instructions.
- Fuer das Abmontieren der Werkzeuge immer den Gegenschlüssel benutzen wie in der Bedienungsanleitung erwahnt.

- ATTENZIONE - ATTENTION - ACHTUNG**
- VERIFICARE LE MISURE DI INGOMBRO PER POSSIBILE INTERFERENZA SU ALCUNI MODELLI DI MACCHINE
  - Please check the overall sizes for possible interferences on some machine models
  - Bitte überprüfen sie das ausmass um mögliche interferenzen auf einigen maschinen modellen zu vermeiden

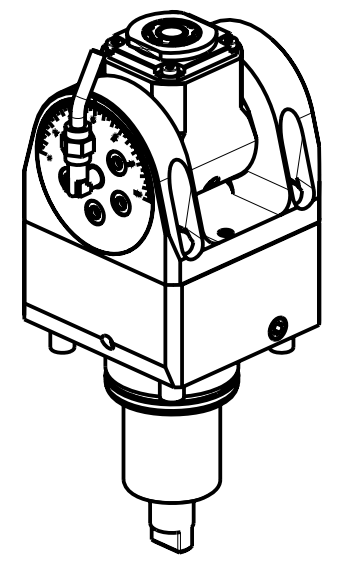

Cod. MT	Mandrino Spindle Spindel	I	RPM	Coppia Max Max Torque Max Drehmoment	Lubrificazione int. Coolant through Innenkuehlung	Lubrificazione est. Ext. coolant Aussenkuehlung	CHIAVI INCLUSE Keys included Schlüssel inbegriffen			
DW 00661316	ERA16	1:2	12000	8Nm		X	CHUB19_SP3	CHUB32	CHTAER16ZC	CHESL08
DW 00661416	ERA16	1:2	12000	8Nm	P=70bar	X	CHUB19_SP3	CHUB32	CHTAER16ZC	CHESL08

**DOOSAN BMT 55**  
 MOD: PUMA 230-240M/MS-280LM - PUMA 1500-2000-2500M/MS/Y/SY - LINX 300 M - PUMA 2100 SERIE  
 PUMA TT1500-TT1800MS/SY - TL2000-2500 (M) - PUMA GT2100 M  
 MODULO MOTORIZZATO ORIENTABILE +/-90° MOLTIPLICATO I=1:2 H=83mm  
 +/-90° adjustable angle driven tool geared-up I=1:2 H=83mm  
 Angetriebenes Werkzeug schwenkbar +/-90° uebersetzt I=1:2 H=83mm

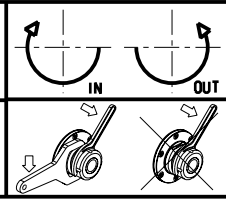

**M.T. srl**  
 Via Casino Albini 480  
 Tel. 0541/956034-957884  
 Fax 0541/956341  
 47842 S. GIOVANNI IN M. (RN)  
 e-mail: mtma@mtmarchetti.com  
 http://www.mtmarchetti.com

PRODUZIONE MODULI ROTANTI

PAGINA DW 0336-2-10

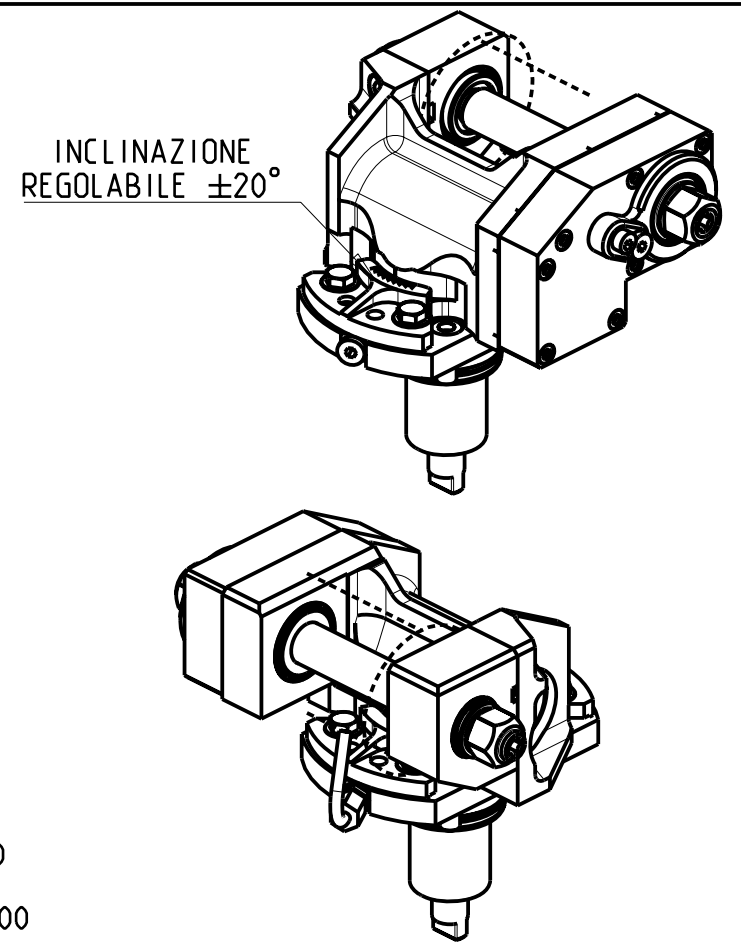
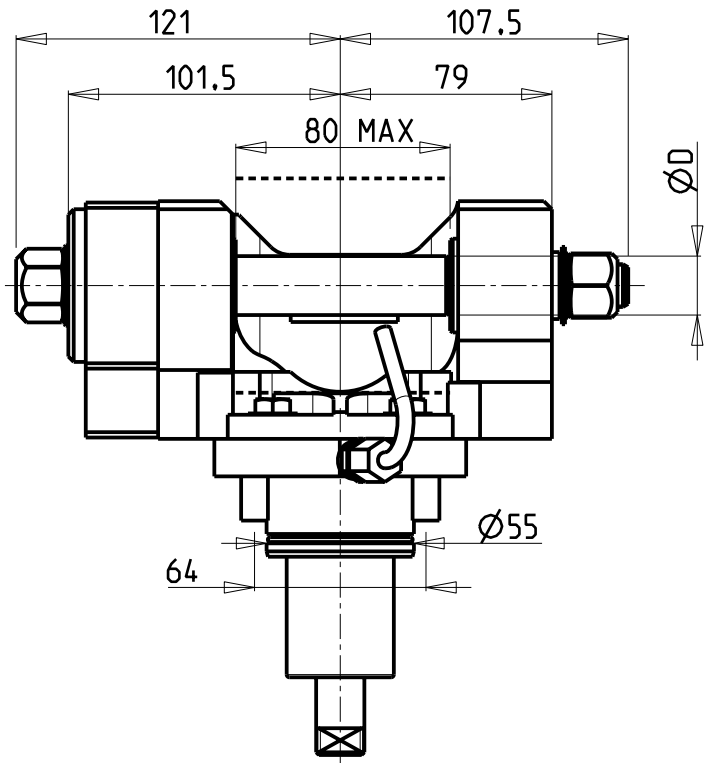
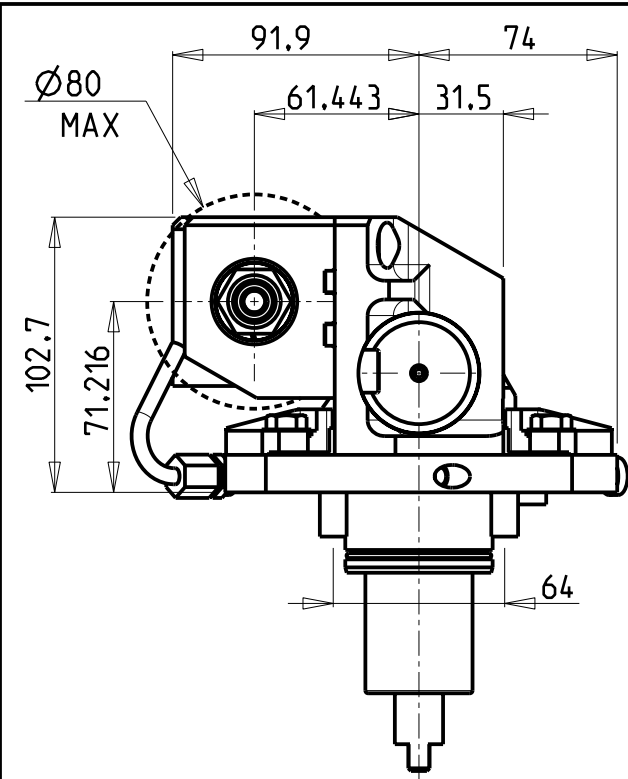

INCLINAZIONE  
REGOLABILE ±20°

**DOTAZIONI - SUPPLIED WITH - AUSSTATTUNG**

mm / inch	- N°1 ALBERO + DISTANZIALI - N°1 SHAFT + SPACER - N°1 DORN + ABSTANDSSTUECK
-----------	---

PER ALBERI E DISTANZIALI VEDI PAG. TBL250-1-00  
FOR SHAFT END SPACER SEE PAGE TBL250-1-00  
FUER DORN UND ABSTANDSSTUECK SEITE TBL250-1-00

Cod. MT	I	RPM max	Coppia Max Max Torque Max Drehmoment	Reversibile lato mandrino/contromandrino Reversible sub/main spindle side Umkehrbare Spindelseite/ Gegenspindelseite	Lubrificazione est. Ext. coolant Aussenkuehlung	D (mm)	D (Inch)	CHIAVI INCLUSE Keys included Schlüssel inbegriffen		
								CHUB24	CHUB13	CHESL08
0621100	1:1	6000	60Nm	X	X	16-22-27-32	3/4"-1"-1 1/4"	CHUB24	CHUB13	CHESL08
0622100	2:1	3000	80Nm	X	X	16-22-27-32	3/4"-1"-1 1/4"	CHUB24	CHUB13	CHESL08

**ATTENZIONE - ATTENTION - ACHTUNG**

- VERIFICARE LE MISURE DI INGOMBRO PER POSSIBILE INTERFERENZA SU ALCUNI MODELLI DI MACCHINE
- Please check the overall sizes for possible interferences on some machine models
- Bitte überprüfen sie das ausmass um mögliche interferenzen auf einigen maschinen modellen zu vermeiden

**DOOSAN BMT 55**  
MOD: PUMA 230-240M/MS-280LM - PUMA 1500-2000-2500M/MS/Y/SY - LINX 300 M - PUMA 2100 SERIE  
PUMA TT1500-TT1800MS/SY - PUMA TL2000-2500 (M) - MX1600/2100TS - PUMA GT2100 M  
MODULO MOTORIZZATO PORTACREATORE  
Driven gear hobber  
Angetriebenes Zahnradwaelzfraes-Werkzeug

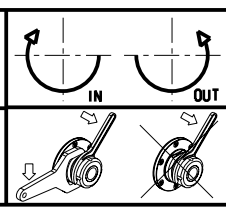

**M.T. srl**  
Via Casino Albini 480  
Tel. 0541/956034-957884  
Fax 0541/956341  
47842 S. GIOVANNI IN M. (RN)  
e-mail: mtma@mtmarchetti.com  
http://www.mtmarchetti.com

PRODUZIONE MODULI ROTANTI

PAGINA DW0340-2-00

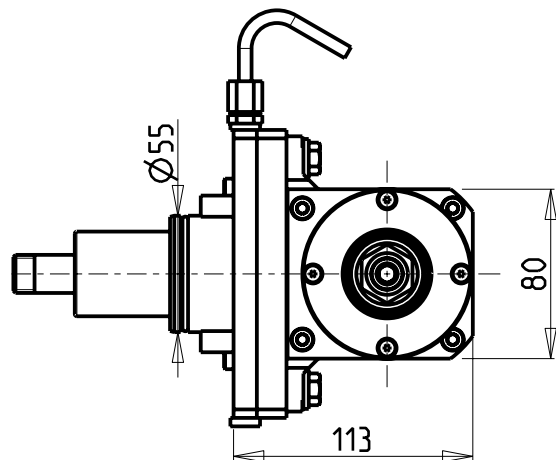
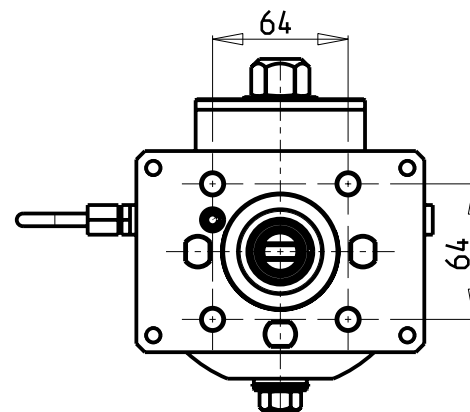
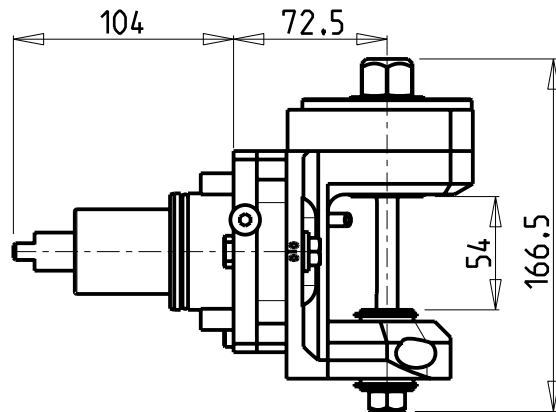
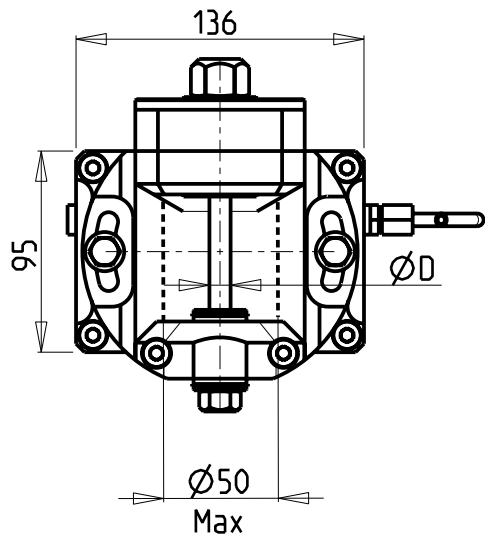

INCLINAZIONE  
REGOLABILE  $\pm 15^\circ$

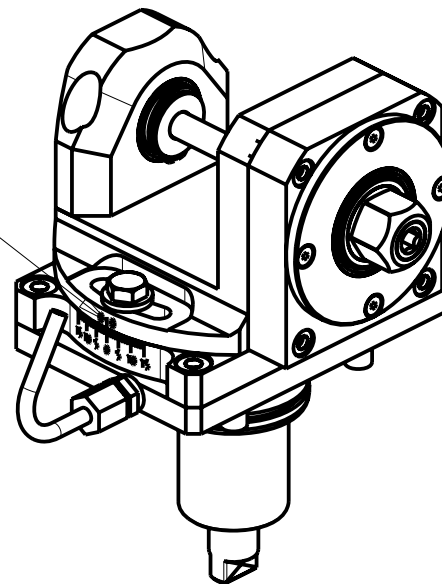

ATTENZIONE - ATTENTION - ACHTUNG

- VERIFICARE LE MISURE DI INGOMBRO PER POSSIBILE INTERFERENZA SU ALCUNI MODELLI DI MACCHINE
- Please check the overall sizes for possible interferences on some machine models
- Bitte überprüfen sie das ausmass um mögliche interferenzen auf einigen maschinen modellen zu vermeiden

Cod. MT	i	RPM max	Coppia Max Max Torque Max Drehmoment	Lubrificazione est. Ext. coolant Aussenkuehlung	D (mm)	CHIAVI INCLUSE Keys included Schluessel inbegriffen					
						CHUB24	CHUB13	CHESL08	CHESL06	CHESL04	
DW 00051108	1:1	6000	50Nm	X	8	CHUB24	CHUB13	CHESL08	CHESL06	CHESL04	
DW 00051110	1:1	6000	50Nm	X	10	CHUB24	CHUB17	CHUB13	CHESL08	CHESL06	CHESL05
DW 00051113	1:1	6000	50Nm	X	13	CHUB24	CHUB19	CHUB13	CHESL08	CHESL06	
DW 00051116	1:1	6000	50Nm	X	16	CHUB24	CHUB13	CHESL08	CHESL06		

DOOSAN BMT 55

MOD: PUMA 230-240M/MS-280LM - PUMA 1500-2000-2500M/MS/Y/SY - LINX 300 M - PUMA 2100 SERIE  
PUMA TT1500-TT1800MS/SY - PUMA TL2000-2500 (M) - MX1600/2100TS - PUMA GT2100 M

MODULO MOTORIZZATO PORTACREATORE RADIALE

Radial driven gear hobber

Radial Angetriebenes Zahnradwaelzfraes-Werkzeug

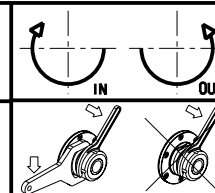

**M.T. srl**

Via Casino Albini 480  
Tel. 0541/956034-957884  
Fax 0541/956341

47842 S. GIOVANNI IN M. (RN)  
e-mail: mtma@mtmarchetti.com  
http://www.mtmarchetti.com

PRODUZIONE MODULI ROTANTI



PAGINA DW 0340-2-30

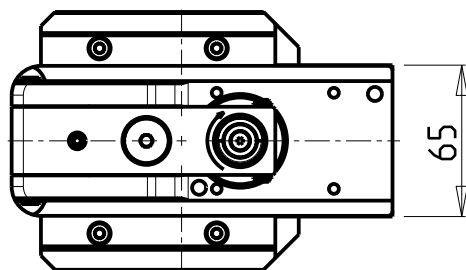
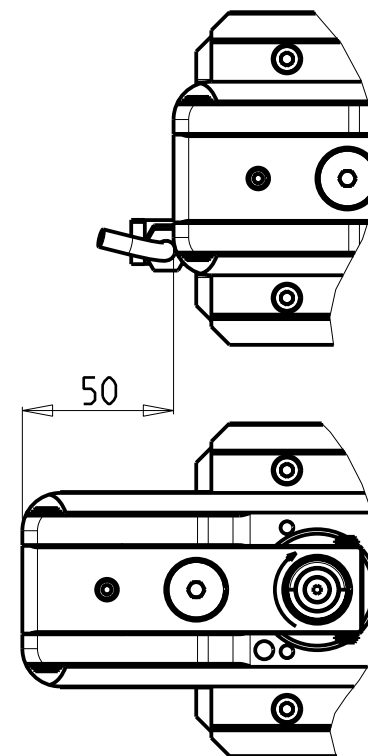
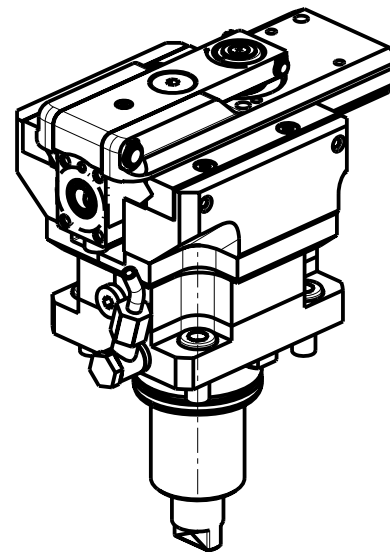
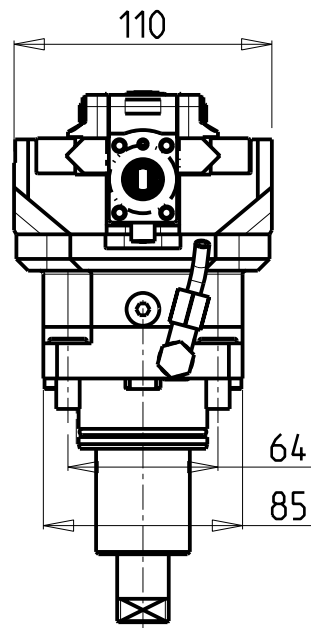
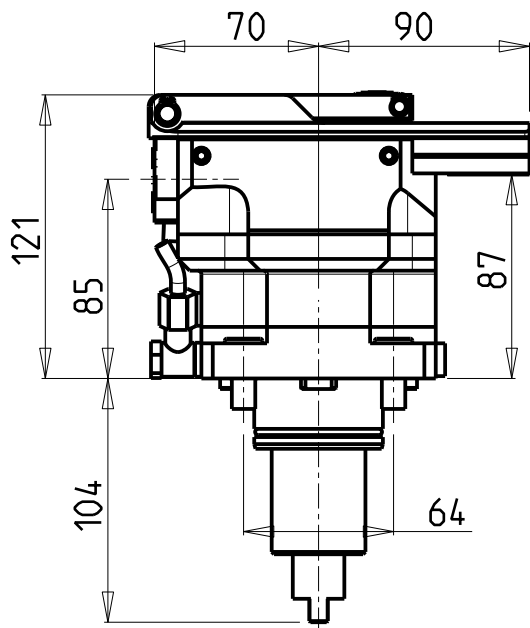

PER UTENSILI STOZZATORI VEDI PAG. TBL400-1-00  
 FOR DRIVEN SLOTTING TOOL CUTTING-TOOLS SEE PAGE TBL400-1-00  
 FÜR NUTENSTOSS-WERKZEUG SCHNEIDWERKZEUGE SIEHE SEITE TBL400-1-00

Cod. MT	I	RPM MAX	Reversibile lato mandrino/contromandrino Reversible sub/main spindle side Umkehrbare Spindel-seite/ Gegenspindel-seite	Lubr. esterna Ext. coolant Aussenkuehlung
DW01030100	4:1	2000	X	X

NEW

DOOSAN BMT 55

MOD: PUMA 230-240M/MS-280LM - PUMA 1500-2000-2500M/MS/Y/SY - LINX 300 M - PUMA 2100 SERIE  
 PUMA TT1500-TT1800MS/SY - PUMA TL2000-2500 (M) - MX1600/2100TS - PUMA GT2100 M

MODULO MOTORIZZATO STOZZATORE

Slotting driven tool

Keilnutenstossmaschine

**M.T. srl**

Via Casino Albini 480  
 Tel. 0541/956034-957884  
 Fax 0541/956341  
 47842 S. GIOVANNI IN M. (RN)  
 e-mail: mtma@mtmarchetti.com  
 http://www.mtmarchetti.com

PRODUZIONE MODULI ROTANTI



PAGINA DW0360-2-00

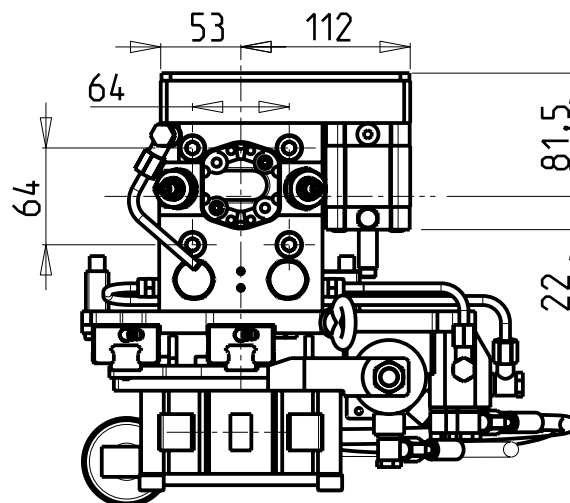
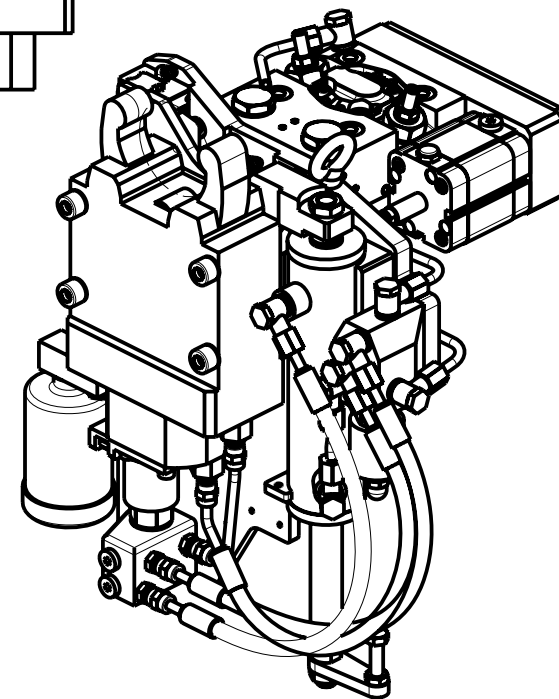
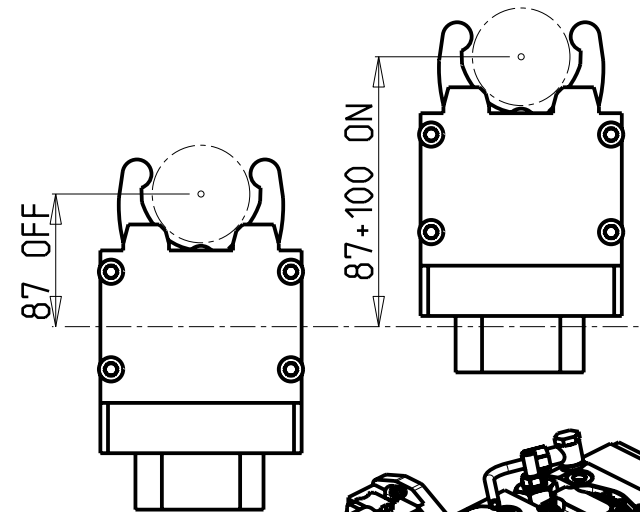
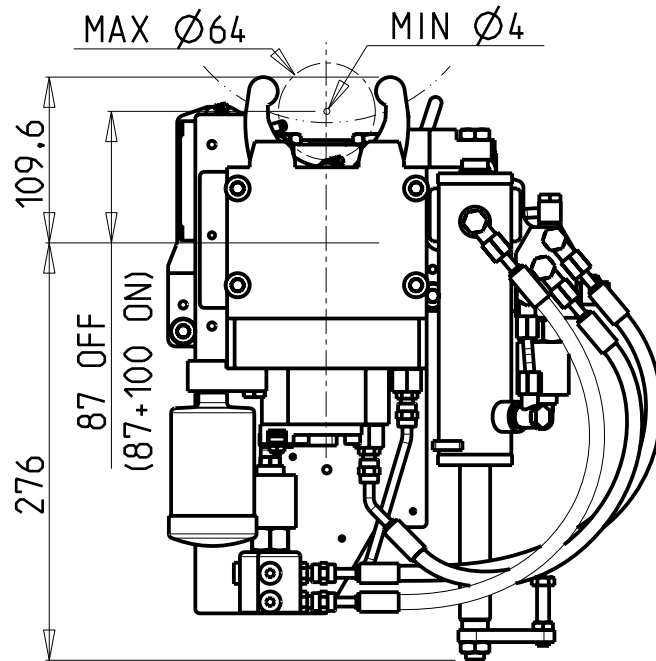
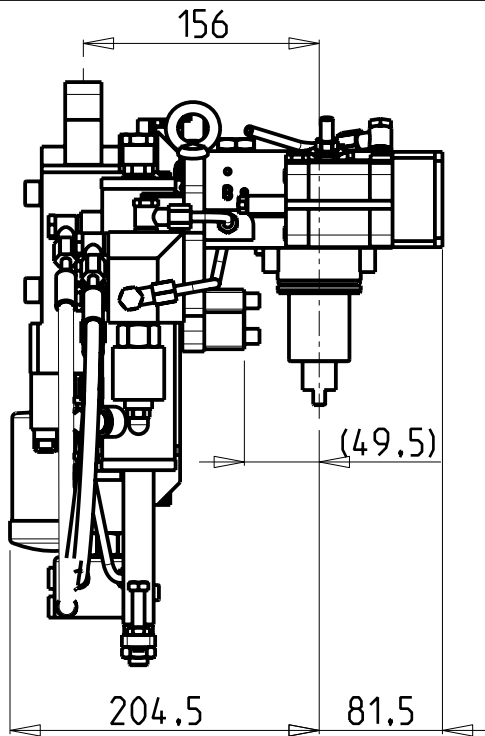

(( ))	#	CON GESTIONE ELETTRONICA APERTURA COMPLETA DELLA LUNETTA
	#	With Electronic control of steady rest arms complete opening
	#	Mit vollstaendiger elektronischer Oeffnungsbedienung der Luenette

Cod. MT	I	RPM	Lubr.esterna Ext. coolant Aussenkuehlung	
DW00930300	1:1	6000	X	NEW
# DW00930300A	1:1	6000	X	NEW

DOOSAN BMT 55  
 MOD: PUMA TT1500-TT1800MS/SY - PUMA TL2000-2500 (M) - MX1600/2100TS

MODULO MOTORIZZATO PER LUNETTA RETRATTILE (TAGLIA 1)  
 Driven toolholder for sliding steady rest (Size 1)  
 Luenettenwerkzeug zurueck versetzte Version (Groesse 1)

**M.T. srl**

Via Casino Albini 480  
 Tel. 0541/956034-957884  
 Fax 0541/956341  
 47842 S. GIOVANNI IN M. (RN)  
 e-mail: mtma@mtmarchetti.com  
 http://www.mtmarchetti.com

PRODUZIONE MODULI ROTANTI



PAGINA DW0363-2-00



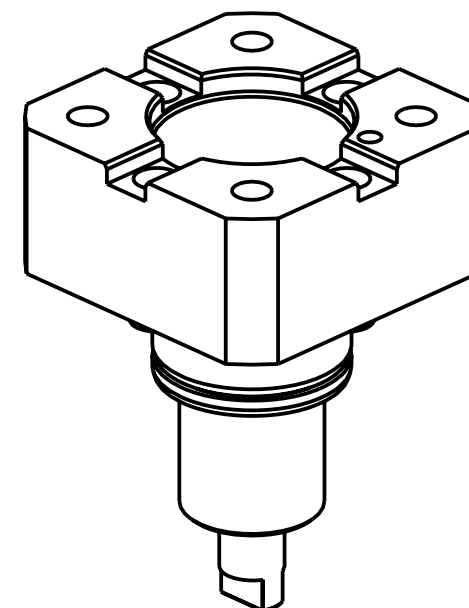
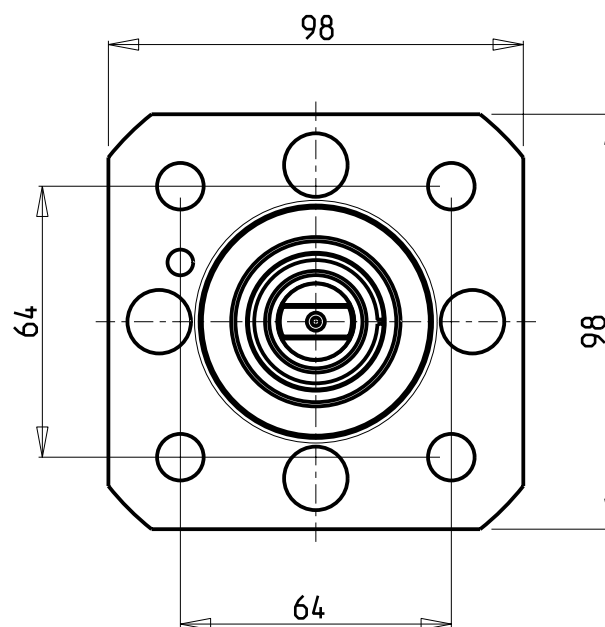
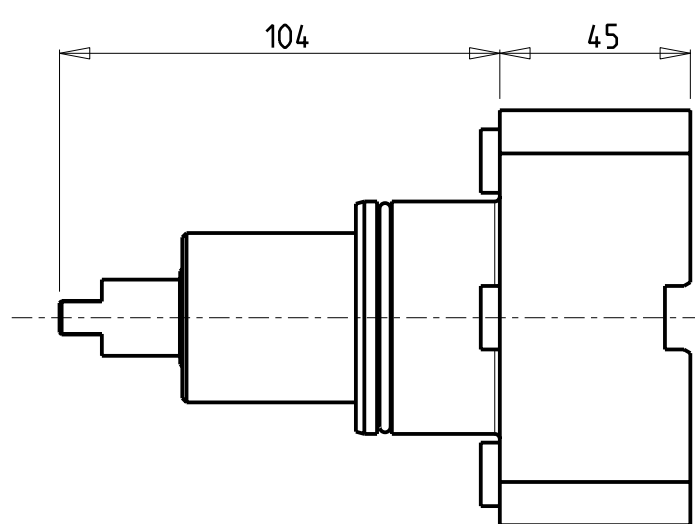

**ATTENZIONE - ATTENTION - ACHTUNG**

- PERICOLO COLLISIONE PEZZO FUORI VOLTEGGIO
- Danger of collision! Tooling out of interference
- Kollisionsgefahr! Werkzeug ausser Interferenz

Cod. MT

DW 00010130

**DOOSAN BMT 55**

MOD: PUMA 230-240M/MS-280LM - PUMA 1500-2000-2500M/MS/Y/SY - LINX 300 M - PUMA 2100 SERIE  
 PUMA TT1500-TT1800MS/SY - PUMA TL2000-2500 (M) - MX1600/2100TS - PUMA GT2100 M

INTERFACCIA PER MODULI BMT55 H=45mm

BMT55 tooling adapter cartridge H=45mm

Adapter Patrone fuer BMT55 Werkzeuge H=45mm

**M.T. srl**

Via Casino Albini 480  
 Tel. 0541/956034-957884  
 Fax 0541/956341  
 47842 S. GIOVANNI IN M. (RN)  
 e-mail: mtma@mtmarchetti.com  
 http://www.mtmarchetti.com

PRODUZIONE MODULI ROTANTI



PAGINA DW 0385-2-00

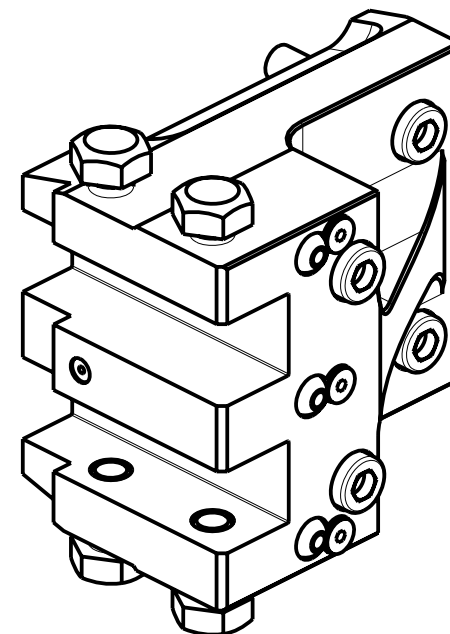
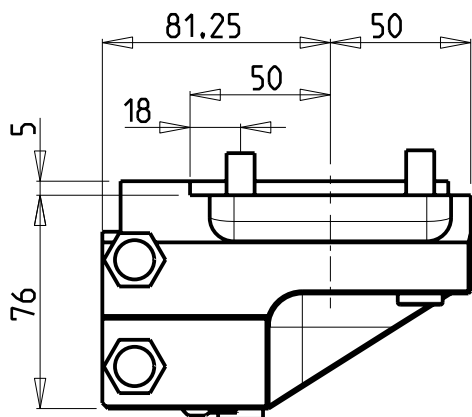
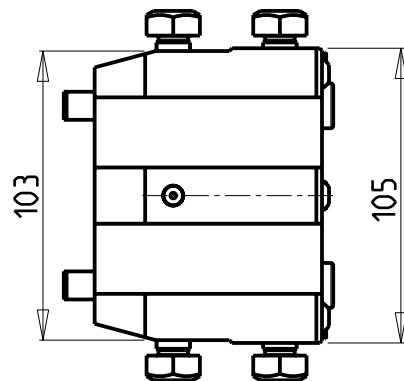
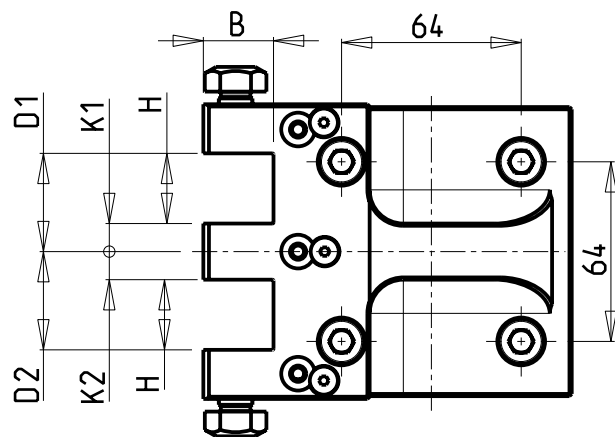

Cod. MT	N°Utensili N°Tools N°Werkzeuge	Reversibile lato mandrino/contromandrino Reversible sub/main spindle side Umkehrbare Spindel-seite/ Gegenspindel-seite	Misure Dimensions Masse	H	B	K1	K2	D1	D2
0772500	2	X	mm	25	25	10	10	35	35
0772540	2	X	inch	1"	1"	3/8"	3/8"	1 3/8"	1 3/8"

## DOOSAN BMT 55

MOD: PUMA 230-240M/MS-280LM - PUMA 1500-2000-2500M/MS/Y/SY - PUMA 2100 SERIE - PUMA TT1500-TT1800MS/SY  
PUMA TL2000-2500 (M)

PORTAUTENSILE RADIALE SOVRAPPOSTO

Radial single side twin static tool

Radial Werkzeughalter ueberlagert

**M.T. srl**

Via Casino Albini 480  
Tel. 0541/956034-957884  
Fax 0541/956341  
47842 S. GIOVANNI IN M. (RN)  
e-mail: mtma@mtmarchetti.com  
http://www.mtmarchetti.com

PRODUZIONE MODULI ROTANTI



PAGINA DW0442-2-00

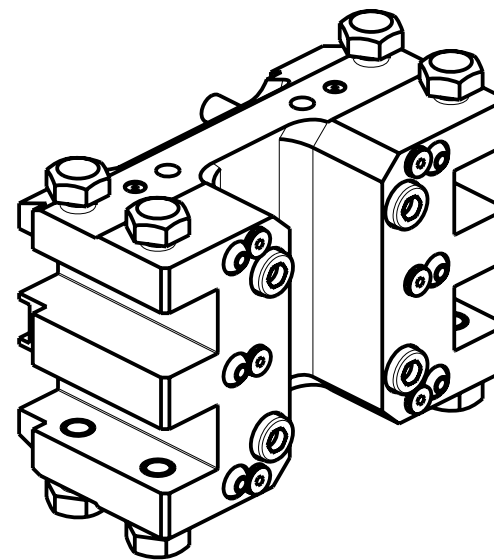
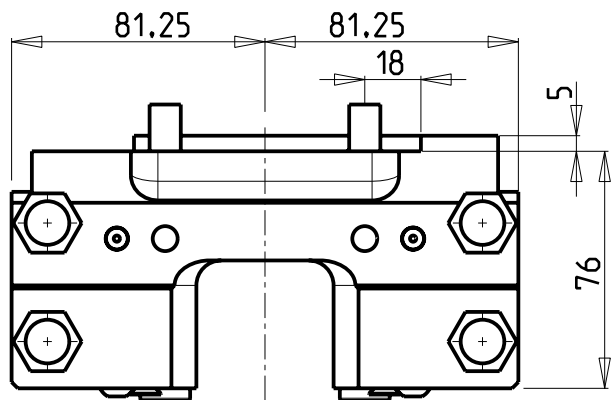
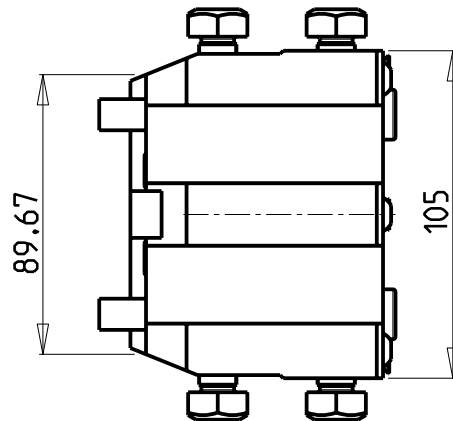
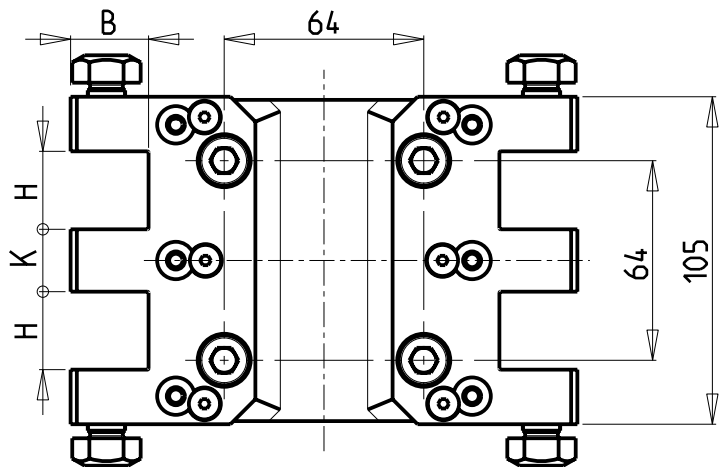

Cod. MT	N°Utensili N°Tools N°Werkzeuge	Reversibile lato mandrino/contromandrino Reversible sub/main spindle side Umkehrbare Spindel-seite/ Gegenspindel-seite	Misure Dimensions Masse	H	K	B
0762500	4	X	mm	25	20	25
0762540	4	X	inch	1"	3/4"	1"

## DOOSAN BMT 55

MOD: PUMA 230-240M/MS-280LM - PUMA 1500-2000-2500M/MS/Y/SY - PUMA 2100 SERIE - PUMA TT1500-TT1800MS/SY  
PUMA TL2000-2500 (M)

PORTAUTENSILE RADIALE DOPPIO SOVRAPPOSTO

Radial double side twin static tool

Radial Doppel-Werkzeughalter ueberlagert

**M.T. srl**

Via Casino Albini 480  
Tel. 0541/956034-957884  
Fax 0541/956341  
47842 S. GIOVANNI IN M. (RN)  
e-mail: mtma@mtmarchetti.com  
http://www.mtmarchetti.com

PRODUZIONE MODULI ROTANTI



PAGINA DW 0463-2-00

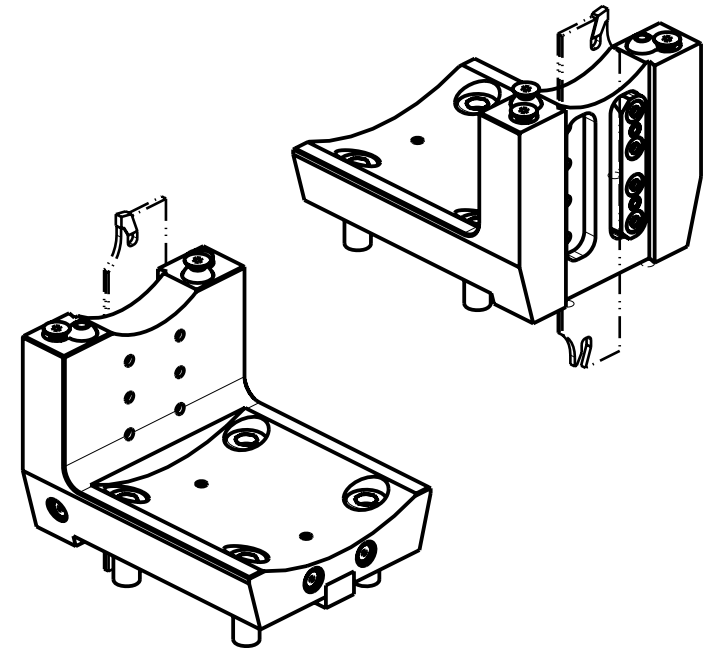
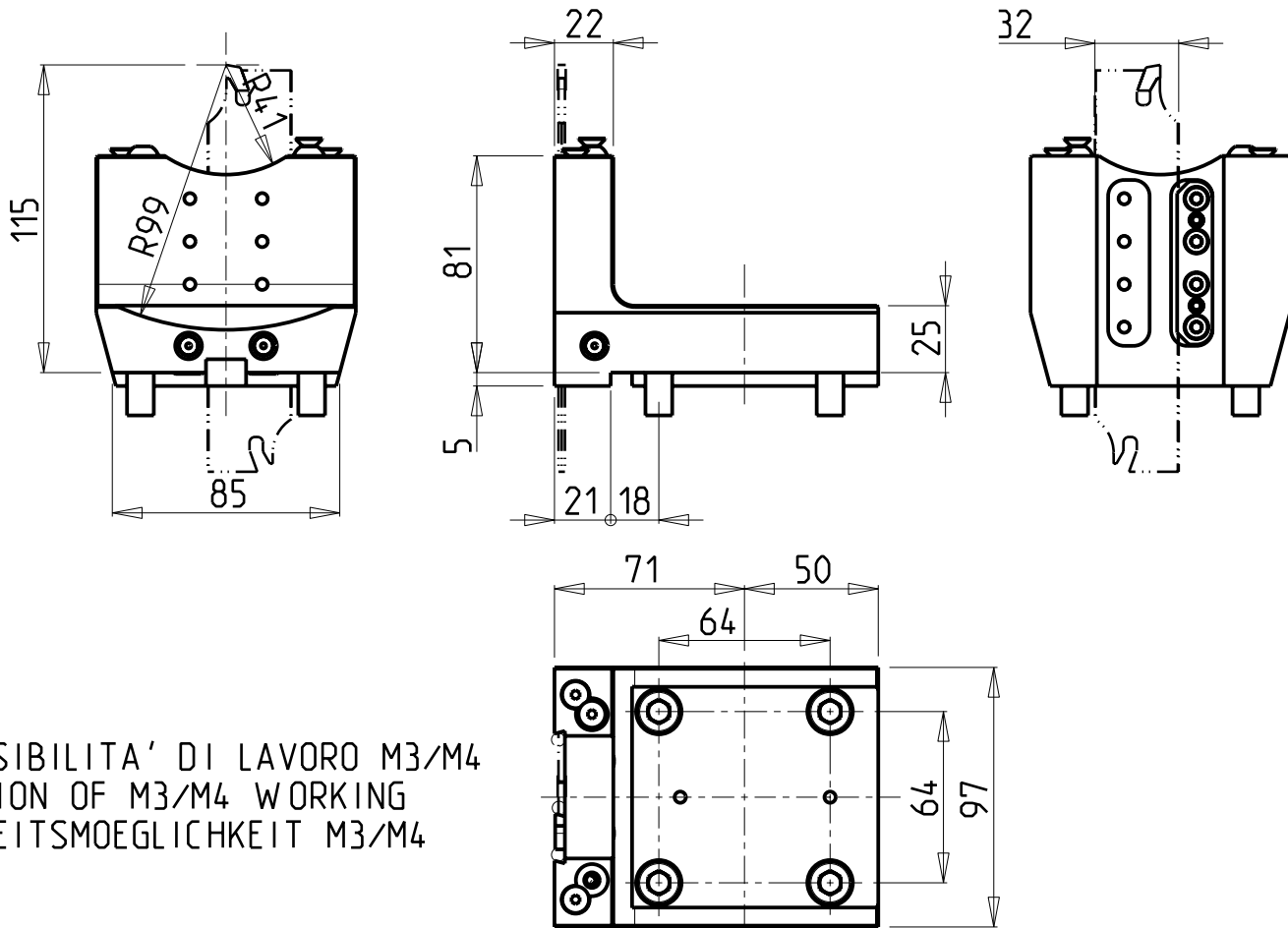

POSSIBILITA' DI LAVORO M3/M4  
 OPTION OF M3/M4 WORKING  
 ARBEITSMOEGlichkeit M3/M4

**DOTAZIONI - SUPPLIED WITH - AUSSTATTUNG**

- N°1 - LAMA - BLADE - KLINGE ISCAR H=32 Sp. 3/4mm (KENNAMETAL OPTIONAL)
- N°10 - INSERTI - INSERTS - EINLAGEN
- N°1 - CHIAVE A T PER MONTAGGIO INSERTI  
 - T-WRENCH FOR INSERT SET UP  
 - T-SCHLUESSEL FUER EINSATZSTUECK-MONTAGE

Cod. MT	N°Utensili N°Tools N°Werkzeuge	Reversibile lato mandrino/contromandrino Reversible sub/main spindle side Umkehrbare Spindel-seite/ Gegenspindel-seite	Lubr.esterna Ext. coolant Aussenkuehlung
DW 00730132	1	X	X

NEW

**DOOSAN BMT 55**

MOD: PUMA 230-240M/MS-280LM - PUMA 1500-2000-2500M/MS/Y/SY - LINX 300 M - PUMA 2100 SERIE  
 PUMA TT1500-TT1800MS/SY - PUMA TL2000-2500 (M) - MX1600/2100TS - PUMA GT2100 M

PORTAUTENSILE RADIALE PER LAMA

Radial blade holder

Radial Abstechhalter

**M.T. srl**

Via Casino Albini 480  
 Tel. 0541/956034-957884  
 Fax 0541/956341  
 47842 S. GIOVANNI IN M. (RN)  
 e-mail: mtma@mtmarchetti.com  
 http://www.mtmarchetti.com

PRODUZIONE MODULI ROTANTI



PAGINA DW 0510-2-00

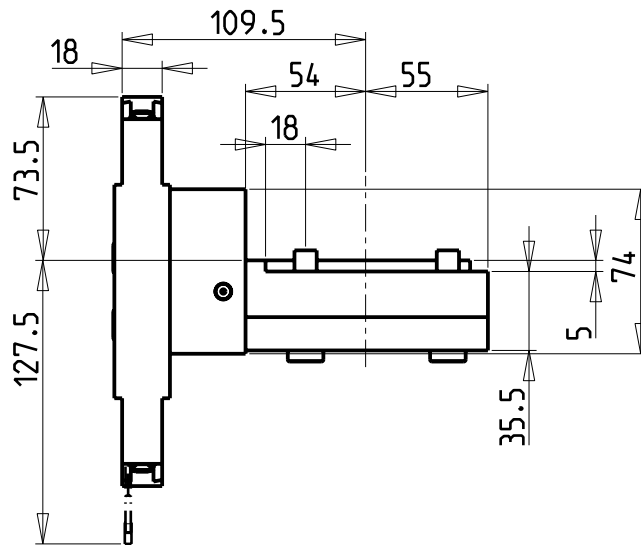
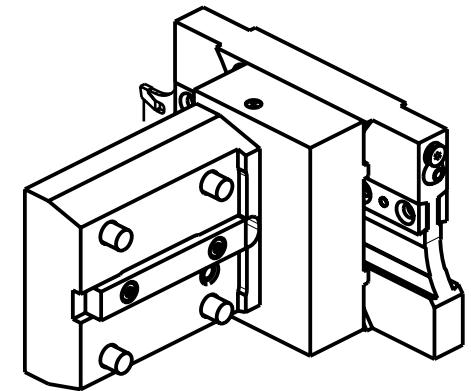
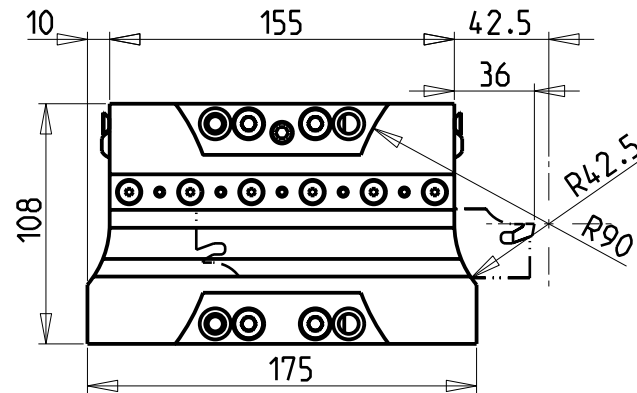
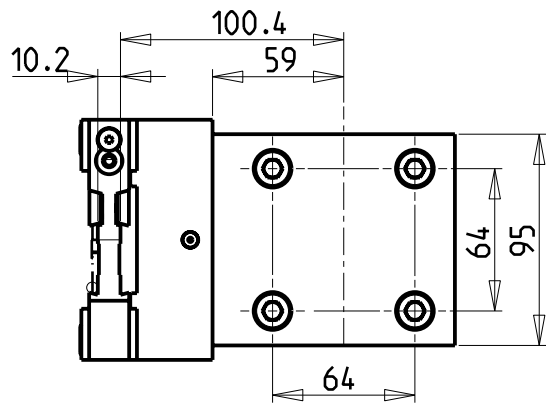

POSSIBILITA' DI LAVORO M3/M4  
 OPTION OF M3/M4 WORKING  
 ARBEITSMÖGLICHKEIT M3/M4

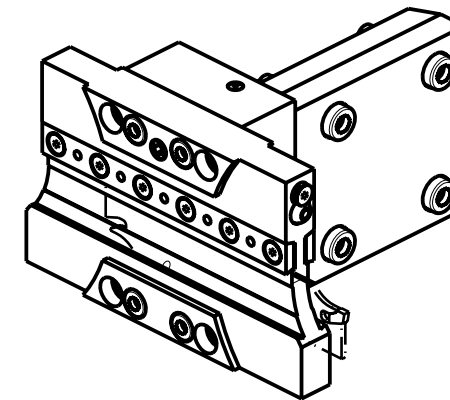

ATTENZIONE - ATTENTION - ACHTUNG  
 - FINO AD ESAURIMENTO SCORTE  
 - clearance sale  
 - solange vorrat

**DOTAZIONI - SUPPLIED WITH - AUSSTATTUNG**  
 N°1 - LAMA - BLADE - KLINGE ISCAR H=32 Sp. 3/4mm  
 (KENNAMETAL OPTIONAL)  
 N°10 - INSERTI - INSERTS - EINLAGEN  
 N°1 - CHIAVE A T PER MONTAGGIO INSERTI  
 - T-WRENCH FOR INSERT SET UP  
 - T-SCHLUESSEL FUER EINSATZSTUECK-MONTAGE

Cod. MT	N°Utensili N°Tools N°Werkzeuge
0790132	1

**DOOSAN BMT 55**  
 MOD: PUMA 230-240M/MS-280LM - PUMA 1500-2000-2500M/MS/Y/SY - LINX 300 M - PUMA 2100 SERIE  
 PUMA TT1500-TT1800MS/SY - PUMA TL2000-2500 (M) - MX1600/2100TS - PUMA GT2100 M  
 PORTAUTENSILE PER LAMA DOPPIO  
 Radial double blade holder  
 Radial Doppel-Abstechhalter



**M.T. srl**  
 Via Casino Albini 480  
 Tel. 0541/956034-957884  
 Fax 0541/956341  
 47842 S. GIOVANNI IN M. (RN)  
 e-mail: mtma@mtmarchetti.com  
 http://www.mtmarchetti.com

PRODUZIONE MODULI ROTANTI



PAGINA DW 0520-2-00

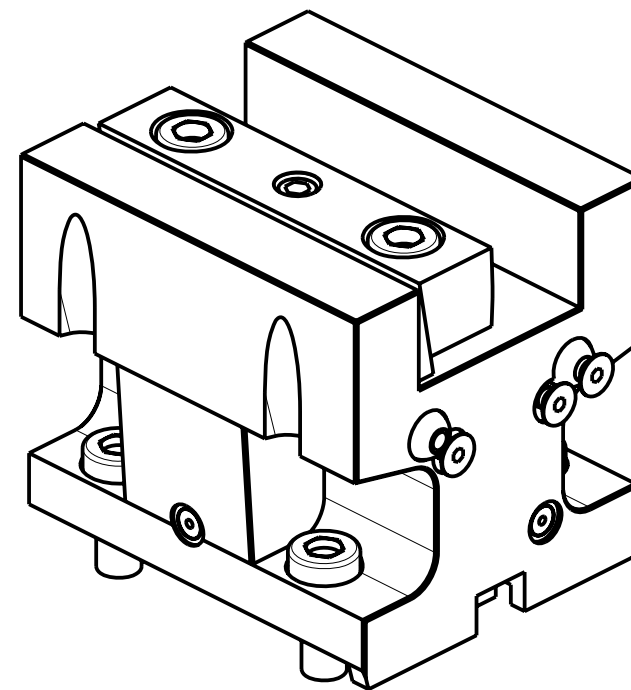
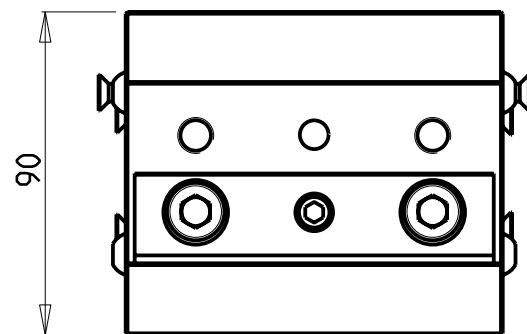
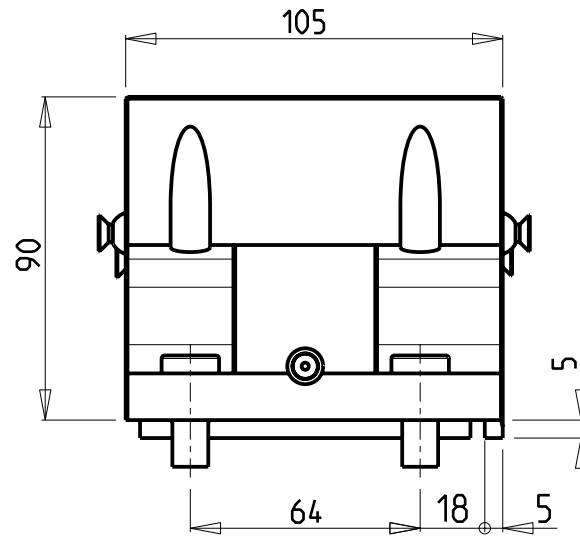
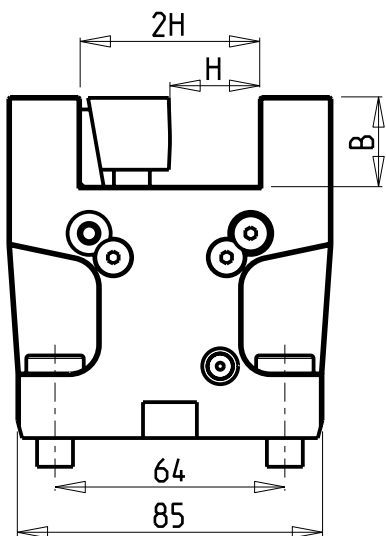

Cod. MT	N°Utensili N°Tools N°Werkzeuge	Reversibile lato mandrino/contromandrino Reversible sub/main spindle side Umkehrbare Spindel-seite/ Gegenspindel-seite	Misure Dimensions Masse	B	H
DW00422500	1	X	mm	25	25
DW00422540	1	X	Inch	1"	1"

## DOOSAN BMT 55

MOD: PUMA 230-240M/MS-280LM - PUMA 1500-2000-2500M/MS/Y/SY - LINX 300 M - PUMA 2100 SERIE  
PUMA TT1500-TT1800MS/SY - PUMA TL2000-2500 (M) - MX1600/2100TS - PUMA GT2100 M

PORTAUTENSILE ASSIALE SINGOLO

Axial single static tool

Axial Single-Werkzeughalter

**M.T. srl**

Via Casino Albini 480  
Tel. 0541/956034-957884  
Fax 0541/956341  
47842 S. GIOVANNI IN M. (RN)  
e-mail: mtma@mtmarchetti.com  
http://www.mtmarchetti.com

PRODUZIONE MODULI ROTANTI



PAGINA DW 0552-2-00

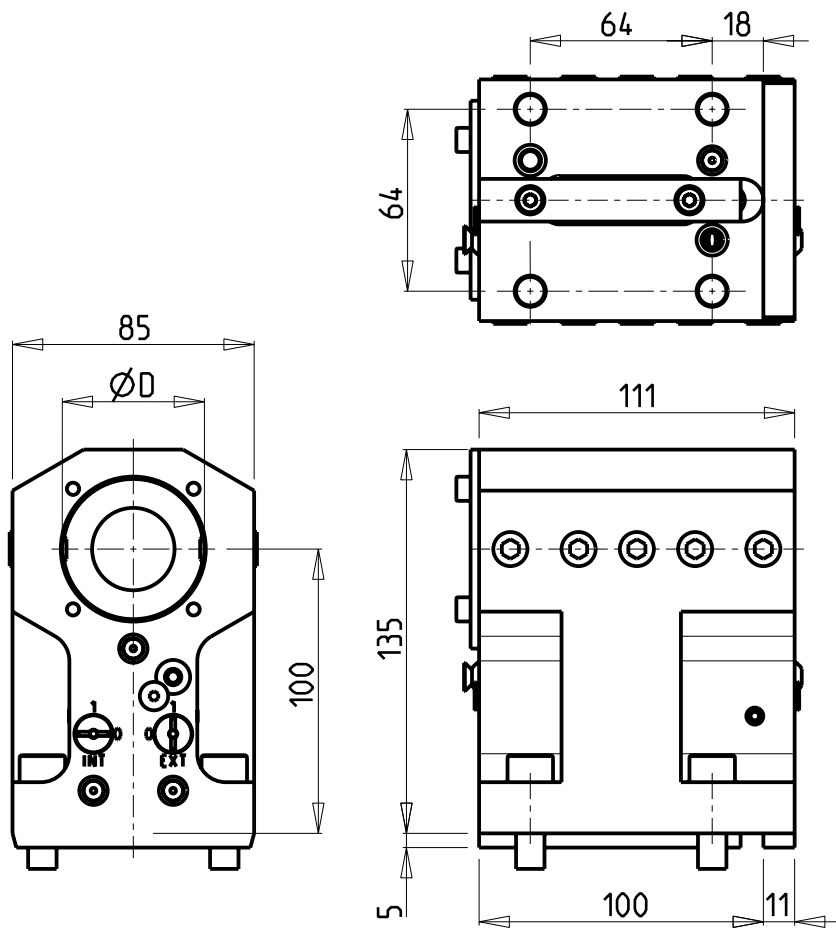

PER BOCCOLE DI RIDUZIONE VEDI PAG. TBL150-1-00  
 FOR REDUCING BUSHINGS SEE PAGE TBL150-1-00  
 FÜR REDUZIERBUCHSE SIEHE SEITE TBL150-1-00

KIT ADDUZIONE INTERNA (OPZIONALE)  
 KIT FOR INTERNAL COOLANT (OPTIONAL)  
 KIT FÜR INTERNE KUEHLMITTELZUFUHR (OPTIONAL)  
 Ø50-Ø2" cod. KIT1000002

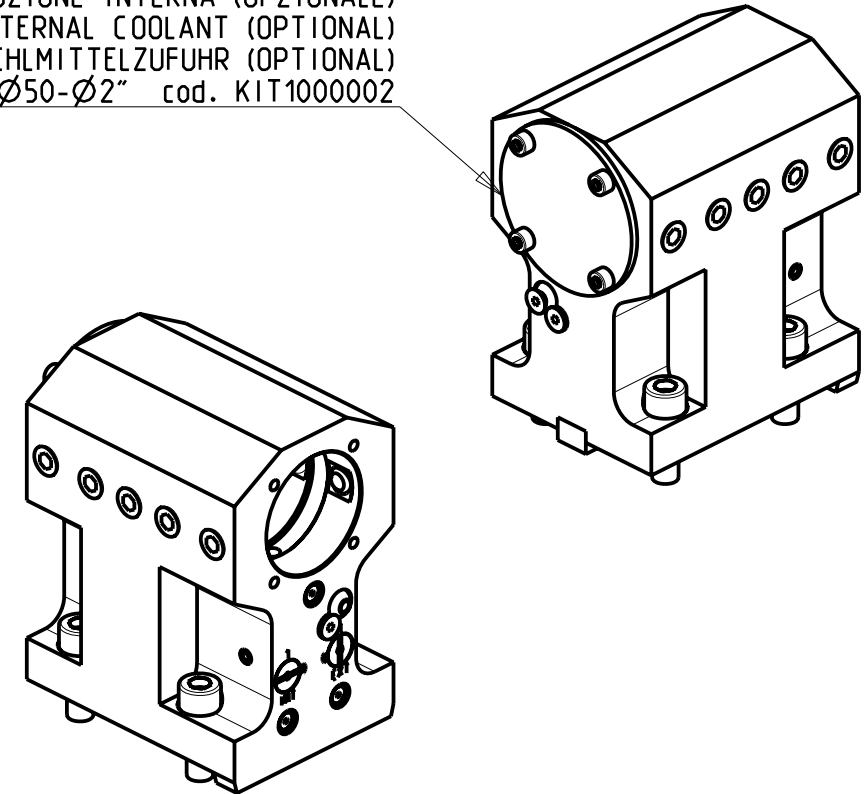

Cod. MT	N°Utensili N°Tools N°Werkzeuge	Reversibile lato mandrino/contromandrino Reversible sub/main spindle side Umkehrbare Spindelseite/ Gegenspindelseite	Lubrificazione int. opzionale Coolant through optional Innenkuehlung Optional	Lubrificazione est. Ext. coolant Aussenkuehlung	Misure Dimensions Masse	D
DW 01115000	1	X	X	X	mm	50
DW 01115080	1	X	X	X	Inch	2"

NEW  
NEW

**DOOSAN BMT 55**  
 MOD: PUMA 230-240M/MS-280LM - PUMA 1500-2000-2500M/MS/Y/SY - PUMA 2100 SERIE - PUMA TT1500-TT1800MS/SY  
 PUMA TL2000-2500 (M) - MX1600/2100TS

PORTAUTENSILE ASSIALE PER BARENO Ø50mm / Ø2" H=100mm  
 Axial single boring bar holder Ø50mm / Ø2" H=100mm  
 Axial Bohrhälter Ø50mm / Ø2" H=100mm

**M.T. srl**  
 Via Casino Albini 480  
 Tel. 0541/956034-957884  
 Fax 0541/956341  
 47842 S. GIOVANNI IN M. (RN)  
 e-mail: mtma@mtmarchetti.com  
 http://www.mtmarchetti.com

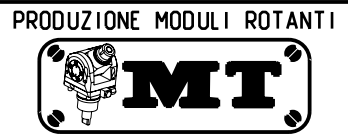

PAGINA DW 0620-2-10

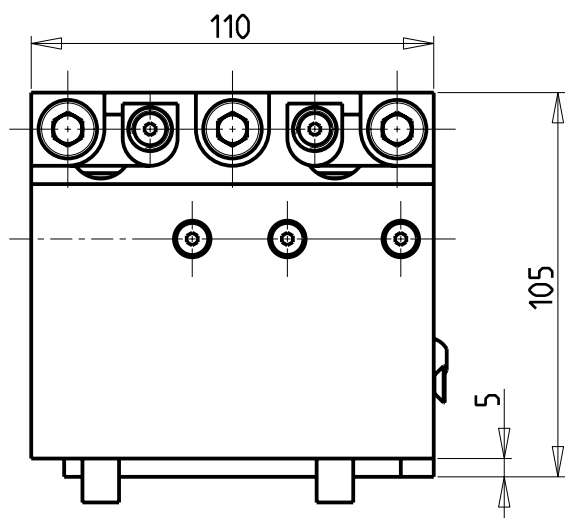
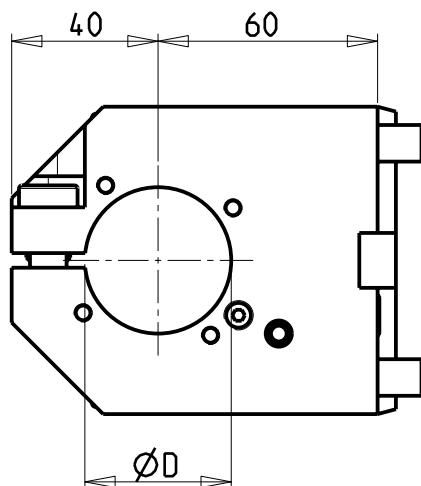
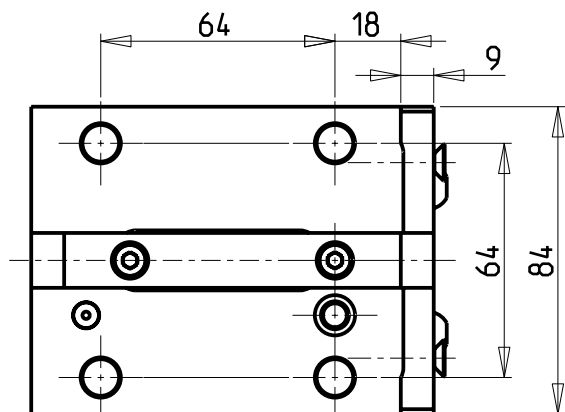

KIT ADDUZIONE INTERNA (OPZIONALE)  
 KIT FOR INTERNAL COOLANT (OPTIONAL)  
 KIT FUER INTERNE KUEHLMITTELZUFUHR (OPTIONAL)  
 Ø40 cod. KIT1003003  
 Ø1 1/2" cod. KIT1003004

SOLO GUARNIZIONE (OPZIONALE)  
 ONLY SEAL (OPTIONAL)  
 NUR DICHTUNG (OPTIONAL)  
 cod. 0520013

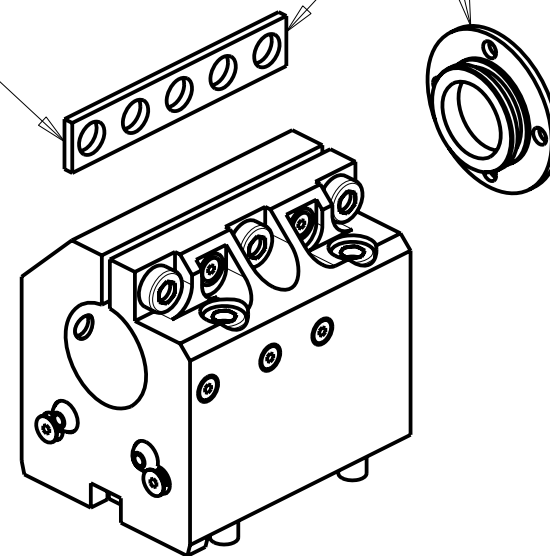

PER BOCCOLE DI RIDUZIONE VEDI PAG. TBL150-1-00  
 FOR REDUCING BUSHINGS SEE PAGE TBL150-1-00  
 FÜR REDUZIERBUCHSE SIEHE SEITE TBL150-1-00

Cod. MT	N°Utensili N°Tools N°Werkzeuge	Reversibile lato mandrino/contromandrino Reversible sub/main spindle side Umkehrbare Spindel-seite/ Gegenspindel-seite	Lubrificazione int. opzionale Coolant through optional Innenkuhlung Optional	Lubrificazione est. Ext. coolant Aussenkuhlung	Misure Dimensions Masse	D
0814000	1	X	X	X	mm	40
0813810	1	X	X	X	Inch	1 1/2"

### DOOSAN BMT 55

MOD: PUMA 230-240M/MS-280LM - PUMA 1500-2000-2500M/MS/Y/SY - LINX 300 M - PUMA 2100 SERIE  
 PUMA TT1500-TT1800MS/SY - TL2000-2500 (M) - PUMA GT2100 M

PORTAUTENSILE ASSIALE PER BARENO Ø40mm / Ø1 1/2" H=60mm

Axial single boring bar holder Ø40mm / Ø1 1/2" H=60mm

Axial Bohrhälter Ø40mm / Ø1 1/2" H=60mm

### M.T. srl

Via Casino Albini 480  
 Tel. 0541/956034-957884  
 Fax 0541/956341  
 47842 S. GIOVANNI IN M. (RN)  
 e-mail: mtma@mtmarchetti.com  
 http://www.mtmarchetti.com

PRODUZIONE MODULI ROTANTI



PAGINA DW 0630-2-20



PER BOCCOLE DI RIDUZIONE VEDI PAG. TBL150-1-00  
 FOR REDUCING BUSHINGS SEE PAGE TBL150-1-00  
 FÜR REDUZIERBUCHSE SIEHE SEITE TBL150-1-00

KIT ADDUZIONE INTERNA (OPZIONALE)  
 KIT FOR INTERNAL COOLANT (OPTIONAL)  
 KIT FUER INTERNE KUEHLMITTELZUFUHR (OPTIONAL)  
 Ø40 cod. KIT1000003  
 Ø1 1/2" cod. KIT1000004

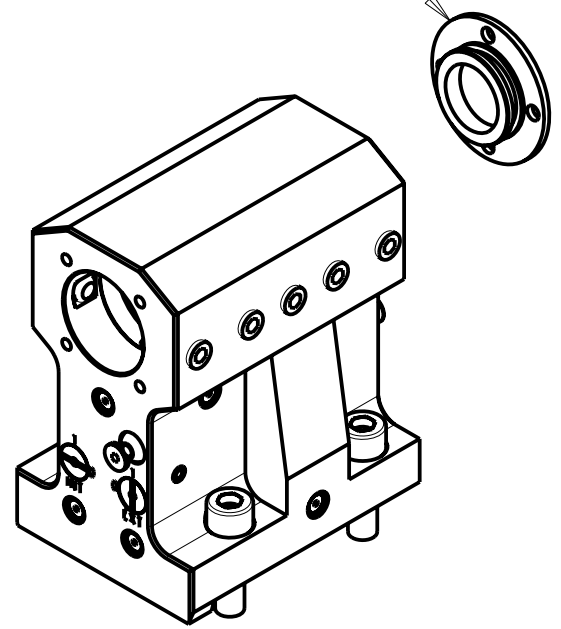
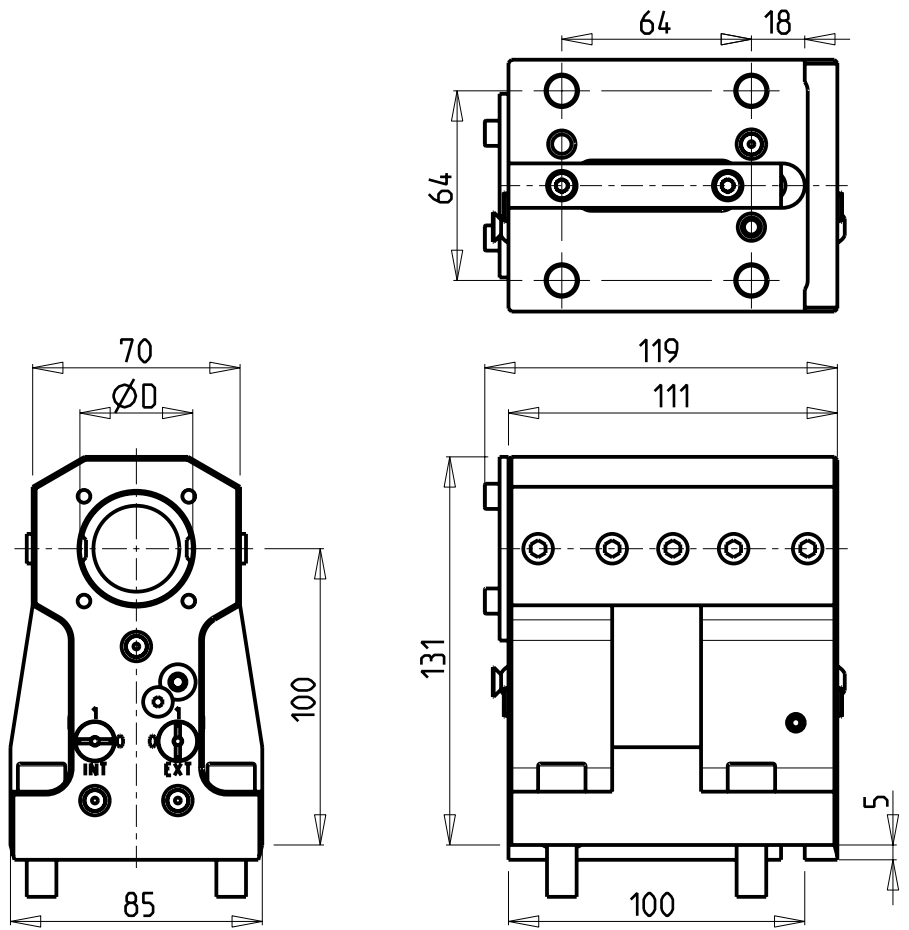

Cod. MT	N°Utensili N° Tools N° Werkzeuge	Reversibile lato mandrino/contromandrino Reversible sub/main spindle side Umkehrbare Spindelseite/ Gegenspindelseite	Lubrificazione int. opzionale Coolant through optional Innenkuehlung Optional	Lubrificazione est. Ext. coolant Aussenkuehlung	Misure Dimensions Masse	D
DW 00394000	1	X	X	X	mm	40
DW 00393810	1	X	X	X	Inch	1 1/2"

DOOSAN BMT 55  
 MOD: PUMA 230-240M/MS-280LM - PUMA 1500-2000-2500M/MS/Y/SY - PUMA 2100 SERIE - PUMA TT1500-TT1800MS/SY  
 PUMA TL2000-2500 (M) - MX1600/2100TS

PORTAUTENSILE ASSIALE PER BARENO Ø40mm / Ø1 1/2" H=100mm  
 Axial single boring bar holder Ø40mm / Ø1 1/2" H=100mm  
 Axial Bohrhälter Ø40mm / Ø1 1/2" H=100mm

**M.T. srl**  
 Via Casino Albini 480  
 Tel. 0541/956034-957884  
 Fax 0541/956341  
 47842 S. GIOVANNI IN M. (RN)  
 e-mail: mtma@mtmarchetti.com  
 http://www.mtmarchetti.com

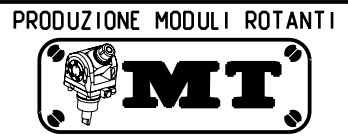

PAGINA DW 0640-2-10

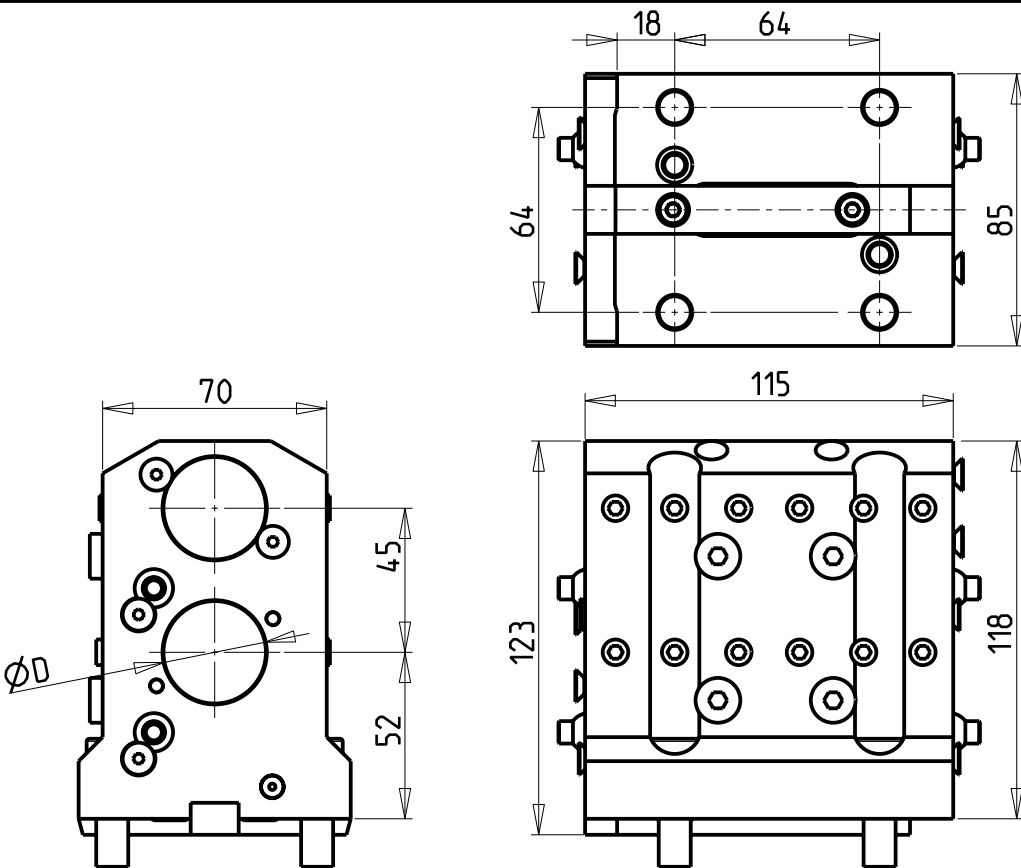

KIT ADDUZIONE INTERNA (OPZIONALE)  
 KIT FOR INTERNAL COOLANT (OPTIONAL)  
 KIT FUER INTERNE KUEHLMITTELZUFUHR (OPTIONAL)  
 Ø25-1" cod. KIT1000006  
 Ø32-1 1/4" cod. KIT1000001

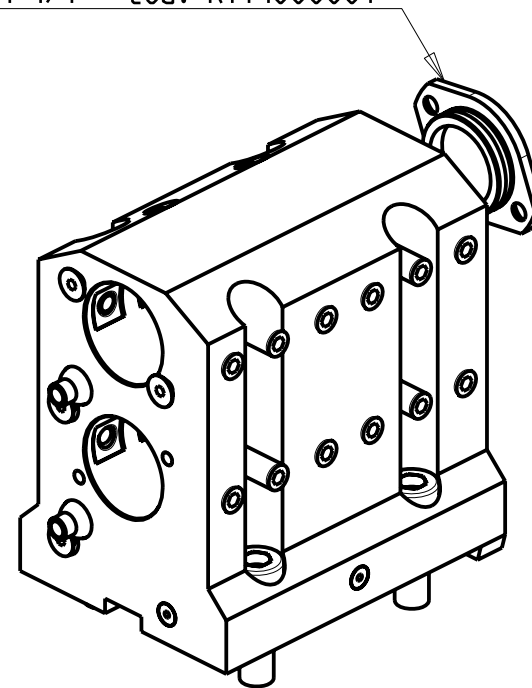

Cod. MT	N°Utensili N°Tools N°Werkzeuge	Reversibile lato mandrino/contromandrino Reversible sub/main spindle side Umkehrbare Spindelseite/ Gegenspindelseite	Lubrificazione int. opzionale Coolant through optional Innenkuhlung Optional	Lubrificazione est. Ext. coolant Aussehenkuhlung	Misure Dimensions Masse	D
DW 00092500	2	X	X	X	mm	25
DW 00092540	2	X	X	X	Inch	1"
DW 00093175	2	X	X	X	Inch	1 1/4"
DW 00093200	2	X	X	X	mm	32

PER BOCCOLE DI RIDUZIONE VEDI PAG. TBL150-1-00  
 FOR REDUCING BUSHINGS SEE PAGE TBL150-1-00  
 FÜR REDUZIERBUCHSE SIEHE SEITE TBL150-1-00

## DOOSAN BMT 55

MOD: PUMA 230-240M/MS-280LM - PUMA 1500-2000-2500M/MS/Y/SY - LINX 300 M - PUMA 2100 SERIE  
 PUMA TT1500-TT1800MS/SY - TL2000-2500 (M)

PORTAUTENSILE ASSIALE PER BARENO 2 POSIZIONI Ø25mm / Ø1" / Ø1 1/4" / Ø32mm

Axial double boring bar holder Ø25mm / Ø1" / Ø1 1/4" / Ø32mm

Axial Bohrhälter 2 Positionen Ø25mm / Ø1" / Ø1 1/4" / Ø32mm

**M.T. srl**

Via Casino Albini 480  
 Tel. 0541/956034-957884  
 Fax 0541/956341  
 47842 S. GIOVANNI IN M. (RN)  
 e-mail: mtma@mtmarchetti.com  
 http://www.mtmarchetti.com

PRODUZIONE MODULI ROTANTI



PAGINA DW 0862-2-00

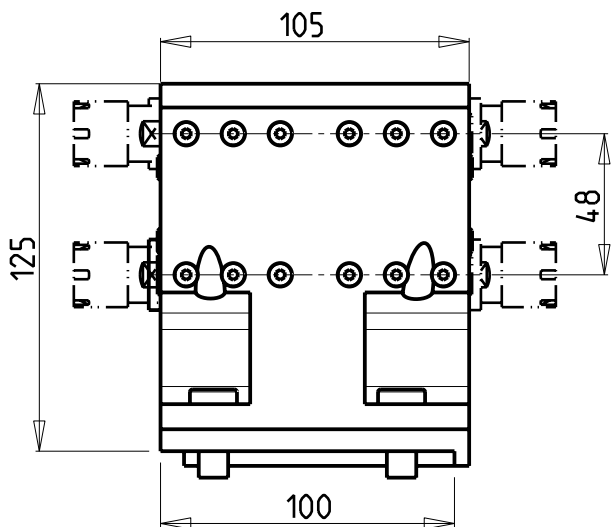
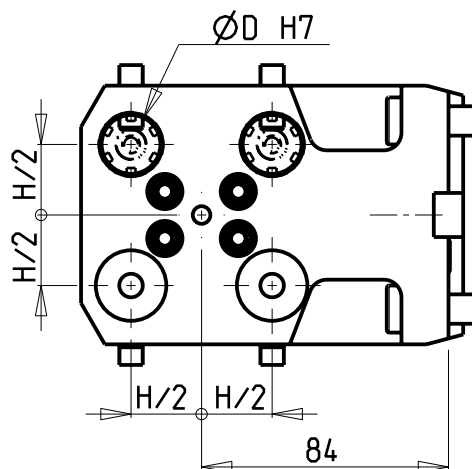
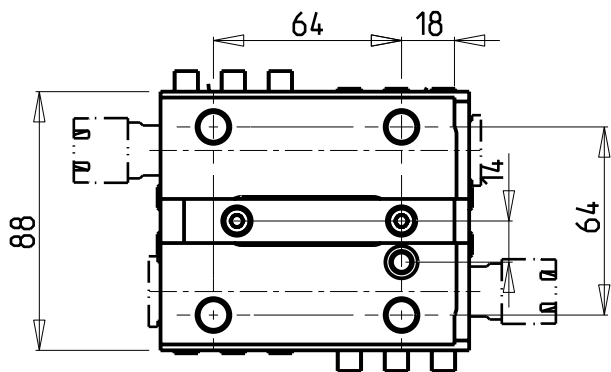

### DOTAZIONI - SUPPLIED WITH - AUSSTATTUNG

mm	N*5 Boccole - Bushings - Buchsen Ø16-12-10-8-6 N*1 ER16 Portapinza - Collet holder - Zangenhalter N*1 ER25 Portapinza - Collet holder - Zangenhalter
inch	N*3 Boccole - Bushings - Buchsen Ø1/2"-3/8"-1/4" N*1 ER16 Portapinza - Collet holder - Zangenhalter N*1 ER25 Portapinza - Collet holder - Zangenhalter

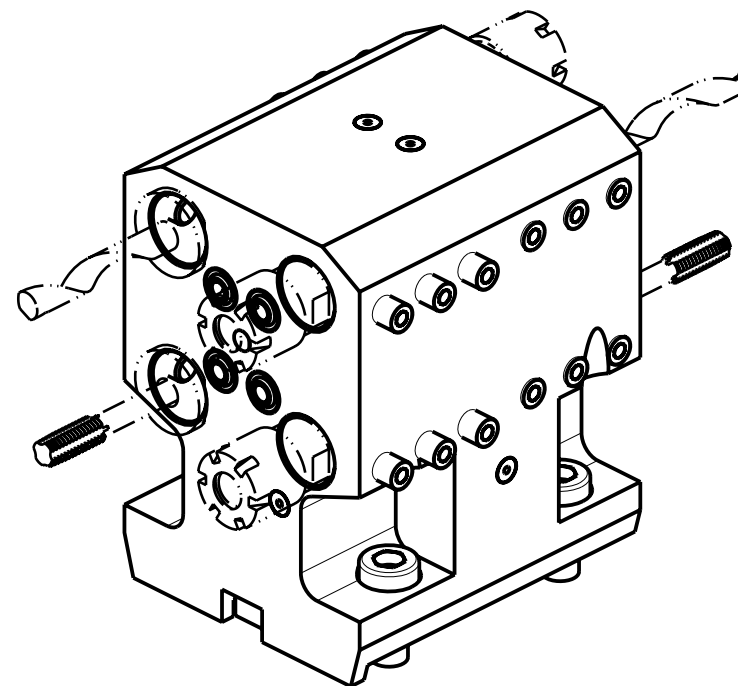

Cod. MT	N°Utensili N°Tools N°Werkzeuge	Lubrificazione est. Ext. coolant Aussehenkuehlung	Reversibile lato mandrino/contromandrino Reversible sub/main spindle side Umkehrbare Spindel-seite/ Gegenspindel-seite	Misure Dimensions Masse	D	H
0782000	4+4	X	X	mm	20	48
0781905	4+4	X	X	Inch	3/4"	1 7/8"

### DOOSAN BMT 55

MOD: PUMA 230-240M/MS-280LM - PUMA 1500-2000-2500M/MS/Y/SY - PUMA 2100 SERIE  
PUMA TT1500-TT1800MS/SY - TL2000-2500 (M)

PORTAUTENSILE ASSIALE PER BARENO 4+4 POSIZIONI Ø20mm / Ø3/4"

Axial 4+4 position boring bar holder Ø20mm / Ø3/4"

Axial Bohrhälter 4+4 Positionen Ø20mm / Ø3/4"

### M.T. srl

Via Casino Albini 480  
Tel. 0541/956034-957884  
Fax 0541/956341  
47842 S. GIOVANNI IN M. (RN)  
e-mail: mtma@mtmarchetti.com  
http://www.mtmarchetti.com

PRODUZIONE MODULI ROTANTI



PAGINA DW0924-2-00

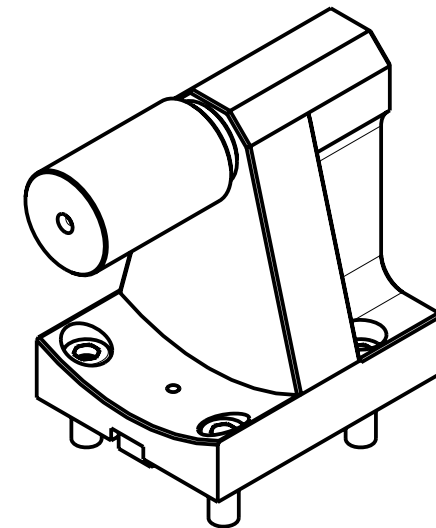
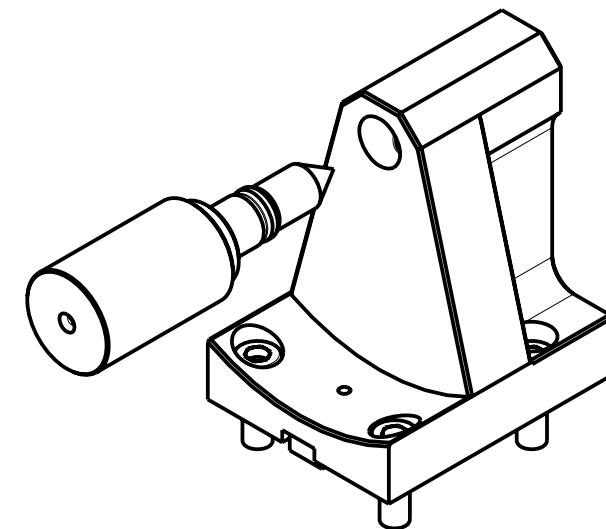
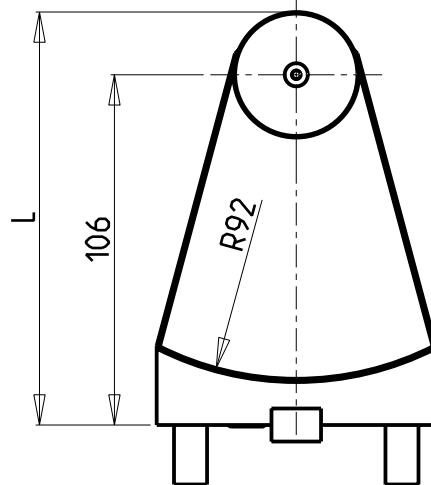
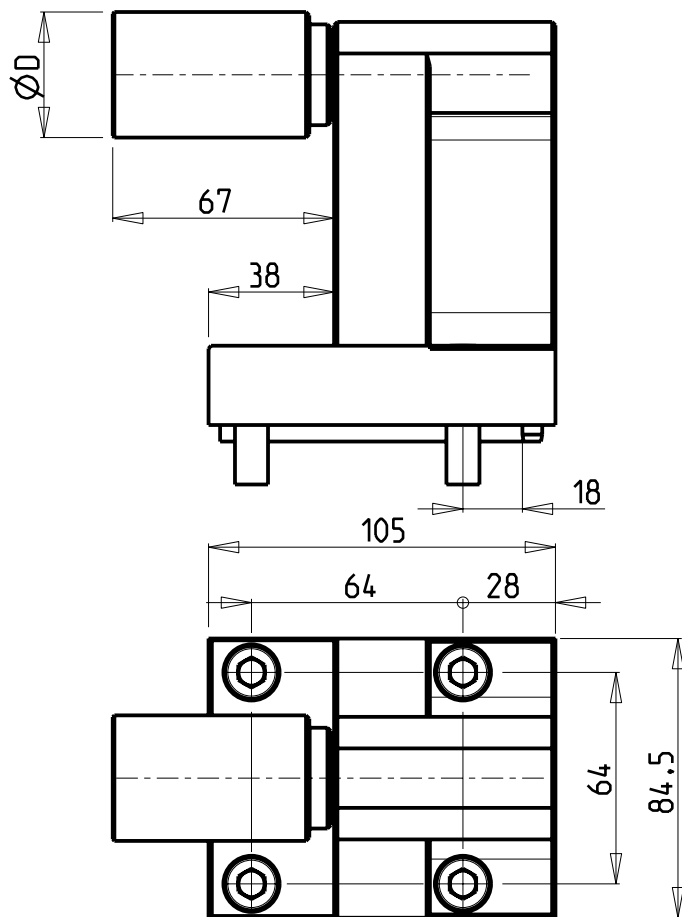

**ATTENZIONE - ATTENTION - ACHTUNG**

- cod. 0820100L : FUORI VOLTEGGIO!
- cod. 0820100L : OUT OF MAXIMUM SWING!
- cod. 0820100L : WERKZEUG AUSSER INTERFERENZ!

Cod. MT	N°Utensili N°Tools N°Werkzeuge	D	L
0820100	1	38	125
0820100L	1	2"	131.4

**DOOSAN BMT 55**

MOD: PUMA 230-240M/MS-280LM - PUMA 1500-2000-2500M/MS/Y/SY - LINX 300 M - PUMA 2100 SERIE  
PUMA TT1500-TT1800MS/SY - PUMA TL2000-2500 (M) - MX1600/2100TS

CONTROPUNTA PER CONTROMANDRINO

Tailstock for subspindle

Gegenspitz fuer Gegenspindel

**M.T. srl**

Via Casino Albini 480  
Tel. 0541/956034-957884  
Fax 0541/956341  
47842 S. GIOVANNI IN M. (RN)  
e-mail: mtma@mtmarchetti.com  
http://www.mtmarchetti.com

PRODUZIONE MODULI ROTANTI



PAGINA DW 0950-2-00

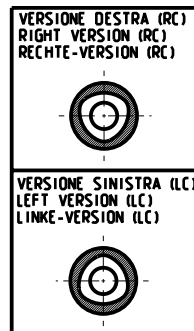
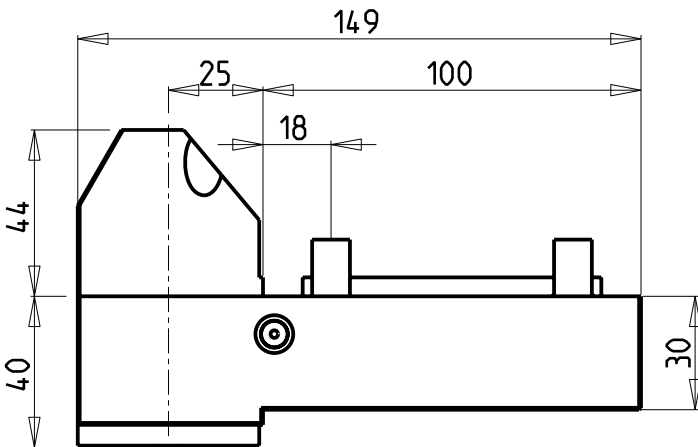
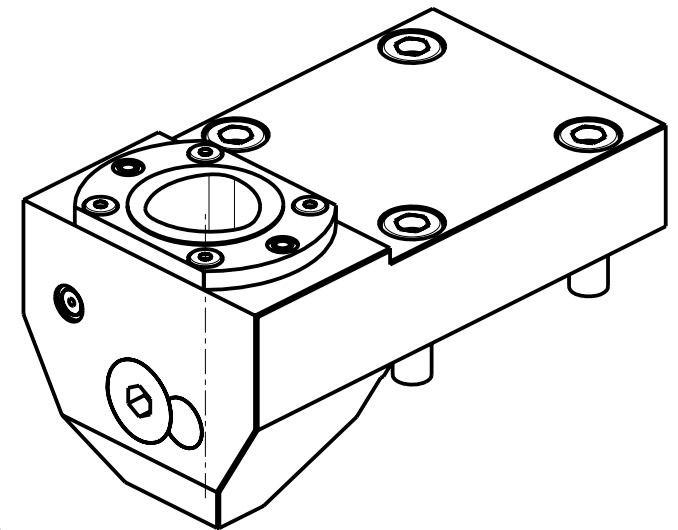
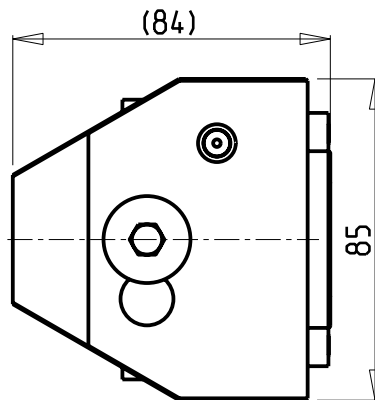
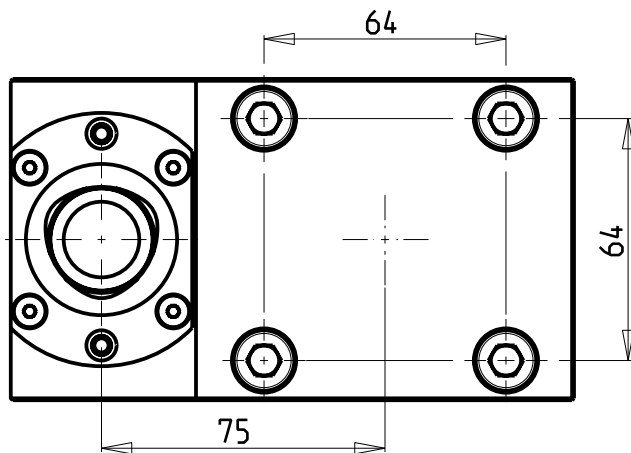

PER ORDINARE LA VERSIONE SX  
AGGIUNGERE "LC" AL CODICE IN TABELLA.  
ES: MNL0464010 DIVENTA MNL0464010LC

TO ORDER LEFT VERSION  
ADD A "LC" IN THE CODE-CHARTS.  
EXAMPLE: MNL0464010 BECOMES MNL0464010LC

UM DIE LINKE-VERSION ZU BESTELLEN, BEI DER  
ARTIKELBEZEICHNUNG "LC" HINZUFUEGEN.  
BEISPIEL: MNL0464010 WIRD DANN MNL0464010LC

Cod. MT	N°Utensili N°Tools N°Werkzeuge	Lubrificazione int. Coolant through Innenkuehlung	Reversibile lato mandrino/contromandrino Reversible sub/main spindle side Umkehrbare Spindelseite/ Gegenspindelseite	TAGLIA Size Masse
DW 00444010	1	X	X	C4

DOOSAN BMT 55

MOD: PUMA 230-240M/MS-280LM - PUMA 1500-2000-2500M/MS/Y/SY - PUMA 2100 SERIE - PUMA TT1500-TT1800MS/SY  
PUMA TL2000-2500 (M) - MX1600/2100TS - PUMA GT2100 M

PORTAUTENSILE RADIALE SINGOLO ARRETRATO COROMANT CAPTO®

Single rear-set radial static tool COROMANT CAPTO®

Radial Single-Werkzeughalter zurueckversetzt COROMANT CAPTO®

**M.T. srl**

Via Casino Albini 480  
Tel. 0541/956034-957884  
Fax 0541/956341

47842 S. GIOVANNI IN M. (RN)  
e-mail: mtma@mtmarchetti.com  
http://www.mtmarchetti.com

PRODUZIONE MODULI ROTANTI



PAGINA DW 0430-B-40

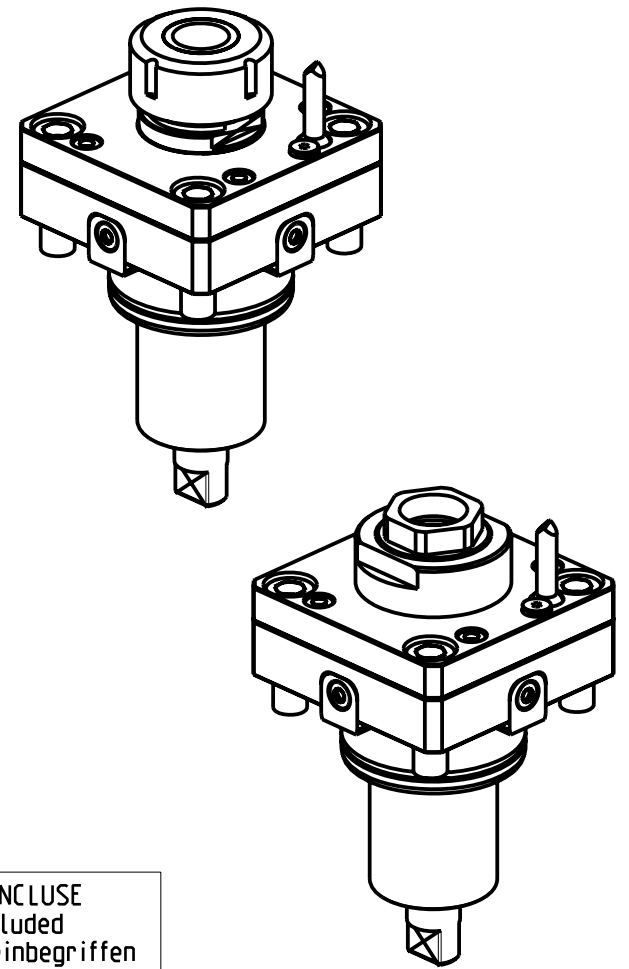
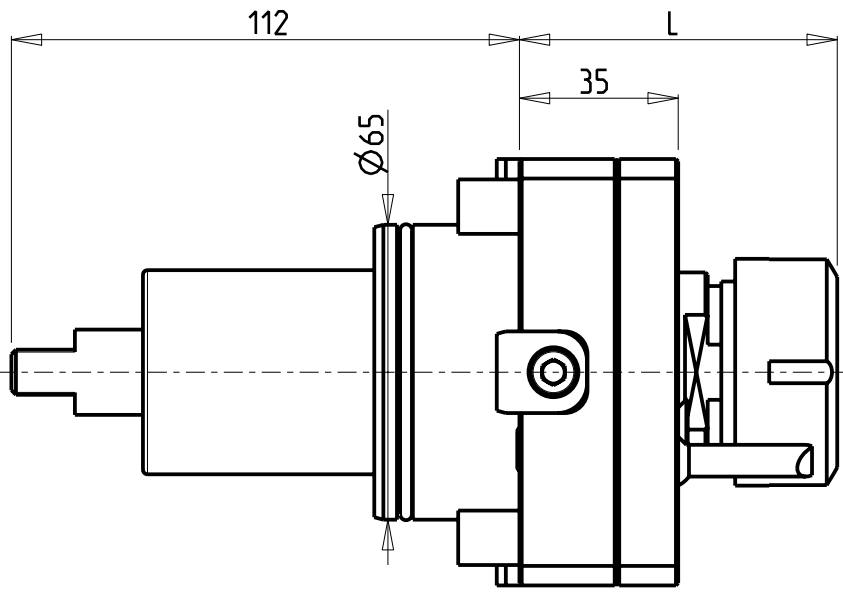
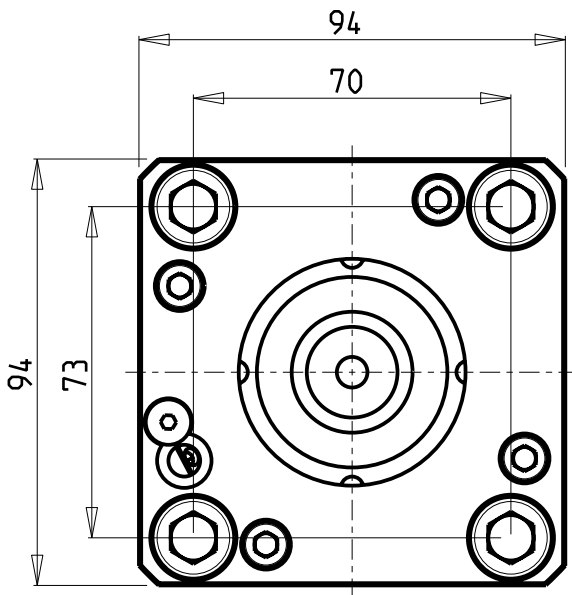

Cod. MT	Cod. EPPINGER	Mandrino Spindel Spindel	I	RPM	Coppia Max Max Torque Max Drehmoment	Lubrificazione int. Coolant through Innenkuehlung	Lubrificazione est. Ext. coolant Aussenkuehlung	L	CHIAVI NON INCLUSE Keys not included Schluessel nicht einbegriffen	
0281532	7.070.636	ER32	1:1	6000	70Nm		X	70.06	CHSTER32	CHUB36 o 0280018
0281032	-	ER32	1:1	6000	70Nm	P=30bar		70.06	CHSTER32	CHUB36 o 0280018
0280132	-	ER A 32	1:1	6000	70Nm		X	64.26	CHUB32	CHUB36 o 0280018
0280232	-	ER A 32	1:1	6000	70Nm	P=30bar		70.53	CHUB32	CHUB36 o 0280018

**DOOSAN BMT 65**

MOD: PUMA 300M/MS - V400M - TT2000SY-TT2500SY-TT2500MS - PUMA 2600/3100 SERIE  
 MX2000ST - MX2500LT/ST/LST - MX2600T-ST - VT 450M/TM - PUMA INVERTURN 3000M

MODULO MOTORIZZATO RADIALE  
 Radial driven tool  
 Radial angetriebenes Werkzeug

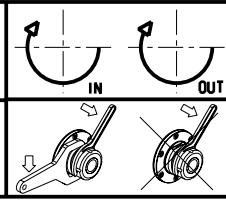

**M.T. srl**  
 Via Casino Albini 480  
 Tel. 0541/956034-957884  
 Fax 0541/956341  
 47842 S. GIOVANNI IN M. (RN)  
 e-mail: mtma@mtmarchetti.com  
 http://www.mtmarchetti.com

PRODUZIONE MODULI ROTANTI

PAGINA DW 0010-3-00

## CUSCINETTI MAGGIORATI PER LAVORAZIONI PESANTI

Reinforced bearings for  
heavy machining

Vergroesserte Lager fuer  
schwerere Bearbeitungen

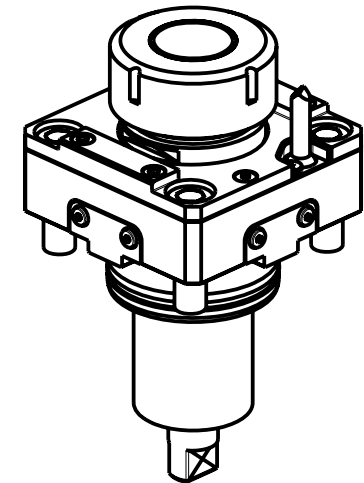
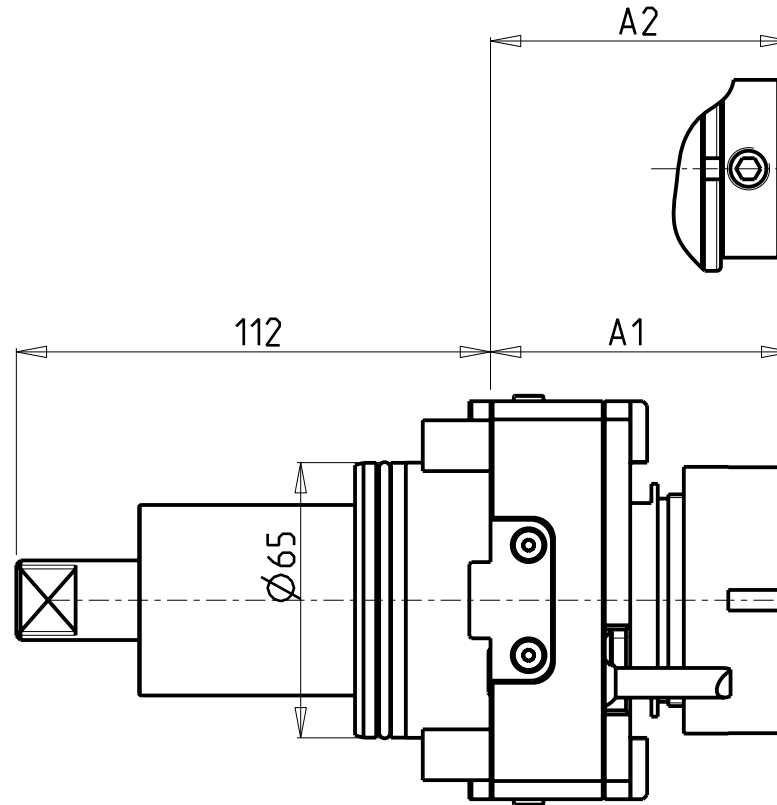
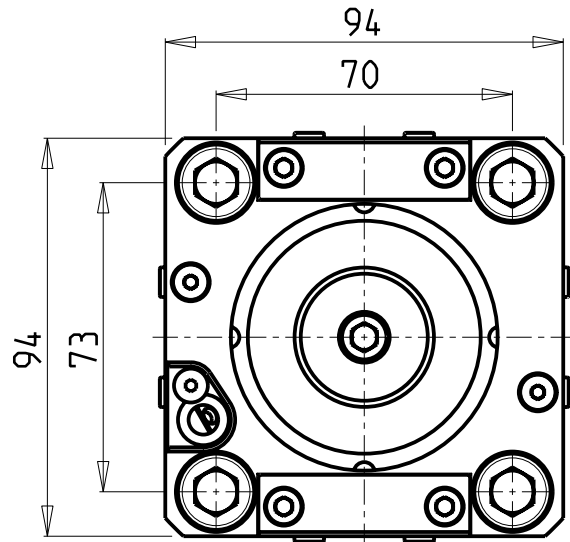

Cod. MT	Mandrino Spindel Spindel	I	RPM	Coppia Max Max Torque Max Drehmoment	Lubrificazione int. Coolant through Innenkuehlung	Lubrificazione est. Ext. coolant Aussenkuehlung	A1	A2	CHIAVI NON INCLUSE Keys not included Schluessel nicht einbegriffen	
DW00640140	ER40	1:1	6000	70Nm		X	71.16		CHSTER40	OKU0650004 ▪
DW00640240	ER40	1:1	6000	70Nm	P=30bar	X	82.16		CHSTER40	OKU0650004 ▪
DW00640625	WELDON25	1:1	6000	70Nm	P=30bar	X		72.5	-	-

• Chiave inclusa

• Key included

• Schluessel inbegriffen

### DOOSAN BMT 65

MOD: PUMA 300M/MS - V400M - TT2000SY-TT2500SY-TT2500MS - PUMA 2600/3100 SERIE  
MX2000ST - MX2500LT/ST/LST - MX2600T-ST - VT 450M/TM - PUMA INVERTURN 3000M

MODULO MOTORIZZATO RADIALE MAGGIORATO

Radial reinforced driven tool

Radial angetriebenes Werkzeug vergroessert

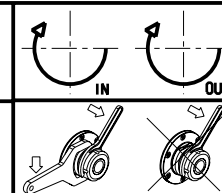

### M.T. srl

Via Casino Albini 480  
Tel. 0541/956034-957884

Fax 0541/956341

47842 S. GIOVANNI IN M. (RN)  
e-mail: mtma@mtmarchetti.com  
http://www.mtmarchetti.com

PRODUZIONE MODULI ROTANTI



PAGINA DW0020-3-00

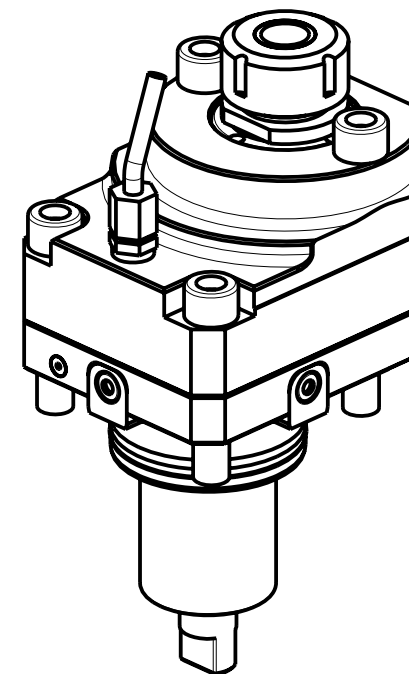
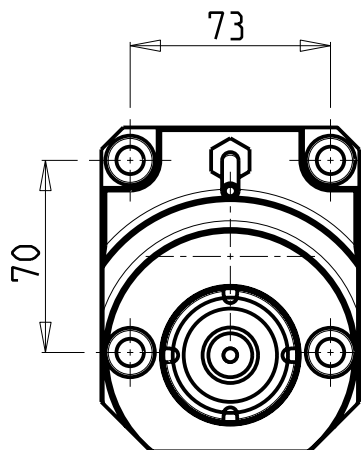
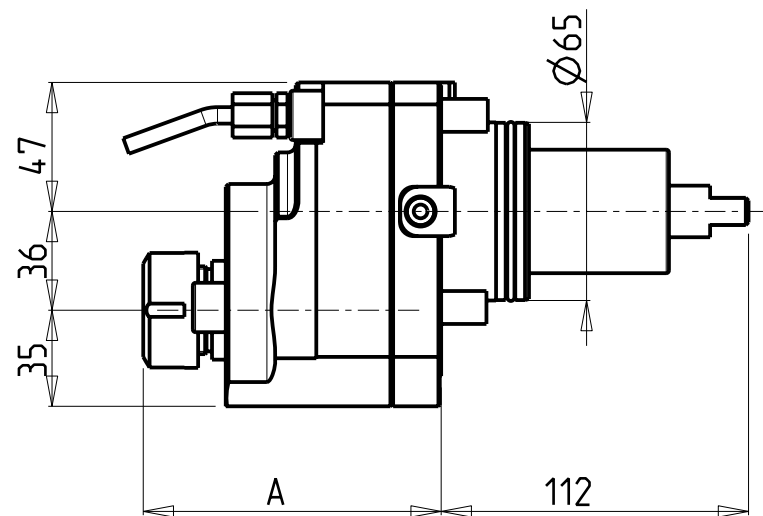
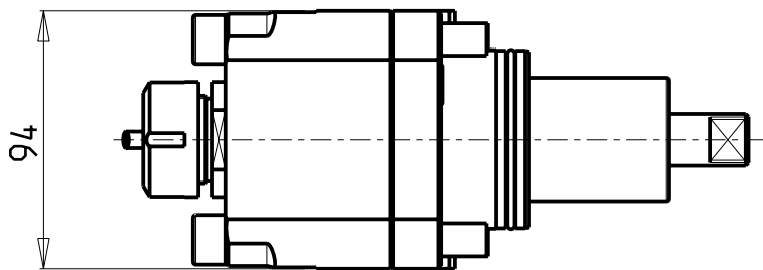

Cod. MT	Mandrino Spindle Spindel	I	RPM	Coppia Max Max Torque Max Drehmoment	Reversibile lato mandrino/contromandrino Reversible sub/main spindle side Umkehrbare Spindelseite/ Gegenspindelseite	Lubrificazione est. Ext. coolant Aussenkuehlung	A	CHIAVI NON INCLUSE Keys not included Schlüssel nicht einbegriffen
DW00140125	ER25	1:2	12000	30Nm	X	X	108.56	CHSTER25 MNL0210007

### DOOSAN BMT 65

MOD: PUMA 300M/MS - V400M - TT2000SY-TT2500SY-TT2500MS - PUMA 2600/3100 SERIE  
MX2000ST - MX2500LT/ST/LST - MX2600T-ST - VT 450M/TM - PUMA INVERTURN 3000M

MODULO MOTORIZZATO RADIALE MOLTIPLICATO I=1:2 DISASSATO IN Z 36mm

Radial geared-up I=1:2 driven tool re-directed in Z by 36mm

Radial angetriebenes Werkzeug uebersetzt I=1:2 achsversetzt in Z um 36mm

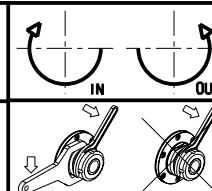

### M.T. srl

Via Casino Albini 480  
Tel. 0541/956034-957884  
Fax 0541/956341

47842 S. GIOVANNI IN M. (RN)  
e-mail: mtma@mtmarchetti.com  
http://www.mtmarchetti.com

PRODUZIONE MODULI ROTANTI



PAGINA DW 0030-3-30



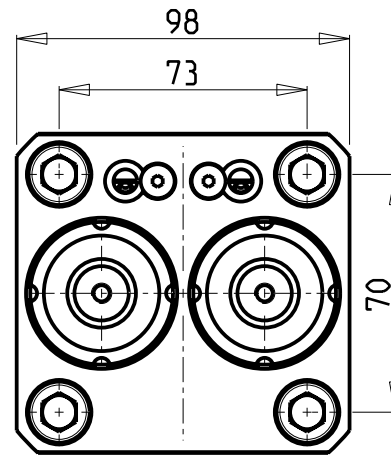
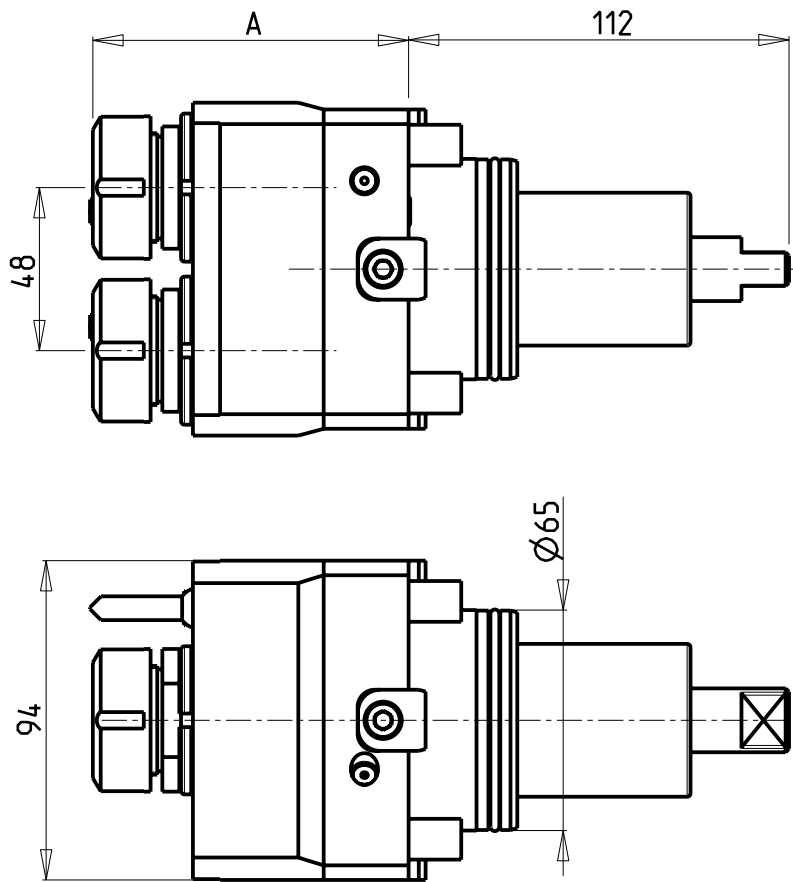

### ATTENZIONE - ATTENTION - ACHTUNG

- Per lo smontaggio degli utensili utilizzare sempre la chiave di contrasto come indicato nel manuale d'uso.
- For disassembly of the tools use always the contrast key as mentioned in the user instructions.
- Fuer das Abmontieren der Werkzeuge immer den Gegenschlüssel benutzen wie in der Bedienungsanleitung erwäohnt.

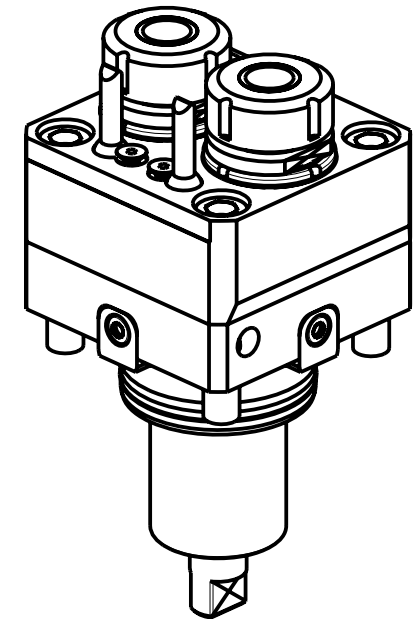

Cod. MT	Mandrino Spindle Spindel	I	RPM	Coppia Max Max Torque Max Drehmoment	Lubrificazione est. Ext. coolant Ausseukuehlung	A	CHIAVI NON INCLUDE Keys not included Schluessel nicht einbegriffen	
							CHMNER16	CHUB17
DW00540216	ER16	1:1	6000	30Nm	X	84.5	CHMNER16	CHUB17
DW00540225	ER25	1:1	6000	30Nm	X	85	CHSTER25	MNL0210007

## DOOSAN BMT 65

MOD: PUMA 300M/MS - V400M - TT2000SY-TT2500SY-TT2500MS - PUMA 2600/3100 SERIE  
VT 450M/TM - PUMA INVERTURN 3000M

MODULO MOTORIZZATO RADIALE 2 USCITE IN Y  
Radial single side twin head driven tool in Y  
Radial angetriebenes Werkzeug 2 Ausgaenge in Y

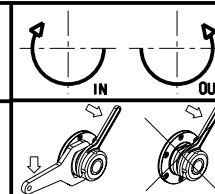

### M.T. srl

Via Casino Albini 480  
Tel. 0541/956034-957884  
Fax 0541/956341

47842 S. GIOVANNI IN M. (RN)  
e-mail: mtma@mtmarchetti.com  
http://www.mtmarchetti.com

PRODUZIONE MODULI ROTANTI



PAGINA DW 0080-3-00

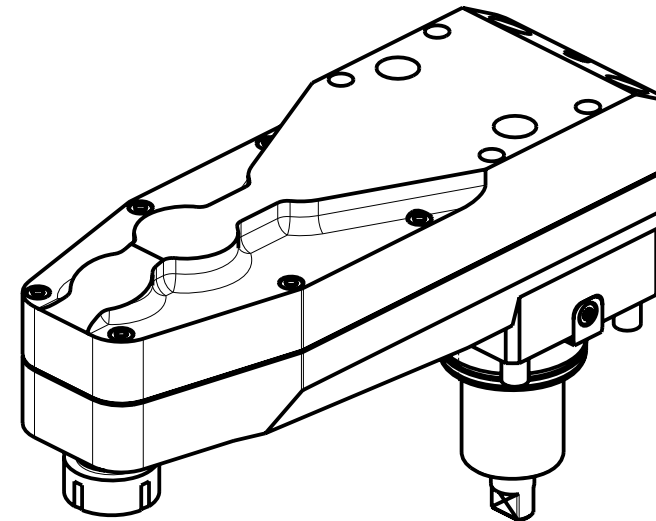
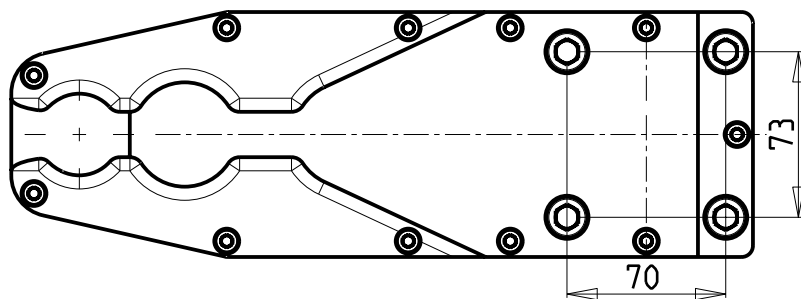
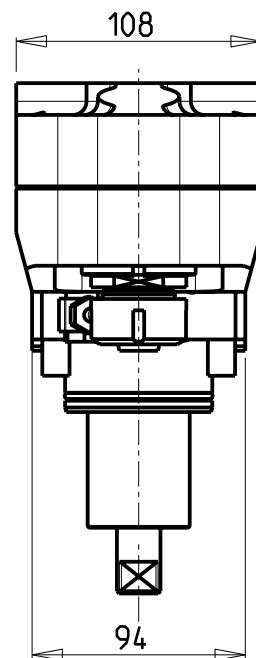
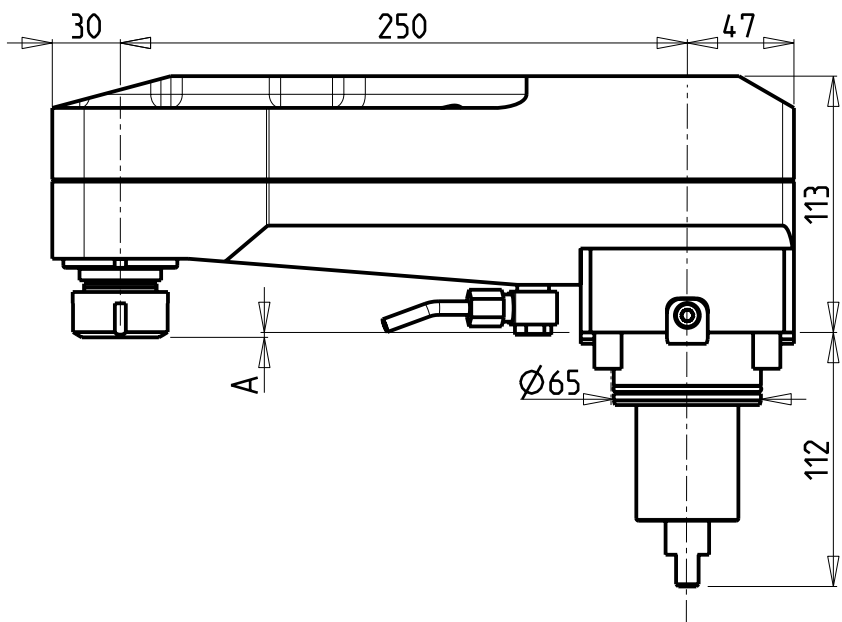

Cod. MT	Mandrino Spindle	I	RPM	Coppia Max Max Torque Max Drehmoment	Lubrificazione est. Ext. coolant Aussehenkuehlung	A	CHIAVI NON INCLUSE Keys not included Schlüssel nicht einbegriffen	
							CHSTER25	CHUB36
0700025	ER25	1:2	12000	30Nm	X	2.16	CHSTER25	CHUB36
0700032	ER32	1:2	12000	30Nm	X	14.66	CHSTER32	CHUB36

## DOOSAN BMT 65

MOD: PUMA 300M/MS - V400M - TT2000SY-TT2500SY-TT2500MS - PUMA 2600/3100 SERIE  
MX2000ST - MX2500LT/ST/LST - MX2600T-ST - VT 450M/TM - PUMA INVERTURN 3000M

MODULO MOTORIZZATO RADIALE ROVESCiato DISASSATO IN Z 250mm

Radial inverted driven tool re-directed in Z by 250mm

Radial angetriebenes Werkzeug ungekehrt achsversetzt in Z um 250mm

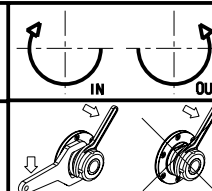

**M.T. srl**

Via Casino Albini 480  
Tel. 0541/956034-957884  
Fax 0541/956341

47842 S. GIOVANNI IN M. (RN)  
e-mail: mtma@mtmarchetti.com  
http://www.mtmarchetti.com

PRODUZIONE MODULI ROTANTI



PAGINA DW 0120-3-10

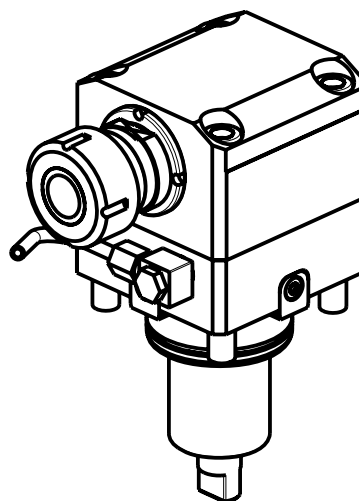
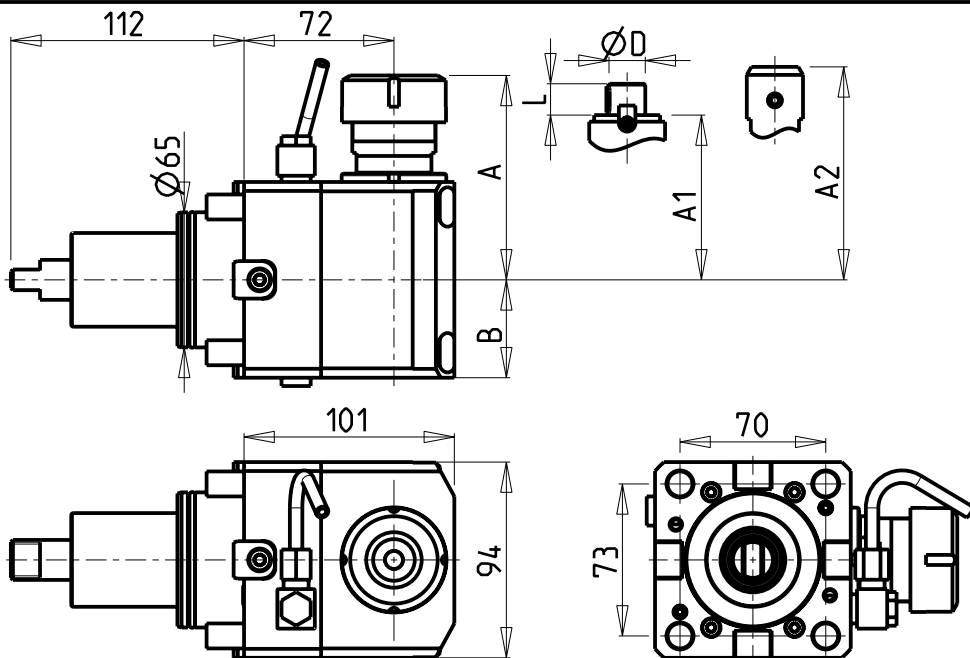

**ATTENZIONE - ATTENTION - ACHTUNG**

-Su macchine TT2000/2500SY-TT2500MS-MX2000ST-MX2500LT/ST/LST non arriva in centro mandrino  
 -On machines TT2000/2500SY-TT2500MS-MX2000ST-MX2500LT/ST/LST tool does not get to the centre of the spindle axis.  
 -Auf Maschinen TT2000/2500SY-TT2500MS-MX2000ST-MX2500LT/ST/LST erreicht das Werkzeug nicht die Mitte der Werkzeug-Achse.

**ATTENZIONE - ATTENTION - ACHTUNG**

- FINO AD ESAURIMENTO SCORTE  
 - clearance sale  
 - solange vorrat

- Chiave inclusa
- Key included
- Schlüssel inbegriffen

Cod. MT	Cod. EPPINGER	Mandrino Spindle Spindel	I	RPM	Coppia Max Max Torque Max Drehmoment	Reversibile lato mandrino/contromandrino Reversible sub/main spindle side Umkehrbare Spindel-seite/ Gegenspindel-seite	Lubr.interna Coolant through Innenkuehlung	Lubr.esterna Ext. coolant Aussenkuehlung	A	A1	A2	B	D	L	CHIAVI NON INCLUSE Keys not included Schlüssel nicht einbegriffen	
0321432	7.070.678	ER32	1:1	6000	50Nm	X	-	X	98.16	-	-	47	-	-	CHSTER32	CHUB36
0321032	-	ER32	1:1	6000	50Nm	X	P=18bar	X	98.16	-	-	79	-	-	CHSTER32	CHUB36
0320022	-	WELDON 20	1:1	6000	50Nm	X	-	X	-	-	100	47	-	-	-	-
0321617	-	Ø16x17	1:1	6000	50Nm	X	-	X	-	61	-	47	16	17	CH_VTCROCE_M08	CHUB36
0322219	-	Ø22x19	1:1	6000	50Nm	X	-	X	-	62	-	47	22	19	CH_VTCROCE_M10	CHUB36
0322240	-	Ø22x40	1:1	6000	50Nm	X	-	X	-	62	-	47	22	40	CH_VTCROCE_M10	CHUB36
0322721	-	Ø27x21	1:1	6000	50Nm	X	-	X	-	64	-	47	27	21	CH_VTCROCE_M12	CHUB36
0322733	-	Ø27x33	1:1	6000	50Nm	X	-	X	-	64	-	47	27	33	CH_VTCROCE_M12	CHUB36
0322750	-	Ø27x50	1:1	6000	50Nm	X	-	X	-	64	-	47	27	50	CH_VTCROCE_M12	CHUB36

**DOOSAN BMT 65**  
 MOD: PUMA 300M/MS - V400M - TT2000SY-TT2500SY-TT2500MS - PUMA 2600/3100 SERIE  
 MX2000ST - MX2500LT/ST/LST - VT 450M/TM - PUMA INVERTURN 3000M  
 MODULO MOTORIZZATO ASSIALE H=72mm  
 Axial driven tool H=72mm  
 Axial angetriebenes Werkzeug H=72mm

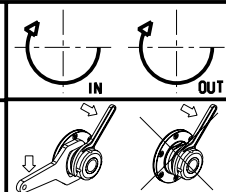

**M.T. srl**  
 Via Casino Albini 480  
 Tel. 0541/956034-957884  
 Fax 0541/956341  
 47842 S. GIOVANNI IN M. (RN)  
 e-mail: mtma@mtmarchetti.com  
 http://www.mtmarchetti.com

PRODUZIONE MODULI ROTANTI

PAGINA DW 0150-3-10

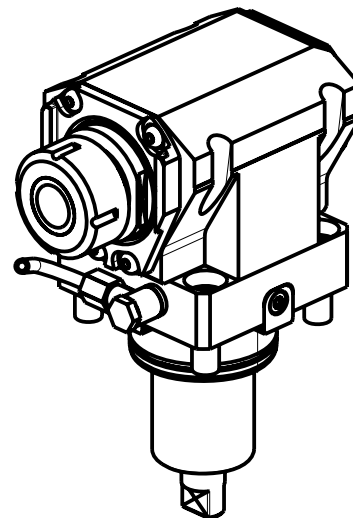
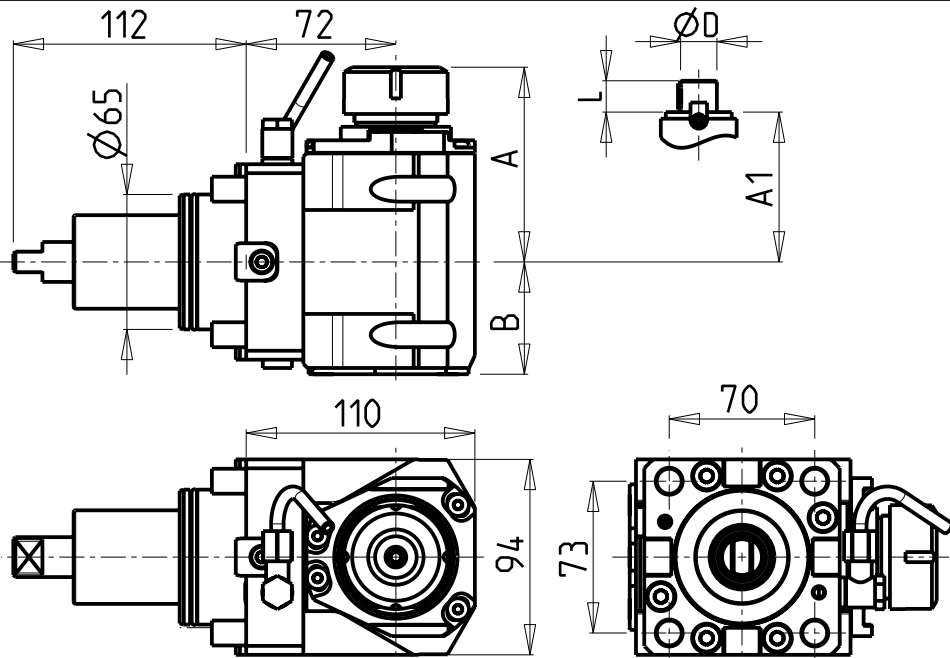

### ATTENZIONE - ATTENTION - ACHTUNG

-Su macchine TT2000/2500SY-TT2500MS-MX2000ST-MX2500LT/ST/LST non arriva in centro mandrino

-On machines TT2000/2500SY-TT2500MS-MX2000ST-MX2500LT/ST/LST tool does not get to the centre of the spindle axis.

-Auf Maschinen TT2000/2500SY-TT2500MS-MX2000ST-MX2500LT/ST/LST erreicht das Werkzeug nicht die Mitte der Werkzeug-Achse.

- Chiave inclusa
- Key included
- Schlüssel inbegriffen

Cod. MT	Mandrino Spindle Spindel	I	RPM	Coppia Max Max Torque Max Drehmoment	Reversibile lato mandrino/contromandrino Reversible sub/main spindle side Umkehrbare Spindel-seite/ Gegenspindel-seite	Lubr.interna Coolant through Innenkuehlung	Lubr.esterna Ext. coolant Aussenkuehlung	A	A1	B	D	L	CHIAVI NON INCLUSE Keys not included Schluessel nicht einbegriffen			
DW 00700125	ER25	1:1	6000	70Nm	X		X	91.16	-	54	-	-	CHSTER25	OKU0650004	▪	NEW
DW 00700225	ER25	1:1	6000	70Nm	X	P=70bar	X	91.16	-	65	-	-	CHSTER25	OKU0650004	▪	NEW
DW 00700132	ER32	1:1	6000	70Nm	X		X	93.66	-	54	-	-	CHSTER32	OKU0650004	▪	NEW
DW 00700232	ER32	1:1	6000	70Nm	X	P=70bar	X	93.66	-	65	-	-	CHSTER32	OKU0650004	▪	NEW
DW 00700140	ER40	1:1	6000	70Nm	X		X	98.16	-	54	-	-	CHSTER40	OKU0650004	▪	NEW
DW 00700240	ER40	1:1	6000	70Nm	X	P=70bar	X	98.16	-	65	-	-	CHSTER40	OKU0650004	▪	NEW
DW 00700516	Ø16x17	1:1	6000	70Nm	X		X	-	67.5	54	16	17	CH_VTCROCE_M08	OKU0650004	▪	NEW
DW 00700522	Ø22x19	1:1	6000	70Nm	X		X	-	67.5	54	22	19	CH_VTCROCE_M10	OKU0650004	▪	NEW
DW 00700527	Ø27x21	1:1	6000	70Nm	X		X	-	70	54	27	21	CH_VTCROCE_M12	OKU0650004	▪	NEW

### DOOSAN BMT 65

MOD: PUMA 300M/MS - V400M - TT2000SY-TT2500SY-TT2500MS - PUMA 2600/3100 SERIE MX2000ST - MX2500LT/ST/LST - VT 450M/TM - PUMA INVERTURN 3000M

MODULO MOTORIZZATO ASSIALE H=72mm

Axial driven tool H=72mm

Axial angetriebenes Werkzeug H=72mm

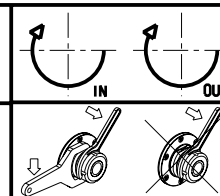

### M.T. srl

Via Casino Albini 480  
Tel. 0541/956034-957884  
Fax 0541/956341  
47842 S. GIOVANNI IN M. (RN)  
e-mail: mtma@mtmarchetti.com  
http://www.mtmarchetti.com

PRODUZIONE MODULI ROTANTI



PAGINA DW0150-3-11

ATTENZIONE - ATTENTION - ACHTUNG

-Su macchine TT2000/2500SY-TT2500MS-MX2000ST-MX2500LT/ST/LST non arriva in centro mandrino

-On machines TT2000/2500SY-TT2500MS-MX2000ST-MX2500LT/ST/LST tool does not get to the centre of the spindle axis.

-Auf Maschinen TT2000/2500SY-TT2500MS-MX2000ST-MX2500LT/ST/LST erreicht das Werkzeug nicht die Mitte der Werkzeug-Achse.

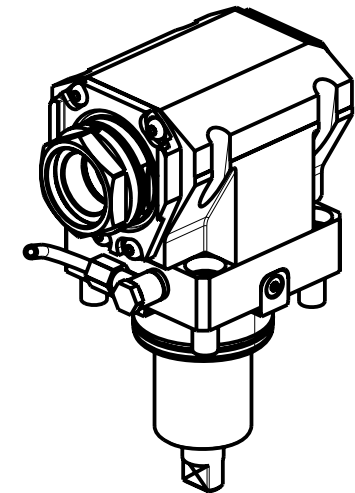
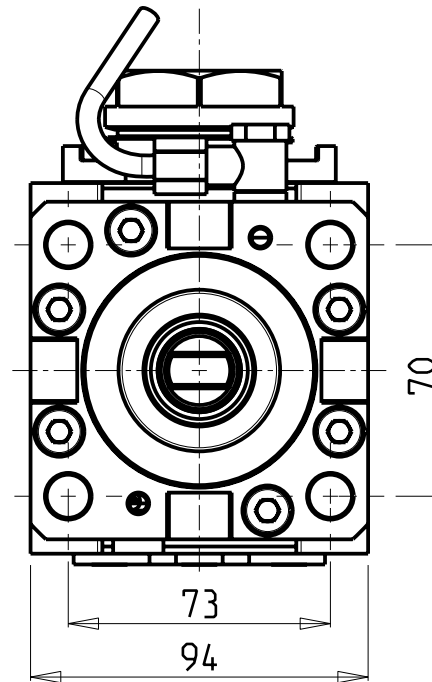
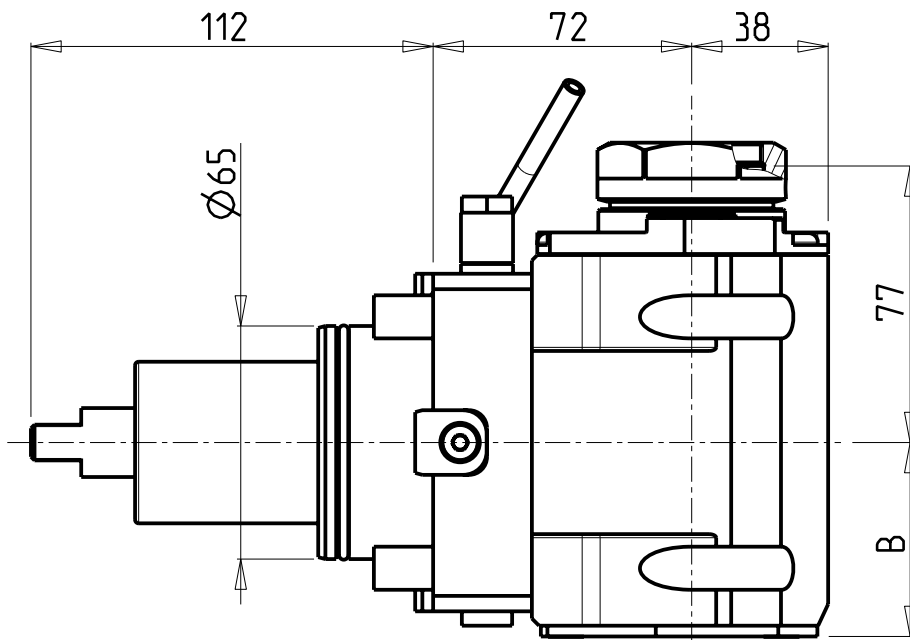

PER PORTAUTENSILI MODULARI MTSK-40 VEDI PAG. TBL300-1-40  
 FOR MTSK-40 QUICK CHANGE TOOLHOLDERS CLAMPINGS SEE PAGE TBL300-1-40  
 FUER MTSK-40 MODULARE WERKZEUGAUFNAHMEN SIEHE SEITE TBL300-1-40

Cod. MT	Mandrino Spindle Spindel	I	RPM	Coppia Max Max Torque Max Drehmoment	Reversibile lato mandrino/contromandrino Reversible sub/main spindle side Umkehrbare Spindel-seite/ Gegenspindel-seite	Lubr.interna Coolant through Innenkuehlung	Lubr.esterna Ext. coolant Ausseinkuehlung	B	CHIAVI NON INCLUSE Keys not included Schluessel nicht einbegriffen	
DW01170140	MTSK-40	1:1	6000	70Nm	X		X	54	CHUB46	OKU0650004 •
DW01170240	MTSK-40	1:1	6000	70Nm	X	P=70bar	X	65	CHUB46	OKU0650004 •

- Chiave inclusa
- Key included
- Schluessel inbegriffen

NEW  
NEW

DOOSAN BMT 65

MOD: PUMA 300M/MS - V400M - TT2000SY-TT2500SY-TT2500MS - PUMA 2600/3100 SERIE  
 MX2000ST - MX2500LT/ST/LST - VT 450M/TM - PUMA INVERTURN 3000M

MODULO MOTORIZZATO ASSIALE MTSK H=72mm

Axial MTSK driven tool H=72mm

Axial MTSK angetriebenes Werkzeug H=72mm

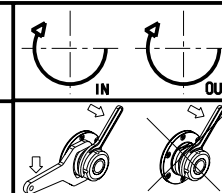

M.T. srl

Via Casino Albini 480  
 Tel. 0541/956034-957884

Fax 0541/956341

47842 S. GIOVANNI IN M. (RN)

e-mail: mtma@mtmarchetti.com

http://www.mtmarchetti.com

PRODUZIONE MODULI ROTANTI



PAGINA DW 0150-3-11-K

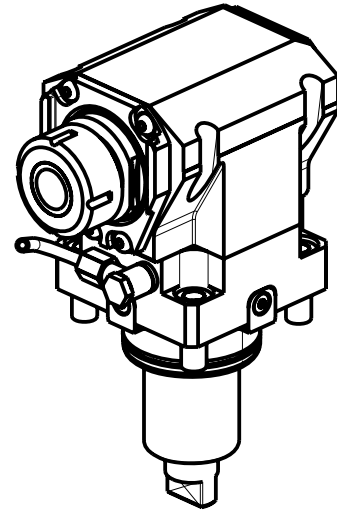
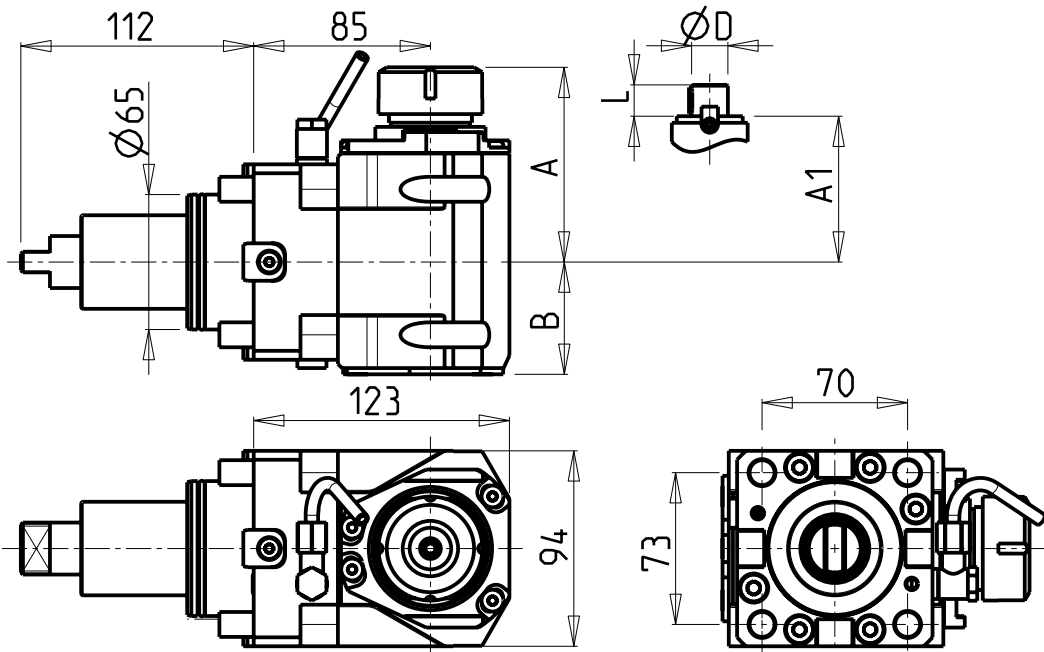

**ATTENZIONE - ATTENTION - ACHTUNG**

-Su macchine TT2000/2500SY-TT2500MS-MX2000ST-MX2500LT/ST/LST non arriva in centro mandrino  
 -On machines TT2000/2500SY-TT2500MS-MX2000ST-MX2500LT/ST/LST tool does not get to the centre of the spindle axis.  
 -Auf Maschinen TT2000/2500SY-TT2500MS-MX2000ST-MX2500LT/ST/LST erreicht das Werkzeug nicht die Mitte der Werkzeug-Achse.

- Chiave inclusa
- Key included
- Schlüssel inbegriffen

Cod. MT	Mandrino Spindle Spindel	I	RPM	Coppia Max Max Torque Max Drehmoment	Reversibile lato mandrino/contromandrino Reversible sub/main spindle side Umkehrbare Spindel-seite/ Gegenspindel-seite	Lubr.interna Coolant through Innenkuehlung	Lubr.esterna Ext. coolant Aussenkuehlung	A	A1	B	D	L	CHIAVI NON INCLUDE Keys not included Schluessel nicht einbegriffen		
DW 01130125	ER25	1:1	6000	70Nm	X		X	91.16	-	54	-	-	CHSTER25	OKU0650004	NEW
DW 01130225	ER25	1:1	6000	70Nm	X	P=70bar	X	91.16	-	65	-	-	CHSTER25	OKU0650004	NEW
DW 01130132	ER32	1:1	6000	70Nm	X		X	93.66	-	54	-	-	CHSTER32	OKU0650004	NEW
DW 01130232	ER32	1:1	6000	70Nm	X	P=70bar	X	93.66	-	65	-	-	CHSTER32	OKU0650004	NEW
DW 01130140	ER40	1:1	6000	70Nm	X		X	98.16	-	54	-	-	CHSTER40	OKU0650004	NEW
DW 01130240	ER40	1:1	6000	70Nm	X	P=70bar	X	98.16	-	65	-	-	CHSTER40	OKU0650004	NEW
DW 01130516	Ø16x17	1:1	6000	70Nm	X		X	-	67.5	54	16	17	CH_VTCROCE_M08	OKU0650004	NEW
DW 01130522	Ø22x19	1:1	6000	70Nm	X		X	-	67.5	54	22	19	CH_VTCROCE_M10	OKU0650004	NEW
DW 01130527	Ø27x21	1:1	6000	70Nm	X		X	-	70	54	27	21	CH_VTCROCE_M12	OKU0650004	NEW

**DOOSAN BMT 65**  
 MOD: PUMA 300M/MS - V400M - TT2000SY-TT2500SY-TT2500MS - PUMA 2600/3100 SERIE  
 MX2000ST - MX2500LT/ST/LST - VT 450M/TM - PUMA INVERTURN 3000M  
 MODULO MOTORIZZATO ASSIALE H=85mm  
 Axial driven tool H=85mm  
 Axial angetriebenes Werkzeug H=85mm

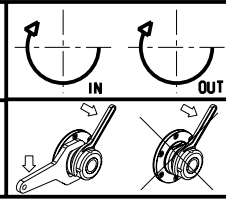

**M.T. srl**  
 Via Casino Albini 480  
 Tel. 0541/956034-957884  
 Fax 0541/956341  
 47842 S. GIOVANNI IN M. (RN)  
 e-mail: mtma@mtmarchetti.com  
 http://www.mtmarchetti.com

PRODUZIONE MODULI ROTANTI

PAGINA DW 0150-3-15

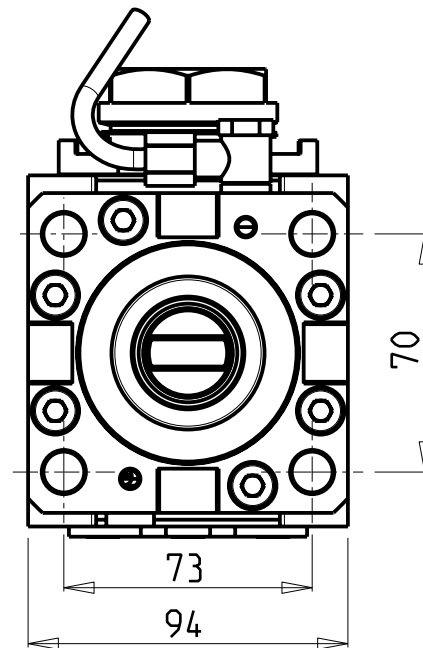
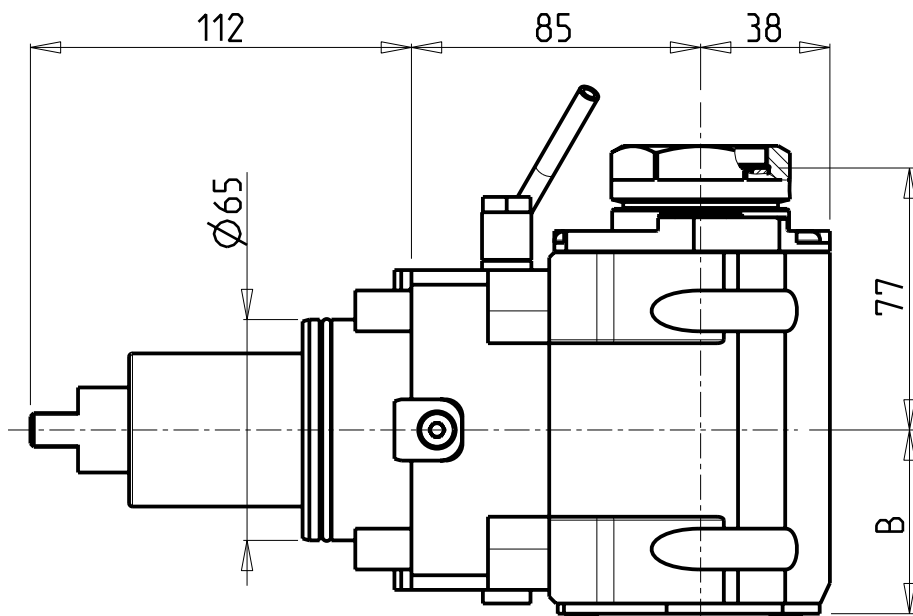

**ATTENZIONE - ATTENTION - ACHTUNG**

-Su macchine TT2000/2500SY-TT2500MS-MX2000ST-MX2500LT/ST/LST non arriva in centro mandrino

-On machines TT2000/2500SY-TT2500MS-MX2000ST-MX2500LT/ST/LST tool does not get to the centre of the spindle axis.

-Auf Maschinen TT2000/2500SY-TT2500MS-MX2000ST-MX2500LT/ST/LST erreicht das Werkzeug nicht die Mitte der Werkzeug-Achse.

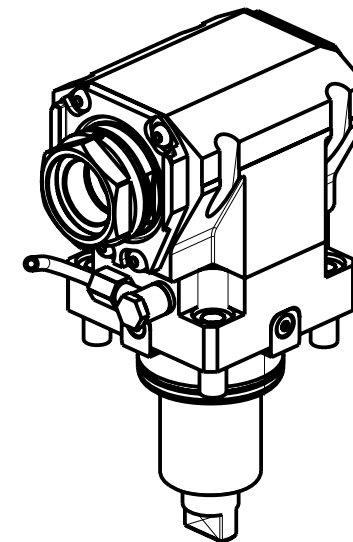

PER PORTAUTENSILI MODULARI MTSK-40 VEDI PAG. TBL300-1-40  
 FOR MTSK-40 QUICK CHANGE TOOLHOLDERS CLAMPINGS SEE PAGE TBL300-1-40  
 FUER MTSK-40 MODULARE WERKZEUGAUFNAHMEN SIEHE SEITE TBL300-1-40

Cod. MT	Mandrino Spindle Spindel	I	RPM	Coppia Max Max Torque Max Drehmoment	Reversibile lato mandrino/contromandrino Reversible sub/main spindle side Umkehrbare Spindel-seite/ Gegenspindel-seite	Lubr.interna Coolant through Innenkuehlung	Lubr.esterna Ext. coolant Aussenkuehlung	B	CHIAVI NON INCLUSE Keys not included Schluessel nicht einbegriffen	
DW01180140	MTSK-40	1:1	6000	70Nm	X		X	54	CHUB46	OKU0650004 •
DW01180240	MTSK-40	1:1	6000	70Nm	X	P=70bar	X	65	CHUB46	OKU0650004 •

- Chiave inclusa
- Key included
- Schluessel inbegriffen

NEW  
NEW

**DOOSAN BMT 65**

MOD: PUMA 300M/MS - V400M - TT2000SY-TT2500SY-TT2500MS - PUMA 2600/3100 SERIE  
 MX2000ST - MX2500LT/ST/LST - VT 450M/TM - PUMA INVERTURN 3000M

MODULO MOTORIZZATO ASSIALE MTSK H=85mm

Axial MTSK driven tool H=85mm

Axial MTSK angetriebenes Werkzeug H=85mm

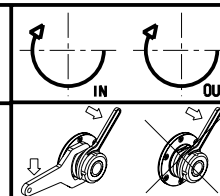

**M.T. srl**

Via Casino Albini 480  
 Tel. 0541/956034-957884

Fax 0541/956341

47842 S. GIOVANNI IN M. (RN)

e-mail: mtma@mtmarchetti.com

http://www.mtmarchetti.com

**PRODUZIONE MODULI ROTANTI**



PAGINA DW 0150-3-15-K

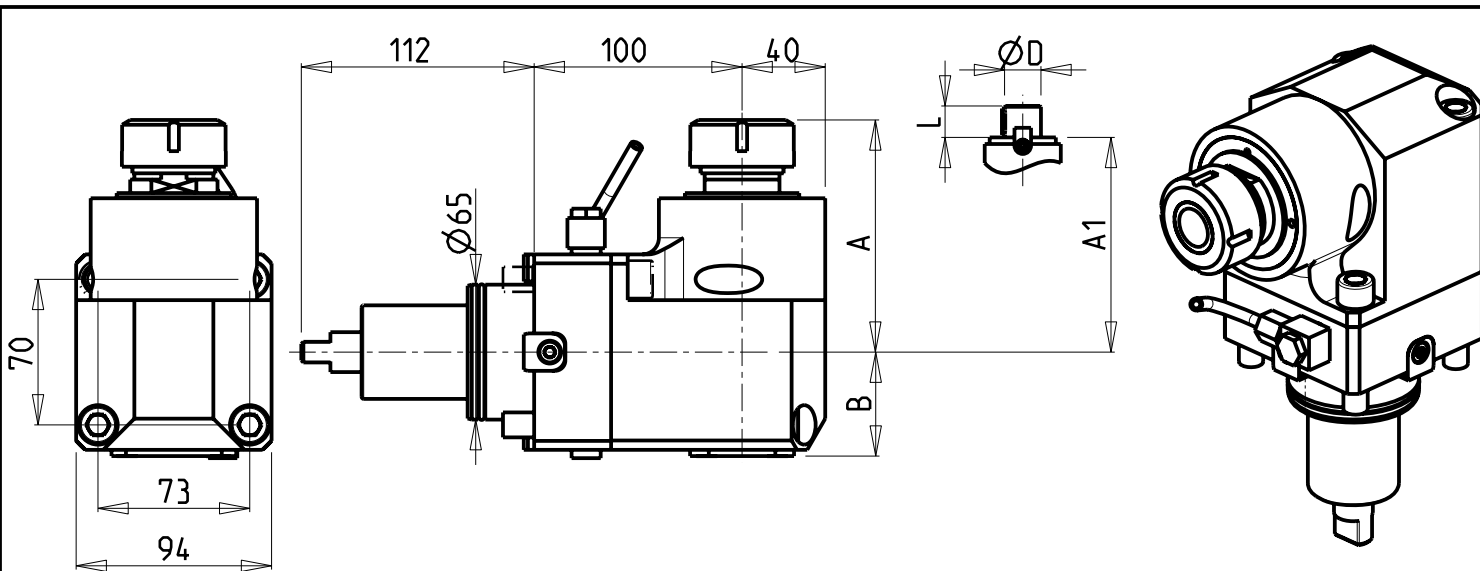

### ATTENZIONE - ATTENTION - ACHTUNG

- VERIFICARE LE MISURE DI INGOMBRO PER POSSIBILE INTERFERENZA SU ALCUNI MODELLI DI MACCHINE
- Please check the overall sizes for possible interferences on some machine models
- Bitte überprüfen sie das ausmass um mögliche interferenzen auf einigen maschinen modellen zu vermeiden

- Chiave inclusa
- Key included
- Schluessel inbegriffen

Cod. MT	Mandrino Spindle	I	RPM	Coppia Max Max Torque Max Drehmoment	Reversibile lato mandrino/contromandrino Reversible sub/main spindle side Umkehrbare Spindelseite/ Gegenspindelseite	Lubr.interna Coolant through Innenkuehlung	Lubr.esterna Ext. coolant Aussenkuehlung	A	A1	B	D	L	CHIAVI NON INCLUDE Keys not included Schluessel nicht einbegriffen	
0711432	ER32	1:1	6000	70Nm	X		X	111.56	-	47	-	-	CHSTER32	CHUB36
0711032	ER32	1:1	6000	70Nm	X	P=70bar	X	111.56	-	72	-	-	CHSTER32	CHUB36
0711532	ER A 32	1:1	6000	70Nm	X		X	102.03	-	47	-	-	CHUB50	CHUB32
0712640	ER40	1:1	6000	70Nm	X		X	115	-	47	-	-	CHSTER40	CHUB46
0712540	ER40	1:1	6000	70Nm	X	P=70bar	X	115	-	72	-	-	CHSTER40	CHUB46
0711617	Ø16x17	1:1	6000	70Nm	X		X	-	86	47	16	17	CH_VTCROCE_M08	CHUB36
0712219	Ø22x19	1:1	6000	70Nm	X		X	-	88	47	22	19	CH_VTCROCE_M10	CHUB36
0712240	Ø22x40	1:1	6000	70Nm	X		X	-	86	47	22	40	CH_VTCROCE_M10	CHUB36
0712721	Ø27x21	1:1	6000	70Nm	X		X	-	87.5	47	27	21	CH_VTCROCE_M12	CHUB36
0712733	Ø27x33	1:1	6000	70Nm	X		X	-	86	47	27	33	CH_VTCROCE_M12	CHUB36
0712750	Ø27x50	1:1	6000	70Nm	X		X	-	86	47	27	50	CH_VTCROCE_M12	CHUB36

NEW

### DOOSAN BMT 65

MOD: V400M - TT2000SY-TT2500SY-TT2500MS - PUMA 2600/3100 SERIE  
 MX2000ST - MX2500LT/ST/LST - MX2600T-ST - VT 450M/TM - PUMA INVERTURN 3000M

MODULO MOTORIZZATO ASSIALE H=100mm

Axial driven tool H=100mm

Axial angetriebenes Werkzeug H=100mm

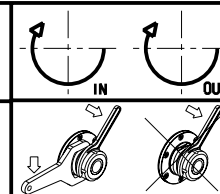

### M.T. srl

Via Casino Albini 480  
 Tel. 0541/956034-957884  
 Fax 0541/956341  
 47842 S. GIOVANNI IN M. (RN)  
 e-mail: mtma@mtmarchetti.com  
 http://www.mtmarchetti.com

PRODUZIONE MODULI ROTANTI



PAGINA DW 0150-3-20



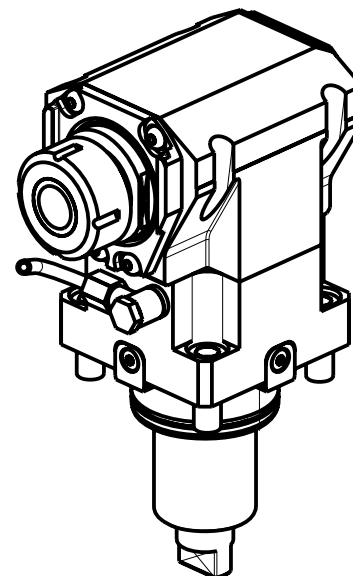
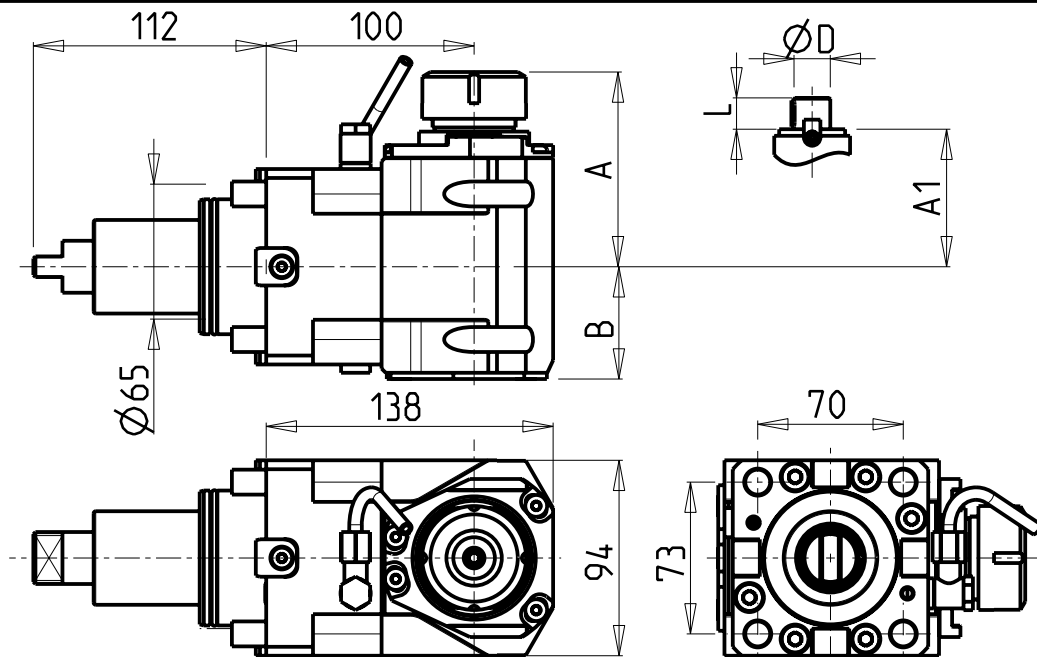

### ATTENZIONE - ATTENTION - ACHTUNG

- VERIFICARE LE MISURE DI INGOMBRO PER POSSIBILE INTERFERENZA SU ALCUNI MODELLI DI MACCHINE
- Please check the overall sizes for possible interferences on some machine models
- Bitte überprüfen sie das ausmass um mögliche interferenzen auf einigen maschinen modellen zu vermeiden

- Chiave inclusa
- Key included
- Schlüssel inbegriffen

Cod. MT	Mandrino Spindle Spindel	I	RPM	Coppia Max Max Torque Max Drehmoment	Reversibile lato mandrino/contromandrino Reversible sub/main spindle side Umkehrbare Spindel-seite/ Gegenspindel-seite	Lubr.interna Coolant through Innenkuehlung	Lubr.esterna Ext. coolant Aussenkuehlung	A	A1	B	D	L	CHIAVI NON INCLUSE Keys not included Schluessel nicht einbegriffen		
DW 01140125	ER25	1:1	6000	70Nm	X		X	91.16	-	54	-	-	CHSTER25	OKU0650004	NEW
DW 01140225	ER25	1:1	6000	70Nm	X	P=70bar	X	91.16	-	65	-	-	CHSTER25	OKU0650004	NEW
DW 01140132	ER32	1:1	6000	70Nm	X		X	93.66	-	54	-	-	CHSTER32	OKU0650004	NEW
DW 01140232	ER32	1:1	6000	70Nm	X	P=70bar	X	93.66	-	65	-	-	CHSTER32	OKU0650004	NEW
DW 01140140	ER40	1:1	6000	70Nm	X		X	98.16	-	54	-	-	CHSTER40	OKU0650004	NEW
DW 01140240	ER40	1:1	6000	70Nm	X	P=70bar	X	98.16	-	65	-	-	CHSTER40	OKU0650004	NEW
DW 01140516	Ø16x17	1:1	6000	70Nm	X		X	-	67.5	54	16	17	CH_VTCROCE_M08	OKU0650004	NEW
DW 01140522	Ø22x19	1:1	6000	70Nm	X		X	-	67.5	54	22	19	CH_VTCROCE_M10	OKU0650004	NEW
DW 01140527	Ø27x21	1:1	6000	70Nm	X		X	-	70	54	27	21	CH_VTCROCE_M12	OKU0650004	NEW

## DOOSAN BMT 65

MOD: PUMA 300M/MS - V400M - TT2000SY-TT2500SY-TT2500MS - PUMA 2600/3100 SERIE  
MX2000ST - MX2500LT/ST/LST - VT 450M/TM - PUMA INVERTURN 3000M

MODULO MOTORIZZATO ASSIALE H=100mm

Axial driven tool H=100mm

Axial angetriebenes Werkzeug H=100mm

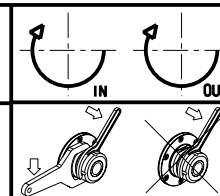

### M.T. srl

Via Casino Albini 480  
Tel. 0541/956034-957884

Fax 0541/956341

47842 S. GIOVANNI IN M. (RN)

e-mail: mtma@mtmarchetti.com

http://www.mtmarchetti.com

PRODUZIONE MODULI ROTANTI



PAGINA DW 0150-3-21

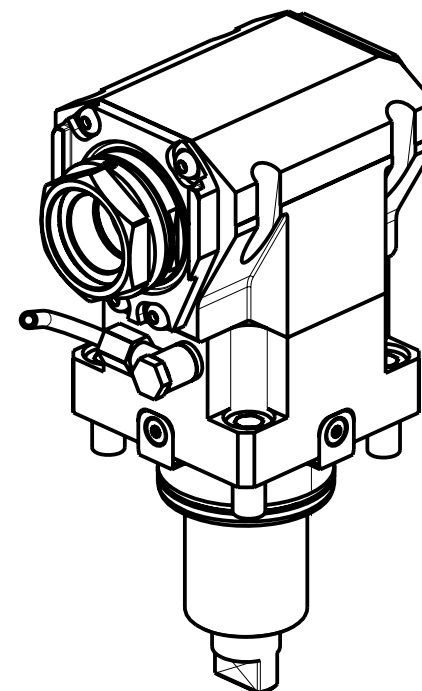
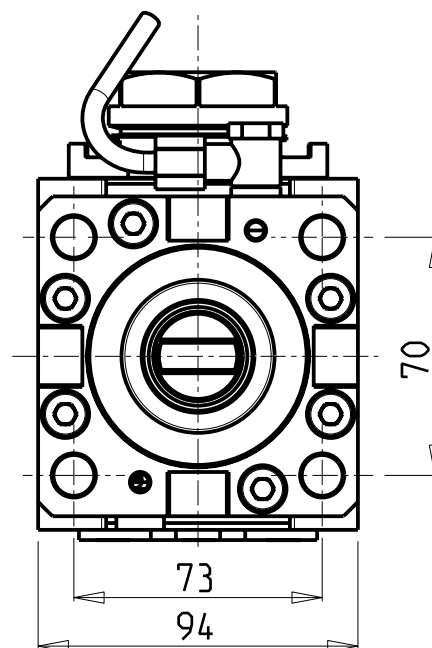
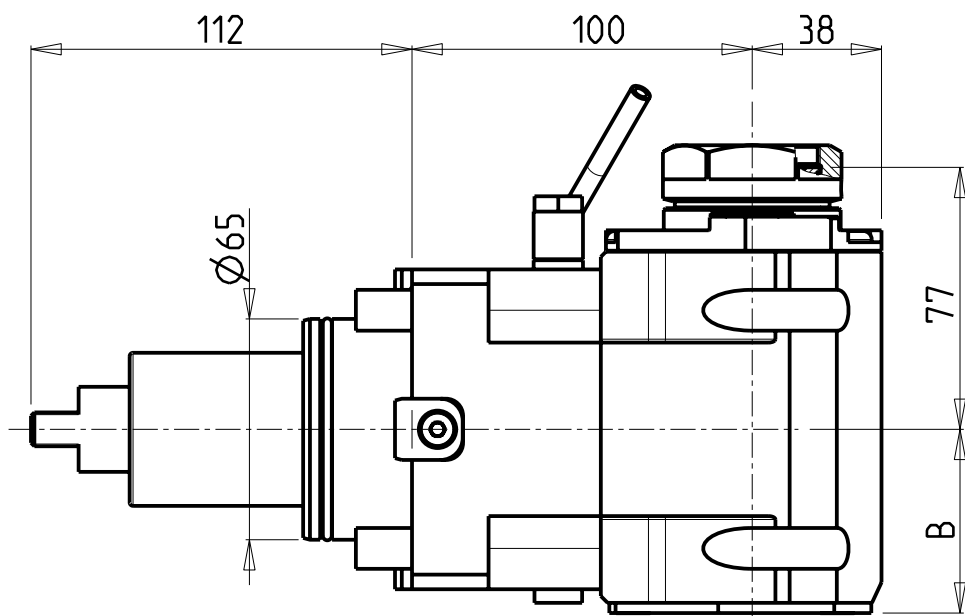

PER PORTAUTENSILI MODULARI MTSK-40 VEDI PAG. TBL300-1-40  
 FOR MTSK-40 QUICK CHANGE TOOLHOLDERS CLAMPINGS SEE PAGE TBL300-1-40  
 FUER MTSK-40 MODULARE WERKZEUGAUFNAHMEN SIEHE SEITE TBL300-1-40

Cod. MT	Mandrino Spindle Spindel	I	RPM	Coppia Max Max Torque Max Drehmoment	Reversibile lato mandrino/contromandrino Reversible sub/main spindle side Umkehrbare Spindel-seite/ Gegenspindel-seite	Lubr.interna Coolant through Innenkuehlung	Lubr.esterna Ext. coolant Ausseinkuehlung	B	CHIAVI NON INCLUSE Keys not included Schluessel nicht einbegriffen	
DW01190140	MTSK-40	1:1	6000	70Nm	X		X	54	CHUB46	OKU0650004 •
DW01190240	MTSK-40	1:1	6000	70Nm	X	P=70bar	X	65	CHUB46	OKU0650004 •

- Chiave inclusa
- Key included
- Schluessel inbegriffen

NEW  
NEW

### DOOSAN BMT 65

MOD: PUMA 300M/MS - V400M - TT2000SY-TT2500SY-TT2500MS - PUMA 2600/3100 SERIE  
 MX2000ST - MX2500LT/ST/LST - VT 450M/TM - PUMA INVERTURN 3000M

MODULO MOTORIZZATO ASSIALE MTSK H=100mm

Axial MTSK driven tool H=100mm

Axial MTSK angetriebenes Werkzeug H=100mm

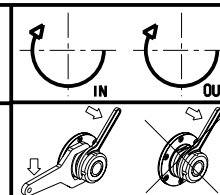

**M.T. srl**  
 Via Casino Albini 480  
 Tel. 0541/956034-957884  
 Fax 0541/956341  
 47842 S. GIOVANNI IN M. (RN)  
 e-mail: mtma@mtmarchetti.com  
 http://www.mtmarchetti.com

PRODUZIONE MODULI ROTANTI



PAGINA DW0150-3-21-K

**ATTENZIONE - ATTENTION - ACHTUNG**

- VERIFICARE LE MISURE DI INGOMBRO PER POSSIBILE INTERFERENZA SU ALCUNI MODELLI DI MACCHINE
- Please check the overall sizes for possible interferences on some machine models
- Bitte überprüfen sie das ausmass um mögliche interferenzen auf einigen maschinen modellen zu vermeiden

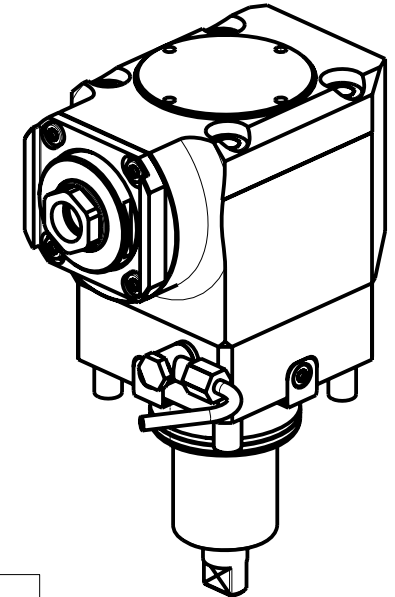
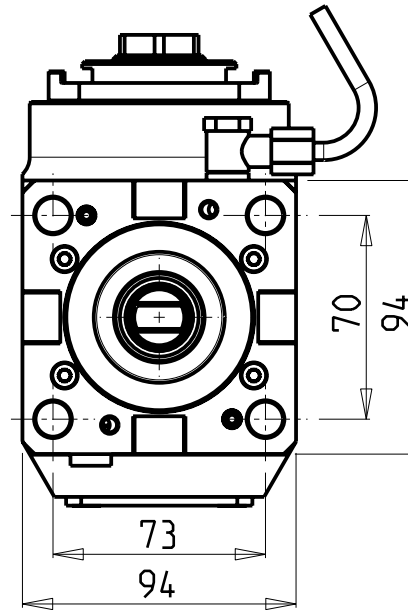
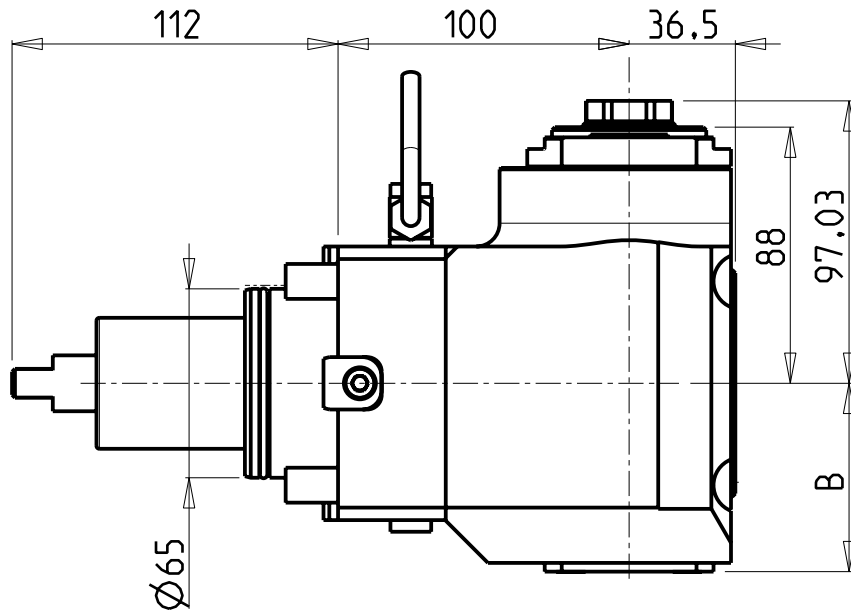

Cod. MT	Mandrino Spindle Spindel	I	RPM	Coppia Max Max Torque Max Drehmoment	Reversibile lato mandrino/contromandrino Reversible sub/main spindle side Umkehrbare Spindel-seite/ Gegenspindel-seite	Lubrificazione int. Coolant through Innenkuehlung	Lubrificazione est. Ext. coolant Aussenkuehlung	B	CHIAVI NON INCLUSE Keys not included Schlüssel nicht einbegriffen	
DW00710125	ER A 25	1:2	12000	30Nm	X		X	64.7	OKU0650004 ■	CHUB27
DW00710225	ER A 25	1:2	12000	30Nm	X	P=70bar	X	73.2	OKU0650004 ■	CHUB27

NEW  
NEW

- Chiave inclusa
- Key included
- Schlüssel einbegriffen

**DOOSAN BMT 65**  
 MOD: V400M - TT2000SY-TT2500SY-TT2500MS - PUMA 2600/3100 SERIE  
 MX2000ST - MX2500LT/ST/LST - MX2600T-ST - VT 450M/TM - PUMA INVERTURN 3000M  
 MODULO MOTORIZZATO ASSIALE MOLTIPLICATO I=1:2  
 Axial geared-up I=1:2 driven tool  
 Axial angetriebenes Werkzeug uebersetzt I=1:2

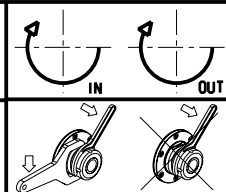

**M.T. srl**  
 Via Casino Albini 480  
 Tel. 0541/956034-957884  
 Fax 0541/956341  
 47842 S. GIOVANNI IN M. (RN)  
 e-mail: mtma@mtmarchetti.com  
 http://www.mtmarchetti.com

PRODUZIONE MODULI ROTANTI

PAGINA DW 0200-3-20

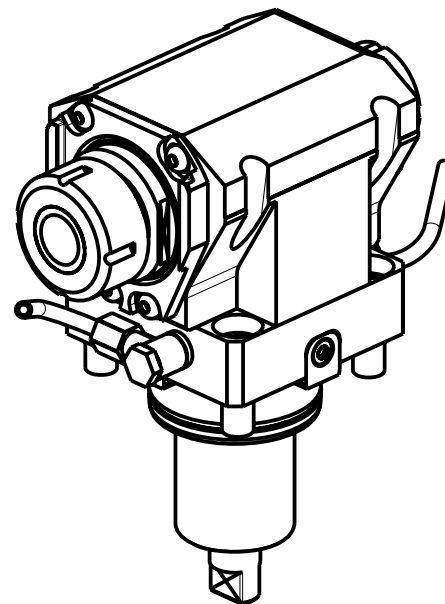
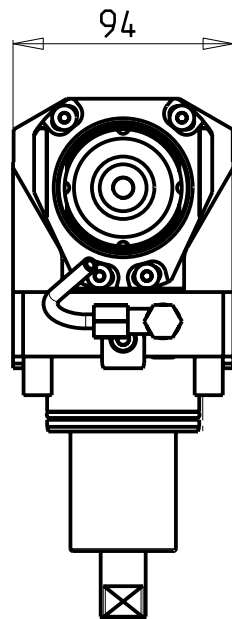
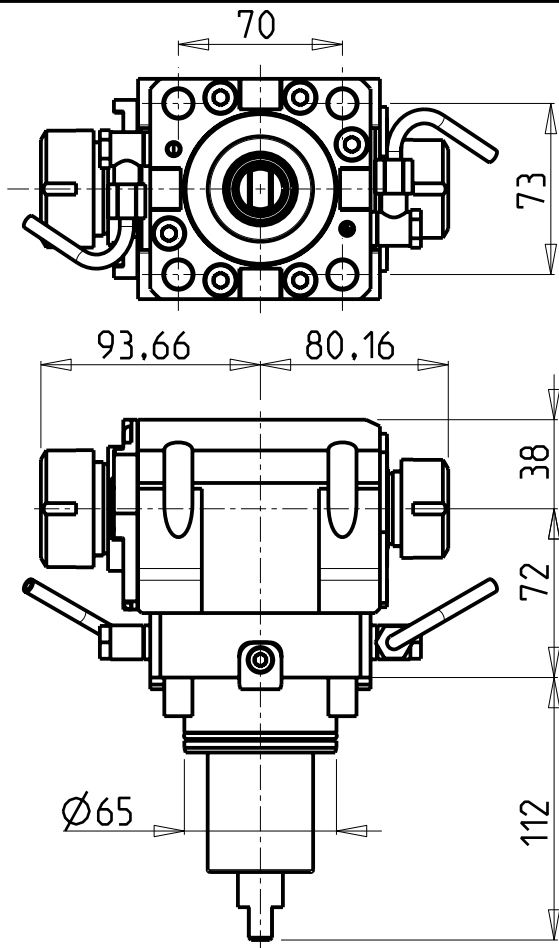

### ATTENZIONE - ATTENTION - ACHTUNG

- Per lo smontaggio degli utensili utilizzare sempre la chiave di contrasto come indicato nel manuale d'uso.
- For disassembly of the tools use always the contrast key as mentioned in the user instructions.
- Fuer das Abmontieren der Werkzeuge immer den Gegenschlüssel benutzen wie in der Bedienungsanleitung erwäehnt.

Cod. MT	Mandrino Spindle Spindel	I	RPM	Coppia Max Max Torque Max Drehmoment	Reversibile lato mandrino/contromandrino Reversible sub/main spindle side Umkehrbare Spindel-seite/ Gegenspindel-seite	Lubr.esterna Ext. coolant Aussenkuehlung	CHIAVI NON INCLUSE Keys not included Schluesssel nicht einbegriffen			
DW00720132	ER32+ER25	1:1	6000	70Nm	X	X	CHSTER32	CHSTER25	OKU0650004	NEW

- Chiave inclusa
- Key included
- Schluesssel inbegriffen

## DOOSAN BMT 65

MOD: PUMA 300M/MS - V400M - TT2000SY-TT2500SY-TT2500MS - PUMA 2600/3100 SERIE  
MX2000ST - MX2500LT/ST/LST - VT 450M/TM - PUMA INVERTURN 3000M

MODULO MOTORIZZATO ASSIALE BISPORGENTE H=72mm

Axial opposite face driven tool H=72mm

Axial angetriebenes Werkzeug halb vorspringend H=72mm

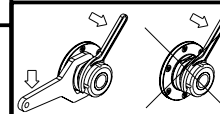

### M.T. srl

Via Casino Albini 480  
Tel. 0541/956034-957884  
Fax 0541/956341

47842 S. GIOVANNI IN M. (RN)  
e-mail: mtma@mtmarchetti.com  
http://www.mtmarchetti.com

PRODUZIONE MODULI ROTANTI



PAGINA DW0240-3-10

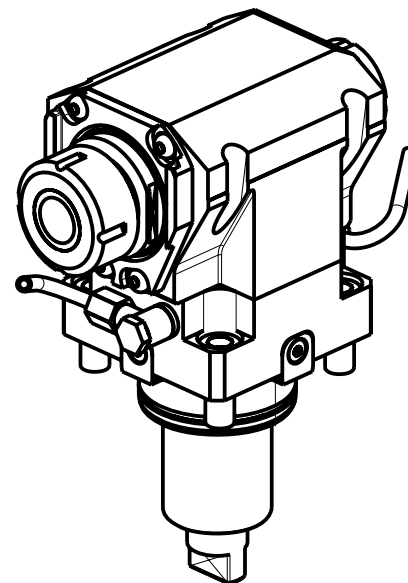
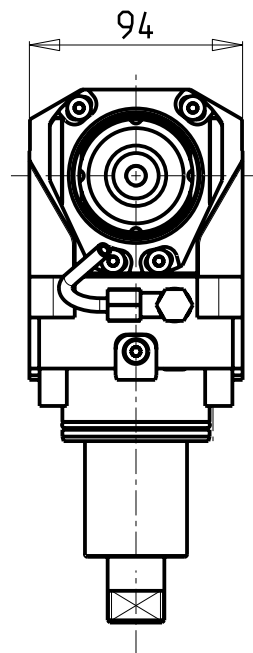
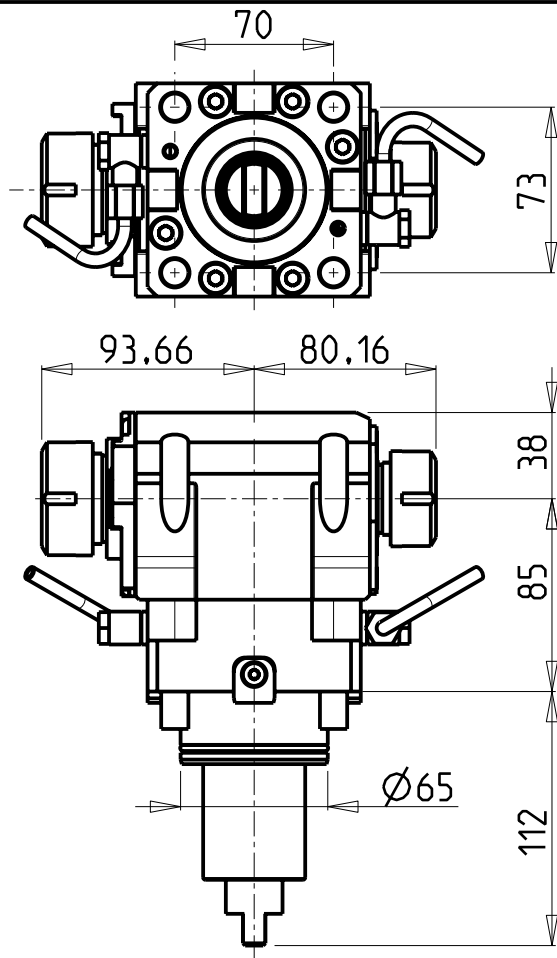

### ATTENZIONE - ATTENTION - ACHTUNG

- Per lo smontaggio degli utensili utilizzare sempre la chiave di contrasto come indicato nel manuale d'uso.
- For disassembly of the tools use always the contrast key as mentioned in the user instructions.
- Fuer das Abmontieren der Werkzeuge immer den Gegenschlüssel benutzen wie in der Bedienungsanleitung erwäehnt.

Cod. MT	Mandrino Spindle Spindel	I	RPM	Coppia Max Max Torque Max Drehmoment	Reversibile lato mandrino/contromandrino Reversible sub/main spindle side Umkehrbare Spindelseite/ Gegenspindelseite	Lubr.esterna Ext. coolant Aussenkuehlung	CHIAVI NON INCLUSE Keys not included Schluessel nicht einbegriffen		
DW01150132	ER32+ER25	1:1	6000	70Nm	X	X	CHSTER32	CHSTER25	OKU0650004 • NEW

- Chiave inclusa
- Key included
- Schluessel inbegriffen

## DOOSAN BMT 65

MOD: PUMA 300M/MS - V400M - TT2000SY-TT2500SY-TT2500MS - PUMA 2600/3100 SERIE  
MX2000ST - MX2500LT/ST/LST - VT 450M/TM - PUMA INVERTURN 3000M

MODULO MOTORIZZATO ASSIALE BISPORGENTE H=85mm

Axial opposite face driven tool H=85mm

Axial angetriebenes Werkzeug halb vorspringend H=85mm

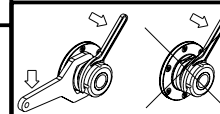

### M.T. srl

Via Casino Albini 480  
Tel. 0541/956034-957884  
Fax 0541/956341

47842 S. GIOVANNI IN M. (RN)  
e-mail: mtma@mtmarchetti.com  
http://www.mtmarchetti.com

PRODUZIONE MODULI ROTANTI



PAGINA DW0240-3-15

**ATTENZIONE - ATTENTION - ACHTUNG**

- Per lo smontaggio degli utensili utilizzare sempre la chiave di contrasto come indicato nel manuale d'uso.
- For disassembly of the tools use always the contrast key as mentioned in the user instructions.
- Fuer das Abmontieren der Werkzeuge immer den Gegenschlüssel benutzen wie in der Bedienungsanleitung erwäehnt.

**ATTENZIONE - ATTENTION - ACHTUNG**

- VERIFICARE LE MISURE DI INGOMBRO PER POSSIBILE INTERFERENZA SU ALCUNI MODELLI DI MACCHINE
- Please check the overall sizes for possible interferences on some machine models
- Bitte überprüfen sie das ausmass um mögliche interfeerenzen auf einigen maschinen modellen zu vermeiden

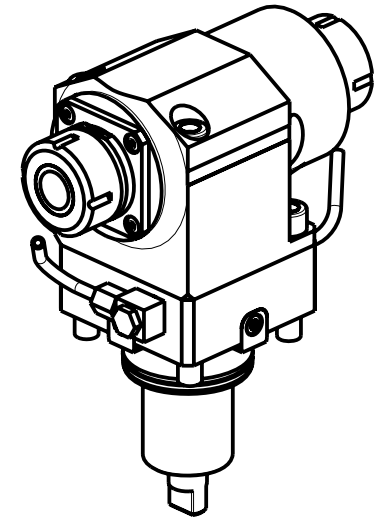
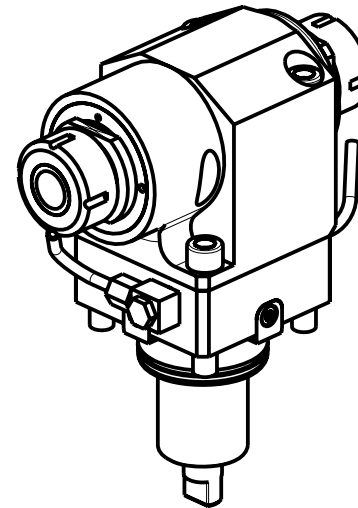
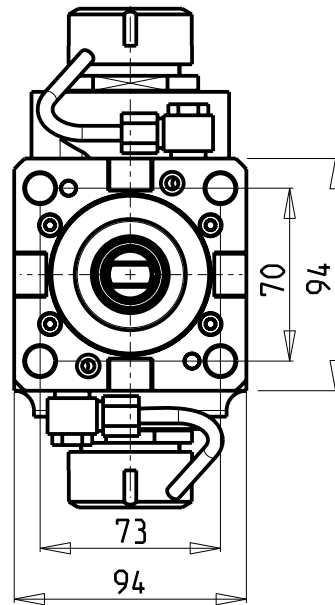
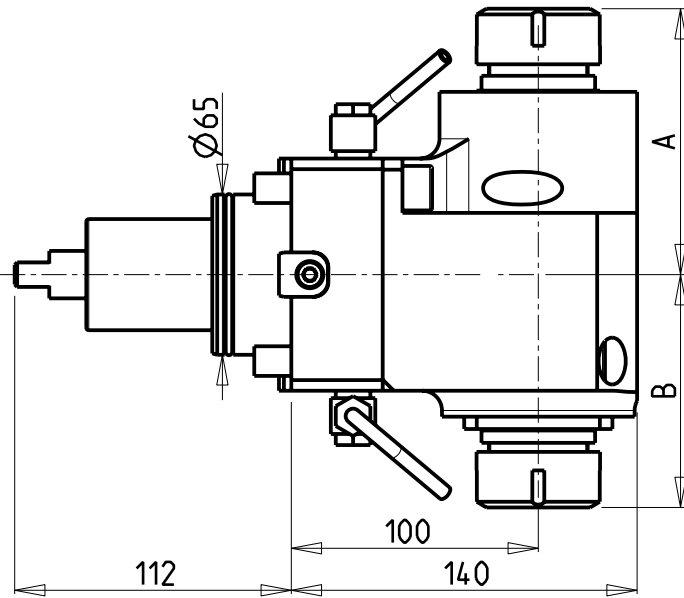

Cod. MT	Mandrino Spindle Spindel	I	RPM	Coppia Max Max Torque Max Drehmoment	Reversibile lato mandrino/contromandrino Reversible sub/main spindle side Umkehrbare Spindel-seite/ Gegenspindel-seite	Lubrificazione est. Ext. coolant Ausseukuehlung	A	B	CHIAVI NON INCLUSE Keys not included Schlüssel nicht einbegriffen		
									CHSTER32	CHUB46	
DW 00070232	ER32+ER32	1:1	6000	70Nm	X	X	107.66	94.26	CHSTER32	CHUB46	
DW 00073225	ERA25+ERA32	1:1	6000	70Nm	X	X	106.03	81.13	CHUB27	CHUB32	CHUB46

**DOOSAN BMT 65**

MOD: V400M - TT2000SY-TT2500SY-TT2500MS - PUMA 2600/3100 SERIE  
 MX2000ST - MX2500LT/ST/LST - MX2600T-ST - VT 450M/TM - PUMA INVERTURN 3000M

MODULO MOTORIZZATO ASSIALE BISPORGENTE H=100mm

Axial opposite face twin driven tool H=100mm

Axial angetriebenes Werkzeug halb vorspringend H=100mm

**M.T. srl**

Via Casino Albini 480  
 Tel. 0541/956034-957884  
 Fax 0541/956341  
 47842 S. GIOVANNI IN M. (RN)  
 e-mail: mtma@mtmarchetti.com  
 http://www.mtmarchetti.com

PRODUZIONE MODULI ROTANTI



PAGINA DW 0240-3-20

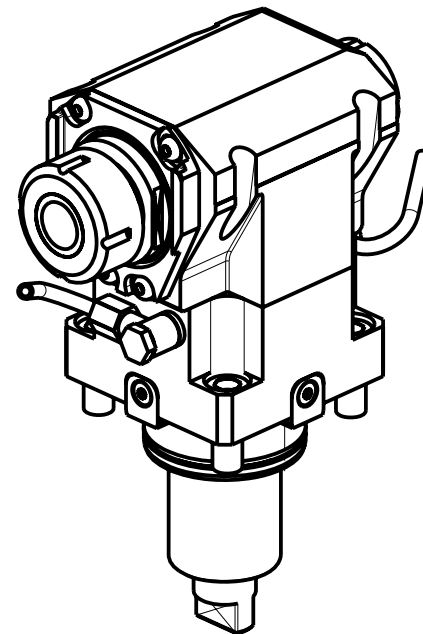
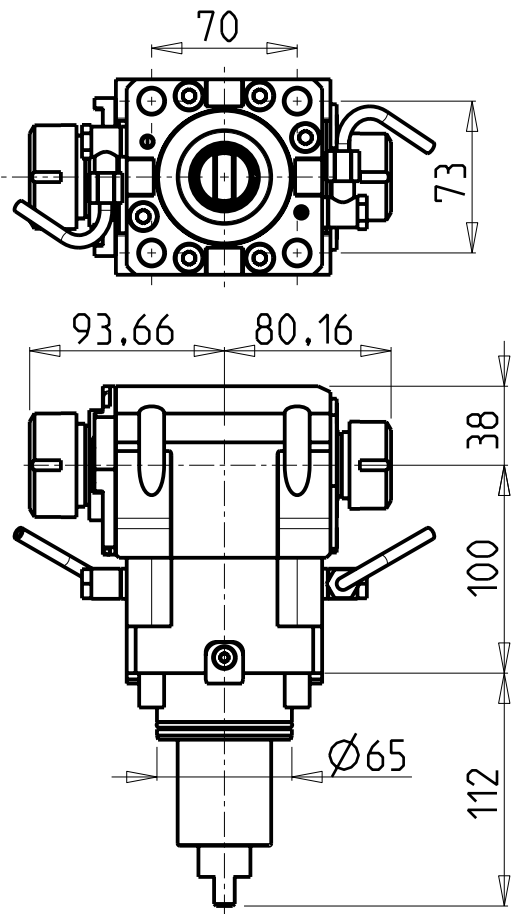

### ATTENZIONE - ATTENTION - ACHTUNG

- Per lo smontaggio degli utensili utilizzare sempre la chiave di contrasto come indicato nel manuale d'uso.
- For disassembly of the tools use always the contrast key as mentioned in the user instructions.
- Fuer das Abmontieren der Werkzeuge immer den Gegenschlüssel benutzen wie in der Bedienungsanleitung erwäehnt.

### ATTENZIONE - ATTENTION - ACHTUNG

- VERIFICARE LE MISURE DI INGOMBRO PER POSSIBILE INTERFERENZA SU ALCUNI MODELLI DI MACCHINE
- Please check the overall sizes for possible interferences on some machine models
- Bitte überprüfen sie das ausmass um mögliche interferenzen auf einigen maschinen modellen zu vermeiden

Cod. MT	Mandrino Spindle Spindel	I	RPM	Coppia Max Max Torque Max Drehmoment	Reversibile lato mandrino/contromandrino Reversible sub/main spindle side Umkehrbare Spindel-seite/ Gegenspindel-seite	Lubr.esterna Ext. coolant Aussenkuehlung	CHIAVI NON INCLUSE Keys not included Schluessel nicht einbegriffen			
DW01160132	ER32+ER25	1:1	6000	70Nm	X	X	CHSTER32	CHSTER25	OKU0650004	NEW

- Chiave inclusa
- Key included
- Schluessel inbegriffen

## DOOSAN BMT 65

MOD: PUMA 300M/MS - V400M - TT2000SY-TT2500SY-TT2500MS - PUMA 2600/3100 SERIE  
MX2000ST - MX2500LT/ST/LST - VT 450M/TM - PUMA INVERTURN 3000M

MODULO MOTORIZZATO ASSIALE BISPORGENTE H=100mm

Axial opposite face driven tool H=100mm

Axial angetriebenes Werkzeug halb vorspringend H=100mm

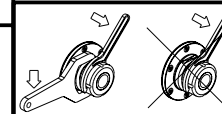

### M.T. srl

Via Casino Albini 480  
Tel. 0541/956034-957884  
Fax 0541/956341  
47842 S. GIOVANNI IN M. (RN)  
e-mail: mtma@mtmarchetti.com  
http://www.mtmarchetti.com

PRODUZIONE MODULI ROTANTI



PAGINA DW0240-3-21

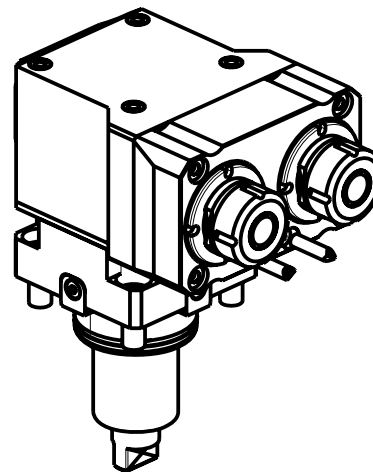
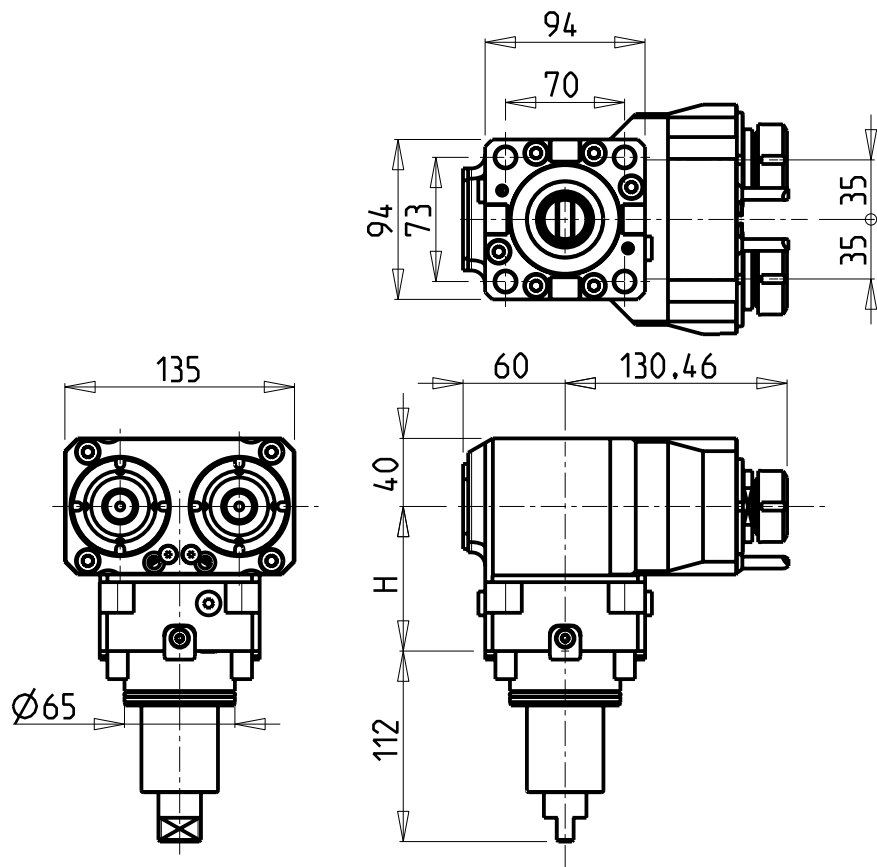

### ATTENZIONE - ATTENTION - ACHTUNG

- Su macchine TT2000/2500SY-TT2500MS solo i motorizzati H=100 arrivano a centro mandrino
- The driven tools with H=100 reach the spindle axis only on lathes TT2000/2500SY-TT2500MS
- Auf TT2000/2500SY-TT2500MS Maschinen erreichen nur die angetriebenen Werkzeugen mit H=100 das Zentrum der Spindel

### ATTENZIONE - ATTENTION - ACHTUNG

- Per lo smontaggio degli utensili utilizzare sempre la chiave di contrasto come indicato nel manuale d'uso.
- For disassembly of the tools use always the contrast key as mentioned in the user instructions.
- Fuer das Abmontieren der Werkzeuge immer den Gegenschluessel benutzen wie in der Bedienungsanleitung erwaeht.

Cod. MT	Mandrino Spindle Spindel	I	RPM	Coppia Max Max Torque Max Drehmoment	Reversibile lato mandrino/contromandrino Reversible sub/main spindle side Umkehrbare Spindel-seite/ Gegenspindel-seite	Lubrificazione est. Ext. coolant Aussenkuehlung	H	CHIAVI NON INCLUSE Keys not included Schluessel nicht einbegriffen	
DW 01120225	ER25	1:1	6000	40Nm	X	X	72	CHUB36	CHSTER25
DW 01220225	ER25	1:1	6000	40Nm	X	X	85	CHUB36	CHSTER25
DW 01230225	ER25	1:1	6000	40Nm	X	X	100	CHUB36	CHSTER25

NEW

NEW

NEW

## DOOSAN BMT 65

MOD: PUMA 300M/MS - V400M - TT2000SY-TT2500SY-TT2500MS - PUMA 2600/3100 SERIE  
VT 450M/TM - PUMA INVERTURN 3000M

MODULO MOTORIZZATO ASSIALE 2 USCITE IN Y

Axial single side twin head driven tool in Y

Axial angetriebenes Werkzeug 2 Ausgaenge in Y

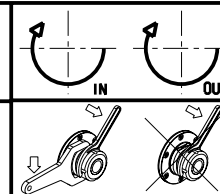

## M.T. srl

Via Casino Albini 480  
Tel. 0541/956034-957884  
Fax 0541/956341

47842 S. GIOVANNI IN M. (RN)  
e-mail: mtma@mtmarchetti.com  
http://www.mtmarchetti.com

PRODUZIONE MODULI ROTANTI



PAGINA DW 0260-3-10



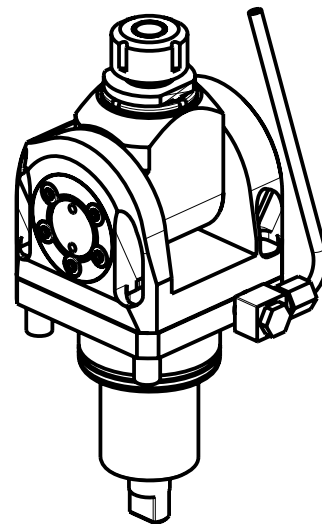
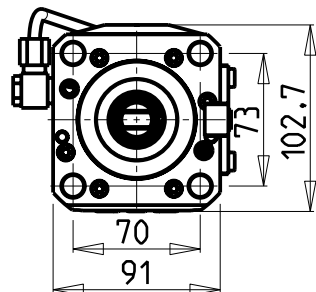
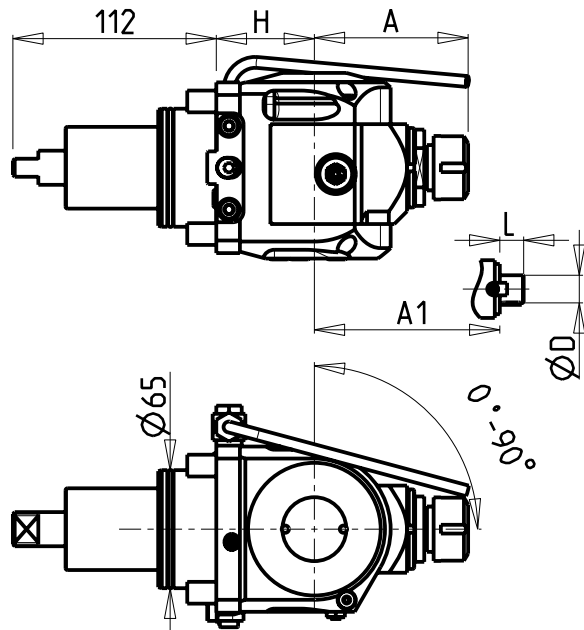

### ATTENZIONE - ATTENTION - ACHTUNG

- VERIFICARE LE MISURE DI INGOMBRO PER POSSIBILE INTERFERENZA SU ALCUNI MODELLI DI MACCHINE
- Please check the overall sizes for possible interferences on some machine models
- Bitte überprüfen sie das ausmass um mögliche interferenzen auf einigen maschinen modellen zu vermeiden

Cod. MT	Mandrino Spindle Spindel	I	RPM	Coppia Max Max Torque Max Drehmoment	Reversibile lato mandrino/contromandrino Reversible sub/main spindle side Umkehrbare Spindel-seite/ Gegenspindel-seite	Lubr.esterna Ext. coolant Aussenkuehlung	H	A	A1	D	L	CHIAVI INCLUSE Keys included Schluessel inbegriffen		
												CHSTER20	CHUB36	CHESL10
0370020	ER20	1:1	6000	40Nm	X	X	54	84.66	-	-	-	CHSTER20	CHUB36	CHESL10
0370120	ER20	1:1	6000	40Nm	X	X	100	84.66	-	-	-	CHSTER20	CHUB36	CHESL10
0370025	ER25	1:1	6000	40Nm	X	X	54	85.66	-	-	-	CHSTER25	CHUB36	CHESL10
0370125	ER25	1:1	6000	40Nm	X	X	100	85.66	-	-	-	CHSTER25	CHUB36	CHESL10
0371617	Ø16x17	1:1	6000	40Nm	X	X	54	-	65	16	17	CH_VTCROCE_M08	CHUB36	CHESL10
0372617	Ø16x17	1:1	6000	40Nm	X	X	100	-	65	16	17	CH_VTCROCE_M08	CHUB36	CHESL10
0372219	Ø22x19	1:1	6000	40Nm	X	X	54	-	66	22	19	CH_VTCROCE_M10	CHUB36	CHESL10
0373219	Ø22x19	1:1	6000	40Nm	X	X	100	-	66	22	19	CH_VTCROCE_M10	CHUB36	CHESL10
0371905	Ø3/4"x3/4"	1:1	6000	40Nm	X	X	54	-	65	3/4"	3/4"	CH_VTCROCE_M08	CHUB36	CHESL10
0372905	Ø3/4"x3/4"	1:1	6000	40Nm	X	X	100	-	65	3/4"	3/4"	CH_VTCROCE_M08	CHUB36	CHESL10

### DOOSAN BMT 65

MOD: PUMA 300M/MS - V400M - TT2000SY-TT2500SY-TT2500MS - PUMA 2600/3100 SERIE  
MX2000ST - MX2500LT/ST/LST - MX2600T-ST - VT 450M/TM - PUMA INVERTURN 3000M

MODULO MOTORIZZATO ORIENTABILE 0-90°

0-90° adjustable angle driven tool

Angetriebenes Werkzeug schwenkbar 0-90°

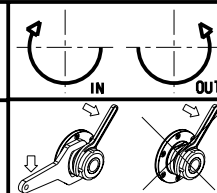

### M.T. srl

Via Casino Albini 480  
Tel. 0541/956034-957884

Fax 0541/956341

47842 S. GIOVANNI IN M. (RN)

e-mail: mtma@mtmarchetti.com

http://www.mtmarchetti.com

PRODUZIONE MODULI ROTANTI



PAGINA DW 0330-3-00

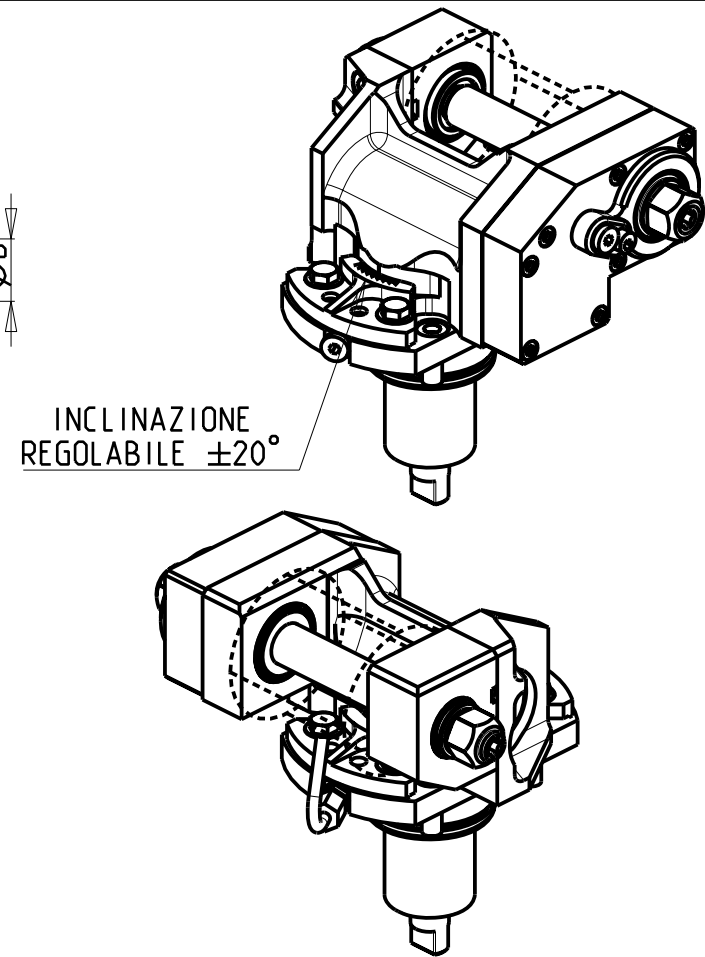
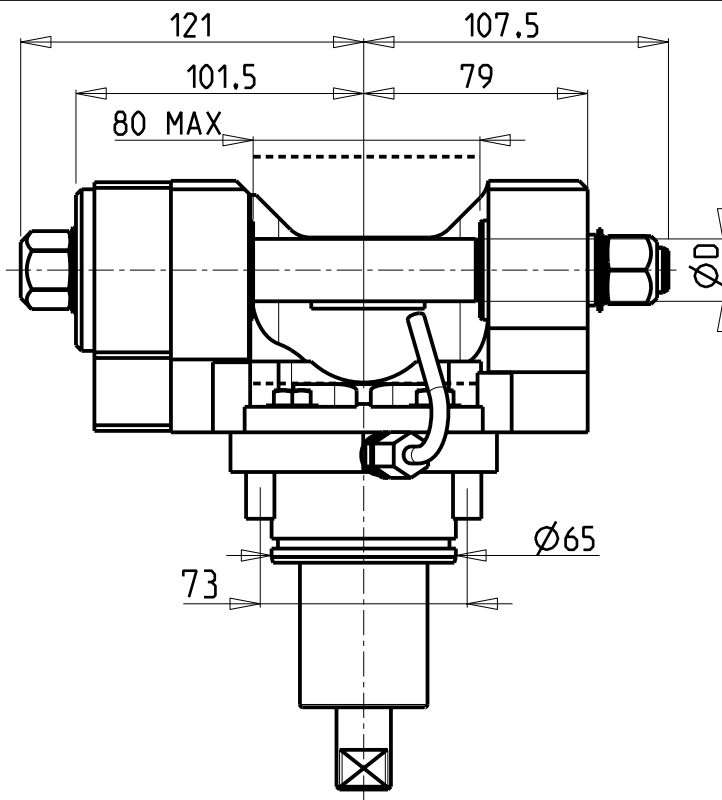
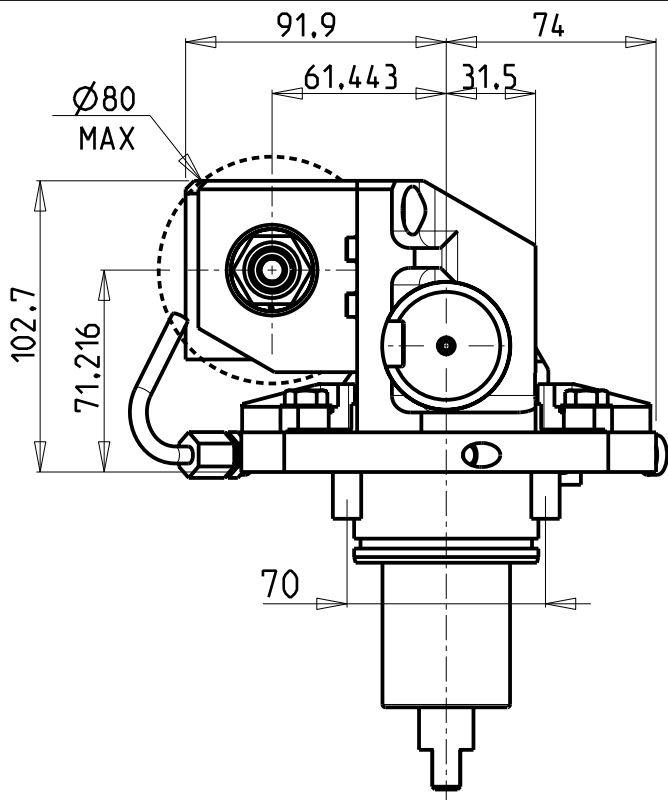

**DOTAZIONI - SUPPLIED WITH - AUSSTATTUNG**

- mm / inch**
- N°1 ALBERO + DISTANZIALI
  - N°1 SHAFT + SPACER
  - N°1 DORN + ABSTANDSSTUECK

PER ALBERI E DISTANZIALI VEDI PAG. TBL250-1-00  
 FOR SHAFT END SPACER SEE PAGE TBL250-1-00  
 FUER DORN UND ABSTANDSSTUECK SEITE TBL250-1-00

Cod. MT	I	RPM	Coppia Max Max Torque Max Drehmoment	Reversibile lato mandrino/contromandrino Reversible sub/main spindle side Umkehrbare Spindel-seite/ Gegenspindel-seite	Lubrificazione est. Ext. coolant Aussenkuehlung	D (mm)	D (Inch)	CHIAVI INCLUSE Keys included Schlüssel inbegriffen		
				X	X	16-22-27-32	3/4"-1"-1 1/4"	CHUB24	CHUB13	CHESL08
0321100	1:1	6000	60Nm	X	X	16-22-27-32	3/4"-1"-1 1/4"	CHUB24	CHUB13	CHESL08
0322100	2:1	3000	80Nm	X	X	16-22-27-32	3/4"-1"-1 1/4"	CHUB24	CHUB13	CHESL08

**DOOSAN BMT 65**

MOD: PUMA 300M/MS - V400M - TT2000SY-TT2500SY-TT2500MS - PUMA 2600/3100 SERIE  
 MX2000ST - MX2500LT/ST/LST - MX2600T-ST - VT 450M/TM - PUMA INVERTURN 3000M

MODULO MOTORIZZATO PORTACREATORE

Driven gear hobber

Angetriebenes Zahnradwaelzfraes-Werkzeug

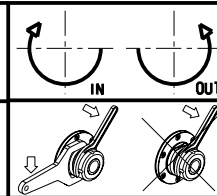

**M.T. srl**

Via Casino Albini 480  
 Tel. 0541/956034-957884  
 Fax 0541/956341

47842 S. GIOVANNI IN M. (RN)  
 e-mail: mtma@mtmarchetti.com  
 http://www.mtmarchetti.com

PRODUZIONE MODULI ROTANTI



PAGINA DW0340-3-00

**ATTENZIONE - ATTENTION - ACHTUNG**

- VERIFICARE LE MISURE DI INGOMBRO PER POSSIBILE INTERFERENZA SU ALCUNI MODELLI DI MACCHINE
- Please check the overall sizes for possible interferences on some machine models
- Bitte überprüfen sie das ausmass um mögliche interferenzen auf einigen maschinen modellen zu vermeiden

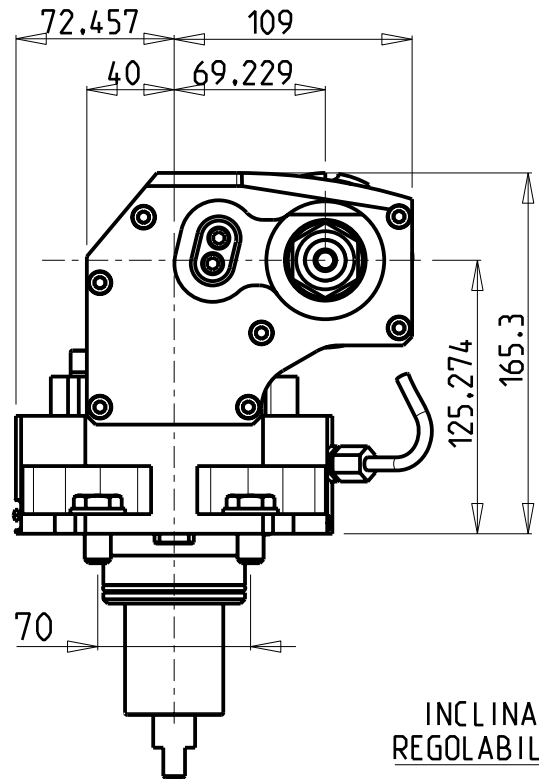
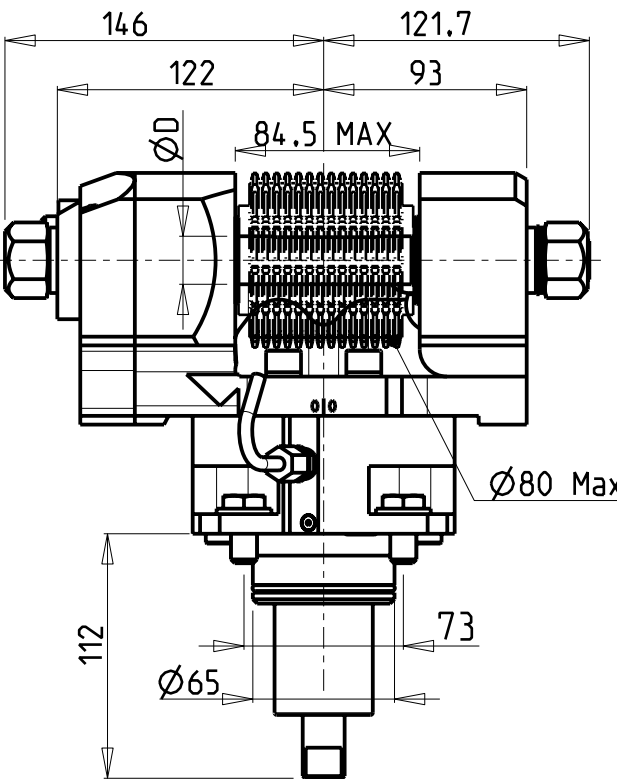

INCLINAZIONE REGOLABILE ±30°

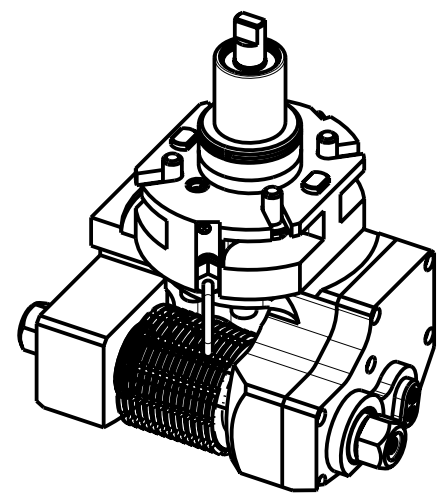
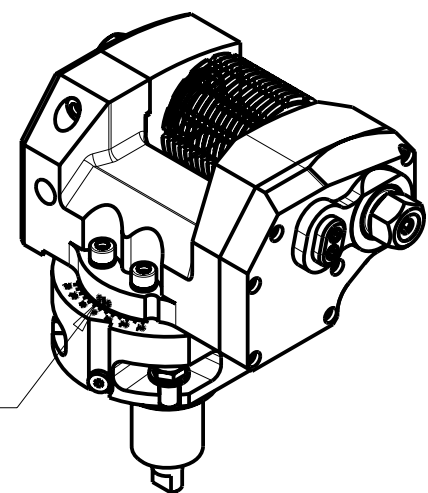

**DOTAZIONI - SUPPLIED WITH - AUSSTATTUNG**

- mm / inch
- N°1 ALBERO + DISTANZIALI
  - N°1 SHAFT + SPACER
  - N°1 DORN + ABSTANDSSTUECK

PER ALBERI E DISTANZIALI VEDI PAG. TBL250-1-00  
 FOR SHAFT END SPACER SEE PAGE TBL250-1-00  
 FUER DORN UND ABSTANDSSTUECK SEITE TBL250-1-00

Cod. MT	I	RPM	Coppia Max Max Torque Max Drehmoment	Lubrificazione est. Ext. coolant Aussenkuehlung	D (mm)	D (Inch)	CHIAVI INCLUSE Keys included Schlüssel inbegriffen			
							CHUB30	CHUB19	CHESL08	CHUB24 (Ø16 / Ø3/4")
DW 00031100	1:1	6000	90Nm	X	16-22-27-32	3/4"-1"-1 1/4"	CHUB30	CHUB19	CHESL08	CHUB24 (Ø16 / Ø3/4")
DW 00032100	2:1	3000	110Nm	X	16-22-27-32	3/4"-1"-1 1/4"	CHUB30	CHUB19	CHESL08	CHUB24 (Ø16 / Ø3/4")

**DOOSAN BMT 65**

MOD: PUMA 300M/MS - V400M - TT2000SY-TT2500SY-TT2500MS - PUMA 2600/3100 SERIE  
 VT 450M/TM - PUMA INVERTURN 3000M

MODULO MOTORIZZATO PORTACREATORE MAGGIORATO

Reinforced driven gear hobber

Angetriebenes Zahnradwaelzfraes-Werkzeug vergroessert

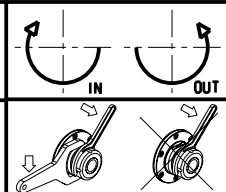

**M.T. srl**

Via Casino Albini 480  
 Tel. 0541/956034-957884  
 Fax 0541/956341  
 47842 S. GIOVANNI IN M. (RN)  
 e-mail: mtma@mtmarchetti.com  
 http://www.mtmarchetti.com

PRODUZIONE MODULI ROTANTI



PAGINA DW 0340-3-60

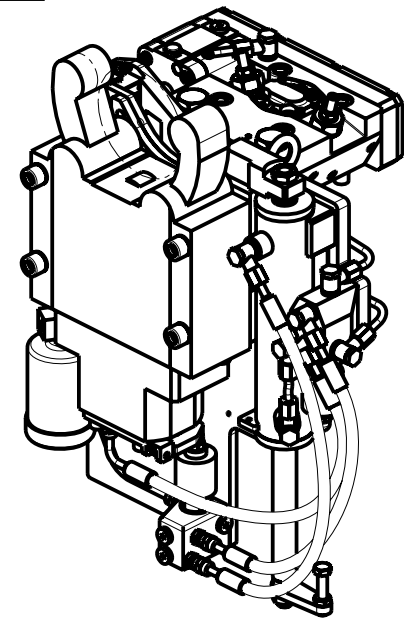
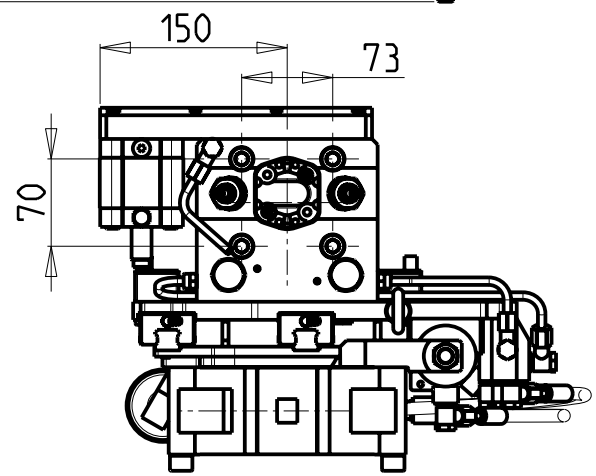
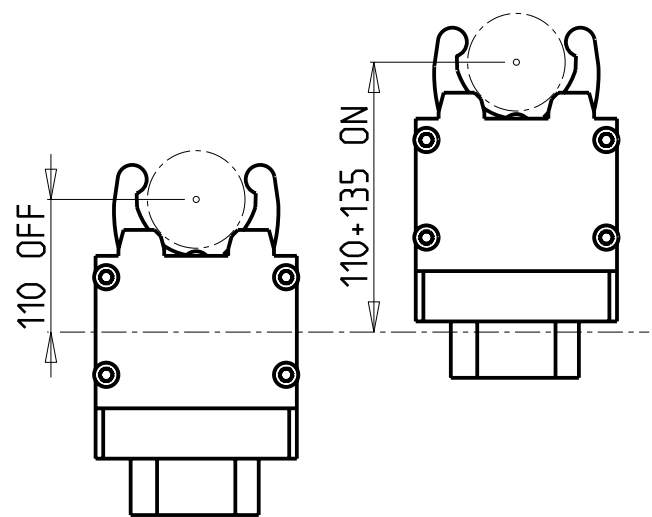
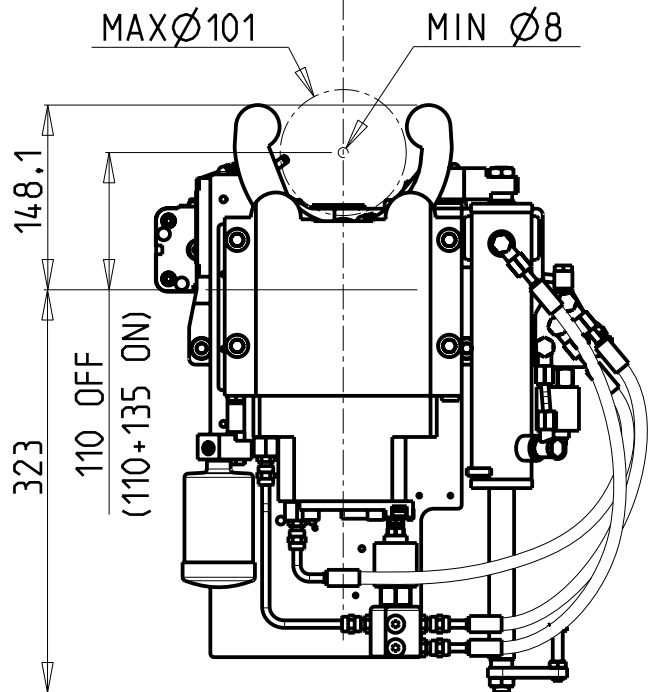
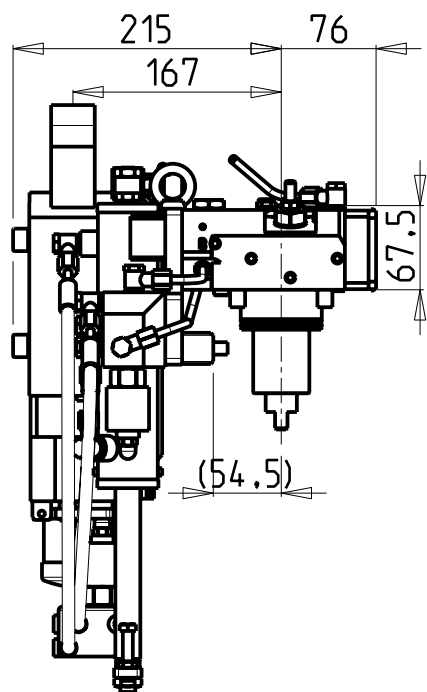

- #  CON GESTIONE ELETTRONICA APERTURA COMPLETA DELLA LUNETTA
- # With Electronic control of steady rest arms complete opening
- # Mit vollständiger elektronischer Öffnungsbedienung der Luenette

Cod. MT	I	RPM	Lubr.esterna Ext. coolant Aussenkuehlung	
DW00940300	1:1	6000	X	NEW
# DW00940300A	1:1	6000	X	NEW

DOOSAN BMT 65

MOD: TT2000SY-TT2500SY-TT2500MS - MX2000ST - MX2500LT/ST/LST - MX2600ST

MODULO MOTORIZZATO PER LUNETTA RETRATTILE (TAGLIA 2)

Driven toolholder for sliding steady rest (Size 2)

Luenettenwerkzeug zurueck versetzte Version (Groesse 2)

**M.T. srl**  
 Via Casino Albini 480  
 Tel. 0541/956034-957884  
 Fax 0541/956341  
 47842 S. GIOVANNI IN M. (RN)  
 e-mail: mtma@mtmarchetti.com  
 http://www.mtmarchetti.com

PRODUZIONE MODULI ROTANTI



PAGINA DW0363-3-00

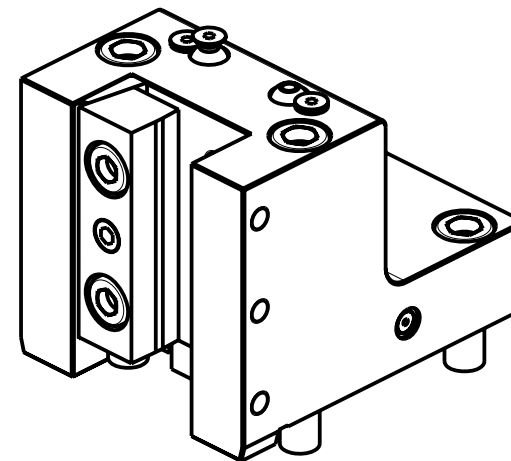
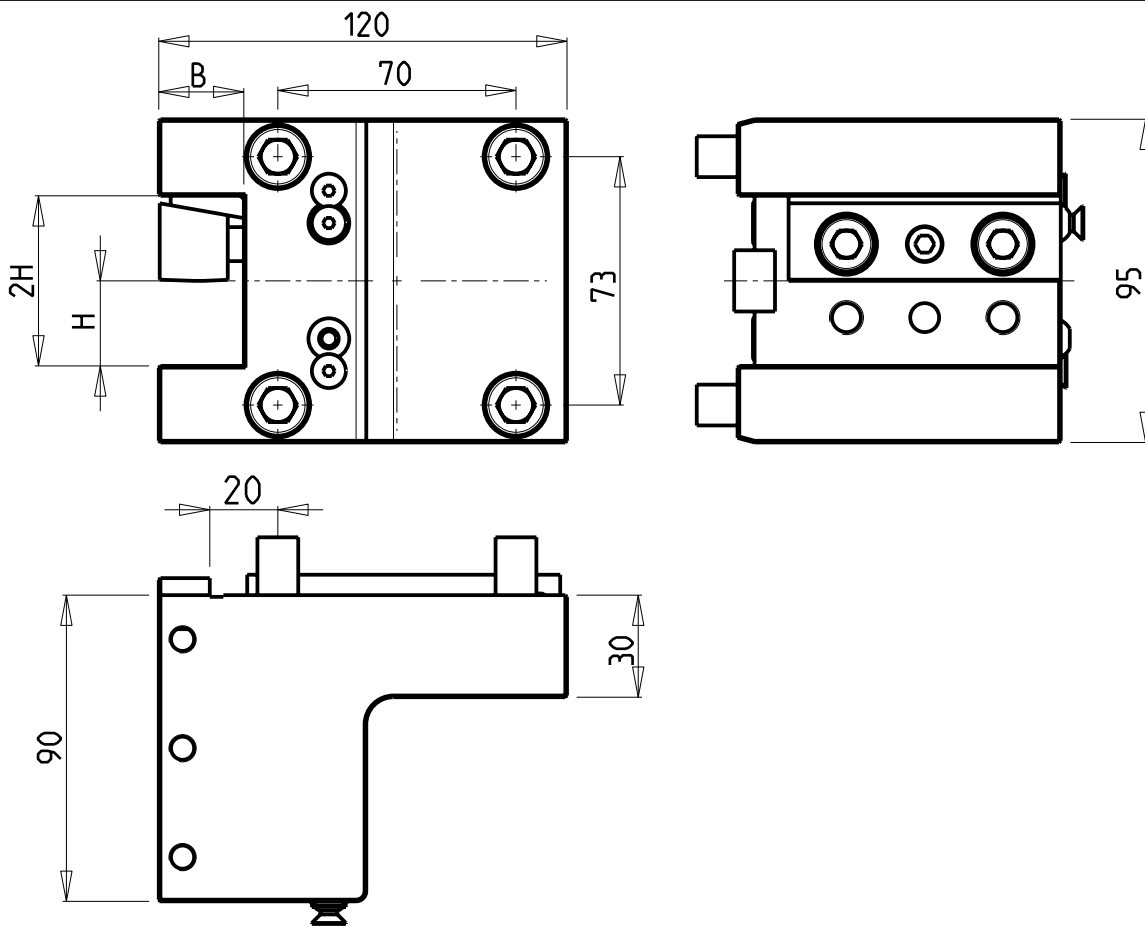

Cod. MT	N°Utensili N°Tools N°Werkzeuge	Reversibile lato mandrino/contromandrino Reversible sub/main spindle side Umkehrbare Spindel-seite/ Gegenspindel-seite	Misure Dimensions Masse	B	H
DW00482500	1	X	mm	25	25
DW00482540	1	X	Inch	1"	1"

NEW

DAEW00 BMT 65

MOD: PUMA 300M/MS - V400M - TT2000SY-TT2500SY-TT2500MS - PUMA 2600/3100 SERIE  
MX2000ST - MX2500LT/ST/LST - MX2600T-ST - VT 450M/TM - PUMA INVERTURN 3000M

PORTAUTENSILE RADIALE SINGOLO

Radial single static tool

Radial Single-Werkzeughalter

**M.T. srl**

Via Casino Albini 480  
Tel. 0541/956034-957884  
Fax 0541/956341  
47842 S. GIOVANNI IN M. (RN)  
e-mail: mtma@mtmarchetti.com  
http://www.mtmarchetti.com

PRODUZIONE MODULI ROTANTI



PAGINA DW0423-3-00

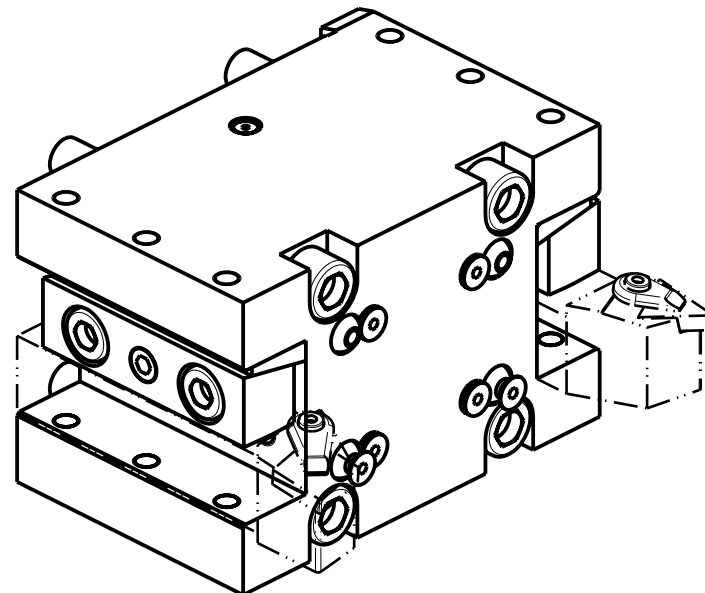
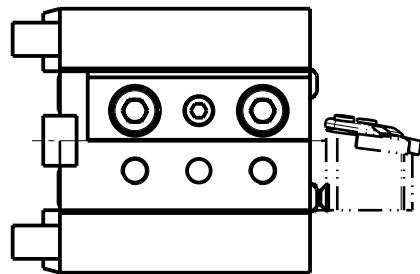
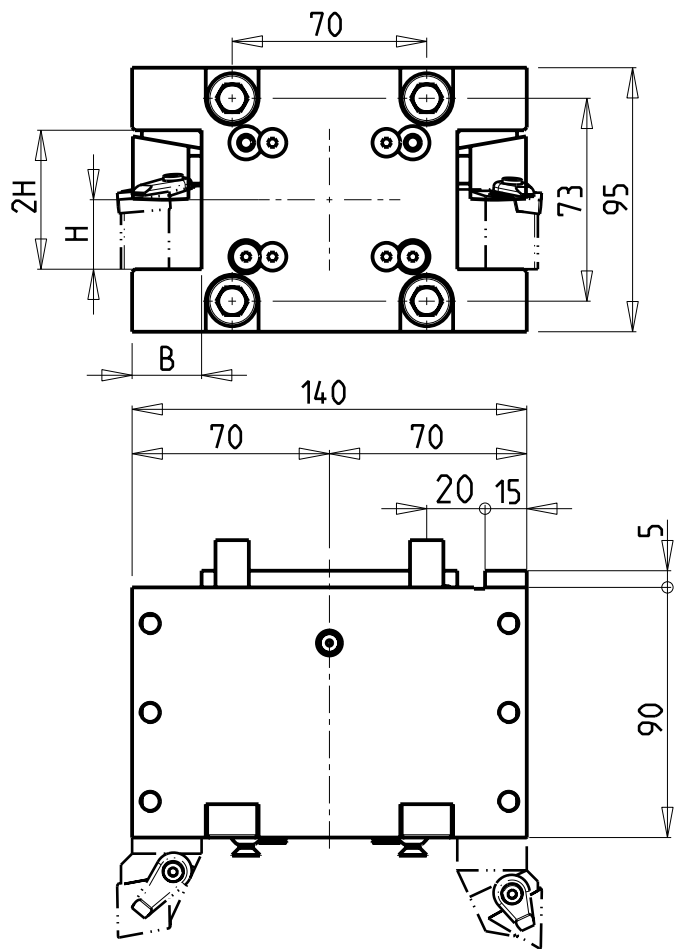

Cod. MT	N°Utensili N°Tools N°Werkzeuge	Reversibile lato mandrino/contromandrino Reversible sub/main spindle side Umkehrbare Spindel-seite/ Gegenspindel-seite	Misure Dimensions Masse	B	H
DW 00272500	2/4	X	mm	25	25
DW 00272540	2/4	X	Inch	1"	1"

## DOOSAN BMT 65

MOD: PUMA 300M/MS - V400M - TT2000SY-TT2500SY-TT2500MS - PUMA 2600/3100 SERIE  
MX2000ST - MX2500LT/ST/LST - MX2600T-ST - VT 450M/TM - PUMA INVERTURN 3000M

PORTAUTENSILE RADIALE DOPPIO H=90mm

Radial double static tool H=90mm

Radial Doppel-Werkzeughalter H=90mm

## M.T. srl

Via Casino Albini 480  
Tel. 0541/956034-957884  
Fax 0541/956341  
47842 S. GIOVANNI IN M. (RN)  
e-mail: mtma@mtmarchetti.com  
<http://www.mtmarchetti.com>

PRODUZIONE MODULI ROTANTI



PAGINA DW 0453-3-00

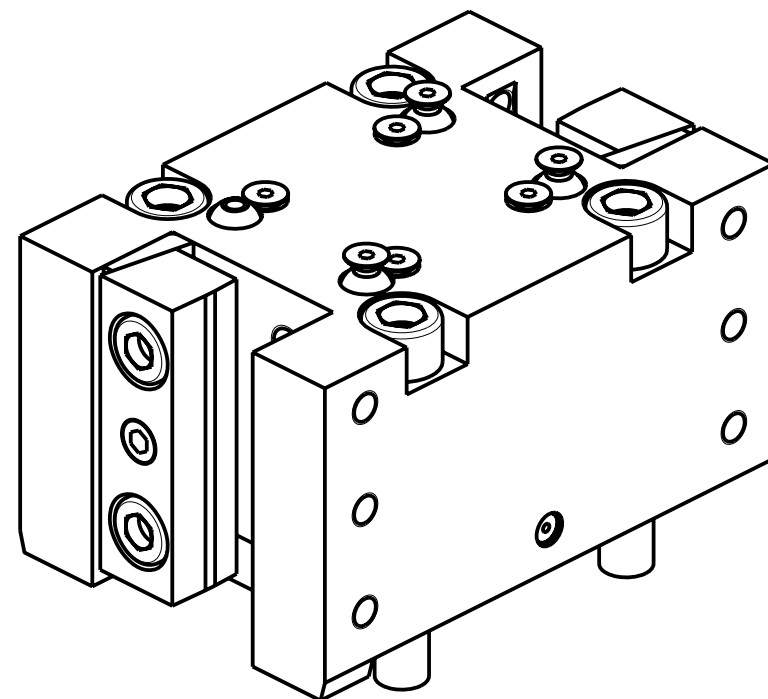
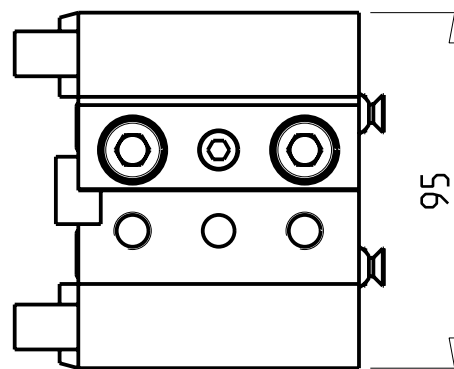
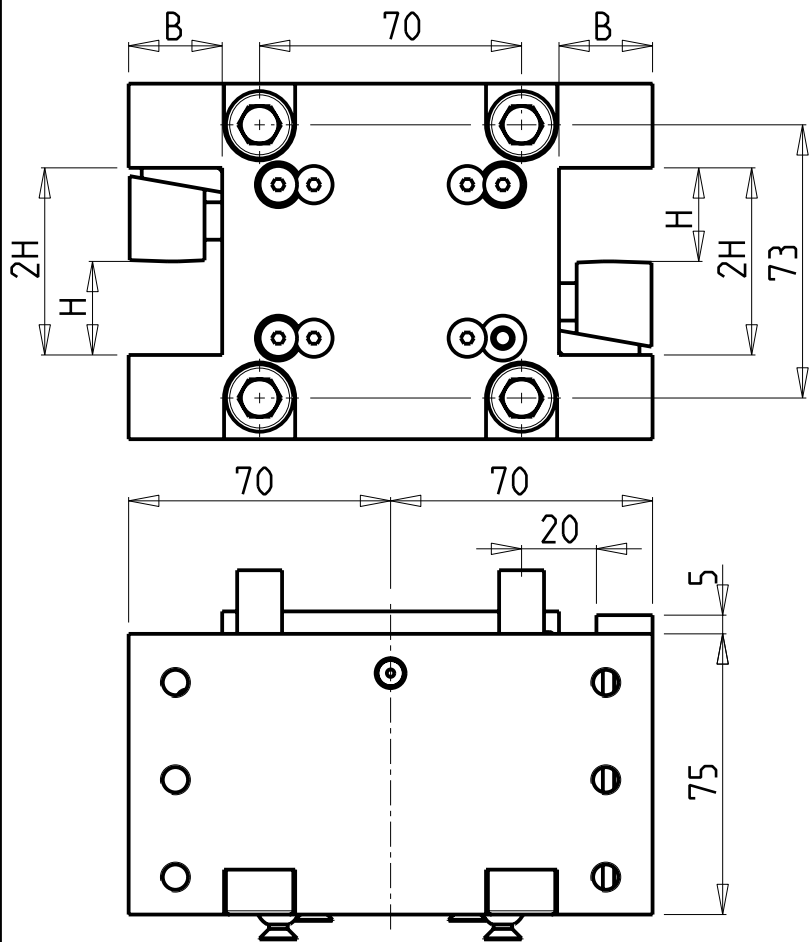

Cod. MT	N°Utensili N°Tools N°Werkzeuge	Reversibile lato mandrino/contromandrino Reversible sub/main spindle side Umkehrbare Spindelseite/ Gegenspindelseite	Misure Dimensions Masse	B	H
DW 00672500	2/4	X	mm	25	25

## DOOSAN BMT 65

MOD: PUMA 300M/MS - V400M - TT2000SY-TT2500SY-TT2500MS - PUMA 2600/3100 SERIE  
MX2000ST - MX2500LT/ST/LST - MX2600T-ST - VT 450M/TM - PUMA INVERTURN 3000M

PORTAUTENSILE RADIALE DOPPIO H=75mm

Radial double static tool H=75mm

Radial Doppel-Werkzeughalter H=75mm

## M.T. srl

Via Casino Albini 480  
Tel. 0541/956034-957884  
Fax 0541/956341  
47842 S. GIOVANNI IN M. (RN)  
e-mail: mtma@mtmarchetti.com  
http://www.mtmarchetti.com

PRODUZIONE MODULI ROTANTI



PAGINA DW 0453-3-10

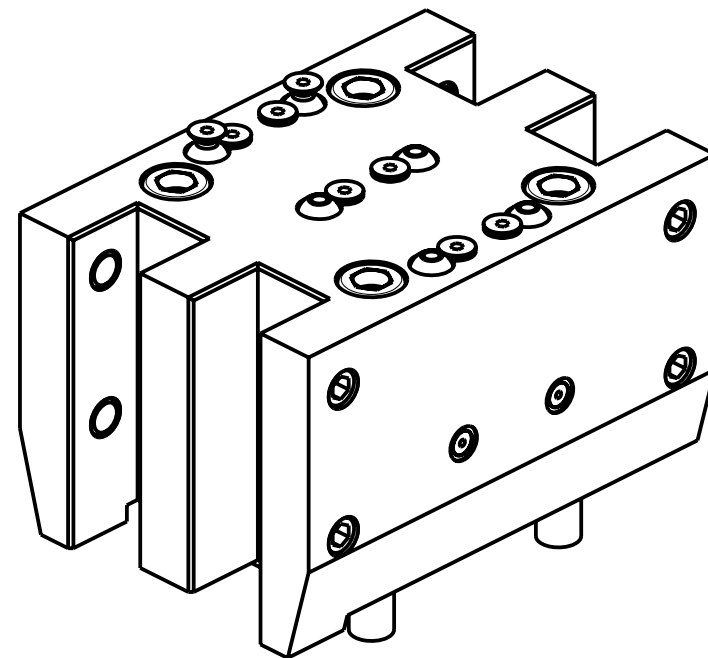
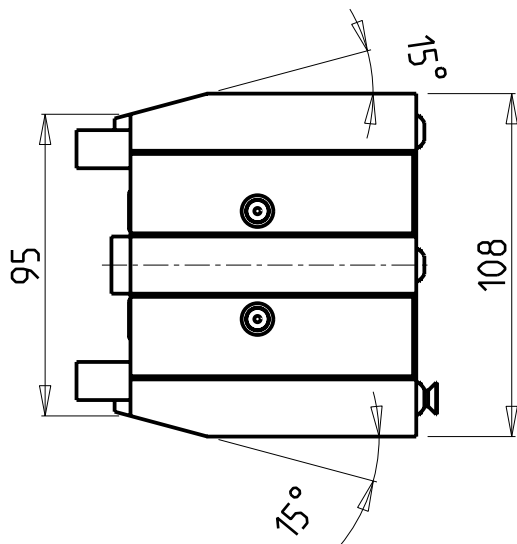
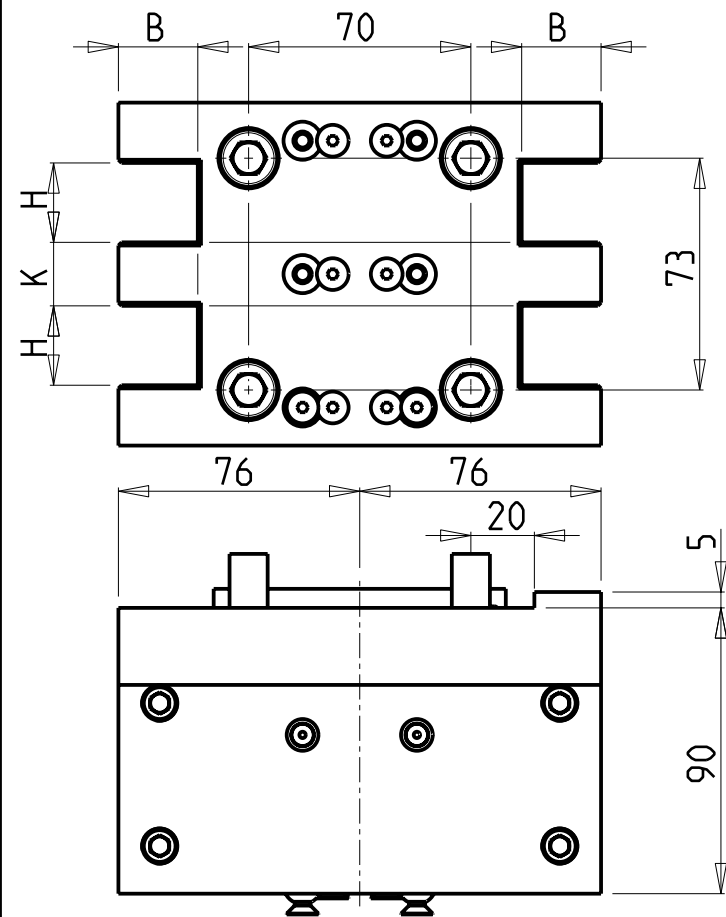

Cod. MT	N°Utensili N°Tools N°Werkzeuge	Reversibile lato mandrino/contromandrino Reversible sub/main spindle side Umkehrbare Spindel-seite/ Gegenspindel-seite	Misure Dimensions Masse	H	K	B
DW 00622500	4	X	mm	25	20	25
DW 00622540	4	X	inch	1"	3/4"	1"

DOOSAN BMT 65

MOD: TT2000SY-TT2500SY-TT2500MS - PUMA 2600/3100 SERIE

PORTAUTENSILE RADIALE DOPPIO SOVRAPPOSTO

Radial double side twin static tool

Radial Doppel-Werkzeughalter ueberlagert

**M.T. srl**

Via Casino Albini 480  
Tel. 0541/956034-957884  
Fax 0541/956341  
47842 S. GIOVANNI IN M. (RN)  
e-mail: mtma@mtmarchetti.com  
http://www.mtmarchetti.com

PRODUZIONE MODULI ROTANTI



PAGINA DW 0463-3-00



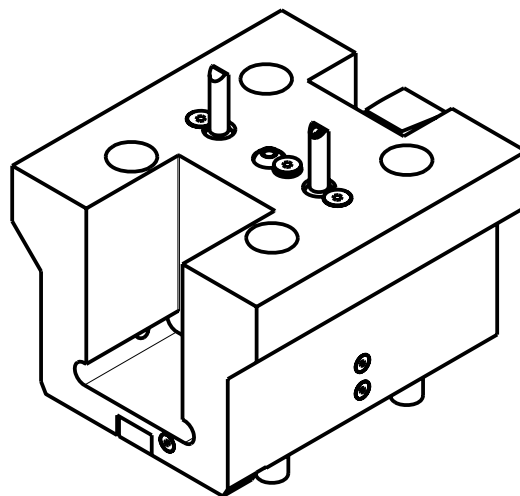
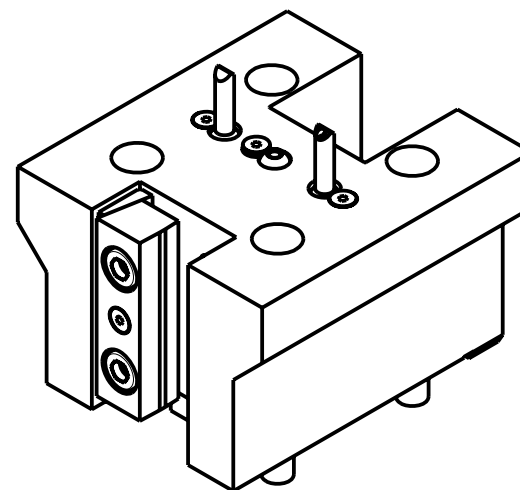
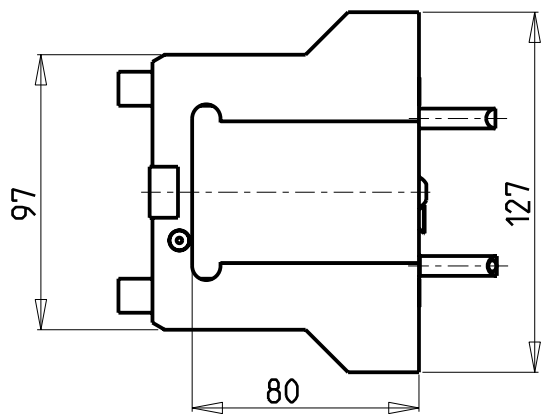
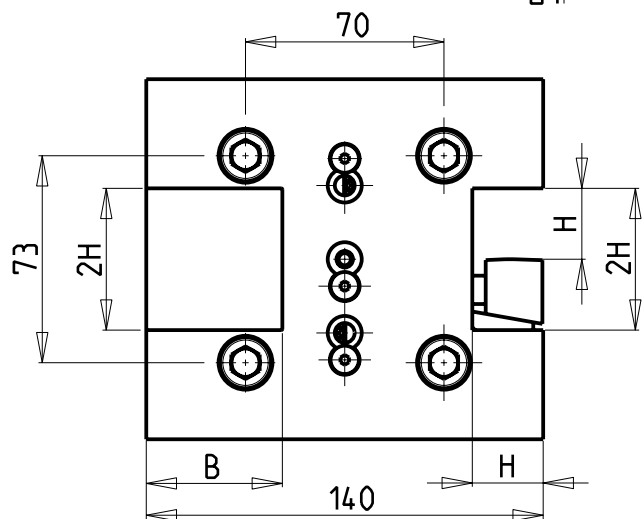
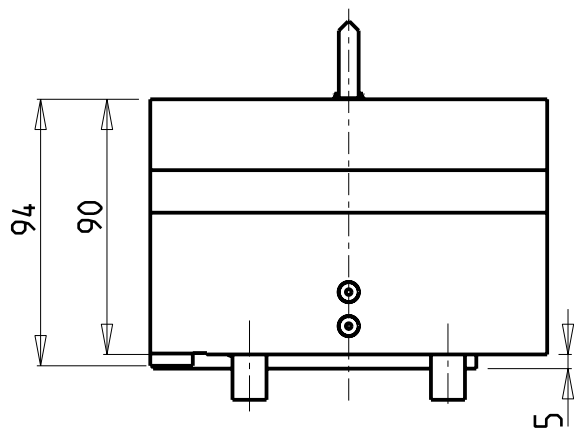

Cod. MT	N°Utensili N°Tools N°Werkzeuge	Reversibile lato mandrino/contromandrino Reversible sub/main spindle side Umkehrbare Spindel-seite/ Gegenspindel-seite	Misure Dimensions Masse	H	B
0875000	2	X	mm	25	48

## DOOSAN BMT 65

MOD: PUMA 300M/MS - V400M - TT2000SY-TT2500SY-TT2500MS - PUMA 2600/3100 SERIE  
MX2000ST - MX2500LT/ST/LST - MX2600T-ST - VT 450M/TM - PUMA INVERTURN 3000M

PORTAUTENSILE RADIALE DOPPIO CON SEDE ATTACCO COROMANT CAPTO®

Radial double static tool with seat for Coromant Capto® connection

Radial Doppel-Werkzeughalter mit Sitz fuer Coromant Capto® Anschluss

**M.T. srl**

Via Casino Albini 480  
Tel. 0541/956034-957884  
Fax 0541/956341  
47842 S. GIOVANNI IN M. (RN)  
e-mail: mtma@mtmarchetti.com  
<http://www.mtmarchetti.com>

PRODUZIONE MODULI ROTANTI



PAGINA DW 0495-3-00

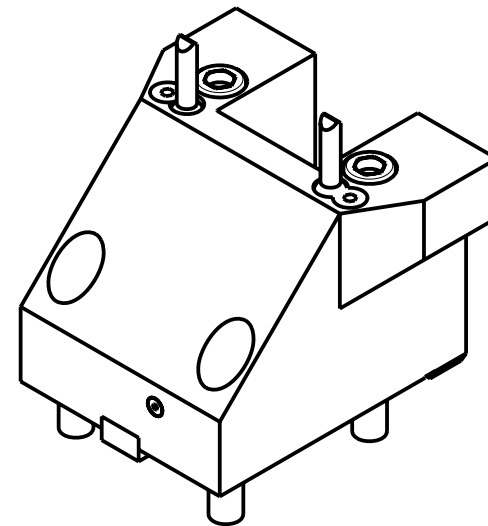
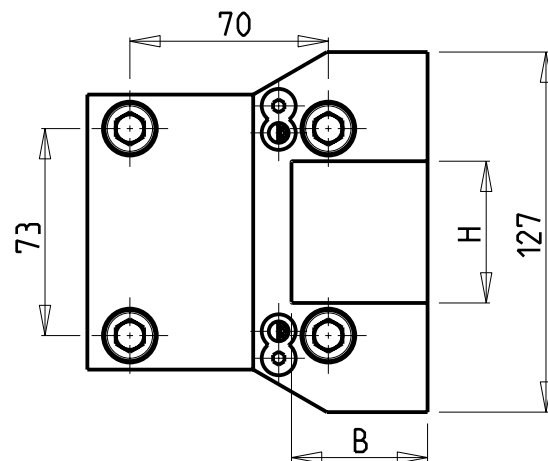
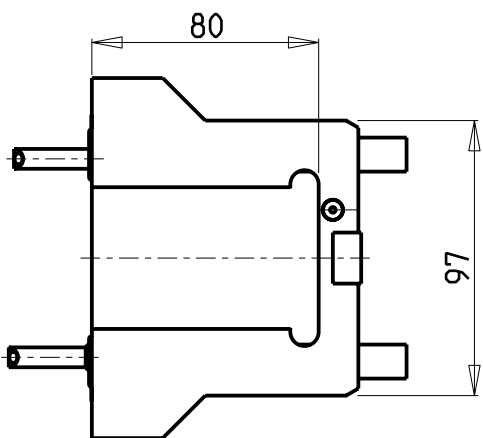
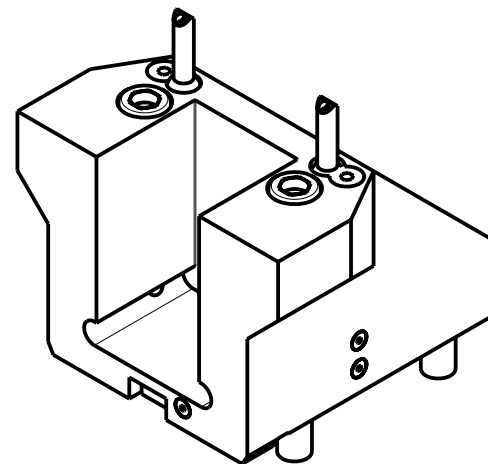
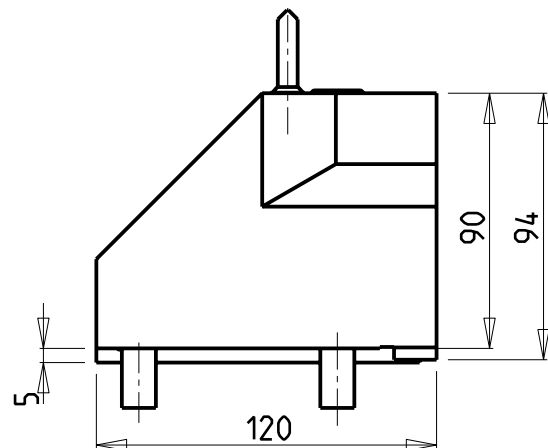

Cod. MT	N°Utensili N°Tools N°Werkzeuge	Reversibile lato mandrino/contromandrino Reversible sub/main spindle side Umkehrbare Spindel-seite/ Gegenspindel-seite	Misure Dimensions Masse	H	B
0885000	1	X	mm	50	48

## DOOSAN BMT 65

MOD: PUMA 300M/MS - V400M - TT2000SY-TT2500SY-TT2500MS - PUMA 2600/3100 SERIE  
MX2000ST - MX2500LT/ST/LST - MX2600T-ST- VT 450M/TM - PUMA INVERTURN 3000M

PORTAUTENSILE RADIALE CON SEDE ATTACCO COROMANT CAPTO®

Radial tool with seat for Coromant Capto® connection

Radial Single-Werkzeughalter mit Sitz fuer Coromant Capto® Anschluss

**M.T. srl**

Via Casino Albini 480  
Tel. 0541/956034-957884  
Fax 0541/956341  
47842 S. GIOVANNI IN M. (RN)  
e-mail: mtma@mtmarchetti.com  
<http://www.mtmarchetti.com>

PRODUZIONE MODULI ROTANTI



PAGINA DW 0500-3-00

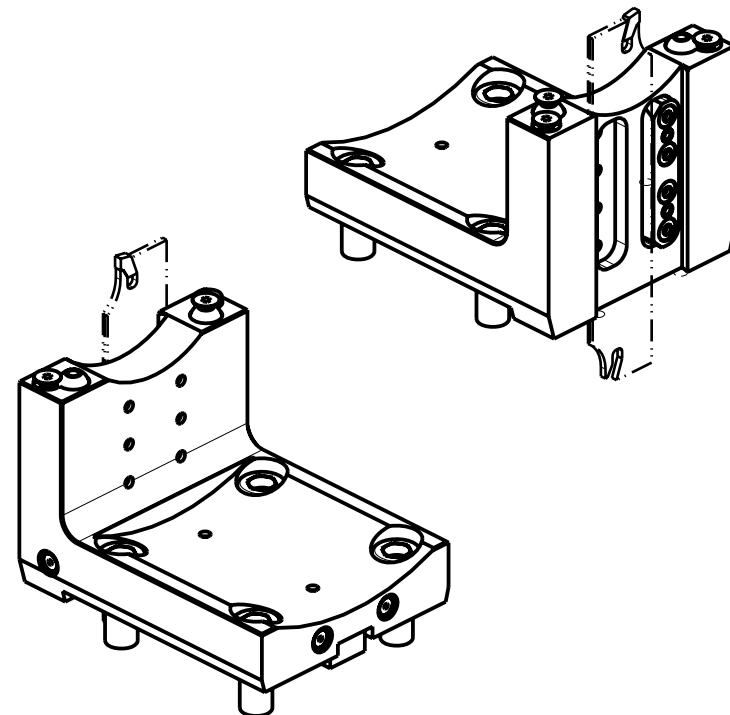
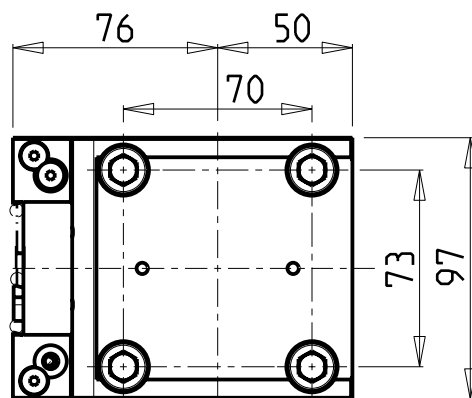
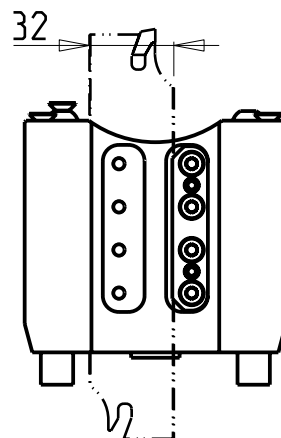
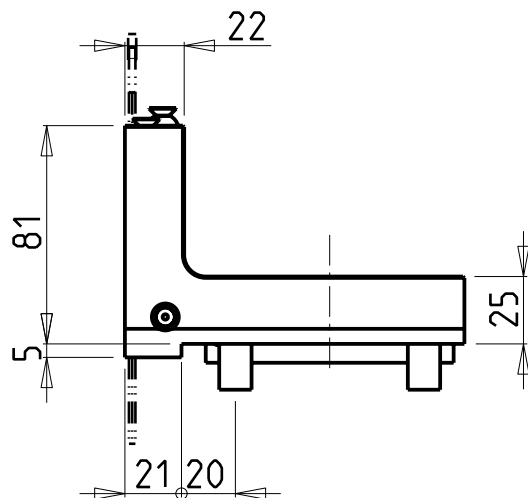
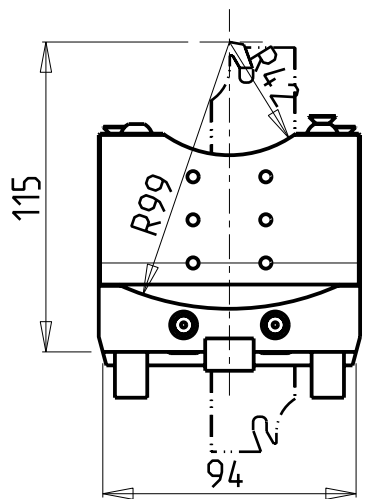

POSSIBILITA' DI LAVORO M3/M4  
 OPTION OF M3/M4 WORKING  
 ARBEITSMOEGlichkeit M3/M4

**DOTAZIONI - SUPPLIED WITH - AUSSTATTUNG**

- N°1 - LAMA - BLADE - KLINGE ISCAR H=32 Sp. 3/4mm (KENNAMETAL OPTIONAL)
- N°10 - INSERTI - INSERTS - EINLAGEN
- N°1 - CHIAVE A T PER MONTAGGIO INSERTI  
 - T-WRENCH FOR INSERT SET UP  
 - T-SCHLUESSEL FUER EINSATZSTUECK-MONTAGE

Cod. MT	N°Utensili N°Tools N°Werkzeuge	Reversibile lato mandrino/contromandrino Reversible sub/main spindle side Umkehrbare Spindelseite/ Gegenspindelseite	Lubr.esterna Ext. coolant Aussenkuehlung
DW 00690132	1	X	X

NEW

**DOOSAN BMT 65**

MOD: PUMA 300M/MS - V400M - TT2000SY-TT2500SY-TT2500MS - PUMA 2600/3100 SERIE  
 MX2000ST - MX2500LT/ST/LST - MX2600T-ST - VT 450M/TM

PORTAUTENSILE RADIALE PER LAMA

Radial blade holder

Radial Abstechhalter

**M.T. srl**

Via Casino Albini 480  
 Tel. 0541/956034-957884  
 Fax 0541/956341  
 47842 S. GIOVANNI IN M. (RN)  
 e-mail: mtma@mtmarchetti.com  
 http://www.mtmarchetti.com

PRODUZIONE MODULI ROTANTI



PAGINA DW 0510-3-00

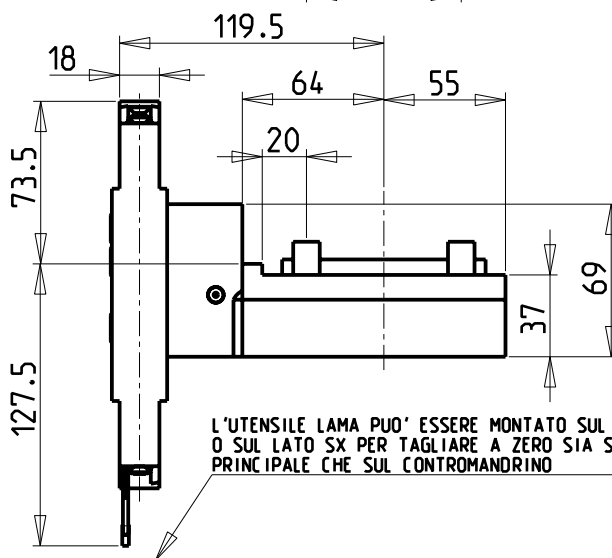
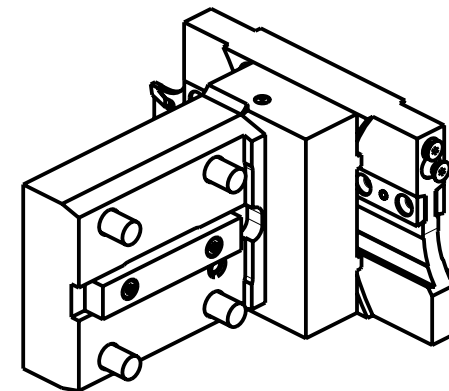
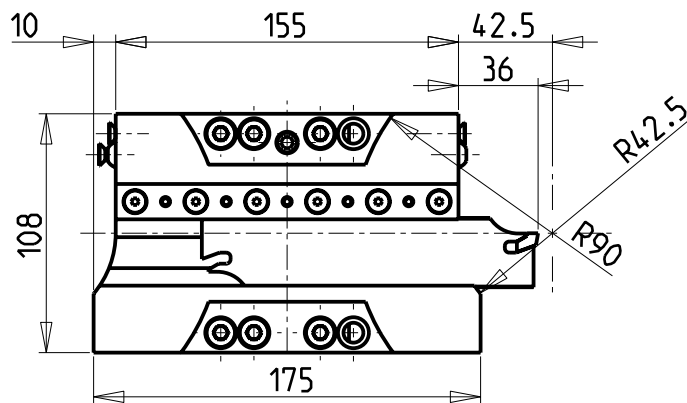
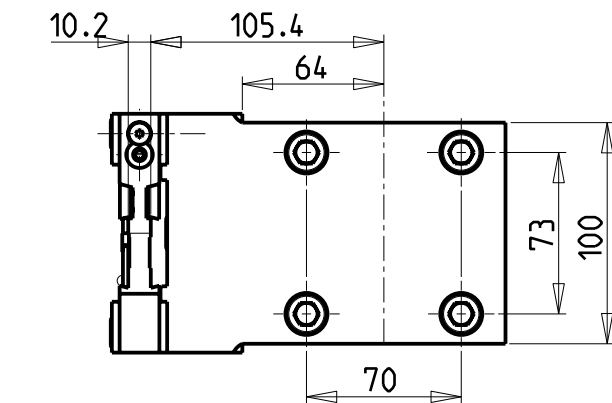

L'UTENSILE LAMA PUO' ESSERE MONTATO SUL LATO DX  
O SUL LATO SX PER TAGLIARE A ZERO SIA SUL MANDRINO  
PRINCIPALE CHE SUL CONTROMANDRINO

POSSIBILITA' DI LAVORO M3/M4  
OPTION OF M3/M4 WORKING  
ARBEITSMÖGLICHKEIT M3/M4

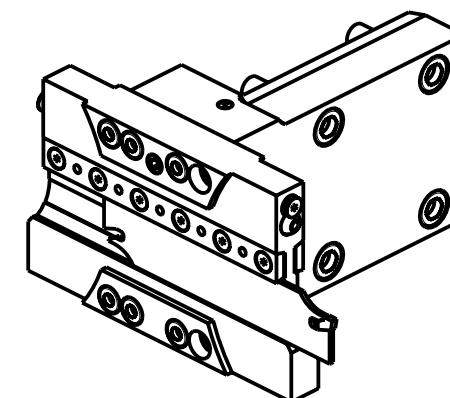

ATTENZIONE - ATTENTION - ACHTUNG

- FINO AD ESAURIMENTO SCORTE
- clearance sale
- solange vorrat

**DOTAZIONI - SUPPLIED WITH - AUSSTATTUNG**

- N°1 - LAMA - BLADE - KLINGE ISCAR H=32 Sp. 3/4mm (KENNAMETAL OPTIONAL)
- N°10 - INSERTI - INSERTS - EINLAGEN
- N°1 - CHIAVE A T PER MONTAGGIO INSERTI  
- T-WRENCH FOR INSERT SET UP  
- T-SCHLUESSEL FUER EINSATZSTUECK-MONTAGE

Cod. MT

N°Utensili  
N°Tools  
N°Werkzeuge

DW 00120132

1

**DOOSAN BMT 65**

MOD: PUMA 300M/MS - V400M - TT2000SY-TT2500SY-TT2500MS - PUMA 2600/3100 SERIE  
MX2000ST - MX2500LT/ST/LST - MX2600T-ST - VT 450M/TM

PORTAUTENSILE PER LAMA DOPPIO

Radial double blade holder

Radial Doppel-Abstechhalter

**M.T. srl**

Via Casino Albini 480  
Tel. 0541/956034-957884  
Fax 0541/956341  
47842 S. GIOVANNI IN M. (RN)  
e-mail: mtma@mtmarchetti.com  
http://www.mtmarchetti.com

PRODUZIONE MODULI ROTANTI



PAGINA DW 0520-3-00

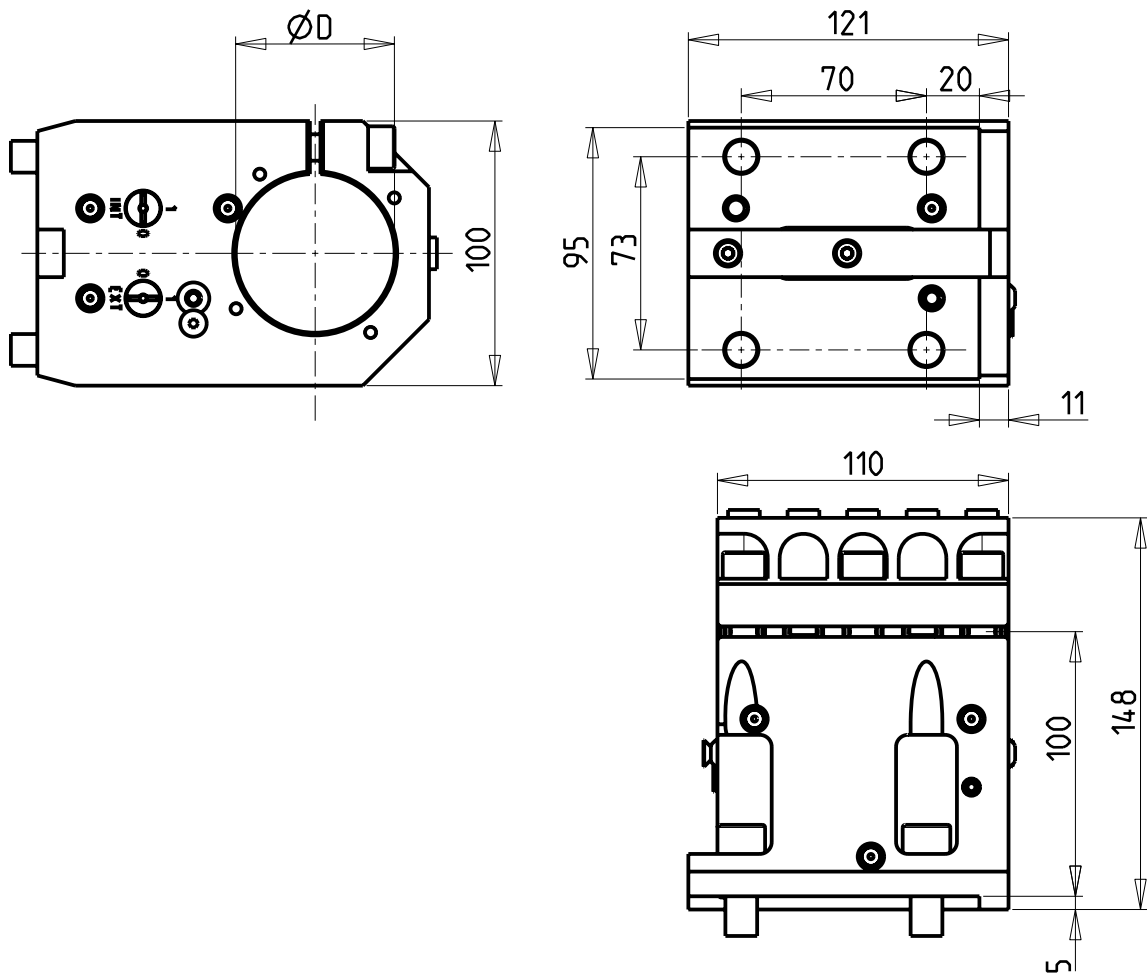

KIT ADDUZIONE INTERNA (OPZIONALE)  
 KIT FOR INTERNAL COOLANT (OPTIONAL)  
 KIT FÜR INTERNE KUEHLMITTELZUFUHR (OPTIONAL)  
 Ø60 cod. KIT1003025

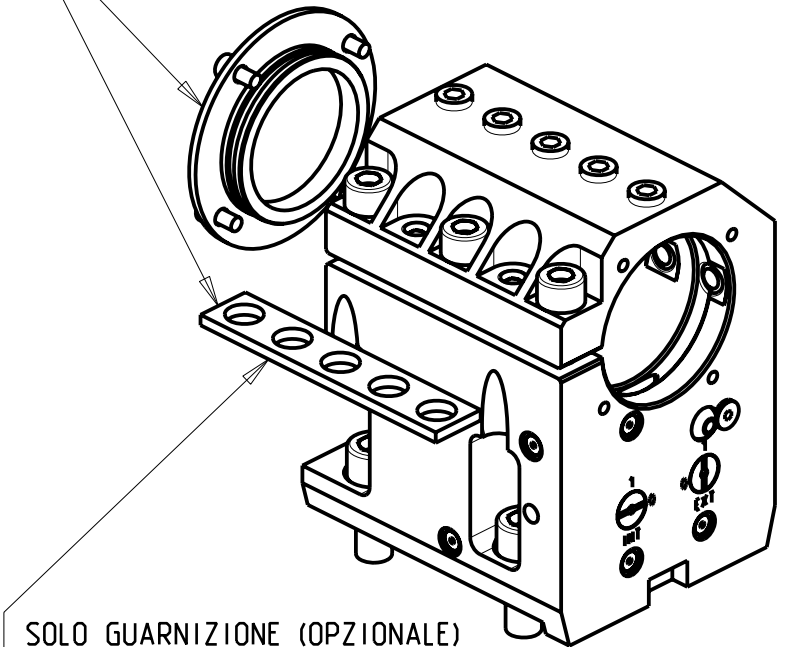

SOLO GUARNIZIONE (OPZIONALE)  
 ONLY SEAL (OPTIONAL) NUR  
 DICHTUNG (OPTIONAL) cod.  
 0520013

PER BOCCOLE DI RIDUZIONE VEDI PAG. TBL150-1-00  
 FOR REDUCING BUSHINGS SEE PAGE TBL150-1-00  
 FÜR REDUZIERBUCHSE SIEHE SEITE TBL150-1-00

Cod. MT	N°Utensili N°Tools N°Werkzeuge	Reversibile lato mandrino/contromandrino Reversible sub/main spindle side Umkehrbare Spindel-seite/ Gegenspindel-seite	Lubrificazione int. opzionale Coolant through optional Innenkuehlung Optional	Lubrificazione est. Ext. coolant Aussenkuehlung	Misure Dimensions Masse	D
DW00746000	1	X	X	X	mm	60

NEW

## DOOSAN BMT 65

MOD: TT2000SY-TT2500SY-TT2500MS - PUMA 2600/3100 SERIE - MX2000ST - MX2500LT/ST/LST - MX2600T-ST - VT 450M/TM

PORTAUTENSILE ASSIALE PER BARENO Ø60mm H=100mm

Axial single boring bar holder Ø60mm H=100mm

Axial Bohrhälter Ø60mm H=100mm

**M.T. srl**

Via Casino Albini 480  
 Tel. 0541/956034-957884  
 Fax 0541/956341  
 47842 S. GIOVANNI IN M. (RN)  
 e-mail: mtma@mtmarchetti.com  
 http://www.mtmarchetti.com

PRODUZIONE MODULI ROTANTI



PAGINA DW 0590-3-20

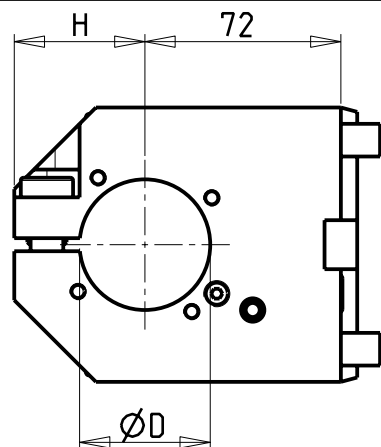
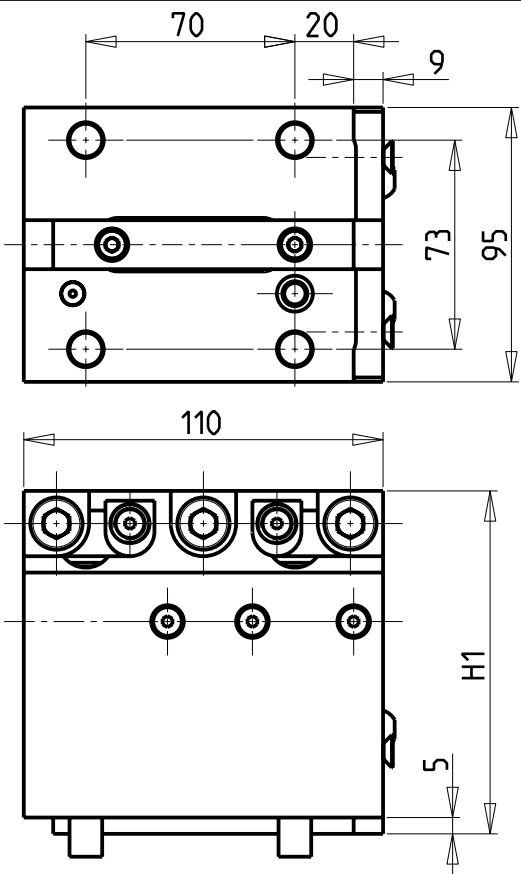

KIT ADDUZIONE INTERNA (OPZIONALE)  
 KIT FOR INTERNAL COOLANT (OPTIONAL)  
 KIT FUER INTERNE KUEHLMITTELZUFUHR (OPTIONAL)  
 Ø1 1/2" cod. KIT1003004  
 Ø40 cod. KIT1003003  
 Ø50-Ø2" cod. KIT1003002

SOLO GUARNIZIONE (OPZIONALE)  
 ONLY SEAL (OPTIONAL)  
 NUR DICHTUNG (OPTIONAL)  
 cod. 0520013

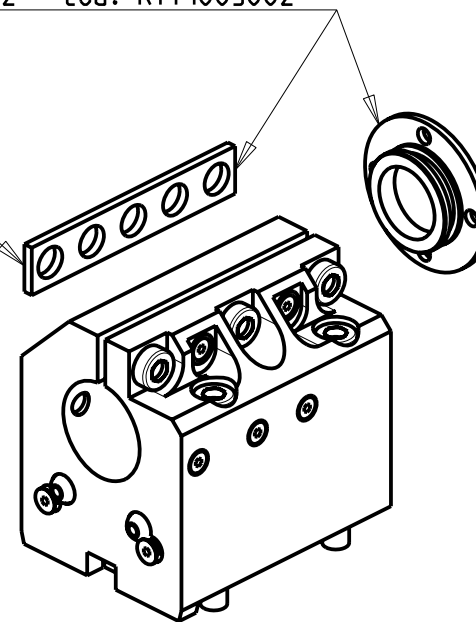

PER BOCCOLE DI RIDUZIONE VEDI PAG. TBL150-1-00  
 FOR REDUCING BUSHINGS SEE PAGE TBL150-1-00  
 FÜR REDUZIERBUCHSE SIEHE SEITE TBL150-1-00

Cod. MT	N°Utensili N°Tools N°Werkzeuge	Reversibile lato mandrino/contromandrino Reversible sub/main spindle side Umkehrbare Spindel-seite/ Gegenspindel-seite	Lubrificazione int. opzionale Coolant through optional Innenkuehlung Optional	Lubrificazione est. Ext. coolant Aussenkuehlung	Misure Dimensions Masse	D	H	H1
0834000	1	X	X	X	mm	40	40	117.5
0833810	1	X	X	X	Inch	1 1/2"	40	117.5
0835000	1	X	X	X	mm	50	46.5	123.5
0835080	1	X	X	X	Inch	2"	46.5	123.5

## DOOSAN BMT 65

MOD: PUMA 300M/MS - V400M - TT2000SY-TT2500SY-TT2500MS - PUMA 2600/3100 SERIE  
 MX2000ST - MX2500LT/ST/LST - VT 450M/TM

PORTAUTENSILE ASSIALE PER BARENO Ø40mm/Ø1 1/2"/Ø50mm/Ø2" H=72mm

Axial single boring bar holder Ø40mm/Ø1 1/2"/Ø50mm/Ø2" H=72mm

Axial Bohrhälter Ø40mm/Ø1 1/2"/Ø50mm/Ø2" H=72mm

## M.T. srl

Via Casino Albini 480  
 Tel. 0541/956034-957884  
 Fax 0541/956341  
 47842 S. GIOVANNI IN M. (RN)  
 e-mail: mtma@mtmarchetti.com  
 http://www.mtmarchetti.com

PRODUZIONE MODULI ROTANTI



PAGINA DW 0610-3-20

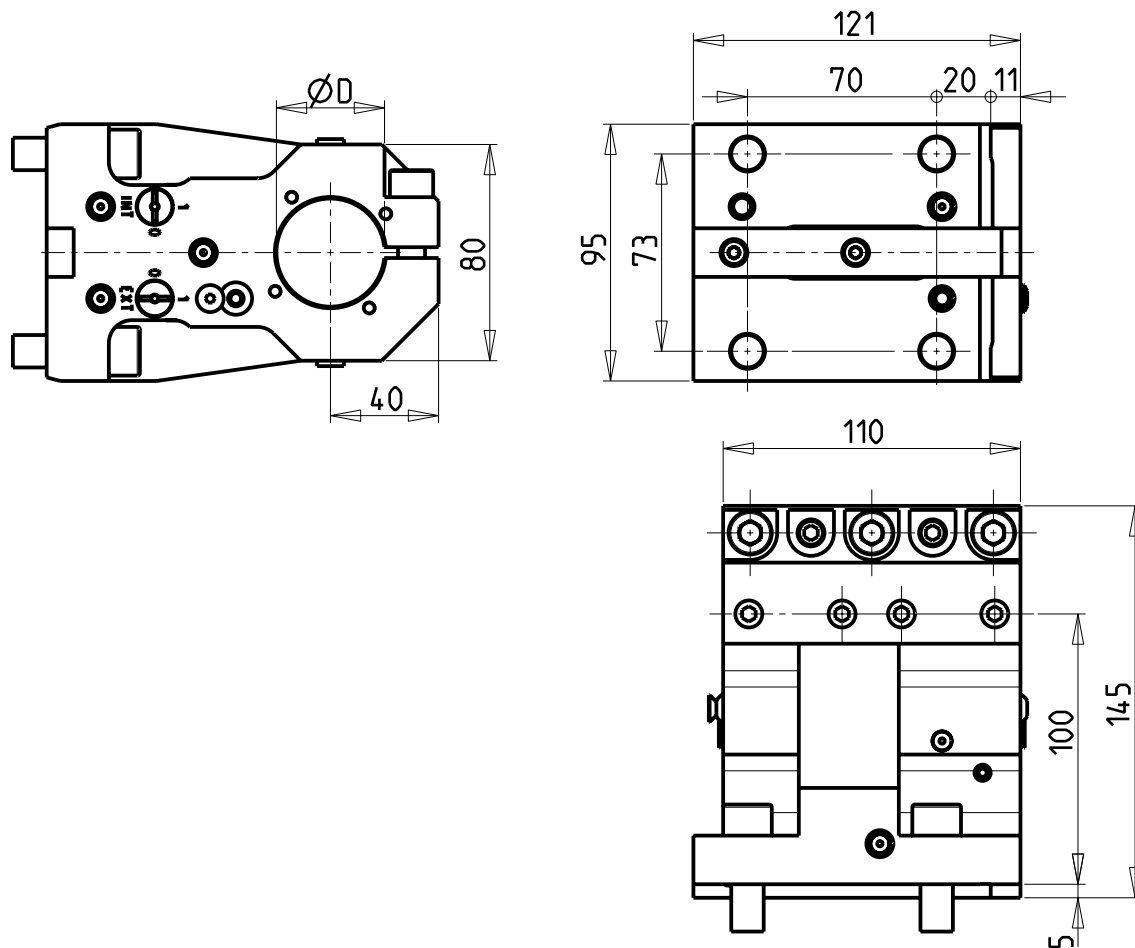

KIT ADDUZIONE INTERNA (OPZIONALE)  
 KIT FOR INTERNAL COOLANT (OPTIONAL)  
 KIT FUER INTERNE KUEHLMITTELZUFUHR (OPTIONAL)  
 Ø40 cod. KIT1003003

SOLO GUARNIZIONE (OPZIONALE)  
 ONLY SEAL (OPTIONAL)  
 NUR DICHTUNG (OPTIONAL)  
 cod. 0520013

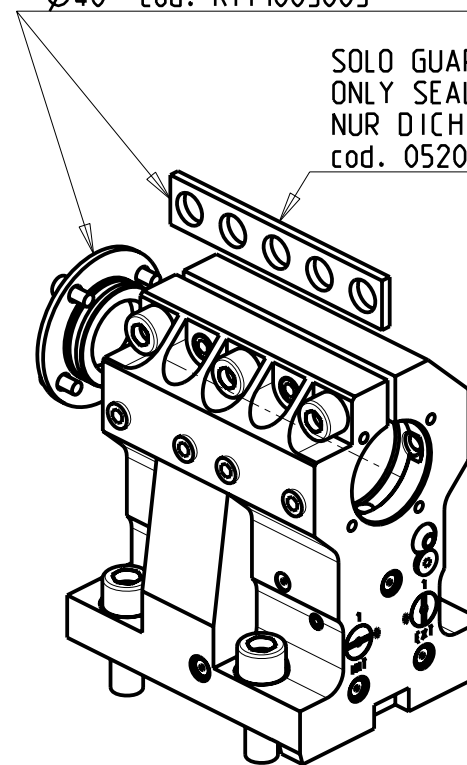

PER BOCCOLE DI RIDUZIONE VEDI PAG. TBL150-1-00  
 FOR REDUCING BUSHINGS SEE PAGE TBL150-1-00  
 FÜR REDUZIERBUCHSE SIEHE SEITE TBL150-1-00

Cod. MT	N°Utensili N°Tools N°Werkzeuge	Reversibile lato mandrino/contromandrino Reversible sub/main spindle side Umkehrbare Spindel-seite/ Gegenspindel-seite	Lubrificazione int. opzionale Coolant through optional Innenkuehlung Optional	Lubrificazione est. Ext. coolant Aussenkuehlung	Misure Dimensions Masse	D
DW00204000	1	X	X	X	mm	40

DOOSAN BMT 65

MOD: TT2000SY-TT2500SY-TT2500MS - PUMA 2600/3100 SERIE - MX2000ST - MX2500LT/ST/LST - MX2600T-ST - VT 450M/TM

PORTAUTENSILE ASSIALE PER BARENO Ø40mm H=100mm

Axial single boring bar holder Ø40mm H=100mm

Axial Bohrhälter Ø40mm H=100mm

**M.T. srl**

Via Casino Albini 480  
 Tel. 0541/956034-957884  
 Fax 0541/956341  
 47842 S. GIOVANNI IN M. (RN)  
 e-mail: mtma@mtmarchetti.com  
 http://www.mtmarchetti.com

PRODUZIONE MODULI ROTANTI



PAGINA DW0640-3-20

KIT ADDUZIONE INTERNA (OPZIONALE)  
 KIT FOR INTERNAL COOLANT (OPTIONAL)  
 KIT FUER INTERNE KUEHLMITTELZUFUHR (OPTIONAL)  
 cod. KIT1000001

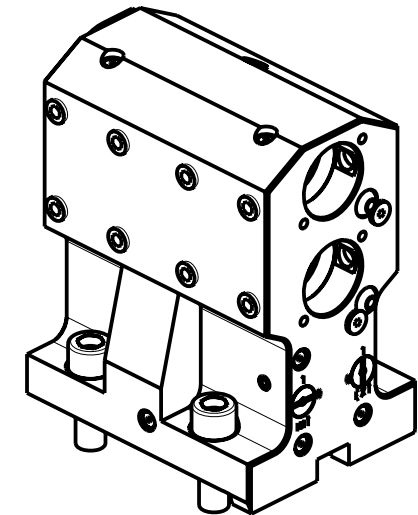
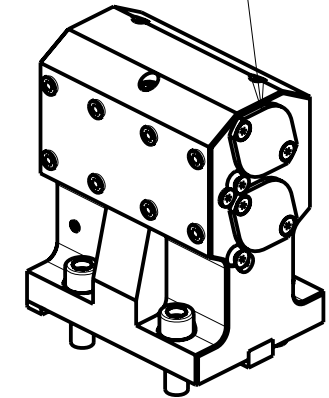
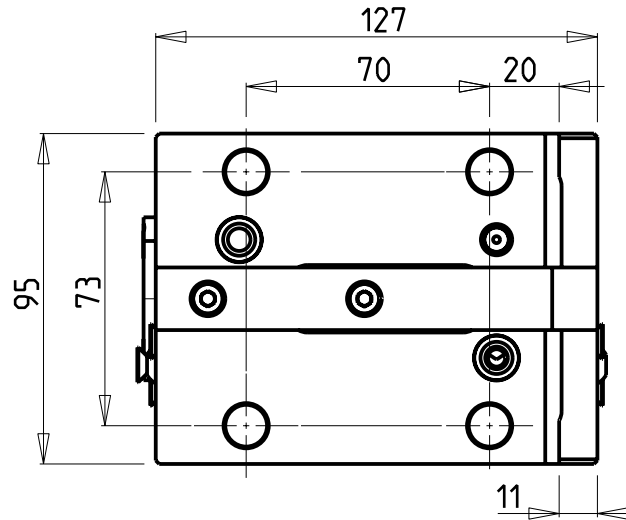
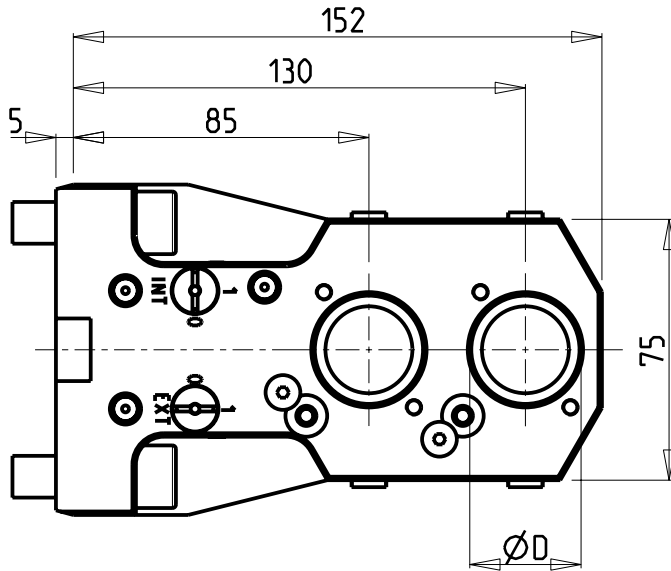

PER BOCCOLE DI RIDUZIONE VEDI PAG. TBL150-1-00  
 FOR REDUCING BUSHINGS SEE PAGE TBL150-1-00  
 FÜR REDUZIERBUCHSE SIEHE SEITE TBL150-1-00

Cod. MT	N°Utensili N°Tools N°Werkzeuge	Reversibile lato mandrino/contromandrino Reversible sub/main spindle side Umkehrbare Spindel-seite/ Gegenspindel-seite	Lubrificazione int. opzionale Coolant through optional Innenkuehlung Optional	Lubrificazione est. Ext. coolant Aussenkuehlung	Misure Dimensions Masse	D
DW 00213200	2+2	X	X	X	mm	32
DW 00213175	2+2	X	X	X	Inch	1 1/4"

NEW

DOOSAN BMT 65

MOD: V400M - TT2000SY-TT2500SY-TT2500MS - PUMA 2600/3100 SERIE  
 MX2000ST - MX2500LT/ST/LST - VT 450M/TM

PORTAUTENSILE ASSIALE PER BARENO 2 POSIZIONI Ø32mm / Ø1 1/4"

Axial double boring bar holder Ø32mm / Ø1 1/4"

Axial Bohrhälter 2 Positionen Ø32mm / Ø1 1/4"

**M.T. srl**

Via Casino Albini 480  
 Tel. 0541/956034-957884  
 Fax 0541/956341  
 47842 S. GIOVANNI IN M. (RN)  
 e-mail: mtma@mtmarchetti.com  
 http://www.mtmarchetti.com

PRODUZIONE MODULI ROTANTI



PAGINA DW 0862-3-00



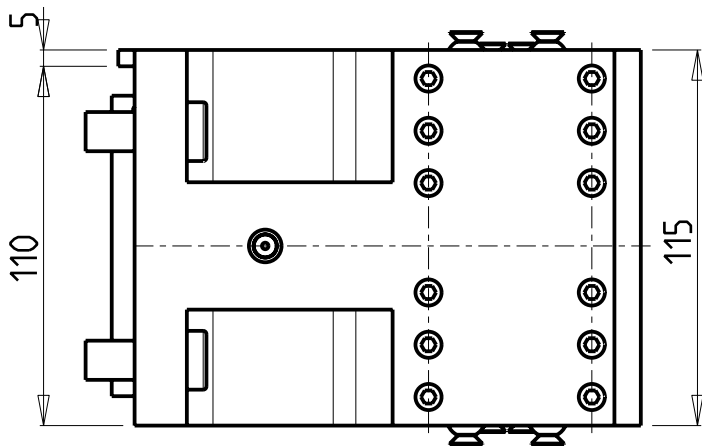
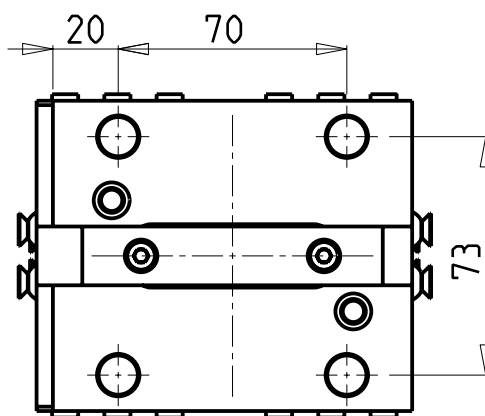
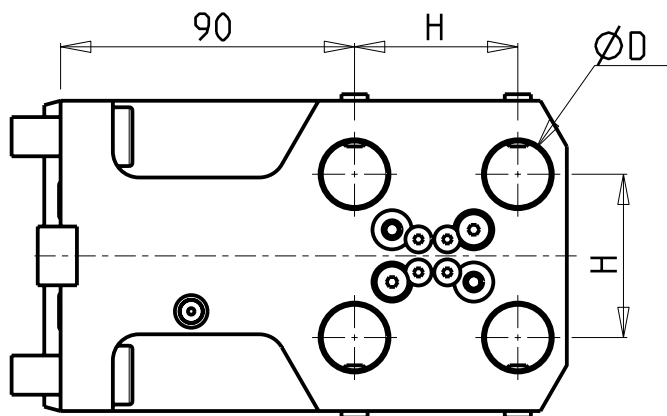

### DOTAZIONI - SUPPLIED WITH - AUSSTATTUNG

mm	N°5 Boccole - Bushings - Buchsen Ø16-12-10-8-6 N°1 ER16 Portapinza - Collet holder - Zangenhalter N°1 ER25 Portapinza - Collet holder - Zangenhalter
inch	N°3 Boccole - Bushings - Buchsen Ø1/2"-3/8"-1/4" N°1 ER16 Portapinza - Collet holder - Zangenhalter N°1 ER25 Portapinza - Collet holder - Zangenhalter

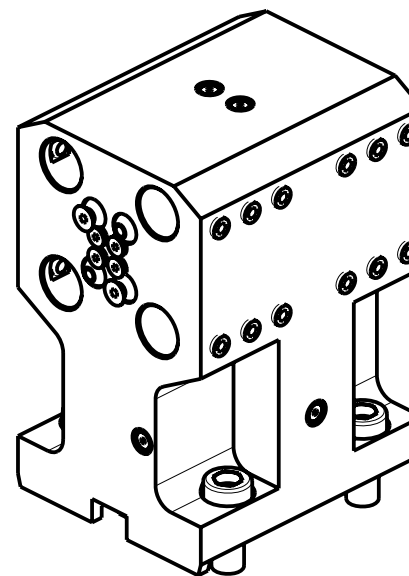

Cod. MT	N°Utensili N°Tools N°Werkzeuge	Reversibile lato mandrino/contromandrino Reversible sub/main spindle side Umkehrbare Spindel-seite/ Gegenspindel-seite	Lubrificazione est. Ext. coolant Aussenkuehlung	Misure Dimensions Masse	D	H
DW 00632000	4+4	X	X	mm	20	48
DW 00631905	4+4	X	X	Inch	3/4"	1 7/8"

DOOSAN BMT 65

MOD: TT2000SY-TT2500SY-TT2500MS - PUMA 2600/3100 SERIE

PORTAUTENSILE ASSIALE PER BARENO 4+4 POSIZIONI Ø20mm/Ø3/4"

Axial 4+4 position boring bar holder Ø20mm/Ø3/4"

Axial Bohrhälter 4+4 Positionen Ø20mm/Ø3/4"

**M.T. srl**

Via Casino Albini 480  
Tel. 0541/956034-957884  
Fax 0541/956341

47842 S. GIOVANNI IN M. (RN)  
e-mail: mtma@mtmarchetti.com  
http://www.mtmarchetti.com

PRODUZIONE MODULI ROTANTI



PAGINA DW 0924-3-00

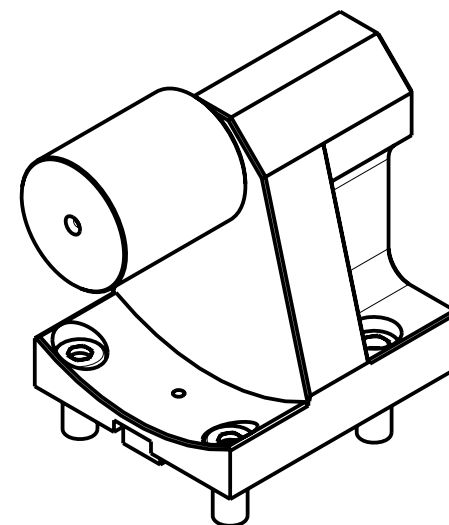
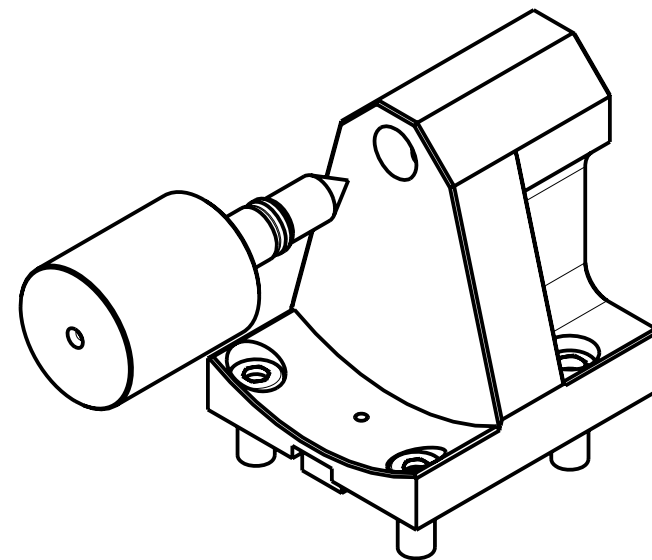
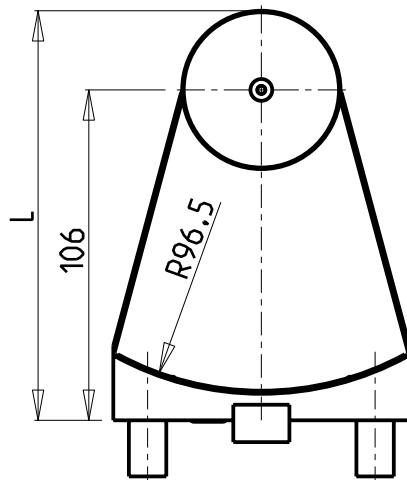
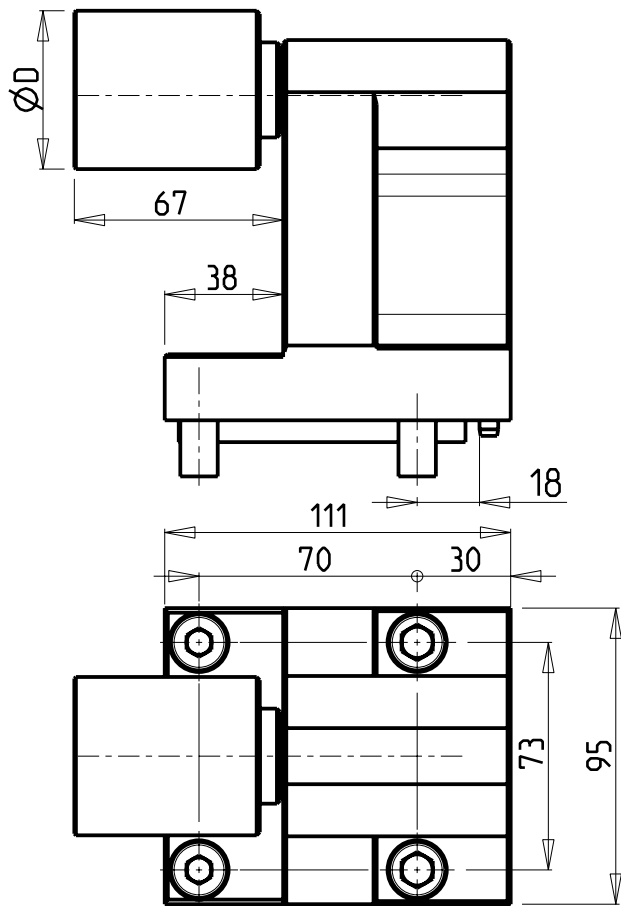

Cod. MT	N°Utensili N°Tools N°Werkzeuge	D	L
0820200	1	38	125
0820200L	1	2"	131.4

## DOOSAN BMT 65

MOD: PUMA 300M/MS - V400M - TT2000SY-TT2500SY-TT2500MS - PUMA 2600/3100 SERIE  
 MX2000ST - MX2500LT/ST/LST - MX2600T-ST - VT 450M/TM

CONTROPUNTA PER CONTROMANDRINO

Tailstock for subspindle

Gegenspitz fuer Gegenspindel

**M.T. srl**

Via Casino Albini 480  
 Tel. 0541/956034-957884  
 Fax 0541/956341  
 47842 S. GIOVANNI IN M. (RN)  
 e-mail: mtma@mtmarchetti.com  
 http://www.mtmarchetti.com

PRODUZIONE MODULI ROTANTI



PAGINA DW0950-3-00

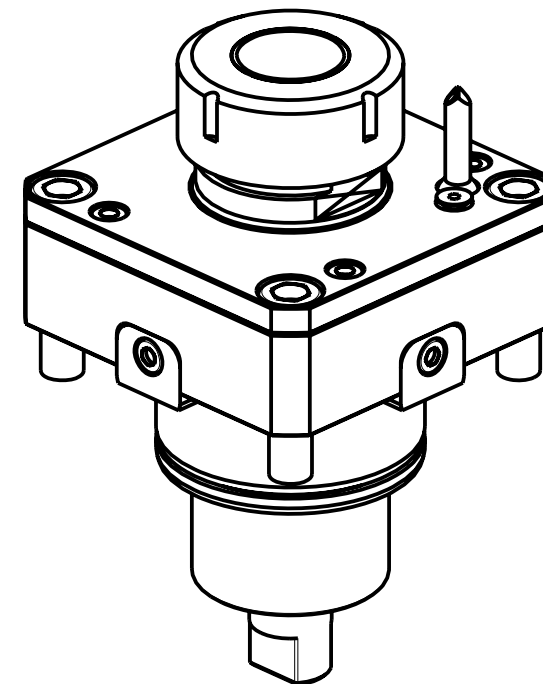
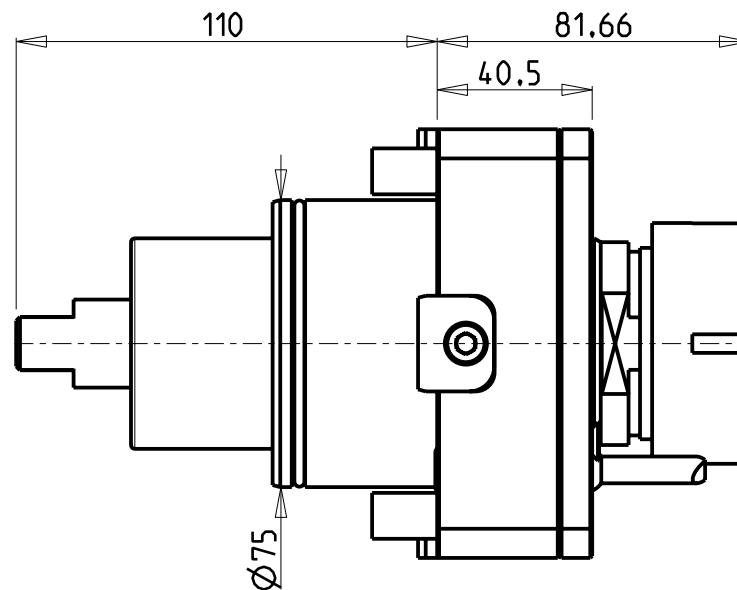
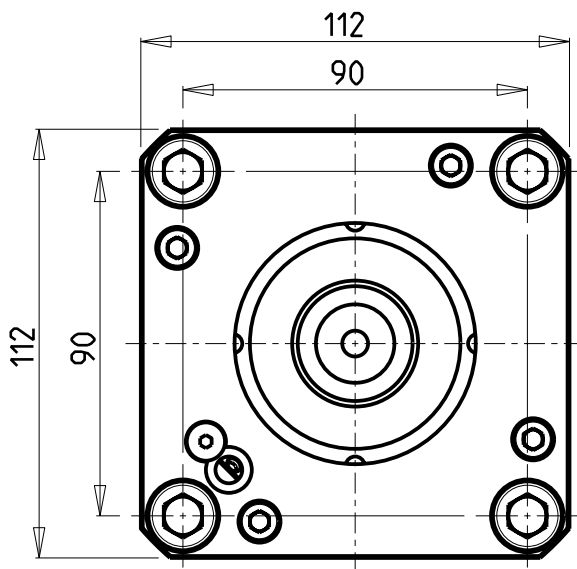

Cod. MT	Cod. EPPINGER	Mandrino Spindle Spindel	I	RPM	Coppia Max Max Torque Max Drehmoment	Lubrificazione int. Coolant through Innenkuehlung	Lubrificazione est. Ext. coolant Aussekuehlung	CHIAVI NON INCLUDE Keys not included Schluessel nicht einbegriffen	
0291540	R78606	ER40	1:1	6000	100Nm		X	CHSTER40	CHUB46 o 0290018
0291040	-	ER40	1:1	6000	100Nm	P=30bar		CHSTER40	CHUB46 o 0290018

DOOSAN BMT 75

MOD: PUMA 400 - PUMA 480M/LM/XLM - VT 750M/TM

MODULO MOTORIZZATO RADIALE

Radial driven tool

Radial angetriebenes Werkzeug

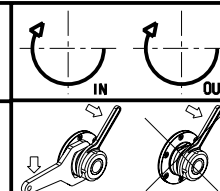

**M.T. srl**

Via Casino Albini 480  
Tel. 0541/956034-957884

Fax 0541/956341

47842 S. GIOVANNI IN M. (RN)

e-mail: mtma@mtmarchetti.com

http://www.mtmarchetti.com

PRODUZIONE MODULI ROTANTI



PAGINA DW 0010-4-00

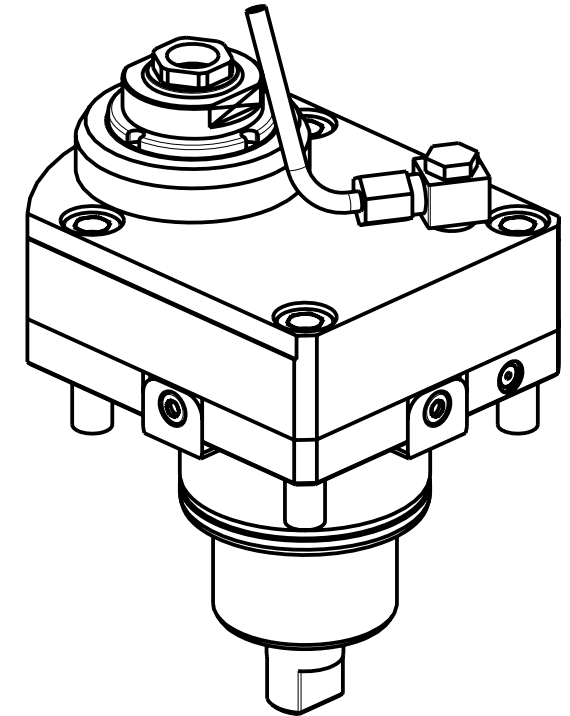
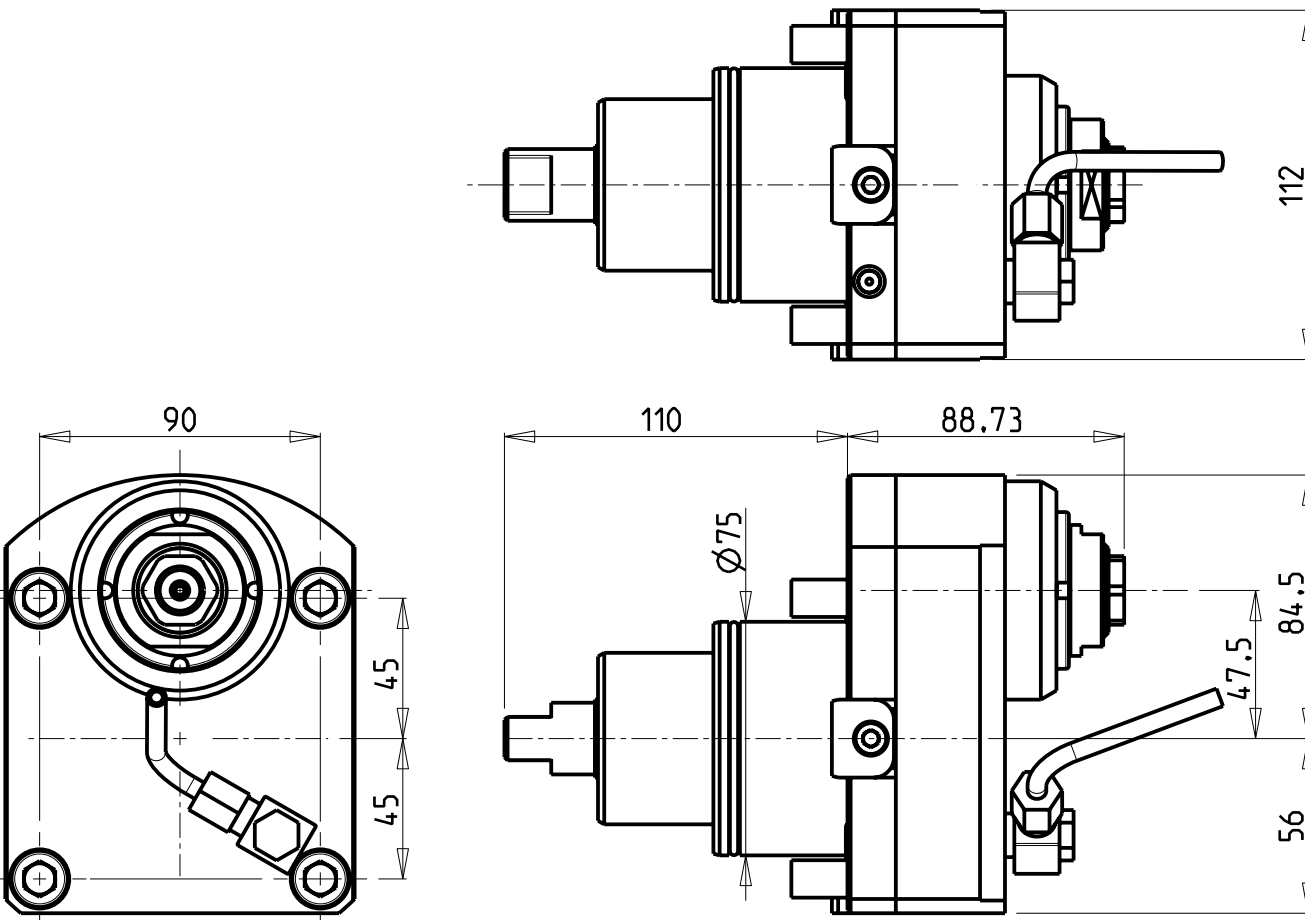

Cod. MT	Mandrino Spindle Spindel	I	RPM	Coppia Max Max Torque Max Drehmoment	Reversibile lato mandrino/contromandrino Reversible sub/main spindle side Umkehrbare Spindel-seite/ Gegenspindel-seite	Lubr. esterna Ext. coolant Aussenkuehlung	CHIAVI NON INCLUSE Keys not included Schluessel nicht einbegriffen
DW00430120	ERA20	1:1	6000	80Nm	X	X	CHUB36 CHUB22

DOOSAN BMT 75  
 MOD: PUMA 400 - PUMA 480M/LM/XLM - VT 750M/TM  
 MODULO MOTORIZZATO RADIALE DISASSATO IN Z 47.5mm  
 Radial driven tool re-directed in Z by 47.5mm  
 Radial angetriebenes Werkzeug achsversetzt in Z um 47.5mm

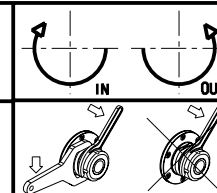

**M.T. srl**  
 Via Casino Albini 480  
 Tel. 0541/956034-957884  
 Fax 0541/956341  
 47842 S. GIOVANNI IN M. (RN)  
 e-mail: mtma@mtmarchetti.com  
 http://www.mtmarchetti.com



PAGINA DW0033-4-10

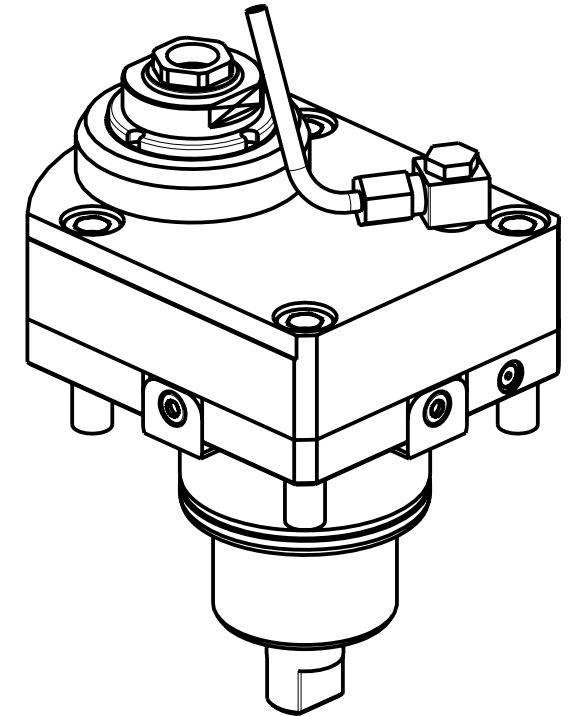
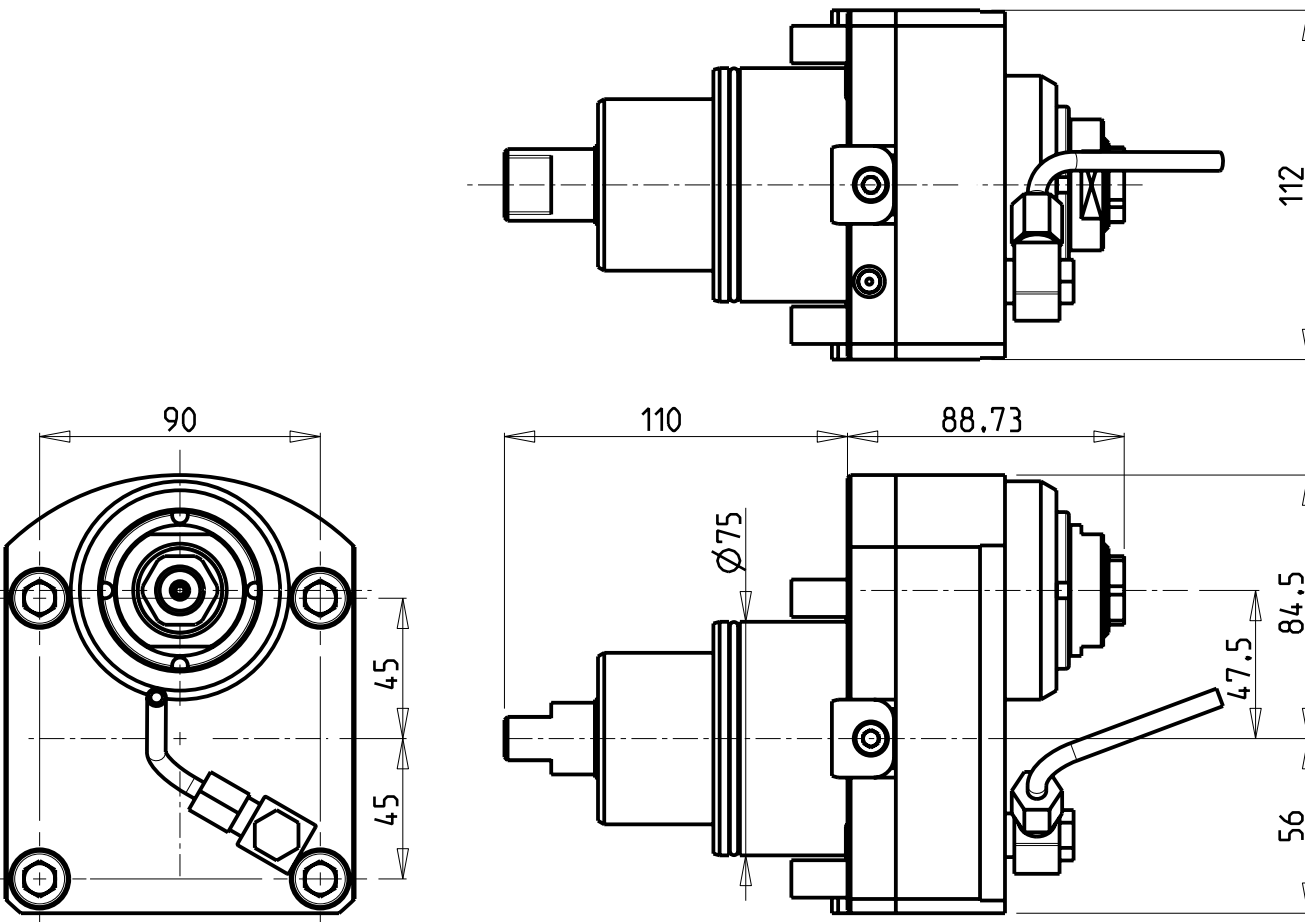

Cod. MT	Mandrino Spindle Spindel	I	RPM	Coppia Max Max Torque Max Drehmoment	Reversibile lato mandrino/contromandrino Reversible sub/main spindle side Umkehrbare Spindelseite/ Gegenspindelseite	Lubr. esterna Ext. coolant Aussenkuehlung	CHIAVI NON INCLUSE Keys not included Schluessel nicht einbegriffen
DW00430220	ERA20	1:2	12000	50Nm	X	X	CHUB36 CHUB22

DOOSAN BMT 75

MOD: PUMA 400 - PUMA 480M/LM/XLM - VT 750M/TM

MODULO MOTOR. RADIALE MOLTIPLICATO I=1:2 DISASSATO IN Z 47.5mm

Radial geared-up I=1:2 driven tool re-directed in Z by 47.5mm

Radial angetriebenes Werkzeug uebersetzt I=1:2 achsversetzt in Z um 47.5mm

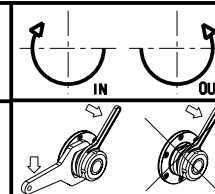

**M.T. srl**

Via Casino Albini 480  
Tel. 0541/956034-957884

Fax 0541/956341

47842 S. GIOVANNI IN M. (RN)  
e-mail: mtma@mtmarchetti.com  
http://www.mtmarchetti.com

PRODUZIONE MODULI ROTANTI



PAGINA DW 0033-4-30

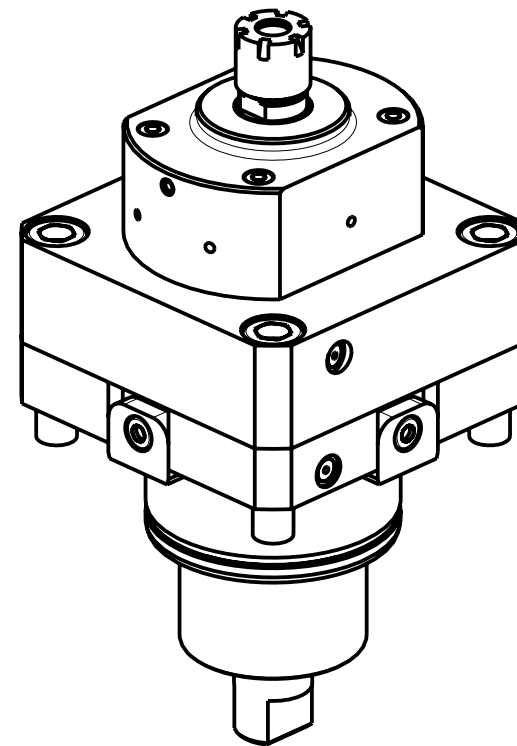
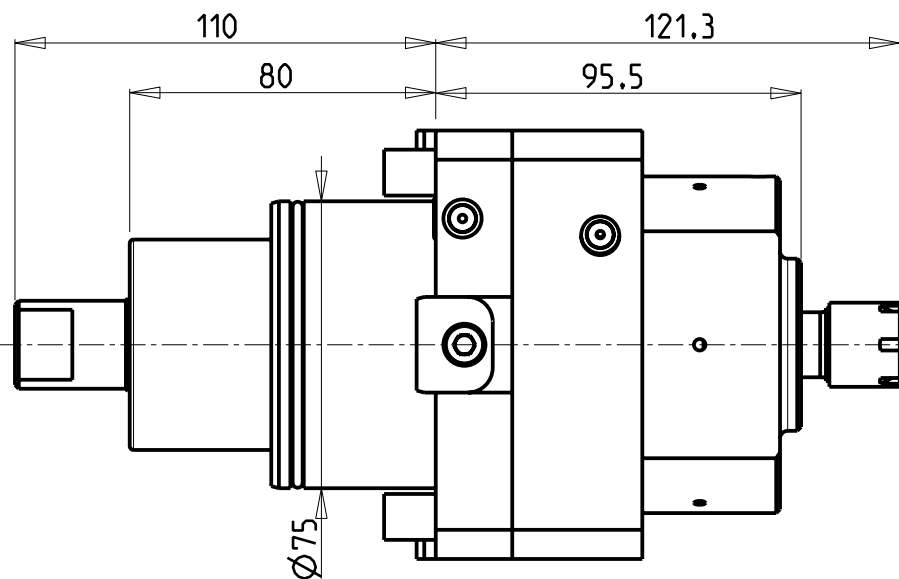
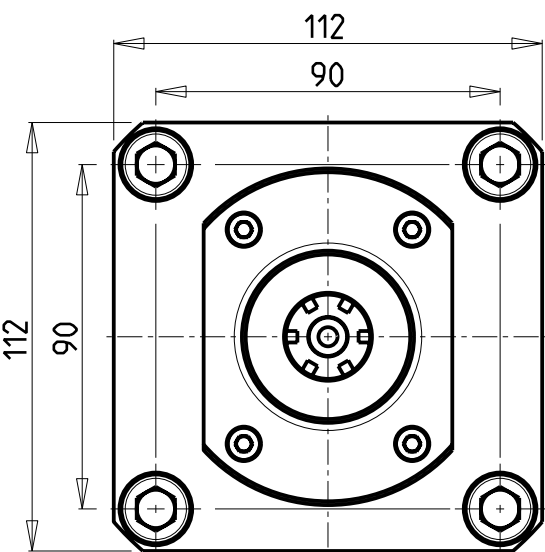

**ATTENZIONE - ATTENTION - ACHTUNG**

- PRIMA DI UTILIZZARE IL MOTORIZZATO CONSULTARE LE ISTRUZIONI ALLEGATE!
- BEFORE USING THE DRIVEN TOOL, PLEASE CHECK THE ENCLOSED INSTRUCTION SHEET!
- VOR DER BENUTZUNG DES ANGETRIEBENEN WERKZEUGES, DIE BEILIEGENDEN INSTRUKTIONEN DURCHLESEN!

**ATTENZIONE - ATTENTION - ACHTUNG**

- Per lo smontaggio degli utensili utilizzare sempre la chiave di contrasto come indicato nel manuale d'uso.
- For disassembly of the tools use always the contrast key as mentioned in the user instructions.
- Fuer das Abmontieren der Werkzeuge immer den Gegenschlüssel benutzen wie in der Bedienungsanleitung erwäehnt.

Cod. MT	Mandrino Spindle Spindel	I	RPM	Coppia Max Max Torque Max Drehmoment	Lubrificazione int. Coolant through Innenkuehlung	CHIAVI INCLUSE Keys included Schluessel einbegriffen	
DW00450116	ER16	1:4	12000	15Nm	P=30bar	CHMNER16	CHUB17

DOOSAN BMT 75

MOD: PUMA 400 - PUMA 480M/LM/XLM - VT 750M/TM

MODULO MOTORIZZATO RADIALE MOLTIPLICATO I=1:4

Radial geared-up I=1:4 driven tool

Radial angetriebenes Werkzeug uebersetzt I=1:4

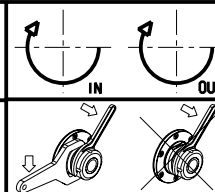

**M.T. srl**

Via Casino Albini 480  
Tel. 0541/956034-957884  
Fax 0541/956341

47842 S. GIOVANNI IN M. (RN)  
e-mail: mtma@mtmarchetti.com  
http://www.mtmarchetti.com

PRODUZIONE MODULI ROTANTI



PAGINA DW 0058-4-00

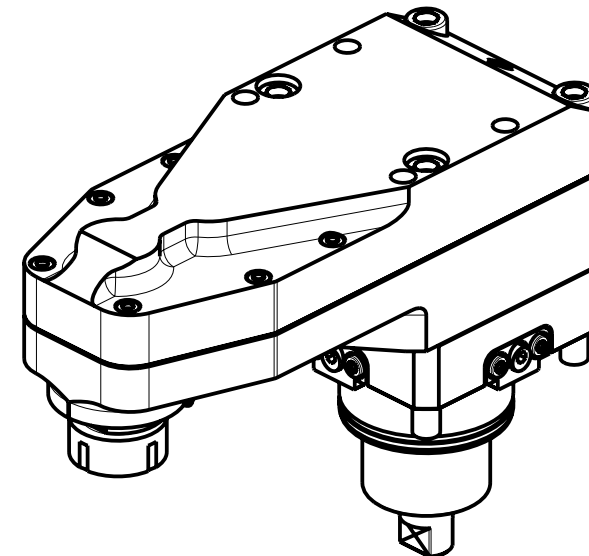
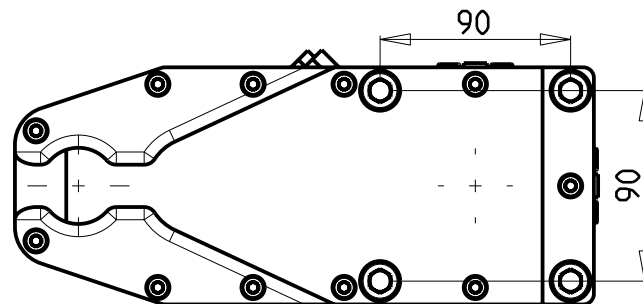
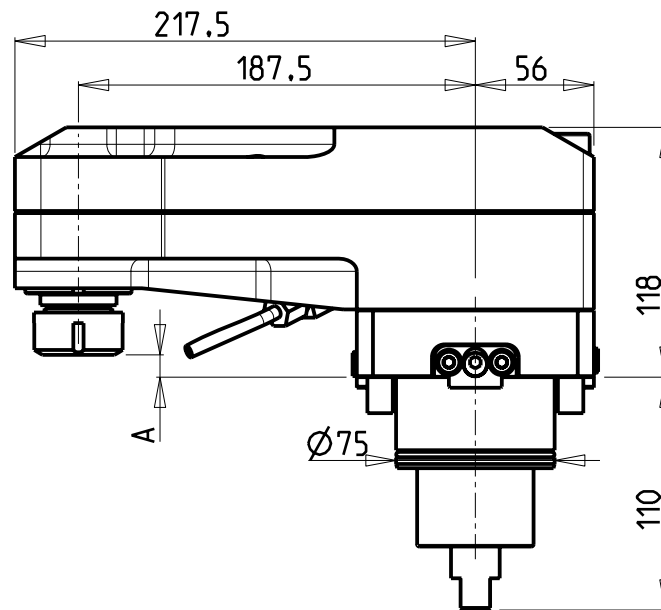
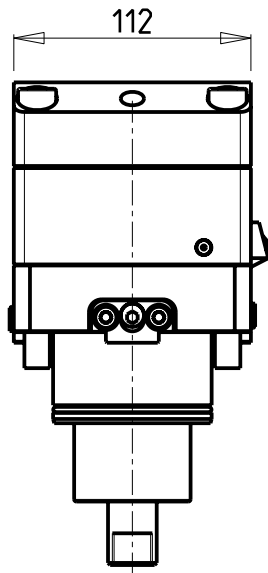

Cod. MT	Mandrino Spindle Spindel	I	RPM MAX	Coppia Max Max Torque Max Drehmoment	Lubrificazione est. Ext. coolant Ausseinkuehlung	A	CHIAVI NON INCLUSE Keys not included Schlüssel nicht einbegriffen	
							CHSTER25	CHUB36
0841225	ER25	1:2	8000	40Nm	X	8.84	CHSTER25	CHUB36
0841232	ER32	1:2	8000	40Nm	X	3.66	CHSTER32	CHUB36

## DOOSAN BMT 75

MOD: PUMA 400 - PUMA 480M/LM/XLM

MODULO MOTORIZZATO RADIALE ROVESCiato DISASSATO IN Z 187.5mm

Radial inverted driven tool re-directed in Z by 187.5 mm

Radial angetriebenes Werkzeug ungekehrt achsversetzt in Z um 187.5 mm

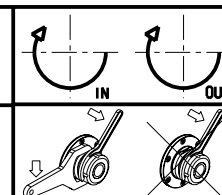

### M.T. srl

Via Casino Albini 480  
Tel. 0541/956034-957884  
Fax 0541/956341

47842 S. GIOVANNI IN M. (RN)  
e-mail: mtma@mtmarchetti.com  
http://www.mtmarchetti.com

PRODUZIONE MODULI ROTANTI



PAGINA DW 0120-4-10

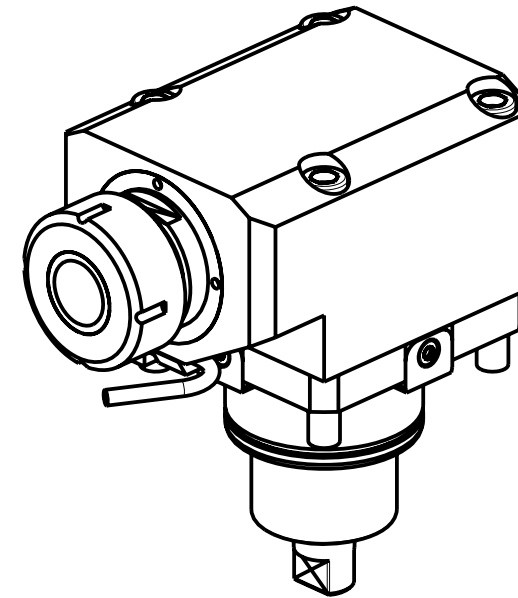
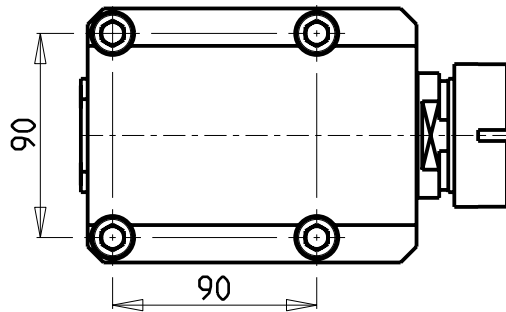
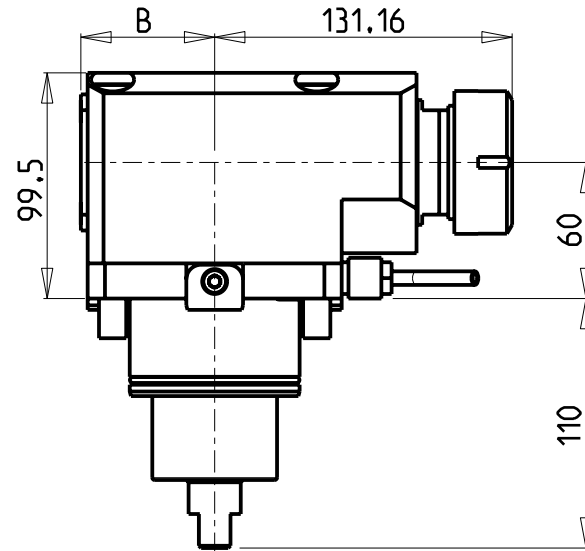
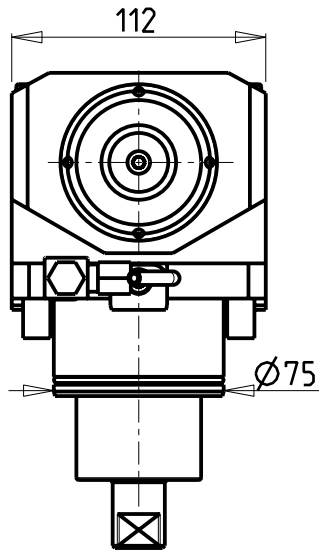

Cod. MT	Cod. EPPINGER	Mandrino Spindle Spindel	I	RPM	Coppia Max Max Torque Max Drehmoment	Lubrificazione int. Coolant through Innenkuehlung	Lubrificazione est. Ext. coolant Aussenkuehlung	B	CHIAVI NON INCLUSE Keys not included Schlüssel nicht einbegriffen	
									CHSTER40	CHUB46
0330840	7.070.935	ER40	1:1	6000	100Nm		X	59	CHSTER40	CHUB46
0331040	-	ER40	1:1	6000	100Nm	P=70bar	X	85	CHSTER40	CHUB46

## DOOSAN BMT 75

MOD: PUMA 400 - PUMA 480M/LM/XLM

MODULO MOTORIZZATO ASSIALE H=60mm

Axial driven tool H=60mm

Axial angetriebenes Werkzeug H=60mm

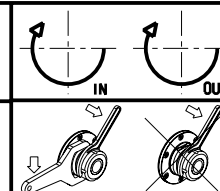

### M.T. srl

Via Casino Albini 480  
Tel. 0541/956034-957884

Fax 0541/956341

47842 S. GIOVANNI IN M. (RN)

e-mail: mtma@mtmarchetti.com

http://www.mtmarchetti.com

PRODUZIONE MODULI ROTANTI



PAGINA DW 0150-4-10



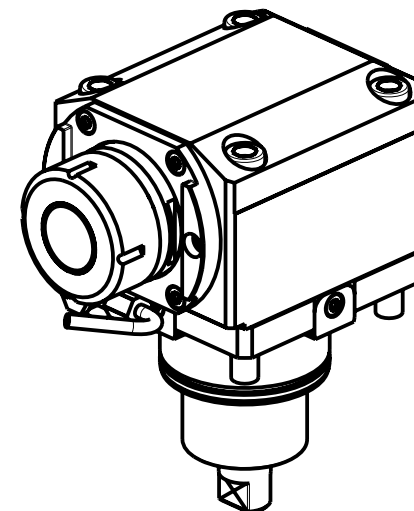
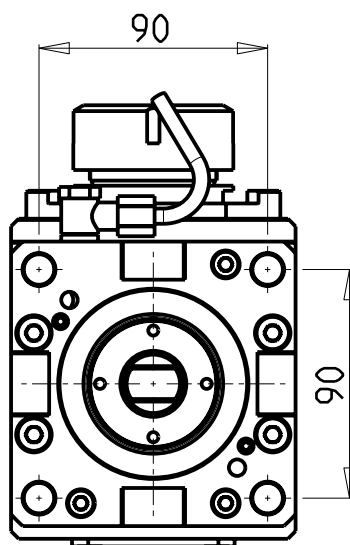
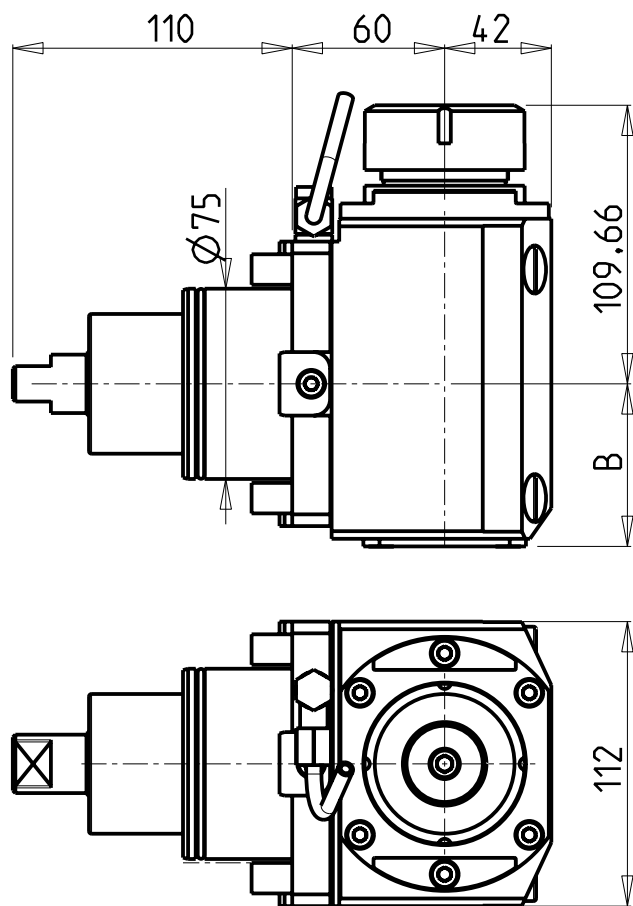

### CUSCINETTI MAGGIORATI PER LAVORAZIONI PESANTI

Reinforced bearings for  
heavy machining

Vergroesserte Lager fuer  
schwerere Bearbeitungen

Cod. MT	Mandrino Spindle Spindel	I	RPM	Coppia Max Max Torque Max Drehmoment	Lubrificazione int. Coolant through Innenkuehlung	Lubrificazione est. Ext. coolant Aussenkuehlung	B	CHIAVI NON INCLUSE Keys not included Schlüssel nicht einbegriffen	
								CHSTER40	OKU0430007
DW00680140	ER40	1:1	6000	100Nm		X	64	CHSTER40	OKU0430007
DW00680240	ER40	1:1	6000	100Nm	P=70bar	X	77.5	CHSTER40	OKU0430007

- Chiave inclusa
- Key included
- Schlüssel inbegriffen

DOOSAN BMT 75

MOD: PUMA 400 - PUMA 480M/LM/XLM

MODULO MOTORIZZATO ASSIALE MAGGIORATO H=60mm

Axial reinforced driven tool H=60mm

Axial angetriebenes Werkzeug vergroessert H=60mm

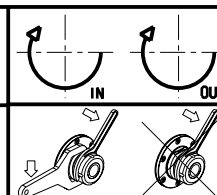

**M.T. srl**

Via Casino Albini 480  
Tel. 0541/956034-957884  
Fax 0541/956341

47842 S. GIOVANNI IN M. (RN)  
e-mail: mtma@mtmarchetti.com  
http://www.mtmarchetti.com

PRODUZIONE MODULI ROTANTI



PAGINA DW 0170-4-10

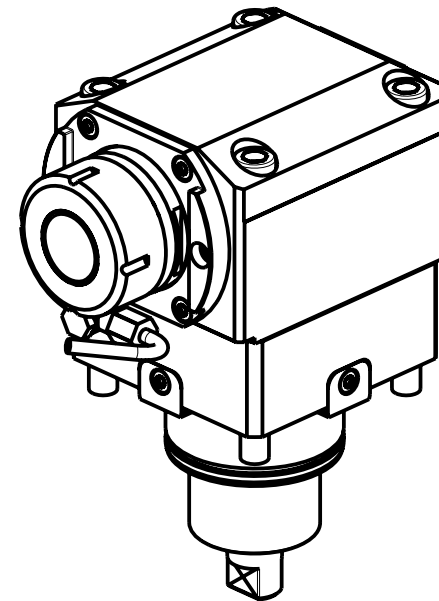
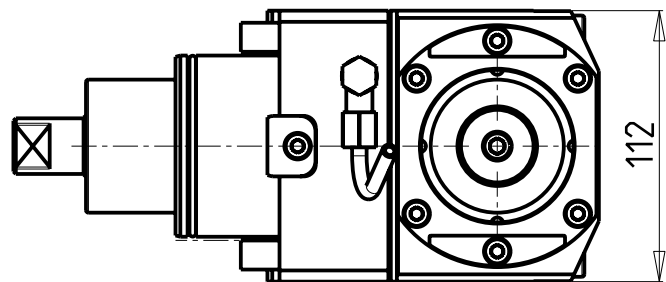
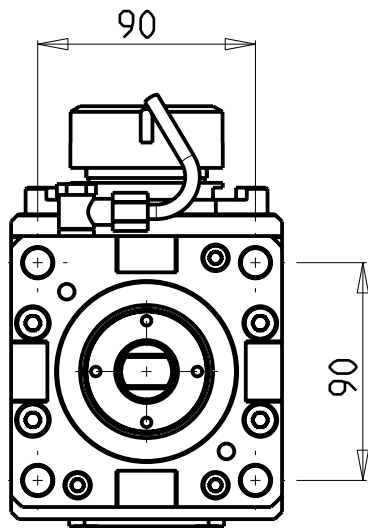
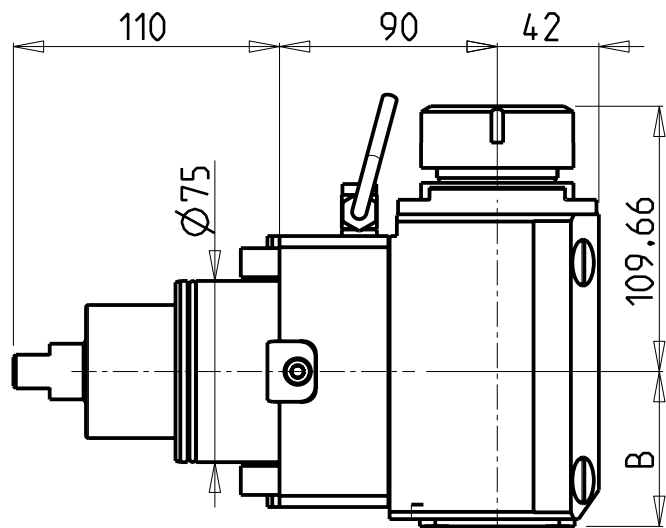

## CUSCINETTI MAGGIORATI PER LAVORAZIONI PESANTI

Reinforced bearings for  
heavy machining

Vergroesserte Lager fuer  
schwerere Bearbeitungen

Cod. MT	Mandrino Spindle Spindel	I	RPM	Coppia Max Max Torque Max Drehmoment	Lubrificazione int. Coolant through Innenkuehlung	Lubrificazione est. Ext. coolant Aussenkuehlung	B	CHIAVI NON INCLUSE Keys not included Schlüssel nicht einbegriffen	
DW00650140	ER40	1:1	6000	100Nm		X	64	CHSTER40	OKU0430007 •
DW00650240	ER40	1:1	6000	100Nm	P=70bar	X	77.5	CHSTER40	OKU0430007 •

• Chiave inclusa
• Key included
• Schlüssel inbegriffen

DOOSAN BMT 75

MOD: PUMA 400 - PUMA 480M/LM/XLM

MODULO MOTORIZZATO ASSIALE MAGGIORATO H=90mm

Axial reinforced driven tool H=90mm

Axial angetriebenes Werkzeug vergroessert H=90mm

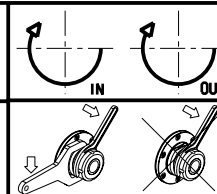

**M.T. srl**

Via Casino Albini 480  
Tel. 0541/956034-957884  
Fax 0541/956341

47842 S. GIOVANNI IN M. (RN)  
e-mail: mtma@mtmarchetti.com  
http://www.mtmarchetti.com

PRODUZIONE MODULI ROTANTI



PAGINA DW 0170-4-20

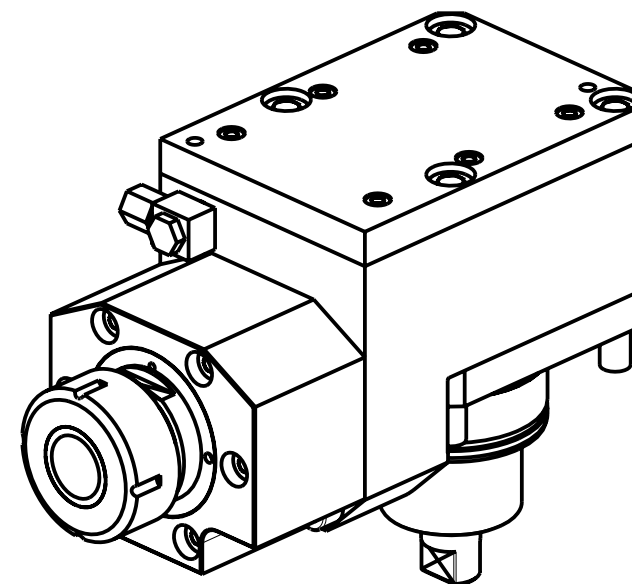
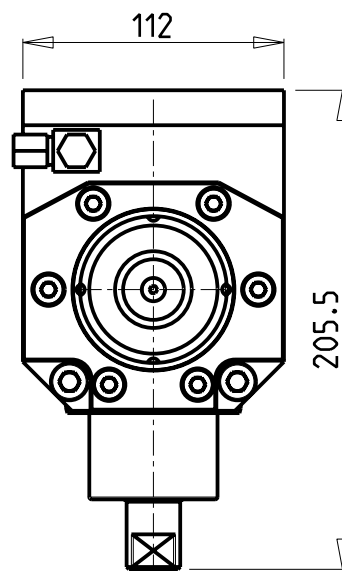
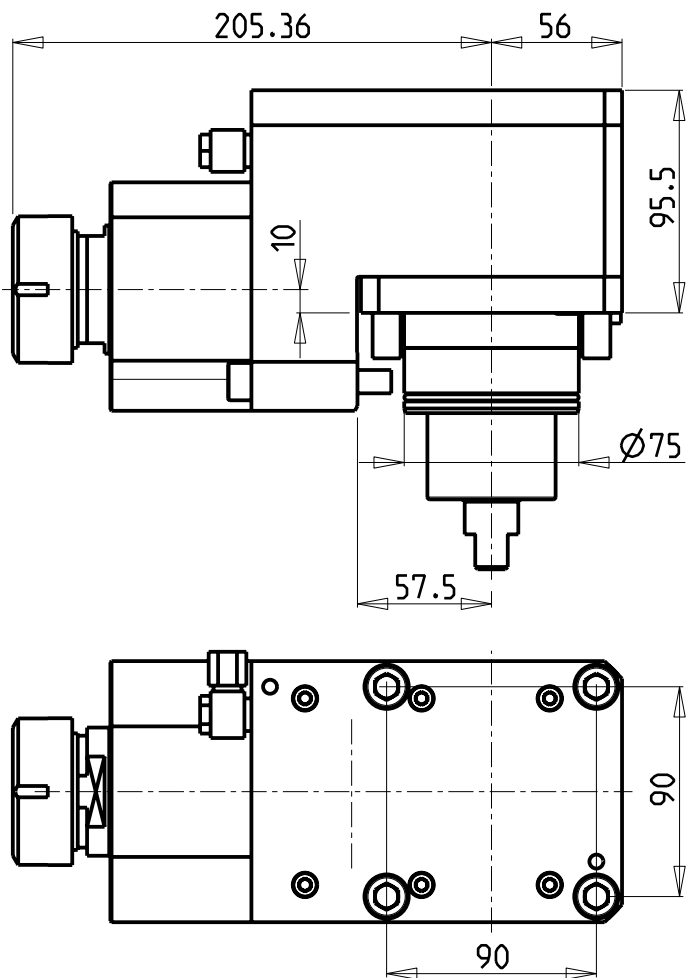

Cod. MT	Mandrino Spindle Spindel	i	RPM max	Coppia Max Max Torque Max Drehmoment	Lubrificazione est. Ext. coolant Aussenkuehlung	CHIAVI NON INCLUSE Keys not included Schlüssel nicht einbegriffen	
						CHSTER40	CHUB46
0350640	ER40	1:1	6000	100Nm	X	CHSTER40	CHUB46

## DOOSAN BMT 75

MOD: PUMA 400 - PUMA 480M/LM/XLM

MODULO MOTORIZZATO ASSIALE H=10mm

Axial driven tool H=10mm

Axial angetriebenes Werkzeug H=10mm

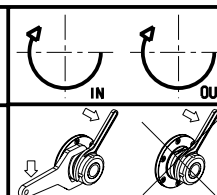

## M.T. srl

Via Casino Albini 480  
Tel. 0541/956034-957884  
Fax 0541/956341

47842 S. GIOVANNI IN M. (RN)  
e-mail: mtma@mtmarchetti.com  
http://www.mtmarchetti.com

PRODUZIONE MODULI ROTANTI



PAGINA DW 0180-4-10

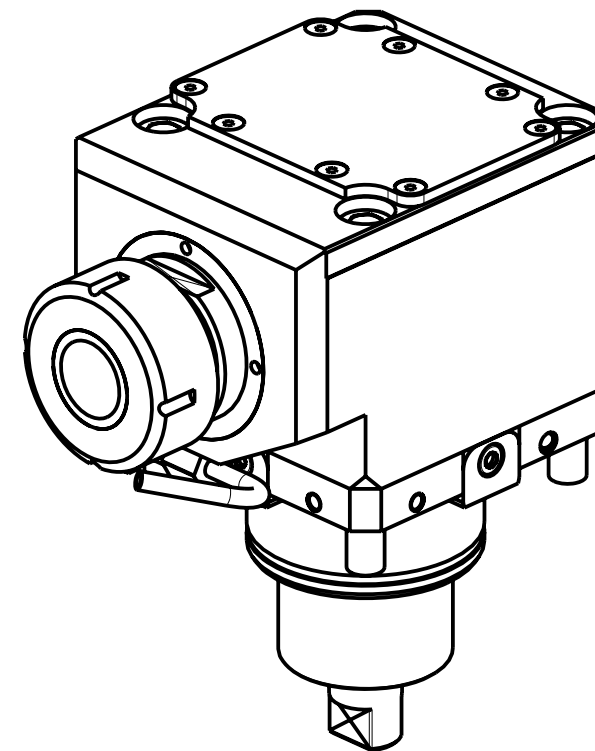
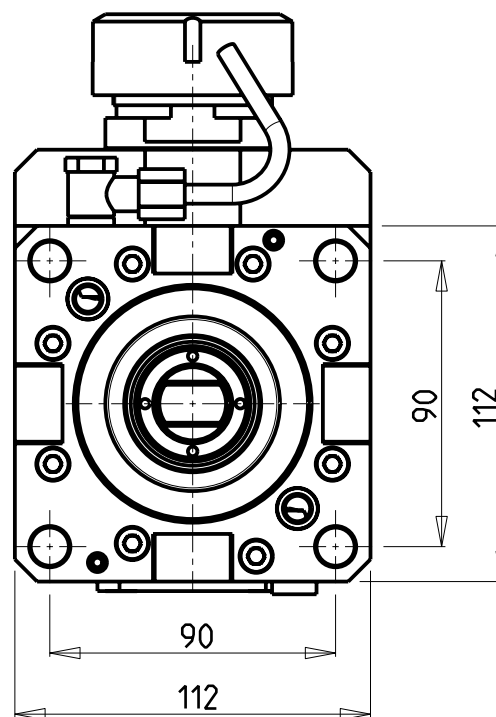
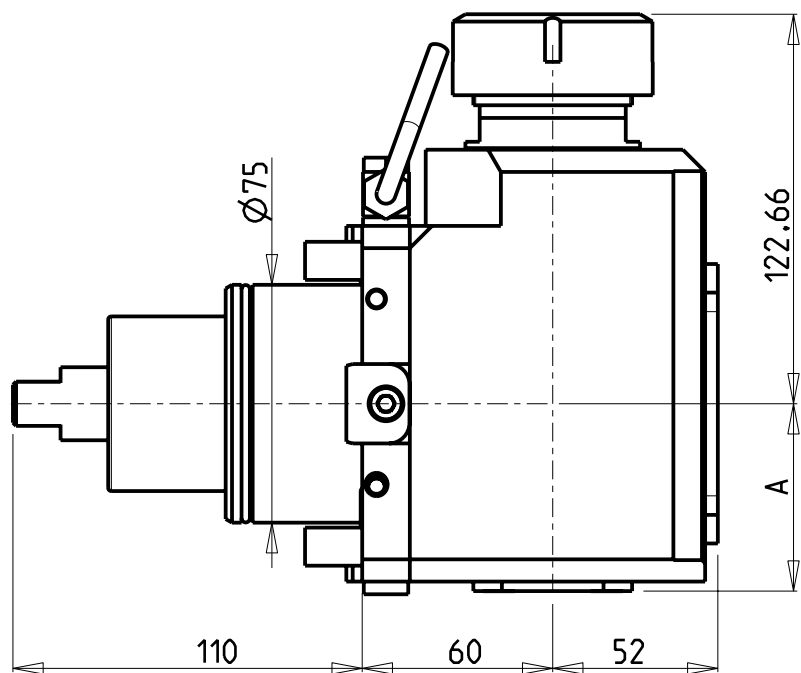

Cod. MT	Mandrino Spindle Spindel	I	RPM	Coppia Max Max Torque Max Drehmoment	Reversibile lato mandrino/contromandrino Reversible sub/main spindle side Umkehrbare Spindel-seite/ Gegenspindel-seite	Lubrificazione int. Coolant through Innenkühlung	Lubrificazione est. Ext. coolant Aussenkühlung	A	CHIAVI NON INCLUSE Keys not included Schlüssel nicht einbegriffen	
DW00470140	ER40	2:1	3000	140Nm	X		X	59	CHUB46	CHSTER40
DW00470240	ER40	2:1	3000	140Nm	X	P=70bar	X	72.5	CHUB46	CHSTER40

DOOSAN BMT 75  
 MOD: PUMA 400 - PUMA 480M/LM/XLM  
 MODULO MOTORIZZATO ASSIALE RIDOTTO I=2:1  
 Axial geared-down I=2:1 driven tool  
 Axial angetriebenes Werkzeug untersetzt I=2:1

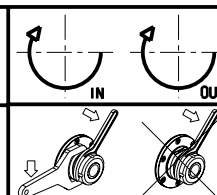

**M.T. srl**  
 Via Casino Albini 480  
 Tel. 0541/956034-957884  
 Fax 0541/956341  
 47842 S. GIOVANNI IN M. (RN)  
 e-mail: mtma@mtmarchetti.com  
 http://www.mtmarchetti.com

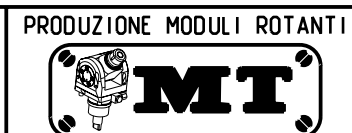

PAGINA DW 0190-4-10

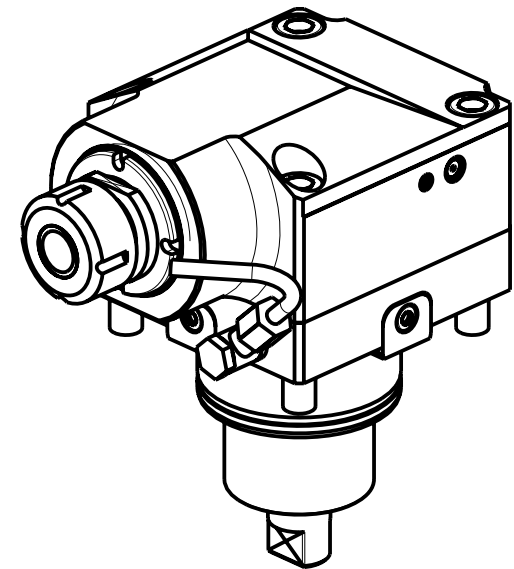
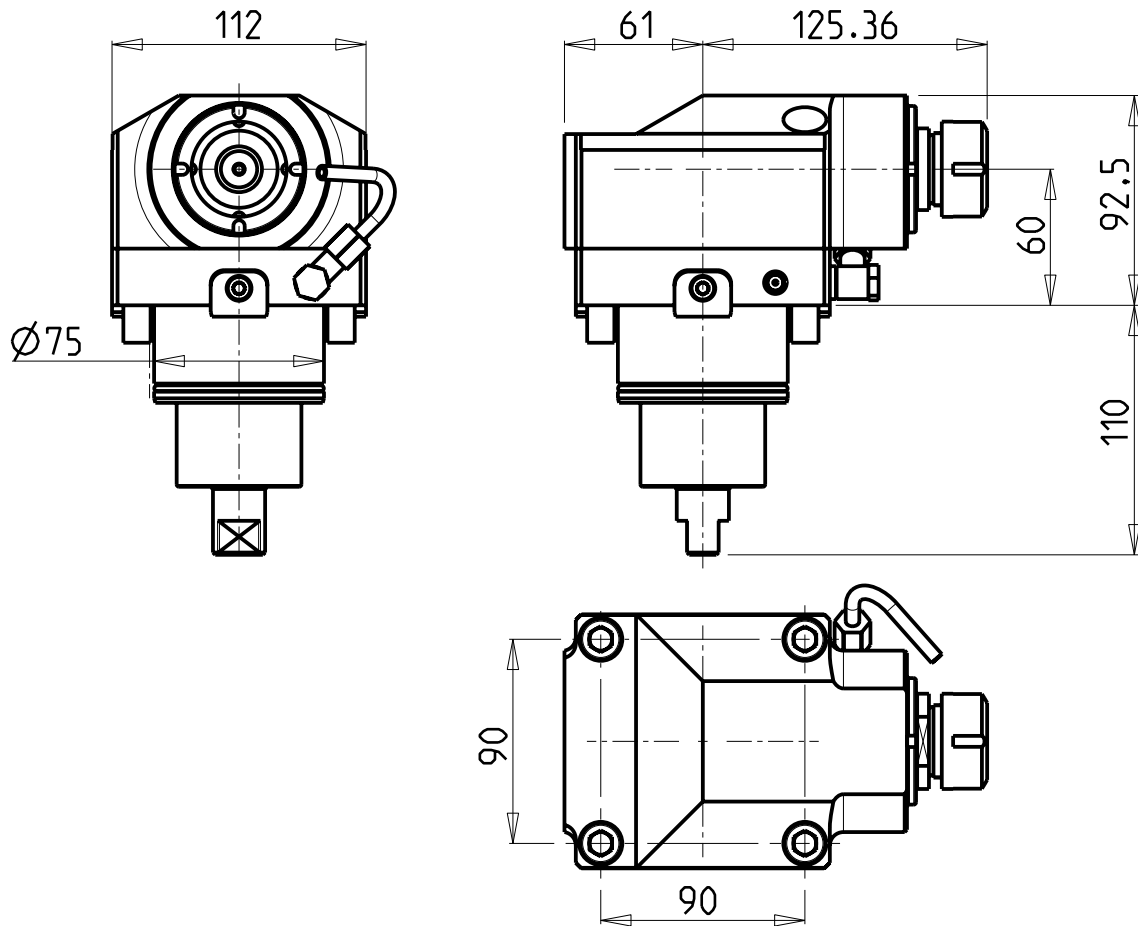

Cod. MT	Mandrino Spindel Spindel	i	RPM MAX	Coppia Max Max Torque Max Drehmoment	Lubrificazione int. Coolant through Innenkuehlung	Lubrificazione est. Ext. coolant Aussenkuehlung	CHIAVI NON INCLUSE Keys not included Schlüssel nicht einbegriffen	
							CHSTER25	CHUB36
DW00570125	ER25	1:3	12000	60Nm		X	CHSTER25	CHUB36
DW00570225	ER25	1:3	12000	60Nm	P=70bar	X	CHSTER25	CHUB36

DOOSAN BMT 75

MOD: PUMA 400 - PUMA 480M/LM/XLM

MODULO MOTORIZZATO ASSIALE MOLTIPLICATO I=1:3

Axial geared-up I=1:3 driven tool

Axial angetriebenes Werkzeug uebersetzt I=1:3

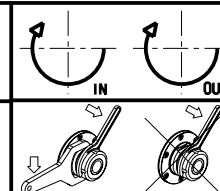

**M.T. srl**

Via Casino Albini 480  
Tel. 0541/956034-957884

Fax 0541/956341

47842 S. GIOVANNI IN M. (RN)

e-mail: mtma@mtmarchetti.com

http://www.mtmarchetti.com

PRODUZIONE MODULI ROTANTI



PAGINA DW 0205-4-10

**ATTENZIONE - ATTENTION - ACHTUNG**

- Per lo smontaggio degli utensili utilizzare sempre la chiave di contrasto come indicato nel manuale d'uso.
- For disassembly of the tools use always the contrast key as mentioned in the user instructions.
- Fuer das Abmontieren der Werkzeuge immer den Gegenschlüssel benutzen wie in der Bedienungsanleitung erwäehnt.

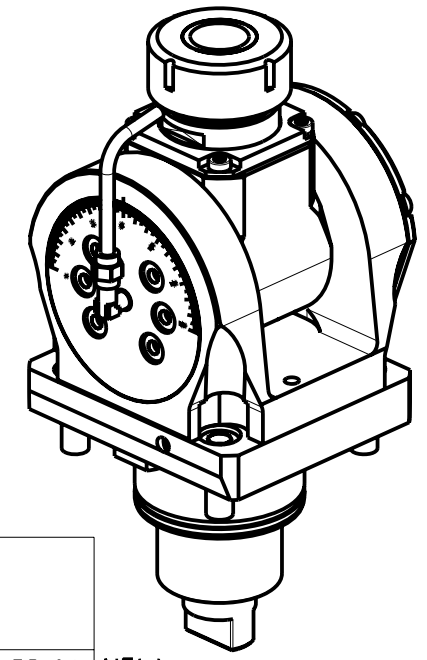
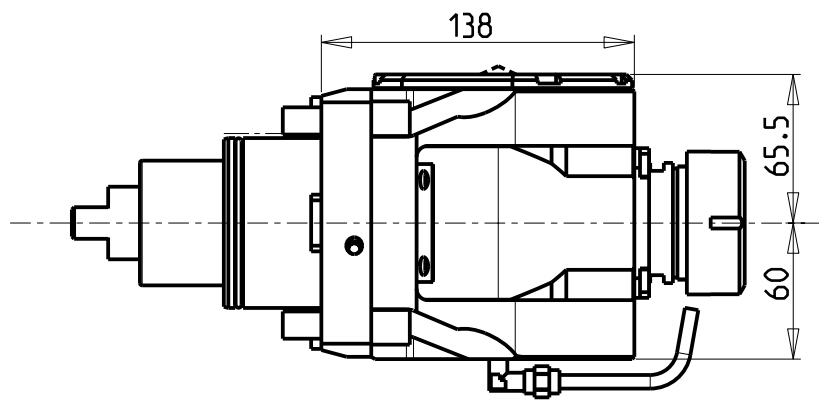
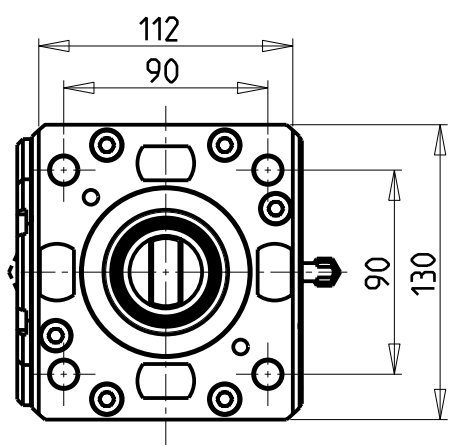
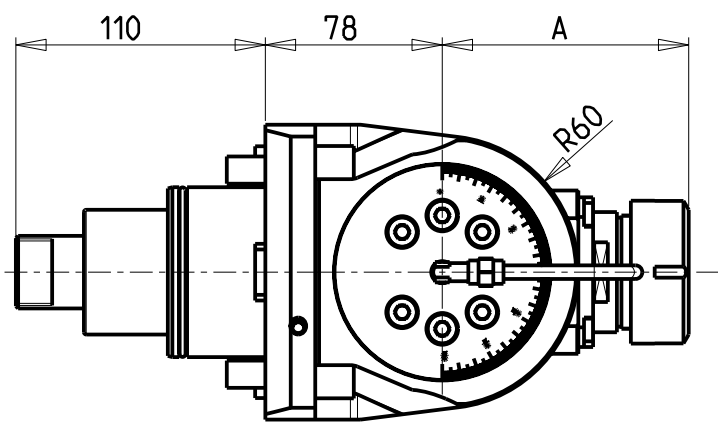

Cod. MT	Mandrino Spindel Spindel	I	RPM	Coppia Max Max Torque Max Drehmoment	Lubrificazione int. Coolant through Innenkuehlung	Lubrificazione est. Ext. coolant Aussenkuehlung	A	CHIAVI INCLUSE Keys included Schluessel inbegriffen					
DW 00820332	ERA32	1:1	6000	50Nm		X	81	CHUB30	CHUB46	CHTAER32ZC	CHESL10	CHESLO6	NEW
DW 00820432	ERA32	1:1	6000	50Nm	P=70bar	X	81	CHUB30	CHUB46	CHTAER32ZC	CHESL10	CHESLO6	NEW
DW 00820140	ER40	1:1	6000	50Nm		X	108.66	-	CHUB46	CHSTER40	CHESL10	CHESLO6	NEW
DW 00820240	ER40	1:1	6000	50Nm	P=70bar	X	108.66	-	CHUB46	CHSTER40	CHESL10	CHESLO6	NEW

**DOOSAN BMT 75**  
 MOD: PUMA 400 - PUMA 480M/LM/XLM - VT 750M/TM

MODULO MOTORIZZATO ORIENTABILE +/-90°  
 +/-90° adjustable angle driven tool  
 Angetriebenes Werkzeug schwenkbar +/-90°

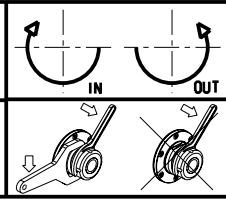

**M.T. srl**  
 Via Casino Albini 480  
 Tel. 0541/956034-957884  
 Fax 0541/956341  
 47842 S. GIOVANNI IN M. (RN)  
 e-mail: mtma@mtmarchetti.com  
 http://www.mtmarchetti.com

PRODUZIONE MODULI ROTANTI  

PAGINA DW 0339-4-00

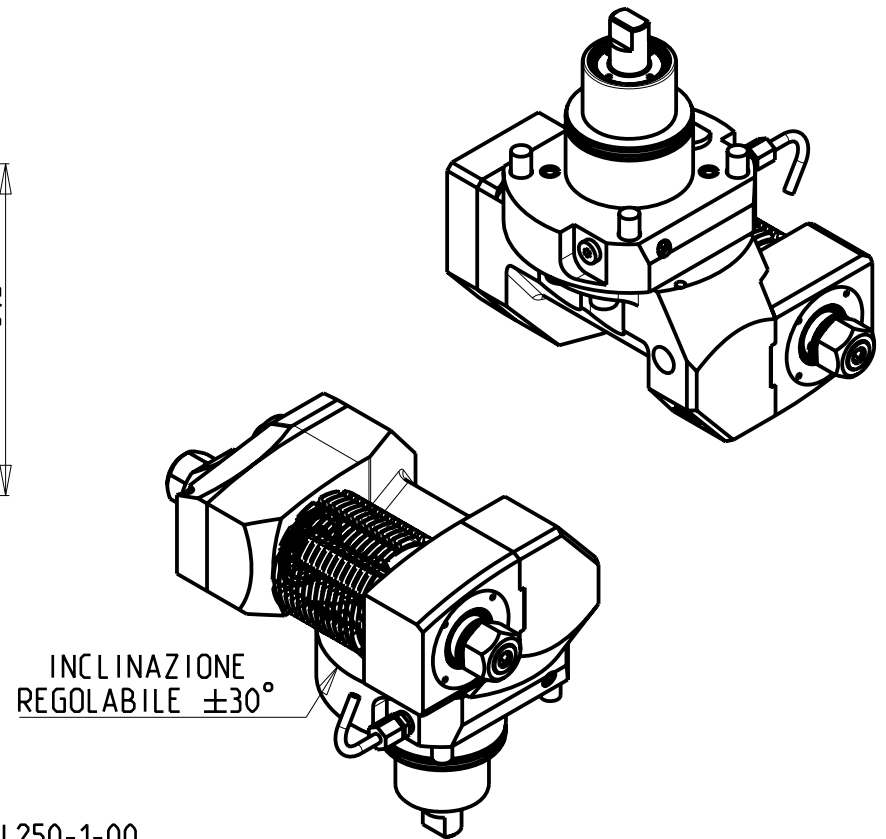
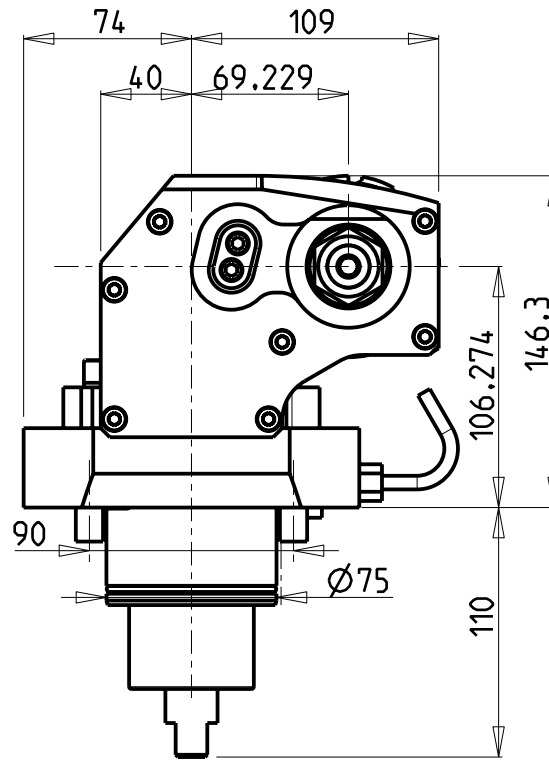
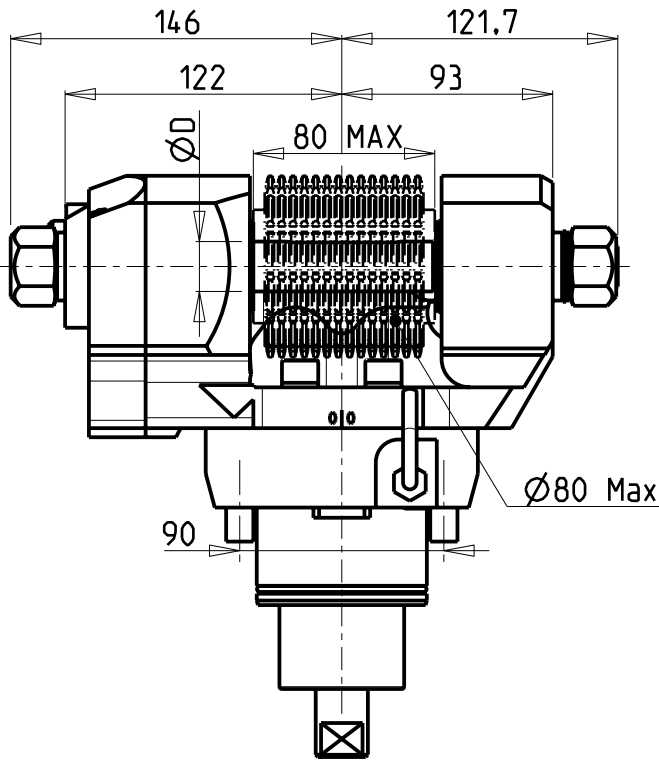

**DOTAZIONI - SUPPLIED WITH - AUSSTATTUNG**

- mm / inch
- N°1 ALBERO + DISTANZIALI
  - N°1 SHAFT + SPACER
  - N°1 DORN + ABSTANDSSTUECK

PER ALBERI E DISTANZIALI VEDI PAG. TBL250-1-00  
 FOR SHAFT END SPACER SEE PAGE TBL250-1-00  
 FUER DORN UND ABSTANDSSTUECK SEITE TBL250-1-00

Cod. MT	I	RPM	Coppia Max Max Torque Max Drehmoment	Reversibile lato mandrino/contromandrino Reversible sub/main spindle side Umkehrbare Spindel-seite/ Gegenspindel-seite	Lubrificazione est. Ext. coolant Aussenkuehlung	D (mm)	D (Inch)	CHIAVI INCLUSE Keys included Schlüssel inbegriffen		
								CHUB30	CHE8L08	CHUB24 (Ø16 / Ø3/4")
DW00251100	1:1	6000	90Nm	X	X	16-22-27-32	3/4"-1"-1 1/4"	CHUB30	CHE8L08	CHUB24 (Ø16 / Ø3/4")
DW00252100	2:1	3000	110Nm	X	X	16-22-27-32	3/4"-1"-1 1/4"	CHUB30	CHE8L08	CHUB24 (Ø16 / Ø3/4")

**DOOSAN BMT 75**

MOD: PUMA 400 - PUMA 480M/LM/XLM - VT 750M/TM

MODULO MOTORIZZATO PORTACREATORE MAGGIORATO

Reinforced driven gear hobber

Angetriebenes Zahnradwaelzfraes-Werkzeug vergroessert

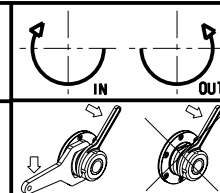

**M.T. srl**

Via Casino Albini 480  
 Tel. 0541/956034-957884

Fax 0541/956341

47842 S. GIOVANNI IN M. (RN)

e-mail: mtma@mtmarchetti.com

http://www.mtmarchetti.com

PRODUZIONE MODULI ROTANTI



PAGINA DW0340-4-60

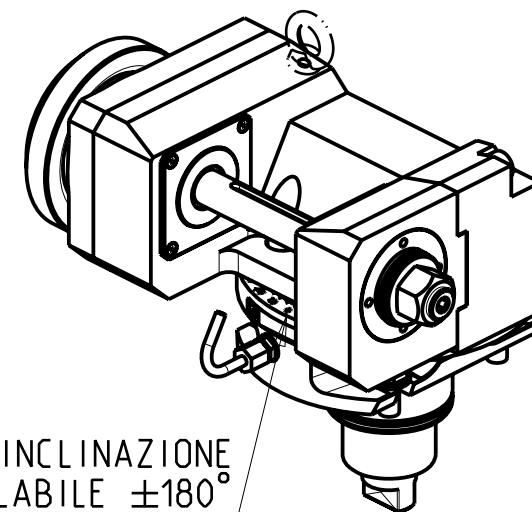
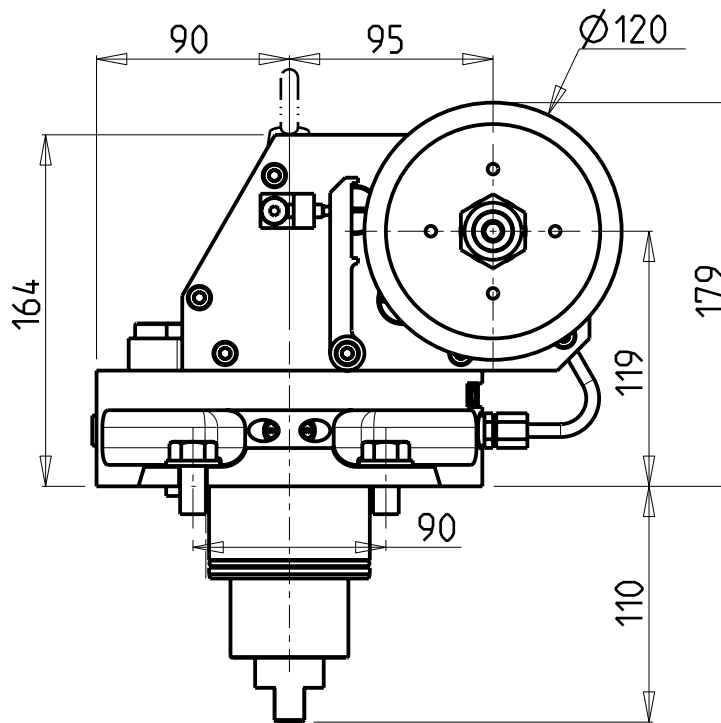
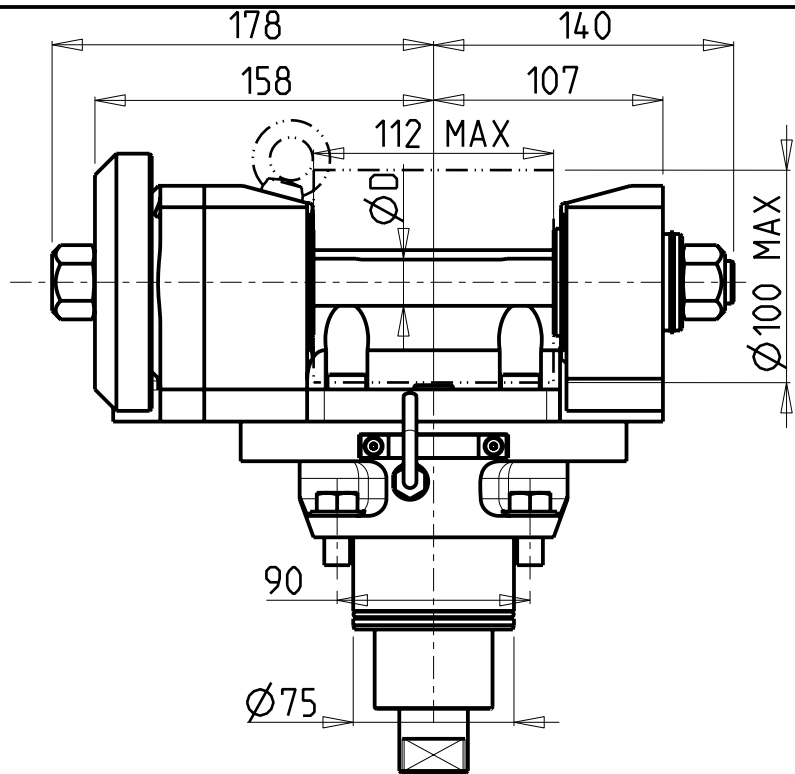

INCLINAZIONE  
REGOLABILE ±180°

**DOTAZIONI - SUPPLIED WITH - AUSSTATTUNG**

mm / inch

- N°1 ALBERO + DISTANZIALI
- N°1 SHAFT + SPACER
- N°1 DORN + ABSTANDSSTUECK

PER ALBERI E DISTANZIALI VEDI PAG. TBL250-1-00  
FOR SHAFT END SPACER SEE PAGE TBL250-1-00  
FUER DORN UND ABSTANDSSTUECK SEITE TBL250-1-00

Cod. MT	I	RPM MAX	Coppia Max Max Torque Max Drehmoment	Lubrificazione est. Ext. coolant Aussenkuehlung	D (mm)	CHIAVI INCLUDE Keys included Schlüssel inbegriffen				
						CHUB30	CHESL08	CHESL10	CHUB19	
DW0081100	1:1	6000	110Nm	X	22-27-32	CHUB30	CHESL08	CHESL10	CHUB19	NEW
DW00812100	2:1	3000	130Nm	X	22-27-32	CHUB30	CHESL08	CHESL10	CHUB19	NEW

DOOSAN BMT 75

MOD: PUMA 400 - PUMA 480M/LM/XLM - VT 750M/TM

MODULO MOTORIZZATO PORTACREATORE (TAGLIA GRANDE)

Driven gear hobber (big size)

Angetriebenes Zahnradwaelzfraes-Werkzeug (grosse version)

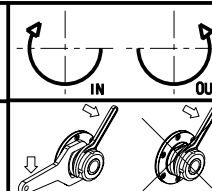

**M.T. srl**

Via Casino Albini 480  
Tel. 0541/956034-957884  
Fax 0541/956341

47842 S. GIOVANNI IN M. (RN)  
e-mail: mtma@mtmarchetti.com  
http://www.mtmarchetti.com

PRODUZIONE MODULI ROTANTI



PAGINA DW0340-4-80



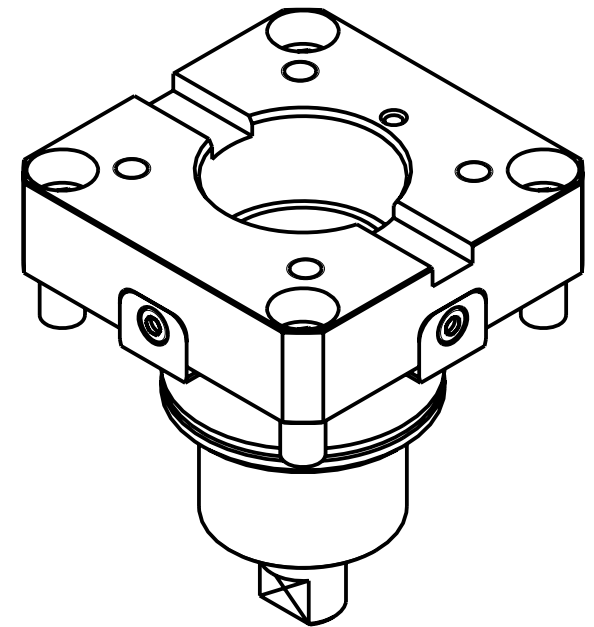
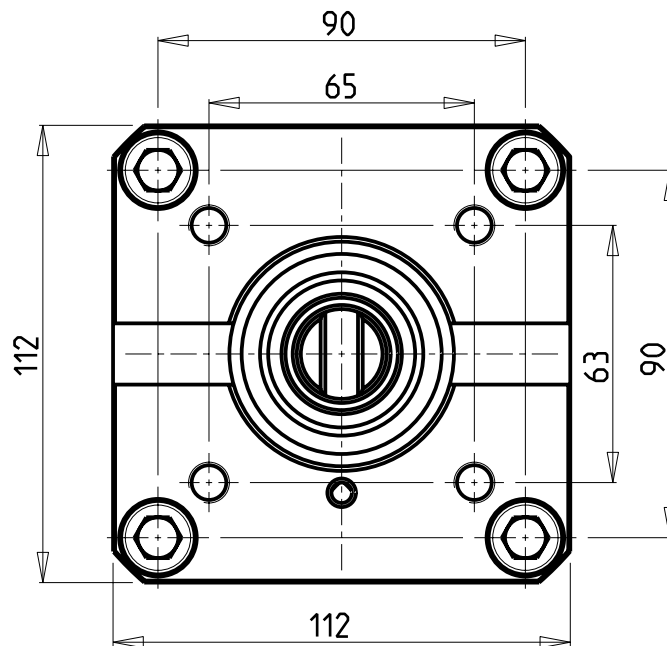
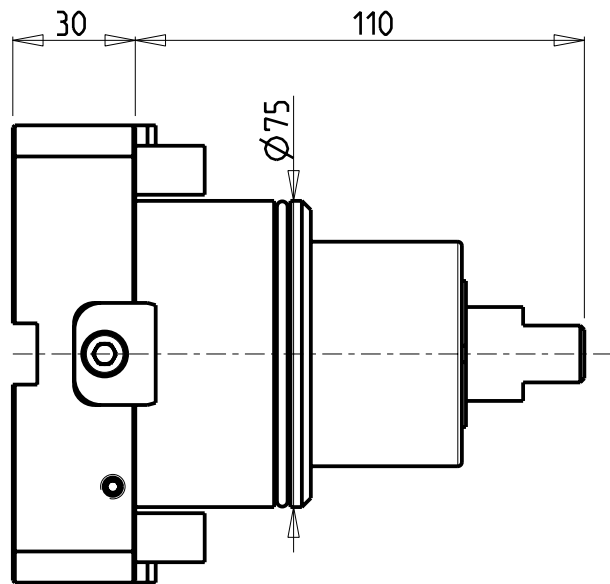

Cod. MT

0300075

DOOSAN BMT 75

MOD: PUMA 400 - PUMA 480M/LM/XLM - VT 750M/TM

INTERFACCIA PER MODULI BIGLIA

Biglia tooling adapter cartridge

Adapter-Patrone fuer Biglia Werkzeuge

**M.T. srl**

Via Casino Albini 480  
 Tel. 0541/956034-957884  
 Fax 0541/956341  
 47842 S. GIOVANNI IN M. (RN)  
 e-mail: mtma@mtmarchetti.com  
 http://www.mtmarchetti.com

PRODUZIONE MODULI ROTANTI



PAGINA DW0380-4-00

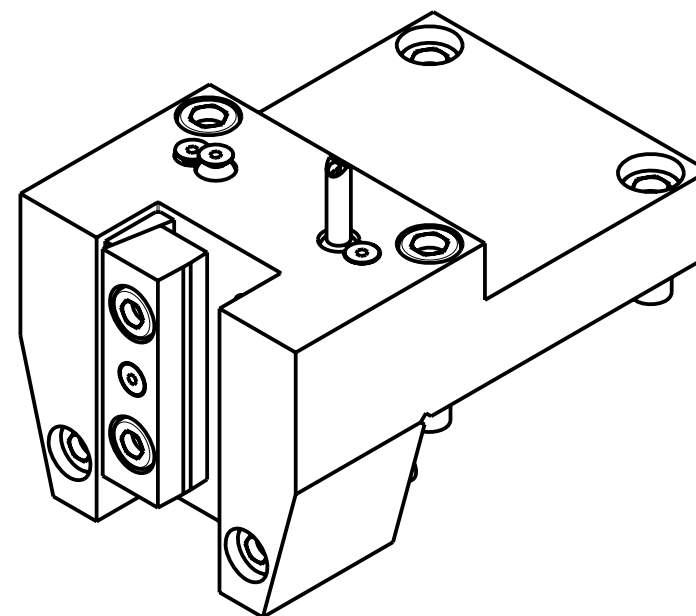
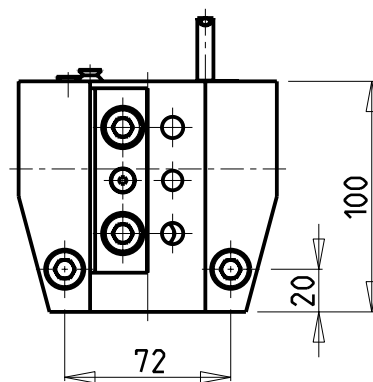
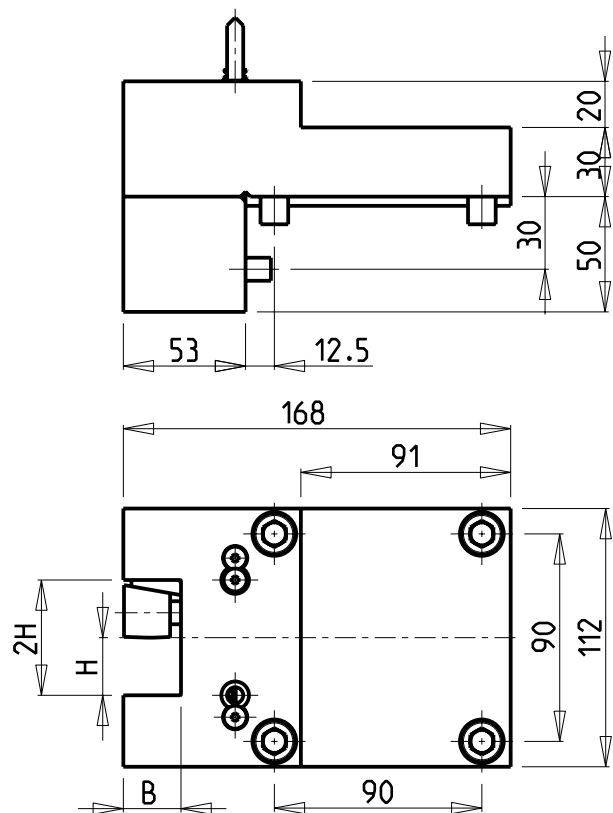

Cod. MT	N°Utensili N°Tools N°Werkzeuge	Misure Dimensions Masse	B	H
0902500	1	mm	25	25
0902540	1	Inch	1"	1"
0903200	1	mm	32	32
0903175	1	Inch	1-1/4"	1-1/4"

DOOSAN BMT 75

MOD: PUMA 400 - PUMA 480M/LM/XLM - VT 750M/TM

PORTAUTENSILE RADIALE SINGOLO

Radial single static tool

Radial Single-Werkzeughalter

**M.T. srl**

Via Casino Albini 480  
Tel. 0541/956034-957884  
Fax 0541/956341  
47842 S. GIOVANNI IN M. (RN)  
e-mail: mtma@mtmarchetti.com  
http://www.mtmarchetti.com

PRODUZIONE MODULI ROTANTI



PAGINA DW0423-4-00

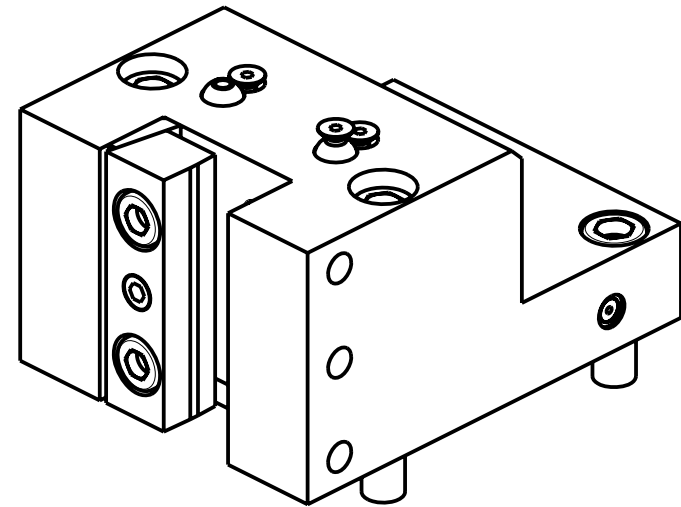
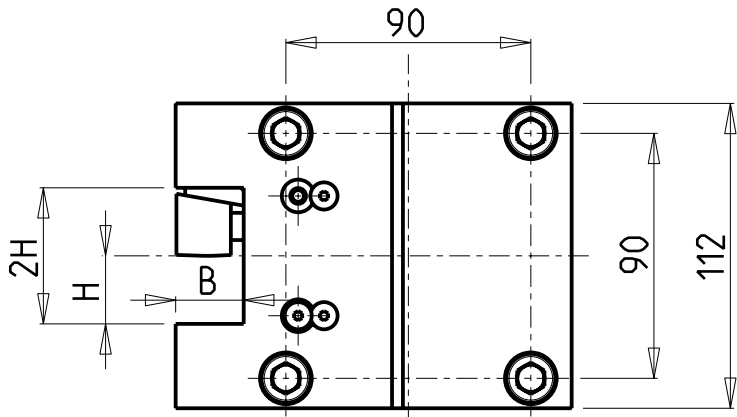
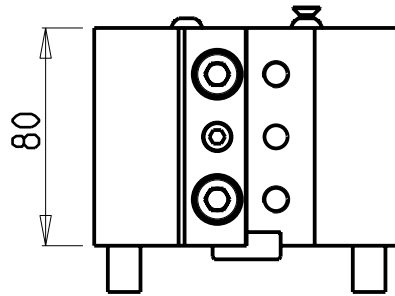
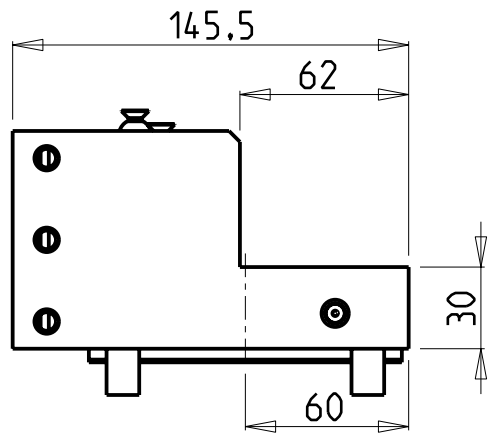

Cod. MT	N°Utensili N° Tools N° Werkzeuge	Reversibile lato mandrino/contromandrino Reversible sub/main spindle side Umkehrbare Spindelseite/ Gegenspindelseite	Misure Dimensions Masse	B	H	
DW 00752500	1	X	mm	25	25	NEW

DOOSAN BMT 75

MOD: PUMA 400 - PUMA 480M/LM/XLM - VT 750M/TM

PORTAUTENSILE RADIALE SINGOLO

Radial single static tool

Radial Single-Werkzeughalter

**M.T. srl**

Via Casino Albini 480  
Tel. 0541/956034-957884  
Fax 0541/956341  
47842 S. GIOVANNI IN M. (RN)  
e-mail: mtma@mtmarchetti.com  
http://www.mtmarchetti.com

PRODUZIONE MODULI ROTANTI



PAGINA DW 0423-4-01

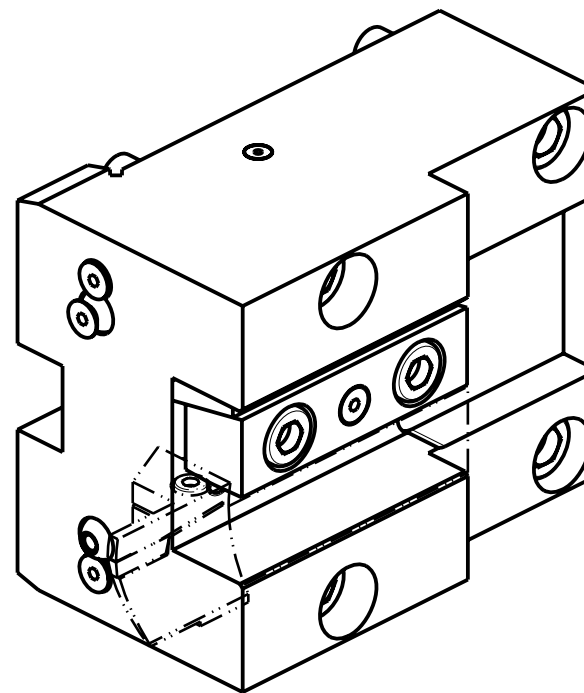
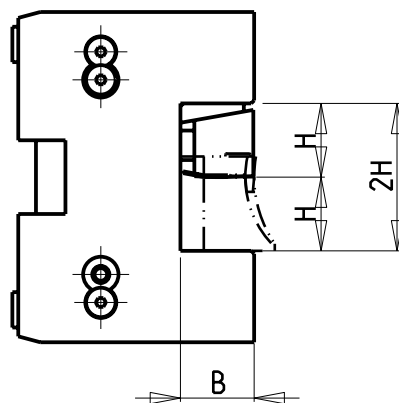
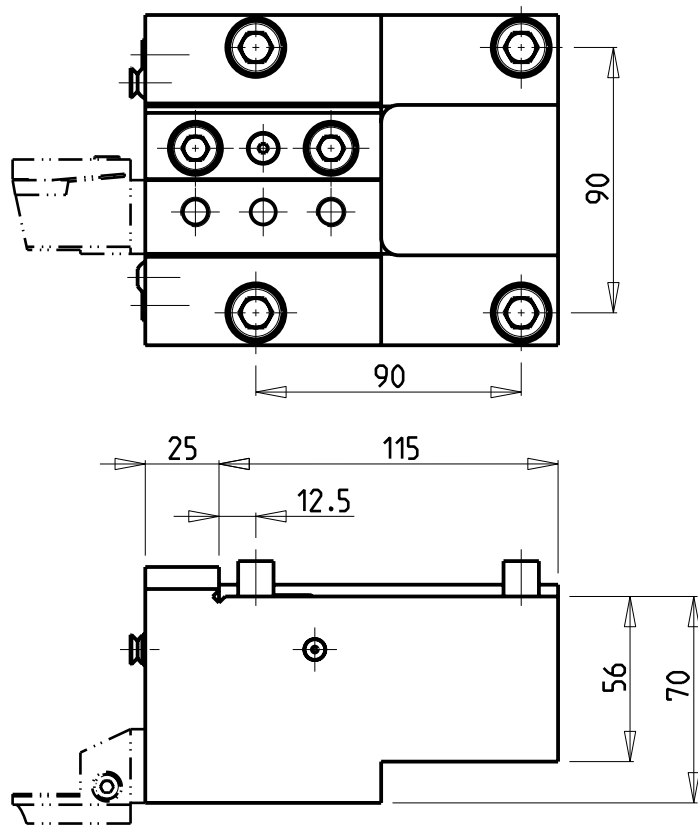

Cod. MT	N°Utensili N°Tools N°Werkzeuge	Reversibile lato mandrino/controlmandrino Reversible sub/main spindle side Umkehrbare Spindel-seite/ Gegenspindel-seite	Misure Dimensions Masse	B	H
0912500	1	X	mm	25	25
0912540	1	X	Inch	1"	1"
0913175	1	X	Inch	1-1/4"	1-1/4"
0913200	1	X	mm	32	32

DOOSAN BMT 75

MOD: PUMA 400 - PUMA 480M/LM/XLM

PORTAUTENSILE ASSIALE SINGOLO

Axial single static tool

Axial Single-Werkzeughalter

**M.T. srl**

Via Casino Albini 480  
Tel. 0541/956034-957884  
Fax 0541/956341  
47842 S. GIOVANNI IN M. (RN)  
e-mail: mtma@mtmarchetti.com  
http://www.mtmarchetti.com

PRODUZIONE MODULI ROTANTI



PAGINA DW 0552-4-00

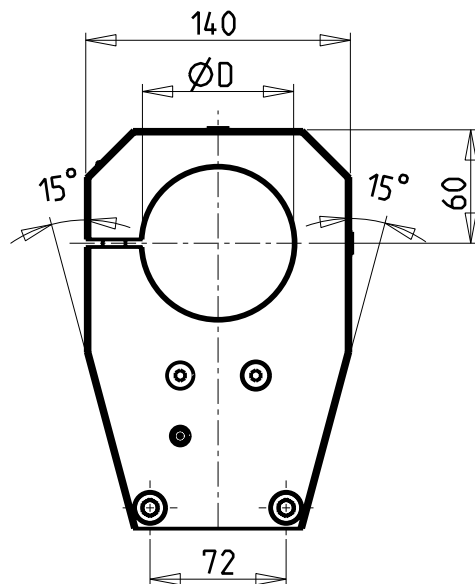
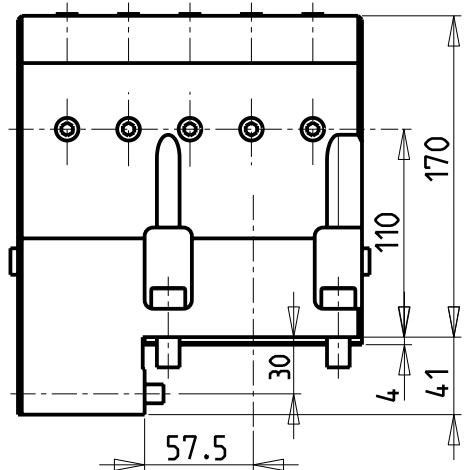
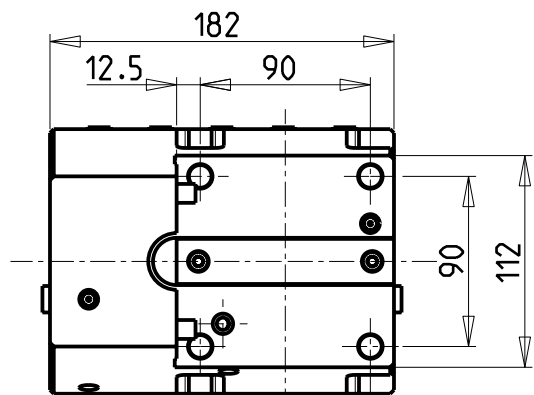

KIT ADDUZIONE INTERNA (OPZIONALE)  
 KIT FOR INTERNAL COOLANT (OPTIONAL)  
 KIT FUER INTERNE KUEHLMITTELZUFUHR (OPTIONAL)  
 Ø80 cod. KIT1005013

SOLO GUARNIZIONE (OPZIONALE)  
 ONLY SEAL (OPTIONAL)  
 NUR DICHTUNG (OPTIONAL)  
 cod. MNL0620002

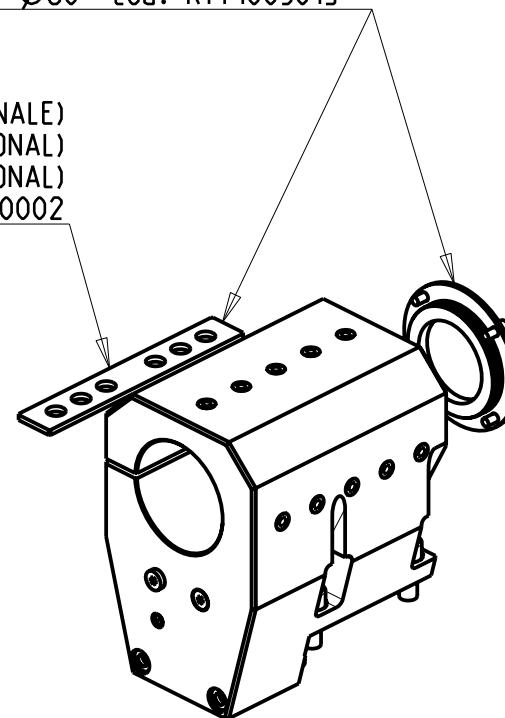

PER BOCCOLE DI RIDUZIONE VEDI PAG. TBL150-1-00  
 FOR REDUCING BUSHINGS SEE PAGE TBL150-1-00  
 FÜR REDUZIERBUCHSE SIEHE SEITE TBL150-1-00

Cod. MT	N°Utensili N°Tools N°Werkzeuge	Lubrificazione int. opzionale Coolant through optional Innenkuehlung Optional	Lubrificazione est. Ext. coolant Aussenkuehlung	Misure Dimensions Masse	D
DW00848000	1	X	X	mm	80

NEW

DOOSAN BMT 75

MOD: PUMA 400 - PUMA 480M/LM/XLM

PORTAUTENSILE ASSIALE PER BARENO Ø80mm H=110mm

Axial single boring bar holder Ø80mm H=110mm

Axial Bohrhälter Ø80mm H=110mm

**M.T. srl**

Via Casino Albini 480  
 Tel. 0541/956034-957884  
 Fax 0541/956341

47842 S. GIOVANNI IN M. (RN)  
 e-mail: mtma@mtmarchetti.com  
 http://www.mtmarchetti.com

PRODUZIONE MODULI ROTANTI



PAGINA DW 0580-4-20

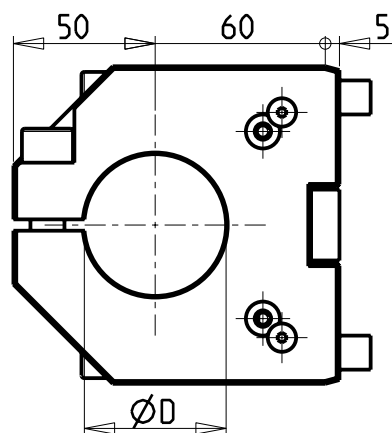
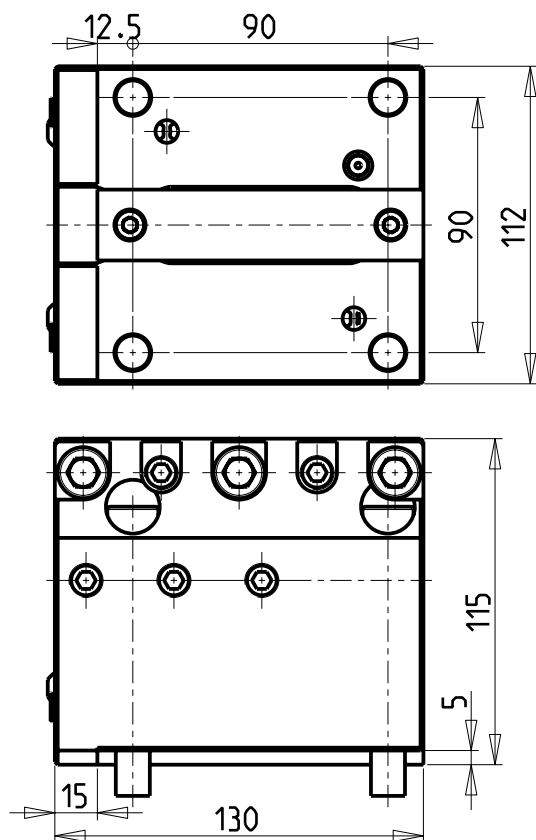

KIT ADDUZIONE INTERNA (OPZIONALE)  
 KIT FOR INTERNAL COOLANT (OPTIONAL)  
 KIT FUER INTERNE KUEHLMITTELZUFUHR (OPTIONAL)  
 Ø1 1/2" cod. KIT1001004  
 Ø40 cod. KIT1001003  
 Ø50-Ø2" cod. KIT1001002

SOLO GUARNIZIONE (OPZIONALE)  
 ONLY SEAL (OPTIONAL)  
 NUR DICHTUNG (OPTIONAL)  
 cod. MNL0110008

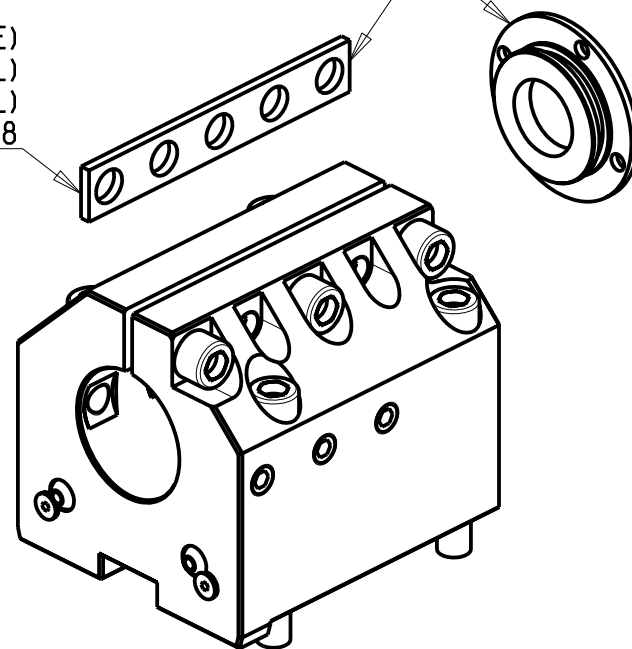

PER BOCCOLE DI RIDUZIONE VEDI PAG. TBL150-1-00  
 FOR REDUCING BUSHINGS SEE PAGE TBL150-1-00  
 FUR REDUZIERBUCHSE SIEHE SEITE TBL150-1-00

Cod. MT	N°Utensili N°Tools N°Werkzeuge	Reversibile lato mandrino/contromandrino Reversible sub/main spindle side Umkehrbare Spindel-seite/ Gegenspindel-seite	Lubrificazione int. opzionale Coolant through optional Innenkuehlung Optional	Lubrificazione est. Ext. coolant Aussenkuehlung	Misure Dimensions Masse	D
DW 00364000	1	X	X	X	mm	40
DW 00363810	1	X	X	X	Inch	1 1/2"
DW 00365000	1	X	X	X	mm	50
DW 00365080	1	X	X	X	Inch	2"

DOOSAN BMT 75

MOD: PUMA 400 - PUMA 480M/LM/XLM

PORTAUTENSILE ASSIALE PER BARENO Ø40mm/Ø1 1/2"/Ø50mm/Ø2" H=60mm

Axial single boring bar holder Ø40mm/Ø1 1/2"/Ø50mm/Ø2" H=60mm

Axial Bohrhalter Ø40mm/Ø1 1/2"/Ø50mm/Ø2" H=60mm

**M.T. srl**

Via Casino Albini 480  
 Tel. 0541/956034-957884  
 Fax 0541/956341  
 47842 S. GIOVANNI IN M. (RN)  
 e-mail: mtma@mtmarchetti.com  
 http://www.mtmarchetti.com

PRODUZIONE MODULI ROTANTI



PAGINA DW 0610-4-20

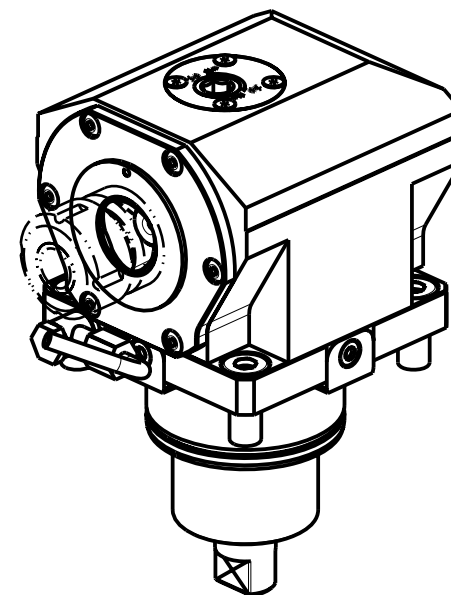
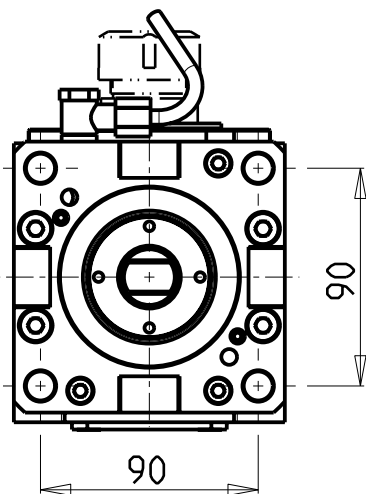
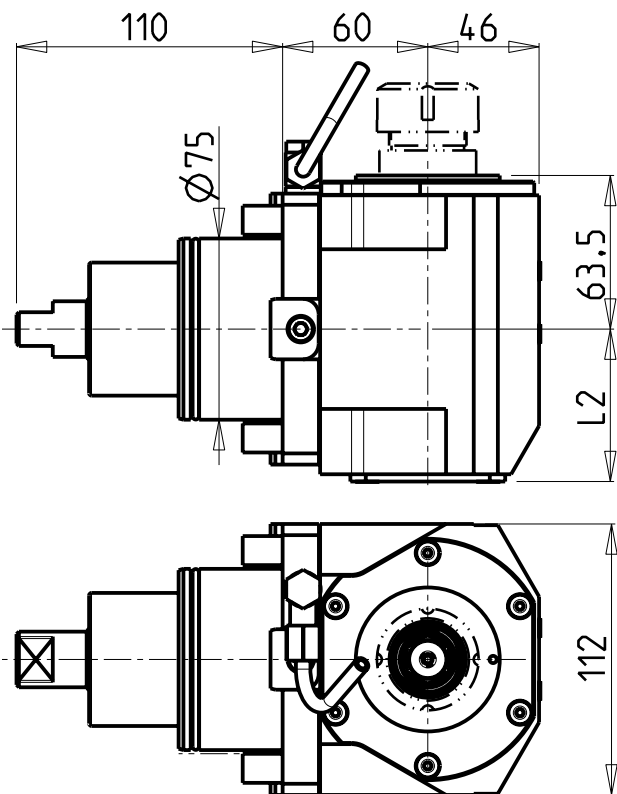

Cod. MT	TAGLIA Size Masse	I	RPM	Coppia Max Max Torque Max Drehmoment	Reversibile lato mandrino/contromandrino Reversible sub/main spindle side Umkehrbare Spindelseite/ Gegenspindelseite	Lubr.interna Coolant through Innenkuehlung	Lubr.esterna Ext. coolant Aussenkuehlung	L2
DW 00610140	C4	1:1	6000	70Nm	X		X	63
DW 00610240	C4	1:1	6000	70Nm	X	P=70bar	X	76.5
DW 00610150	C5	1:1	6000	70Nm	X		X	63
DW 00610250	C5	1:1	6000	70Nm	X	P=70bar	X	76.5

## DOOSAN BMT 75

MOD: PUMA 400 - PUMA 480M/LM/XLM - VT 750M/TM

MODULO MOTORIZZATO ASSIALE COROMANT CAPTO®

Axial driven tool COROMANT CAPTO®

Axial angetriebenes Werkzeug COROMANT CAPTO®

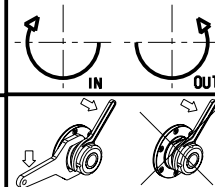

### M.T. srl

Via Casino Albini 480  
Tel. 0541/956034-957884

Fax 0541/956341

47842 S. GIOVANNI IN M. (RN)

e-mail: mtma@mtmarchetti.com

http://www.mtmarchetti.com

PRODUZIONE MODULI ROTANTI



PAGINA DW 0150-D-40

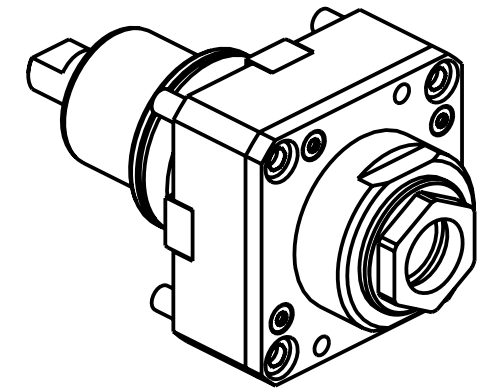
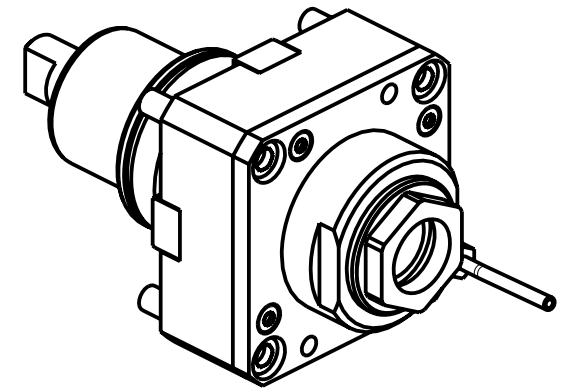
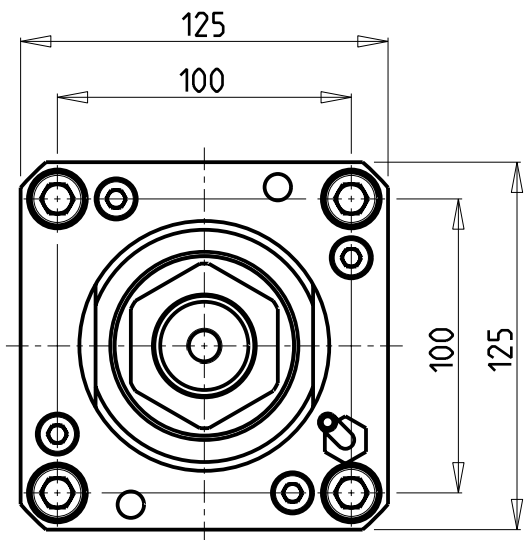
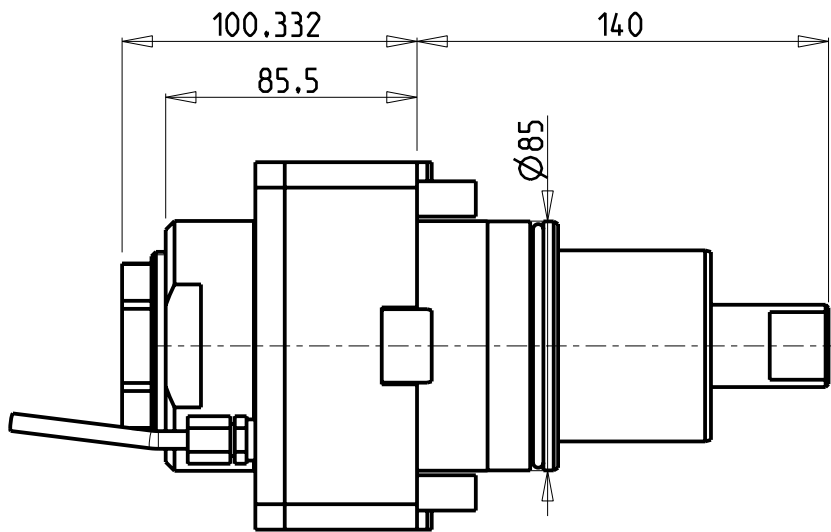

Cod. MT	Mandrino Spindle Spindel	I	RPM	Coppia Max Max Torque Max Drehmoment	Lubrificazione int. Coolant through Innenkuehlung	Lubrificazione est. Ext. coolant Aussenkuehlung	CHIAVI NON INCLUSE Keys not included Schluessel nicht einbegriffen	
DW 00160150	ER A 50	1:1	3000	210Nm		X	CHUB50	CHUB74
DW 00160250	ER A 50	1:1	3000	210Nm	P=30bar	X	CHUB50	CHUB74

DOOSAN BMT 85  
 MOD: VT900M/TM - VT1100M - PUMA 600M/LM - PUMA 700M/LM - PUMA 800M/LM  
 MODULO MOTORIZZATO RADIALE  
 Radial driven tool  
 Radial angetriebenes Werkzeug

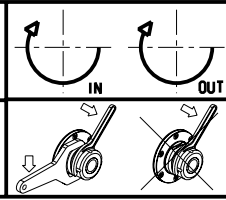

**M.T. srl**  
 Via Casino Albini 480  
 Tel. 0541/956034-957884  
 Fax 0541/956341  
 47842 S. GIOVANNI IN M. (RN)  
 e-mail: mtma@mtmarchetti.com  
 http://www.mtmarchetti.com

PRODUZIONE MODULI ROTANTI

PAGINA DW 0010-5-00



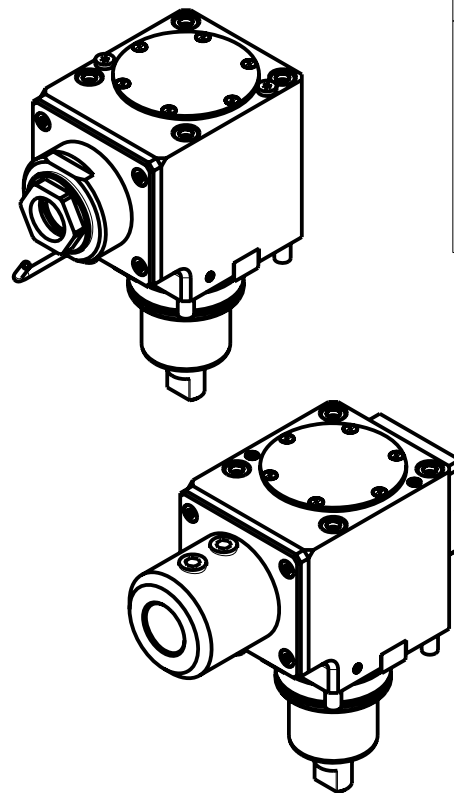
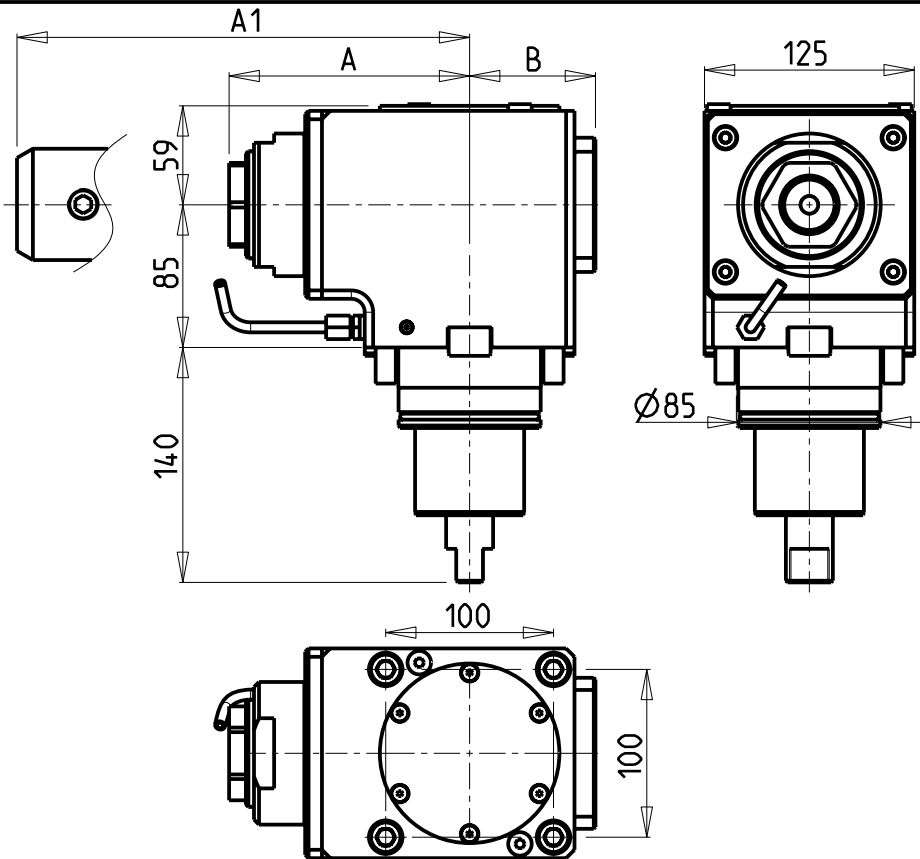

### ATTENZIONE - ATTENTION - ACHTUNG

- IL MOTORIZZATO COD. "DW00150250" NON SI PUO' MONTARE SULLE MACCHINE VT900M/TM-VT1100M. CONTATTARE UFFICIO TECNICO
- DRIVEN TOOL WITH PART NUMBER "DW00150250" CAN NOT BE MOUNTED ON THE FOLLOWING MACHINES: VT900M/TM-VT1100M PLEASE CONTACT OUR TECHNICAL DEPARTMENT
- ANGETRIEBENES WERKZEUG "DW00150250" KANN MAN NICHT AUF DEN VT900M/TM-VT1100M MASCHINEN MONTIEREN. BITTE DAS TECHNISCHE BUERO KONTAKTIEREN

### ATTENZIONE - ATTENTION - ACHTUNG

- Su macchina VT1100M non arrivano in centro mandrino
- On machine VT1100M tool does not get to the centre of the spindle axis.
- Auf Maschinen VT1100M erreicht das Werkzeug nicht die Mitte der Werkzeug-Achse.

Cod. MT	Mandrino Spindle Spindel	I	RPM	Coppia Max Max Torque Max Drehmoment	Reversibile lato mandrino/contromandrino Reversible sub/main spindle side Umkehrbare Spindel-seite/ Gegenspindel-seite	Lubr.interna Coolant through Innenkuehlung	Lubr. esterna Ext. coolant Aussenkuehlung	A	A1	B	CHIAVI NON INCLUSE Keys not included Schluessel nicht einbegriffen	
DW 00150150	ER A 50	1:1	3000	210Nm	X		X	143.33	-	75	CHUB50	CHUB74
DW 00150250	ER A 50	1:1	3000	210Nm	X	P=70bar	X	143.33	-	91	CHUB50	CHUB74
DW 00151250	ER A 50	1:1	3000	210Nm	X	P=70bar	X	143.33	-	86	CHUB50	CHUB74
DW 00150240	Weldon 40	1:1	3000	210Nm	X		X	-	175.5	75	-	-
DW 00150140	Weldon 40	1:1	3000	210Nm	X	P=70bar	X	-	175.5	86	-	-

NEW

DOOSAN BMT 85

MOD: VT900M/TM - VT1100M - PUMA 600M/LM - PUMA 700M/LM - PUMA 800M/LM

MODULO MOTORIZZATO ASSIALE H=85mm

Axial driven tool H=85mm

Axial angetriebenes Werkzeug H=85mm

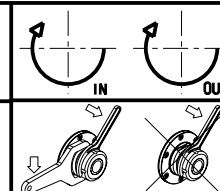

**M.T. srl**

Via Casino Albini 480  
Tel. 0541/956034-957884

Fax 0541/956341

47842 S. GIOVANNI IN M. (RN)

e-mail: mtma@mtmarchetti.com

http://www.mtmarchetti.com

PRODUZIONE MODULI ROTANTI



PAGINA DW 0150-5-10

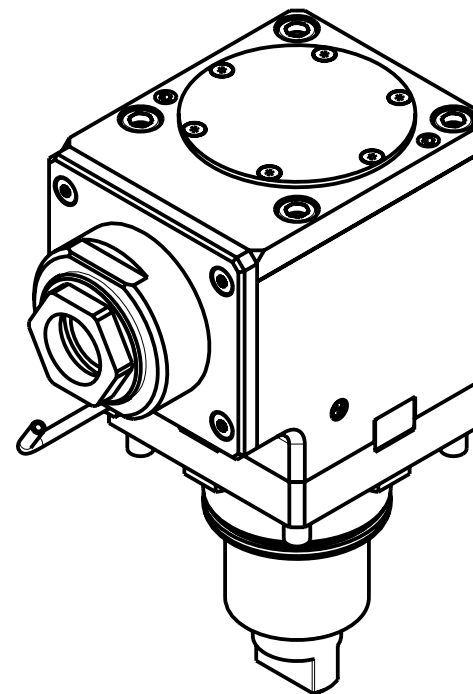
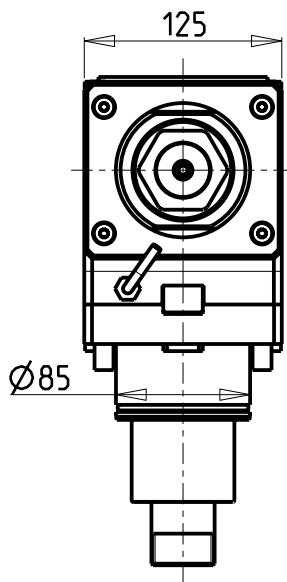
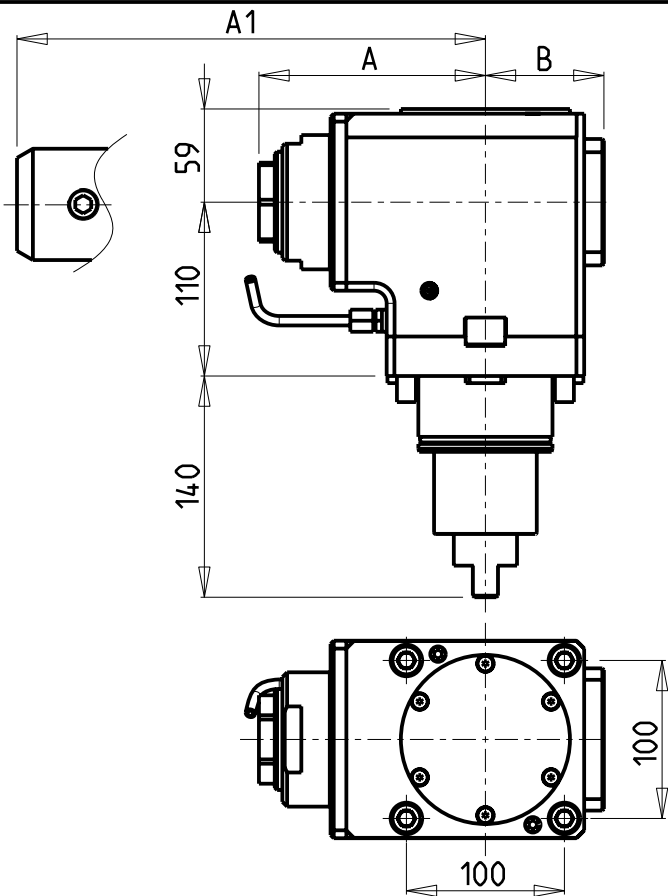

Cod. MT	Mandrino Spindel	I	RPM	Coppia Max Max Torque Max Drehmoment	Reversibile lato mandrino/contromandrino Reversible sub/main spindle side Umkehrbare Spindelseite/ Gegenspindelseite	Lubr.interna Coolant through Innenkuehlung	Lubr. esterna Ext. coolant Aussenkuehlung	A	A1	B	CHIAVI NON INCLUSE Keys not included Schluessel nicht einbegriffen	
DW 01290150	ER A 50	1:1	3000	210Nm	X		X	143.33	-	75	CHUB50	CHUB74
DW 01291250	ER A 50	1:1	3000	210Nm	X	P=70bar	X	143.33	-	86	CHUB50	CHUB74
DW 01290240	Weldon 40	1:1	3000	210Nm	X		X	-	175.5	75	-	-
DW 01290140	Weldon 40	1:1	3000	210Nm	X	P=70bar	X	-	175.5	86	-	-

NEW  
NEW  
NEW  
NEW

### DOOSAN BMT 85

MOD: VT900M/TM - VT1100M - PUMA 600M/LM - PUMA 700M/LM - PUMA 800M/LM

MODULO MOTORIZZATO ASSIALE H=110mm

Axial driven tool H=110mm

Axial angetriebenes Werkzeug H=110mm

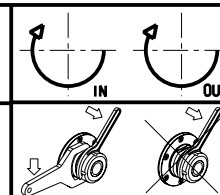

**M.T. srl**

Via Casino Albini 480  
Tel. 0541/956034-957884  
Fax 0541/956341

47842 S. GIOVANNI IN M. (RN)  
e-mail: mtma@mtmarchetti.com  
http://www.mtmarchetti.com

PRODUZIONE MODULI ROTANTI



PAGINA DW 0150-5-20

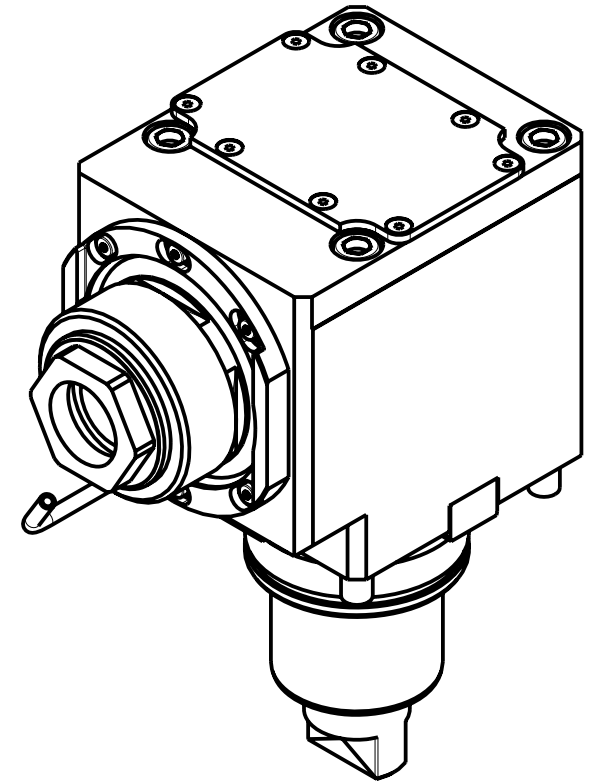
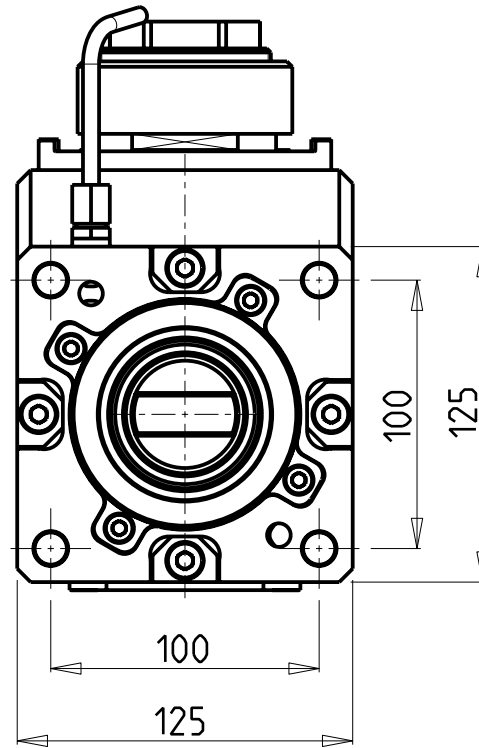
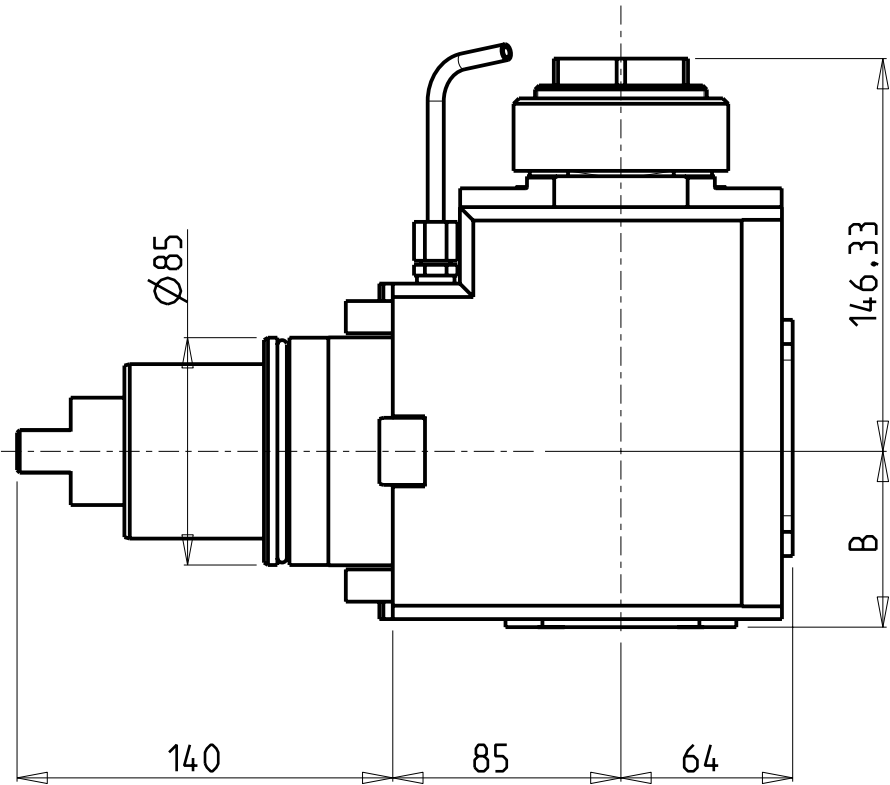

Cod. MT	Mandrino Spindle Spindel	I	RPM	Coppia Max Max Torque Max Drehmoment	Reversibile lato mandrino/contromandrino Reversible sub/main spindle side Umkehrbare Spindel-seite/ Gegen-spindel-seite	Lubrificazione int. Coolant through Innenkuhlung	Lubrificazione est. Ext. coolant Aussenkuhlung	B	CHIAVI NON INCLUSE Keys not included Schlüssel nicht einbegriffen		
DW00460150	ER A 50	2:1	1500	300Nm	X		X	65.5	CHUB50	NZL0010023 •	NEW
DW00460250	ER A 50	2:1	1500	300Nm	X	P=70bar	X	82	CHUB50	NZL0010023 •	NEW

• Chiave inclusa
• Key included
• Schlüssel inbegriffen

DOOSAN BMT 85  
 MOD: VT900M/TM - VT1100M - PUMA 600M/LM - PUMA 700M/LM - PUMA 800M/LM

MODULO MOTORIZZATO ASSIALE RIDOTTO I=2:1 H=85mm  
 Axial geared-down I=2:1 driven tool H=85mm  
 Axial angetriebenes Werkzeug untersetzt I=2:1 H=85mm

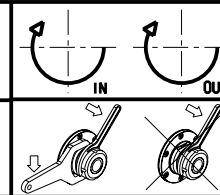

**M.T. srl**  
 Via Casino Albini 480  
 Tel. 0541/956034-957884  
 Fax 0541/956341  
 47842 S. GIOVANNI IN M. (RN)  
 e-mail: mtma@mtmarchetti.com  
 http://www.mtmarchetti.com

PRODUZIONE MODULI ROTANTI



PAGINA DW 0190-5-10

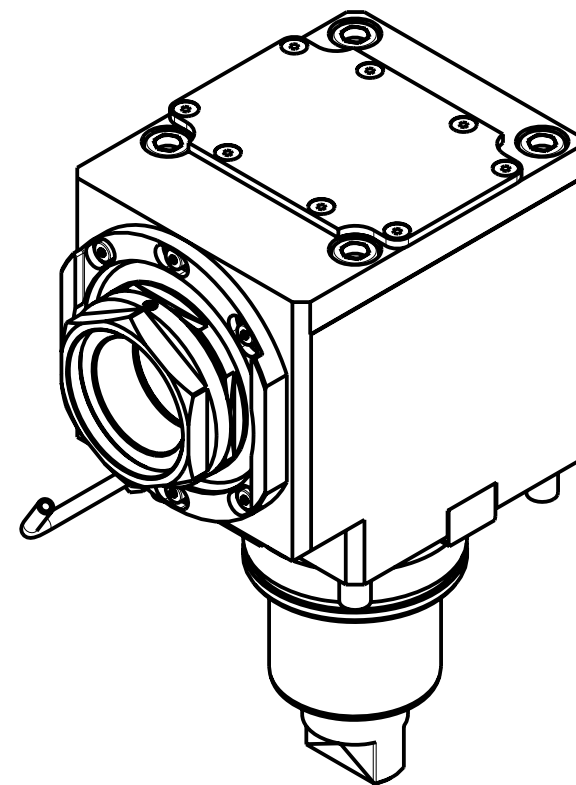
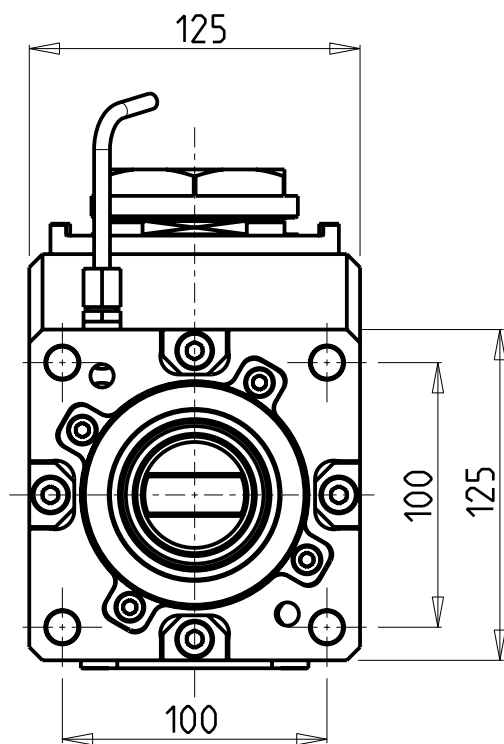
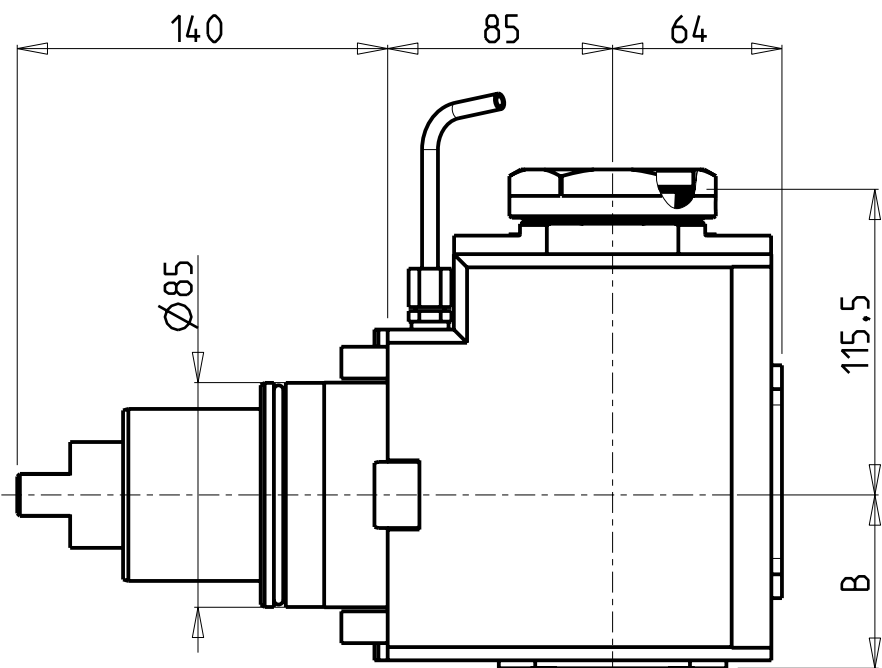

PER PORTAUTENSILI MODULARI MTSK-63 VEDI PAG. TBL300-1-63  
 FOR MTSK-63 QUIK CHANGE TOOLHOLDERS CLAMPINGS SEE PAGE TBL300-1-63  
 FUER MTSK-63 MODULARE WERKZEUGAUFNAHMEN SIEHE SEITE TBL300-1-63

Cod. MT	Mandrino Spindle Spindel	I	RPM	Coppia Max Max Torque Max Drehmoment	Reversibile lato mandrino/contromandrino Reversible sub/main spindle side Umkehrbare Spindel-seite/ Gegenspindel-seite	Lubrificazione int. Coolant through Innenkühlung	Lubrificazione est. Ext. coolant Aussenkühlung	B	CHIAVI NON INCLUSE Keys not included Schlüssel nicht einbegriffen	
DW00760163	MTSK-63	2:1	1500	300Nm	X		X	65.5	CHUB68	NZL0010023 •
DW00760263	MTSK-63	2:1	1500	300Nm	X	P=70bar	X	82	CHUB68	NZL0010023 •

- Chiave inclusa
- Key included
- Schlüssel inbegriffen

NEW  
NEW

DOOSAN BMT 85  
 MOD: VT900M/TM - VT1100M - PUMA 600M/LM - PUMA 700M/LM - PUMA 800M/LM

MODULO MOTORIZZATO ASSIALE MTSK RIDOTTO I=2:1 H=85mm  
 Axial MTSK geared-down I=2:1 driven tool H=85mm  
 Axial MTSK angetriebenes Werkzeug untersetzt I=2:1 H=85mm

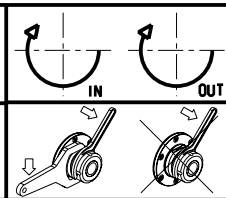

**M.T. srl**  
 Via Casino Albini 480  
 Tel. 0541/956034-957884  
 Fax 0541/956341  
 47842 S. GIOVANNI IN M. (RN)  
 e-mail: mtma@mtmarchetti.com  
 http://www.mtmarchetti.com

PRODUZIONE MODULI ROTANTI



PAGINA DW 0190-5-10-K

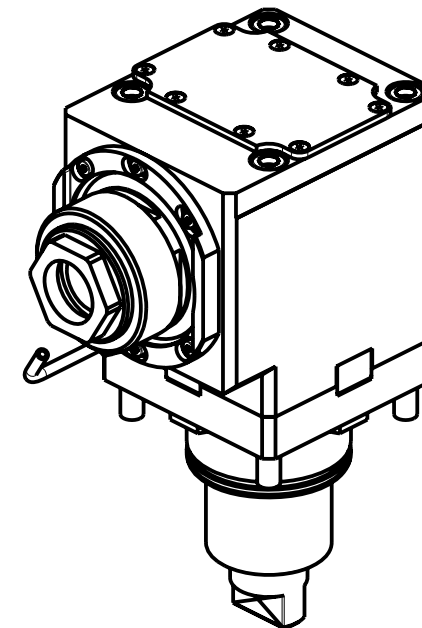
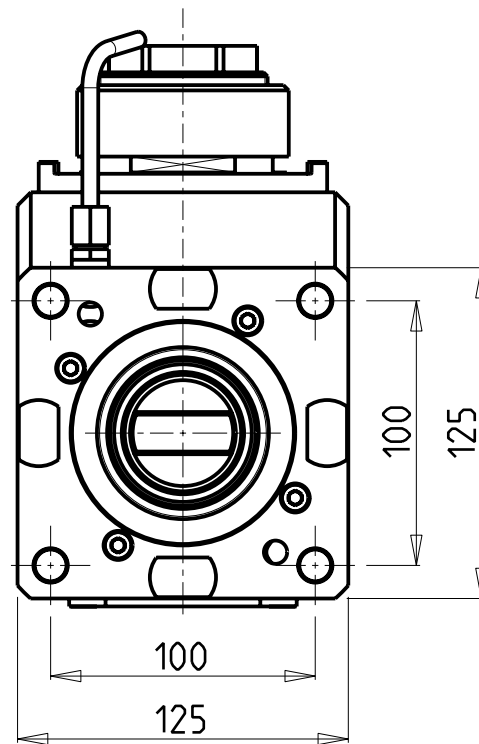
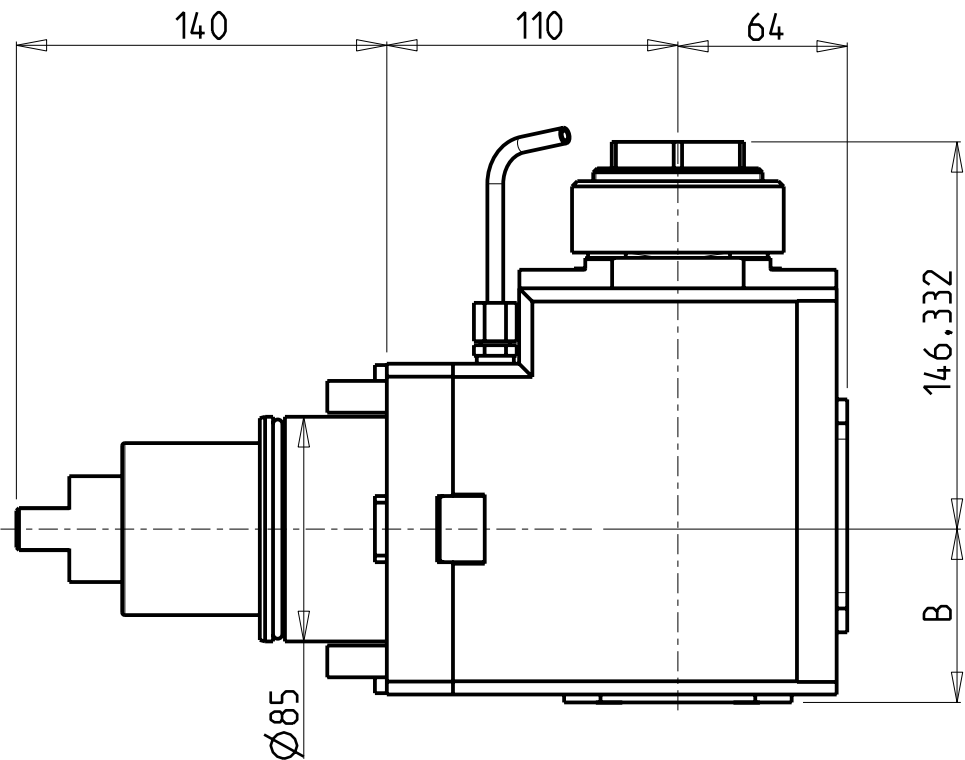

Cod. MT	Mandrino Spindle Spindel	I	RPM	Coppia Max Max Torque Max Drehmoment	Reversibile lato mandrino/contromandrino Reversible sub/main spindle side Umkehrbare Spindel-seite/ Gegenspindel-seite	Lubrificazione int. Coolant through Innenkühlung	Lubrificazione est. Ext. coolant Aussenkühlung	B	CHIAVI NON INCLUSE Keys not included Schlüssel nicht einbegriffen	
DW 01210150	ER A 50	2:1	1500	300Nm	X		X	65.5	CHUB50	NZL0010023 •
DW 01210250	ER A 50	2:1	1500	300Nm	X	P=70bar	X	82	CHUB50	NZL0010023 •

• Chiave inclusa
• Key included
• Schlüssel inbegriffen

NEW  
NEW

DOOSAN BMT 85

MOD: VT900M/TM - VT1100M - PUMA 600M/LM - PUMA 700M/LM - PUMA 800M/LM

MODULO MOTORIZZATO ASSIALE RIDOTTO I=2:1 H=110mm

Axial geared-down I=2:1 driven tool H=110mm

Axial angetriebenes Werkzeug untersetzt I=2:1 H=110mm

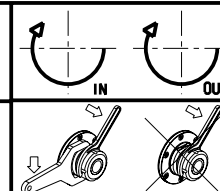

**M.T. srl**

Via Casino Albini 480  
Tel. 0541/956034-957884  
Fax 0541/956341

47842 S. GIOVANNI IN M. (RN)  
e-mail: mtma@mtmarchetti.com  
http://www.mtmarchetti.com

PRODUZIONE MODULI ROTANTI



PAGINA DW 0190-5-20

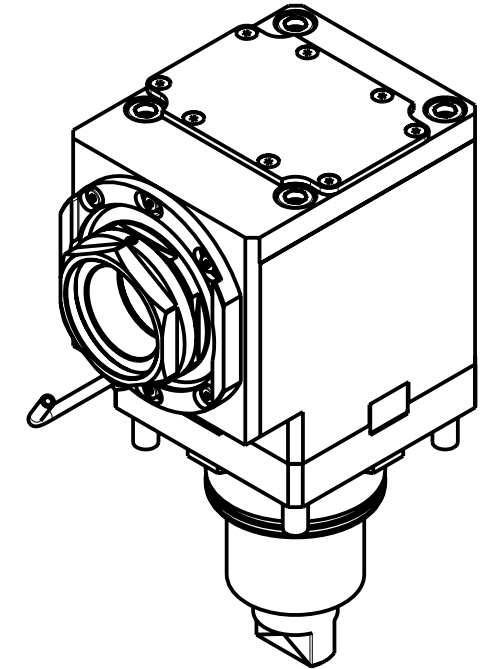
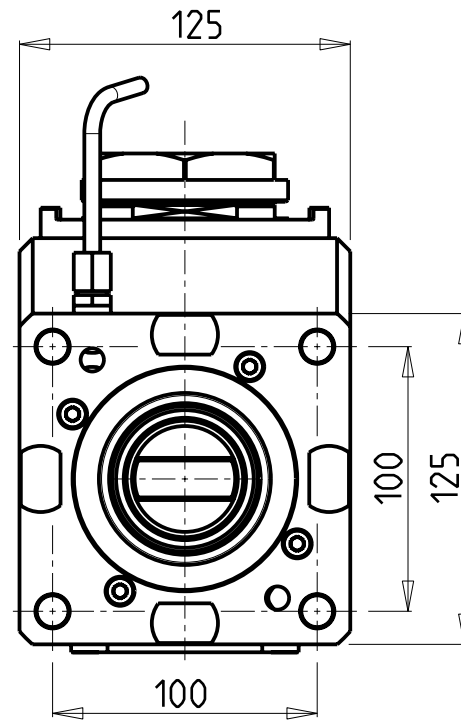
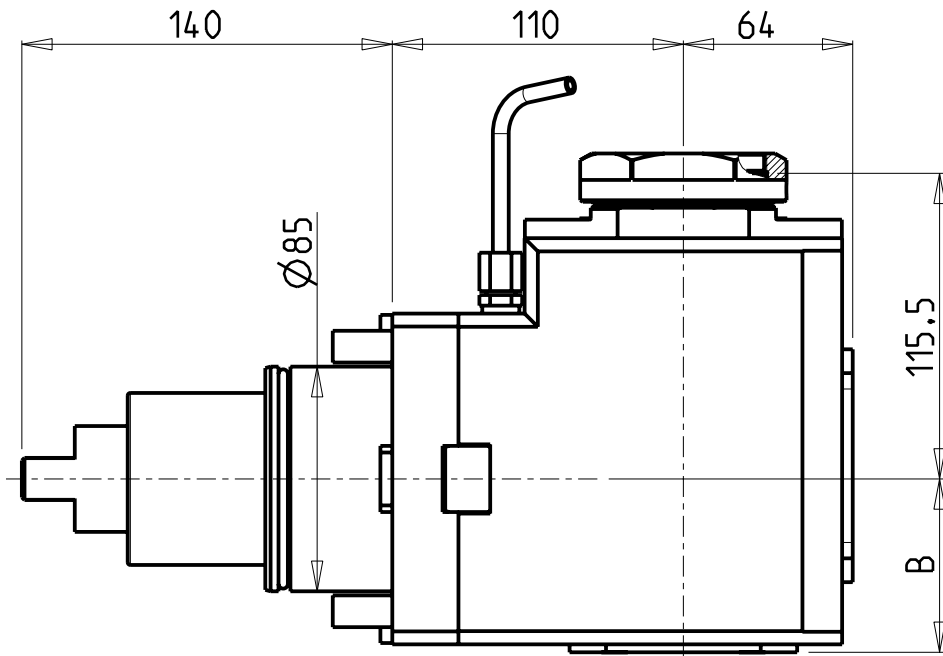

PER PORTAUTENSILI MODULARI MTSK-63 VEDI PAG. TBL300-1-63  
 FOR MTSK-63 QUICK CHANGE TOOLHOLDERS CLAMPINGS SEE PAGE TBL300-1-63  
 FÜR MTSK-63 MODULARE WERKZEUGAUFNAHMEN SIEHE SEITE TBL300-1-63

Cod. MT	Mandrino Spindle Spindel	I	RPM	Coppia Max Max Torque Max Drehmoment	Reversibile lato mandrino/contromandrino Reversible sub/main spindle side Umkehrbare Spindel-seite/ Gegenspindel-seite	Lubrificazione int. Coolant through Innenkühlung	Lubrificazione est. Ext. coolant Aussenkühlung	B	CHIAVI NON INCLUSE Keys not included Schlüssel nicht einbegriffen		
DW01200163	MTSK-63	2:1	1500	300Nm	X		X	65.5	CHUB68	NZL0010023 •	NEW
DW01200263	MTSK-63	2:1	1500	300Nm	X	P=70bar	X	82	CHUB68	NZL0010023 •	NEW

- Chiave inclusa
- Key included
- Schlüssel inbegriffen

DOOSAN BMT 85  
 MOD: VT900M/TM - VT1100M - PUMA 600M/LM - PUMA 700M/LM - PUMA 800M/LM

MODULO MOTORIZZATO ASSIALE MTSK RIDOTTO I=2:1 H=110mm  
 Axial MTSK geared-down I=2:1 driven tool H=110mm  
 Axial MTSK angetriebenes Werkzeug untersetzt I=2:1 H=110mm

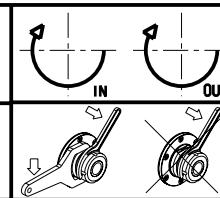

**M.T. srl**  
 Via Casino Albini 480  
 Tel. 0541/956034-957884  
 Fax 0541/956341  
 47842 S. GIOVANNI IN M. (RN)  
 e-mail: mtma@mtmarchetti.com  
 http://www.mtmarchetti.com

PRODUZIONE MODULI ROTANTI



PAGINA DW0190-5-20-K

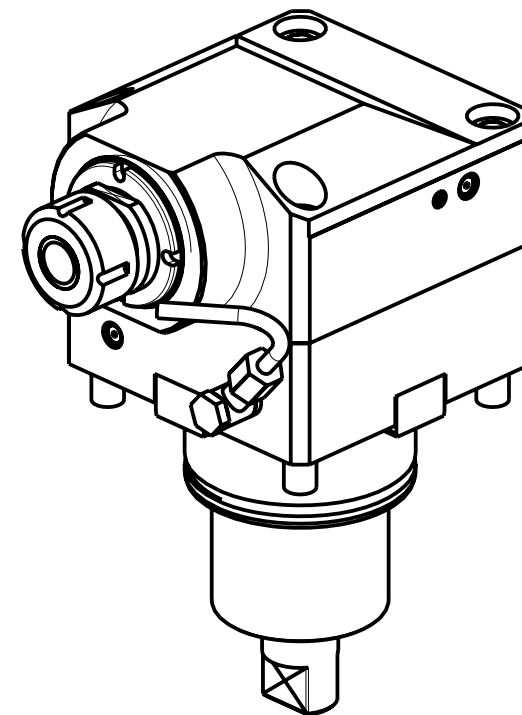
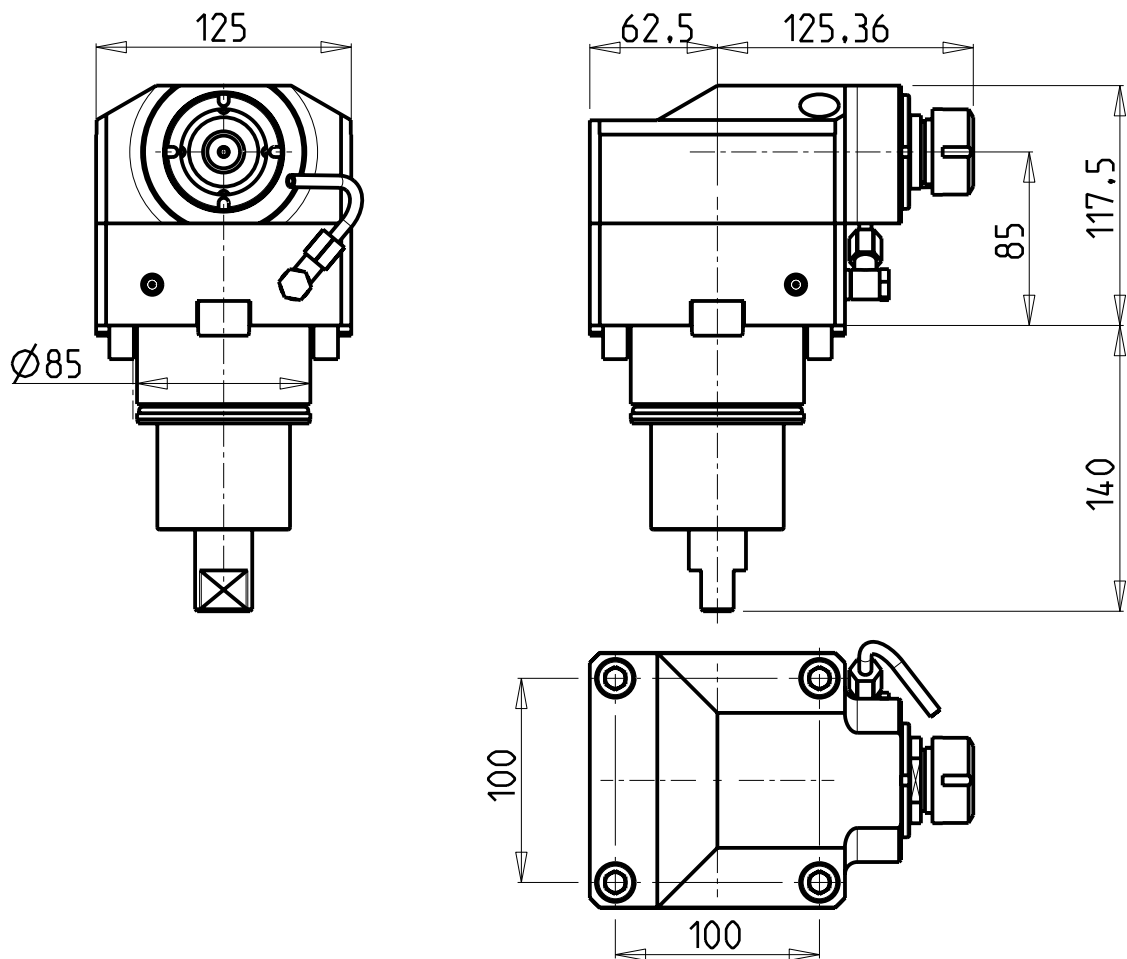

Cod. MT	Mandrino Spindle	I	RPM MAX	Coppia Max Max Torque Max Drehmoment	Lubrificazione int. Coolant through Innenkuehlung	Lubrificazione est. Ext. coolant Aussenkuehlung	CHIAVI NON INCLUSE Keys not included Schlüssel nicht einbegriffen	
							CHSTER25	CHUB36
DW00580125	ER25	1:3	9000	70Nm		X	CHSTER25	CHUB36
DW00580225	ER25	1:3	9000	70Nm	P=70bar	X	CHSTER25	CHUB36

DOOSAN BMT 85

MOD: VT900M/TM - VT1100M - PUMA 600M/LM - PUMA 700M/LM - PUMA 800M/LM

MODULO MOTORIZZATO ASSIALE MOLTIPLICATO I=1:3

Axial geared-up I=1:3 driven tool

Axial angetriebenes Werkzeug uebersetzt I=1:3

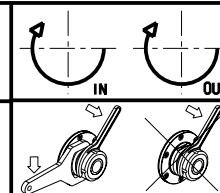

**M.T. srl**

Via Casino Albini 480  
Tel. 0541/956034-957884  
Fax 0541/956341

47842 S. GIOVANNI IN M. (RN)  
e-mail: mtma@mtmarchetti.com  
http://www.mtmarchetti.com

PRODUZIONE MODULI ROTANTI



PAGINA DW 0205-5-10

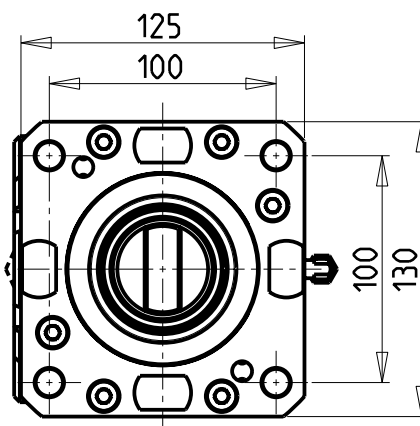
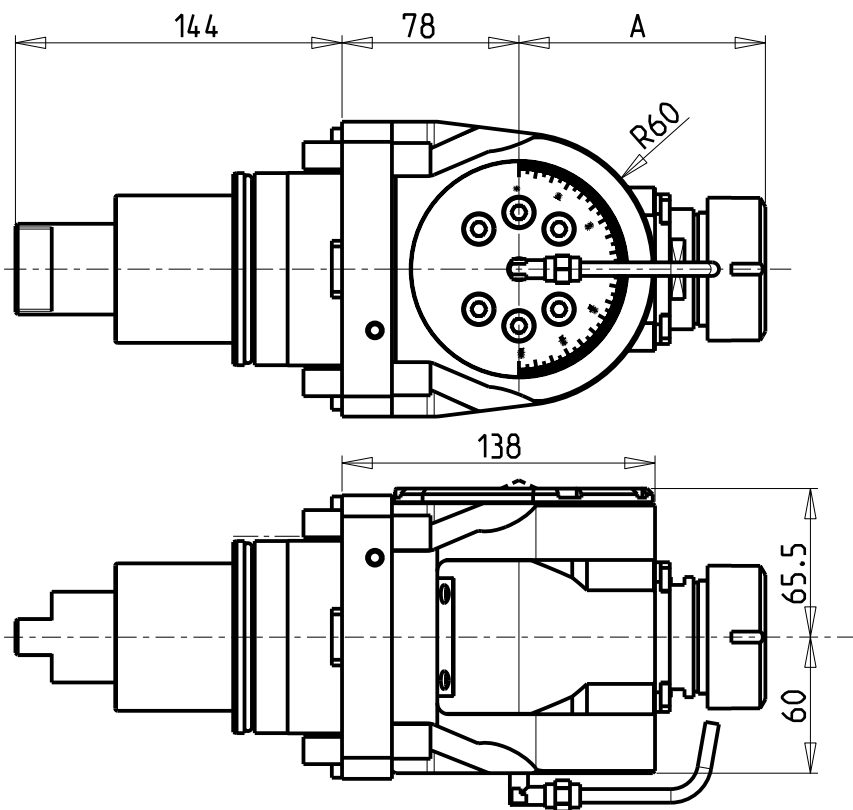

### ATTENZIONE - ATTENTION - ACHTUNG

- Per lo smontaggio degli utensili utilizzare sempre la chiave di contrasto come indicato nel manuale d'uso.
- For disassembly of the tools use always the contrast key as mentioned in the user instructions.
- Fuer das Abmontieren der Werkzeuge immer den Gegenschlüssel benutzen wie in der Bedienungsanleitung erwäehnt.

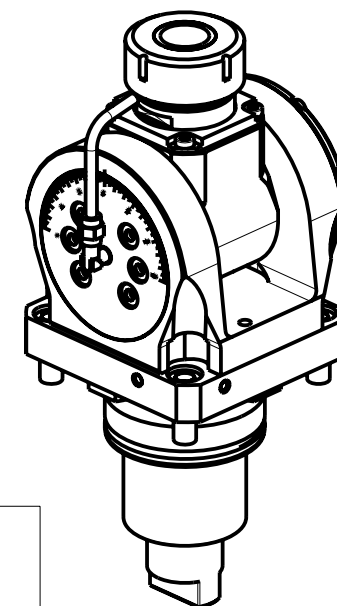

Cod. MT	Mandrino Spindel Spindel	I	RPM	Coppia Max Max Torque Max Drehmoment	Lubrificazione int. Coolant through Innenkuehlung	Lubrificazione est. Ext. coolant Aussenkuehlung	A	CHIAVI INCLUSE Keys included Schlüssel inbegriffen					
DW 00830332	ERA32	1:1	3000	50Nm		X	81	CHUB30	CHUB46	CHTAER32ZC	CHESL10	CHESL06	NEW
DW 00830432	ERA32	1:1	3000	50Nm	P=70bar	X	81	CHUB30	CHUB46	CHTAER32ZC	CHESL10	CHESL06	NEW
DW 00830140	ER40	1:1	3000	50Nm		X	108.66	-	CHUB46	CHSTER40	CHESL10	CHESL06	NEW
DW 00830240	ER40	1:1	3000	50Nm	P=70bar	X	108.66	-	CHUB46	CHSTER40	CHESL10	CHESL06	NEW

DOOSAN BMT 85

MOD: VT900M/TM - VT1100M - PUMA 600M/LM - PUMA 700M/LM - PUMA 800M/LM

MODULO MOTORIZZATO ORIENTABILE +/-90°

+/-90° adjustable angle driven tool

Angetriebenes Werkzeug schwenkbar +/-90°

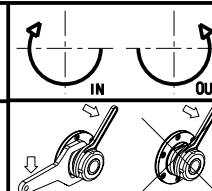

**M.T. srl**

Via Casino Albini 480  
Tel. 0541/956034-957884

Fax 0541/956341

47842 S. GIOVANNI IN M. (RN)

e-mail: mtma@mtmarchetti.com

http://www.mtmarchetti.com

PRODUZIONE MODULI ROTANTI



PAGINA DW 0339-5-00



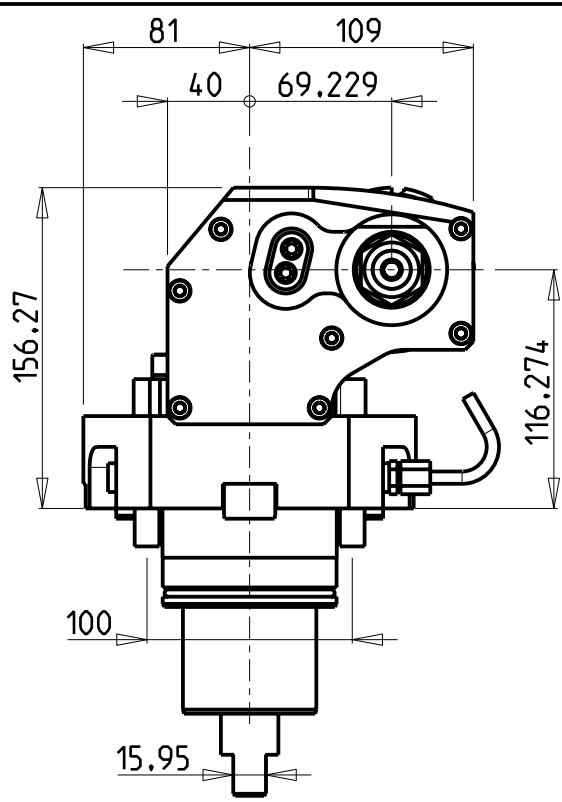
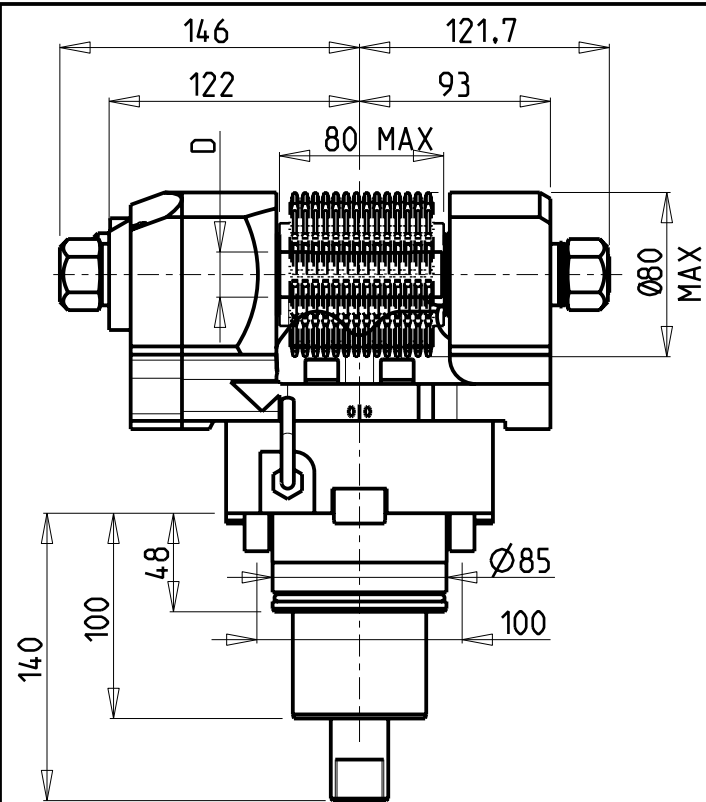

INCLINAZIONE  
REGOLABILE ±30°

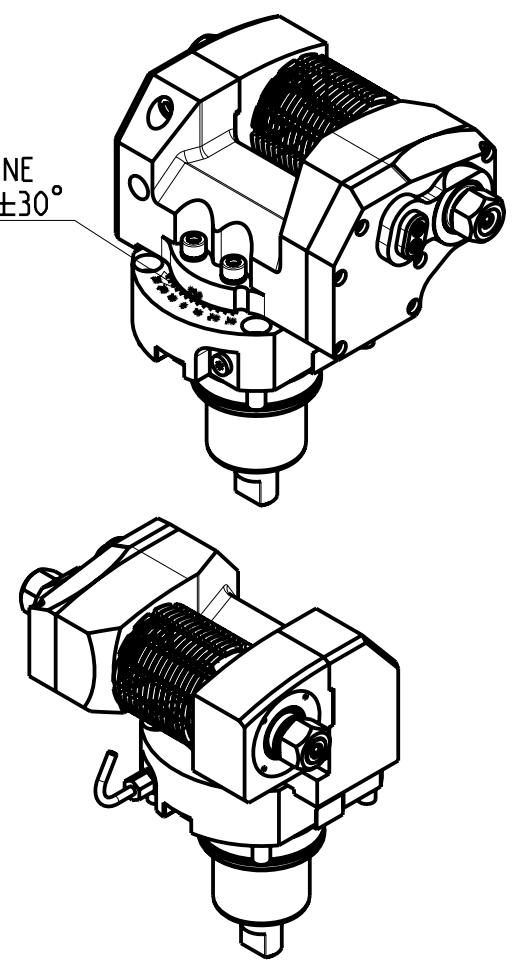

**DOTAZIONI - SUPPLIED WITH - AUSSTATTUNG**

- |           |   |
|-----------|---|
| mm / inch | - N°1 ALBERO + DISTANZIALI<br>- N°1 SHAFT + SPACER<br>- N°1 DORN + ABSTANDSSTUECK |
|-----------|---|

PER ALBERI E DISTANZIALI VEDI PAG. TBL250-1-00  
FOR SHAFT END SPACER SEE PAGE TBL250-1-00  
FUER DORN UND ABSTANDSSTUECK SEITE TBL250-1-00

Cod. MT	I	RPM max	Coppia Max Max Torque Max Drehmoment	Lubrificazione est. Ext. coolant Aussenkuehlung	D (mm)	D (Inch)	CHIAVI INCLUSE Keys included Schlüssel inbegriffen			
							CHUB30	CHESL08	CHESL10	CHUB24 (Ø16 / Ø3/4")
DW 00181100	1:1	3000	90Nm	X	16-22-27-32	3/4"-1"-1 1/4"	CHUB30	CHESL08	CHESL10	CHUB24 (Ø16 / Ø3/4")
DW 00182100	2:1	1500	110Nm	X	16-22-27-32	3/4"-1"-1 1/4"	CHUB30	CHESL08	CHESL10	CHUB24 (Ø16 / Ø3/4")

DOOSAN BMT 85  
MOD: VT900M/TM - VT1100M - PUMA 600M/LM - PUMA 700M/LM - PUMA 800M/LM

MODULO MOTORIZZATO PORTACREATORE MAGGIORATO  
Reinforced driven gear hobber  
Angetriebenes Zahnradwaelzfraes-Werkzeug vergroessert

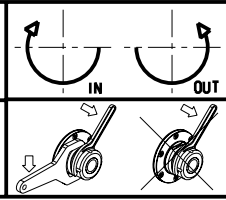

**M.T. srl**  
Via Casino Albini 480  
Tel. 0541/956034-957884  
Fax 0541/956341  
47842 S. GIOVANNI IN M. (RN)  
e-mail: mtma@mtmarchetti.com  
http://www.mtmarchetti.com

PRODUZIONE MODULI ROTANTI

PAGINA DW 0340-5-60

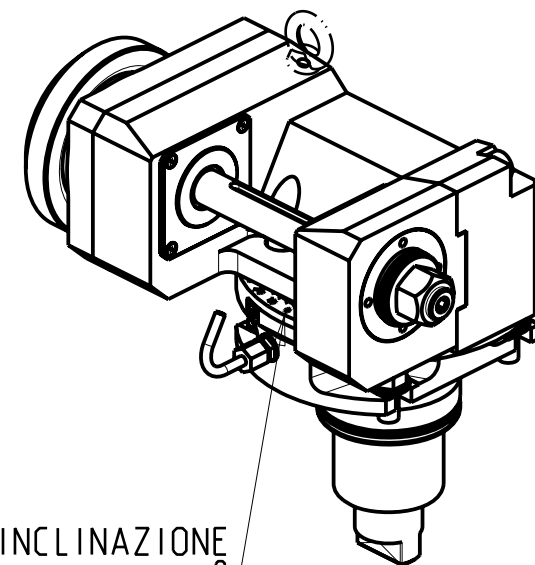
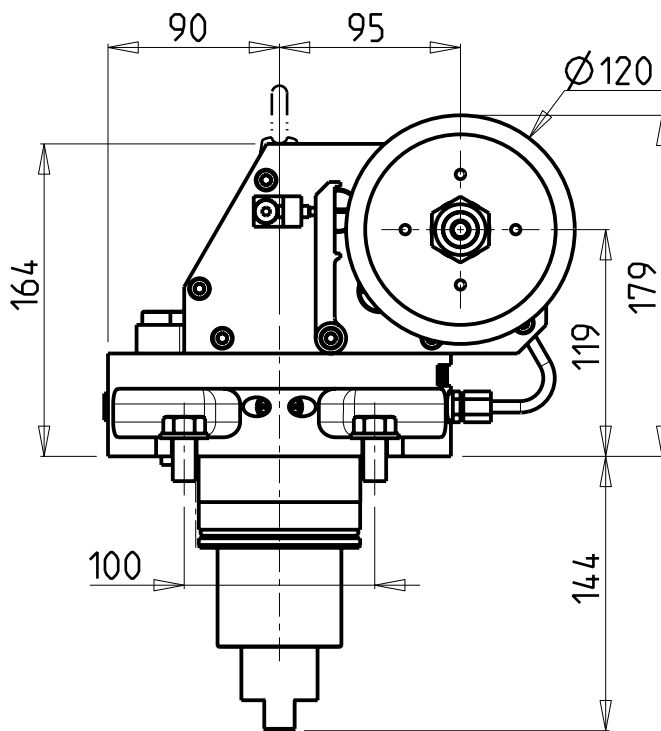
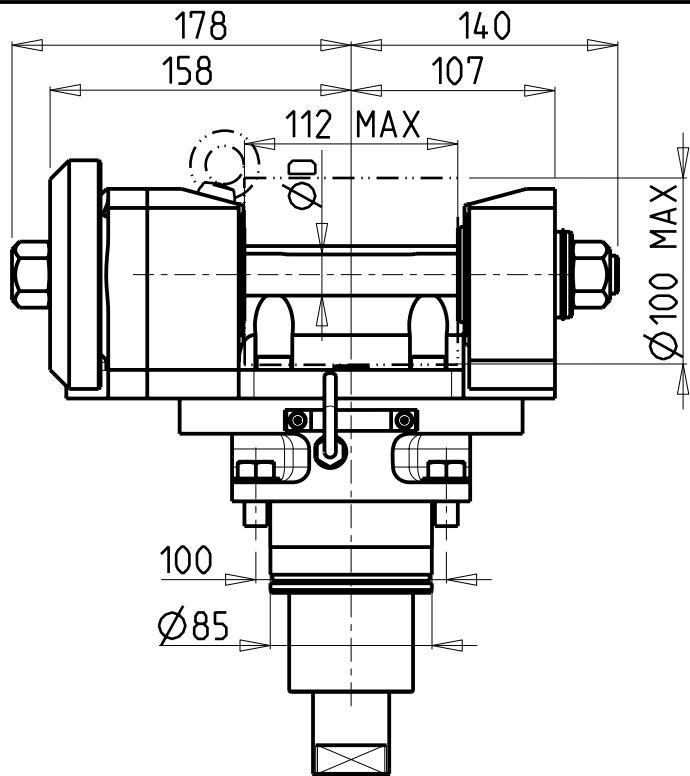

INCLINAZIONE  
REGOLABILE  $\pm 180^\circ$

**DOTAZIONI - SUPPLIED WITH - AUSSTATTUNG**

mm / inch

- N°1 ALBERO + DISTANZIALI
- N°1 SHAFT + SPACER
- N°1 DORN + ABSTANDSSTUECK

PER ALBERI E DISTANZIALI VEDI PAG. TBL250-1-00  
FOR SHAFT END SPACER SEE PAGE TBL250-1-00  
FUER DORN UND ABSTANDSSTUECK SEITE TBL250-1-00

Cod. MT	I	RPM MAX	Coppia Max Max Torque Max Drehmoment	Lubrificazione est. Ext. coolant Aussenkuehlung	D (mm)	CHIAVI INCLUSE Keys included Schluessel inbegriffen				
						CHUB30	CHESL08	CHESL10	CHUB19	
DW00851100	1:1	3000	110Nm	X	22-27-32	CHUB30	CHESL08	CHESL10	CHUB19	NEW
DW00852100	2:1	1500	130Nm	X	22-27-32	CHUB30	CHESL08	CHESL10	CHUB19	NEW

DOOSAN BMT 85

MOD: VT900M/TM - VT1100M - PUMA 600M/LM - PUMA 700M/LM - PUMA 800M/LM

MODULO MOTORIZZATO PORTACREATORE (TAGLIA GRANDE)

Driven gear hobber (big size)

Angetriebenes Zahnradwaelzfraes-Werkzeug (grosse version)

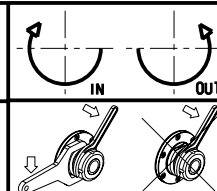

**M.T. srl**

Via Casino Albini 480  
Tel. 0541/956034-957884  
Fax 0541/956341

47842 S. GIOVANNI IN M. (RN)  
e-mail: mtma@mtmarchetti.com  
http://www.mtmarchetti.com

PRODUZIONE MODULI ROTANTI



PAGINA DW0340-5-80

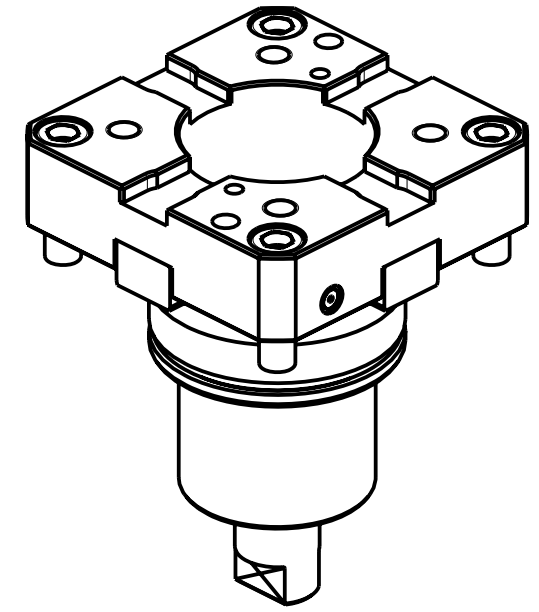
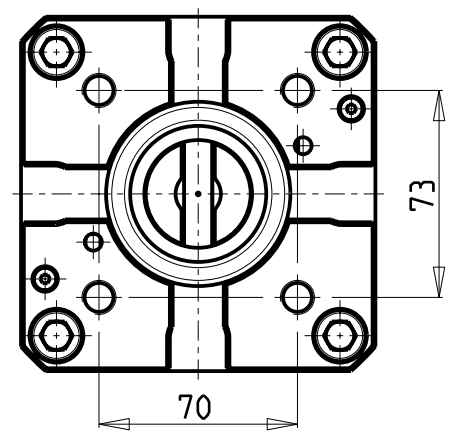
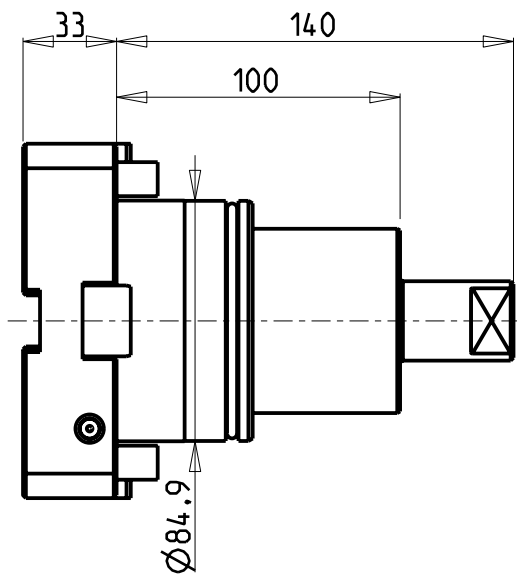
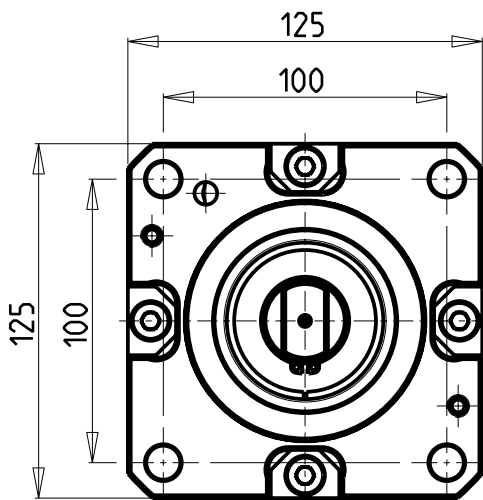

ATTENZIONE - ATTENTION - ACHTUNG  
 -PERICOLO COLLISIONE PEZZO FUORI VOLTEGGIO  
 -Danger of collision! Tooling out of interference  
 -Kollisionsgefahr! Werkzeug ausser Interferenz

Cod. MT  
 DW00370100

DOOSAN BMT 85  
 MOD: VT900M/TM - VT1100M - PUMA 600M/LM - PUMA 700M/LM - PUMA 800M/LM  
 INTERFACCIA PER MODULI BMT-65 H=33mm  
 BMT-65 tooling adapter cartridge H=33mm  
 Adapter-Patrone fuer BMT-65 werkzeuge H=33mm

**M.T. srl**  
 Via Casino Albini 480  
 Tel. 0541/956034-957884  
 Fax 0541/956341  
 47842 S. GIOVANNI IN M. (RN)  
 e-mail: mtma@mtmarchetti.com  
 http://www.mtmarchetti.com

PRODUZIONE MODULI ROTANTI  
  
 PAGINA DW0385-5-00

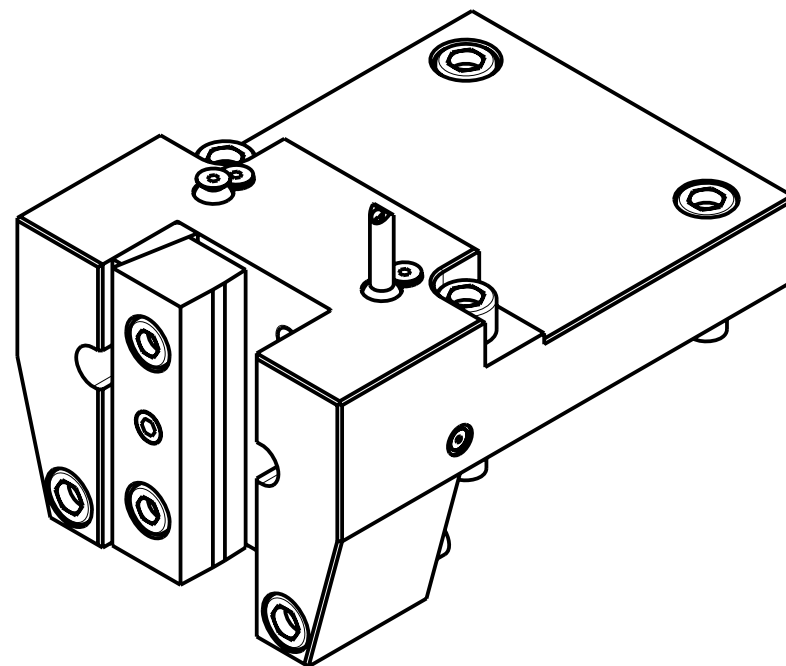
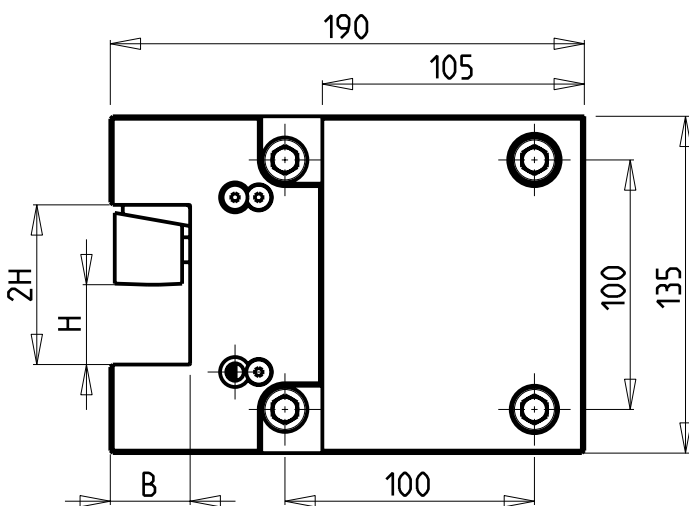
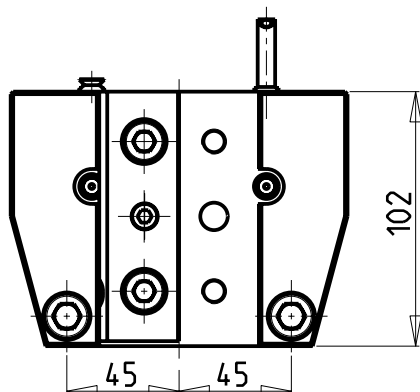
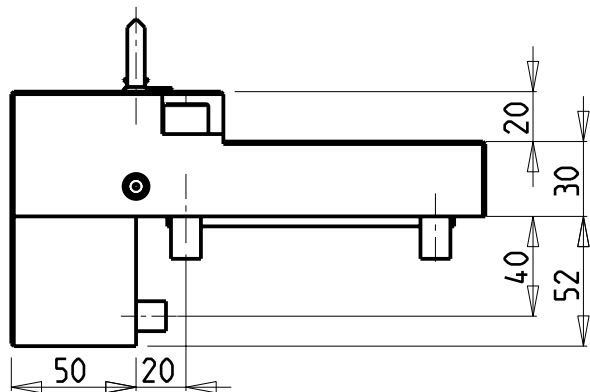

Cod. MT	N°Utensili N°Tools N°Werkzeuge	Reversibile lato mandrino/contromandrino Reversible sub/main spindle side Umkehrbare Spindel-seite/ Gegenspindel-seite	Misure Dimensions Masse	B	H
DW 00323200	1		mm	32	32
DW 00323175	1		Inch	1-1/4"	1-1/4"

DOOSAN BMT 85

MOD: VT900M/TM - VT1100M - PUMA 600M/LM - PUMA 700M/LM - PUMA 800M/LM

PORTAUTENSILE RADIALE SINGOLO

Radial single static tool

Radial Single-Werkzeughalter

**M.T. srl**

Via Casino Albini 480  
Tel. 0541/956034-957884  
Fax 0541/956341  
47842 S. GIOVANNI IN M. (RN)  
e-mail: mtma@mtmarchetti.com  
http://www.mtmarchetti.com

PRODUZIONE MODULI ROTANTI



PAGINA DW 0423-5-00

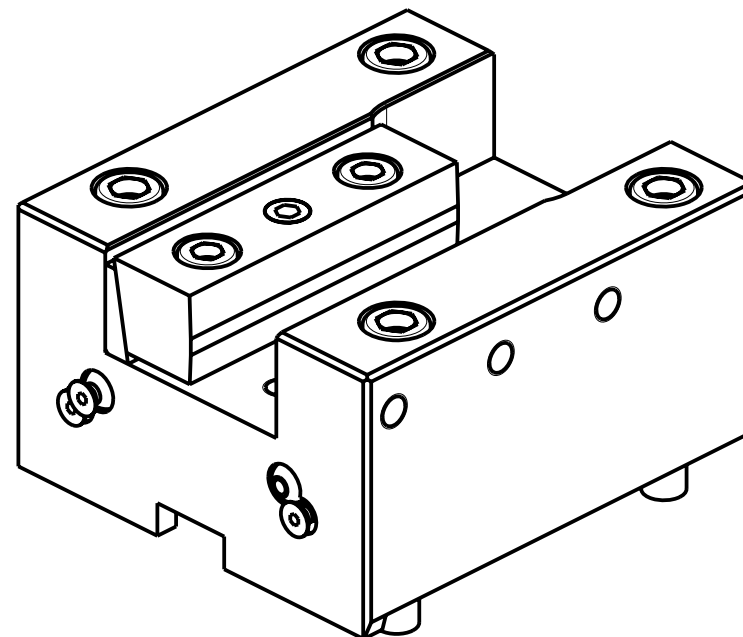
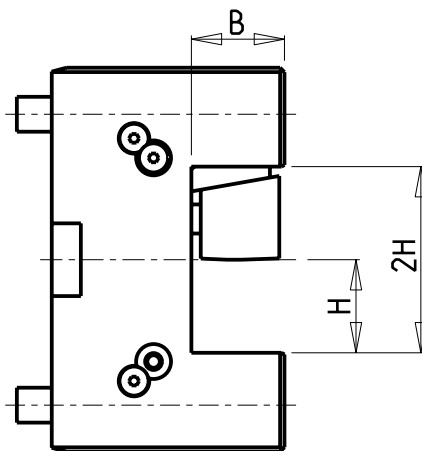
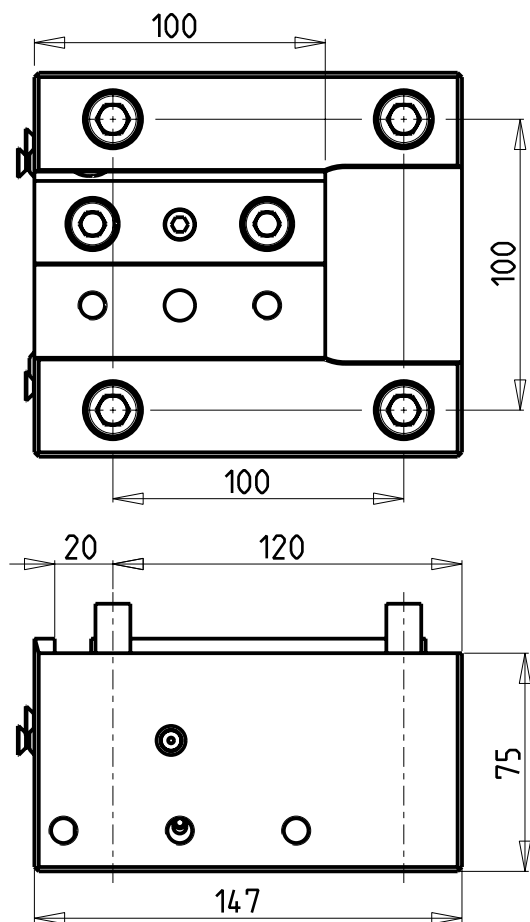

Cod. MT	N°Utensili N°Tools N°Werkzeuge	Reversibile lato mandrino/contromandrino Reversible sub/main spindle side Umkehrbare Spindelseite/ Gegenspindelseite	Misure Dimensions Masse	B	H
DW00333200	1/2	X	mm	32	32
DW00333175	1/2	X	Inch	1-1/4"	1-1/4"

DOOSAN BMT 85

MOD: VT900M/TM - VT1100M - PUMA 600M/LM - PUMA 700M/LM - PUMA 800M/LM

PORTAUTENSILE ASSIALE SINGOLO

Axial single static tool

Axial Single-Werkzeughalter

**M.T. srl**

Via Casino Albini 480  
Tel. 0541/956034-957884  
Fax 0541/956341  
47842 S. GIOVANNI IN M. (RN)  
e-mail: mtma@mtmarchetti.com  
http://www.mtmarchetti.com

PRODUZIONE MODULI ROTANTI



PAGINA DW 0552-5-00

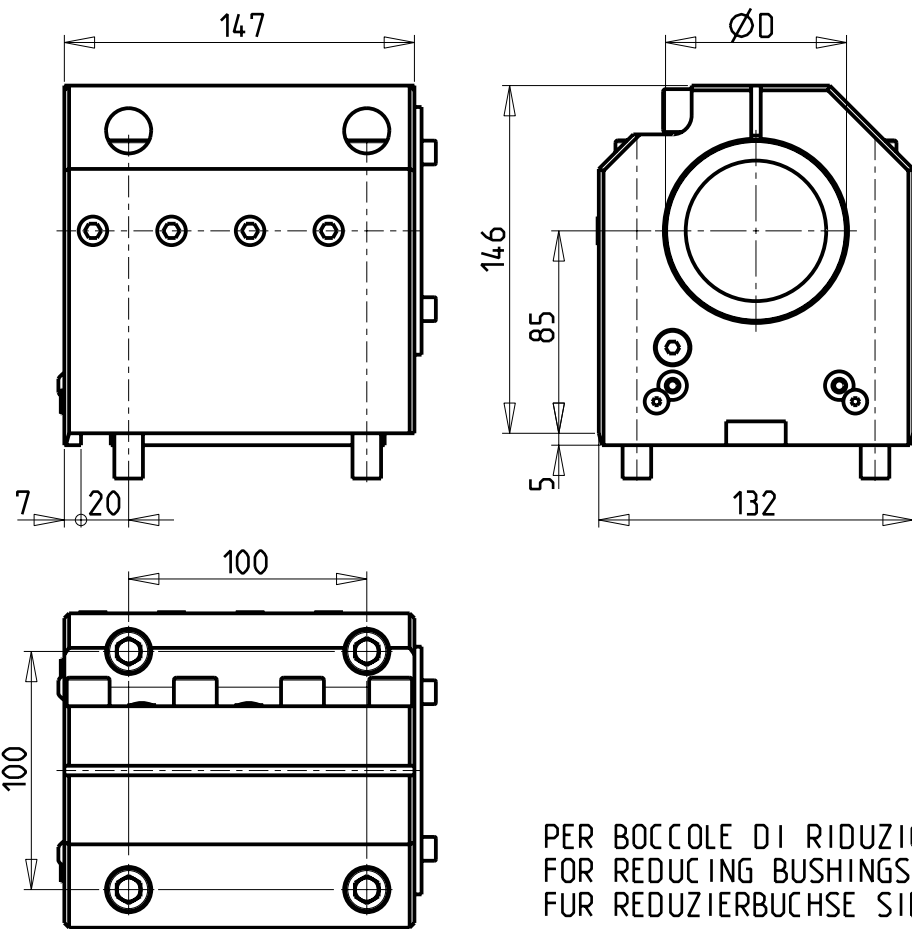

KIT ADDUZIONE INTERNA (OPZIONALE)  
 KIT FOR INTERNAL COOLANT (OPTIONAL)  
 KIT FUER INTERNE KUEHLMITTELZUFUHR (OPTIONAL)  
 Ø80 cod. KIT1002013  
 Ø3" cod. KIT1002014

SOLO GUARNIZIONE (OPZIONALE)  
 ONLY SEAL (OPTIONAL)  
 NUR DICHTUNG (OPTIONAL)  
 cod. MNL0310005

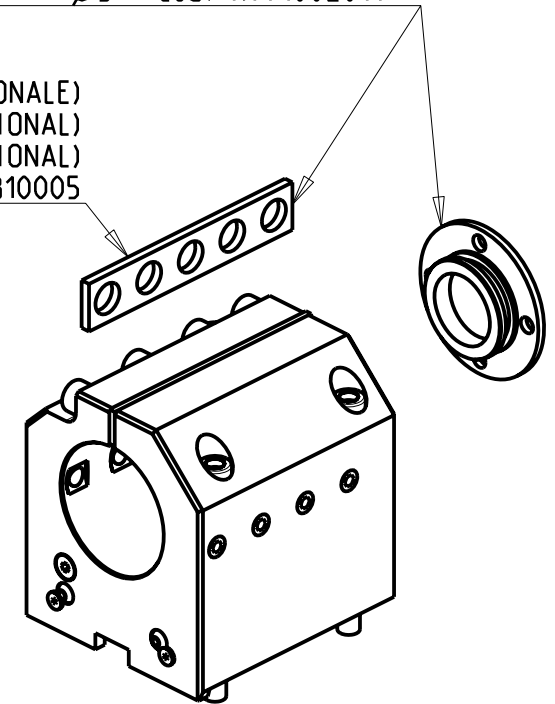

PER BOCCOLE DI RIDUZIONE VEDI PAG. TBL150-1-00  
 FOR REDUCING BUSHINGS SEE PAGE TBL150-1-00  
 FUR REDUZIERBUCHSE SIEHE SEITE TBL150-1-00

Cod. MT	N°Utensili N°Tools N°Werkzeuge	Reversibile lato mandrino/contromandrino Reversible sub/main spindle side Umkehrbare Spindelseite/ Gegenspindelseite	Lubrificazione int. opzionale Coolant through optional Innenkuehlung Optional	Lubrificazione est. Ext. coolant Aussenkuehlung	Misure Dimensions Masse	D
DW 00348000	1	X	X	X	mm	80
DW 00347620	1	X	X	X	Inch	3"

DOOSAN BMT 85

MOD: VT900M/TM - PUMA 600M/LM - PUMA 700M/LM - PUMA 800M/LM

PORTAUTENSILE ASSIALE PER BARENO Ø80mm / Ø3" H=85mm

Axial single boring bar holder Ø80mm / Ø3" H=85mm

Axial Bohrhälter Ø80mm / Ø3" H=85mm

**M.T. srl**

Via Casino Albini 480  
 Tel. 0541/956034-957884  
 Fax 0541/956341  
 47842 S. GIOVANNI IN M. (RN)  
 e-mail: mtma@mtmarchetti.com  
 http://www.mtmarchetti.com

PRODUZIONE MODULI ROTANTI



PAGINA DW 0580-5-20