

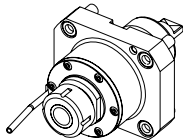
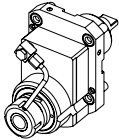
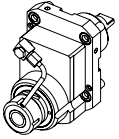
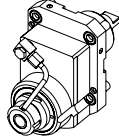
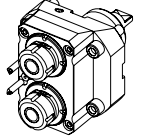
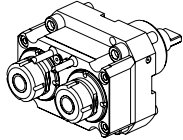
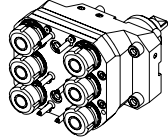
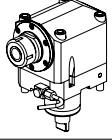
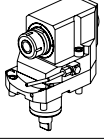
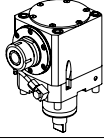
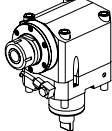
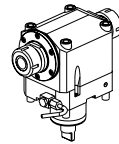

		PAGINA Page Seite
<p>MODULO MOTORIZZATO RADIALE Radial driven tool Radial angetriebenes Werkzeug</p>		GDW 010.1.00
<p>MODULO MOTORIZZATO RADIALE DISASSATO IN Z 45mm Radial driven tool re-directed in Z by 45mm Radial angetriebenes Werkzeug achsversetzt in Z um 45mm</p>		GDW 033.1.10
<p>MODULO MOTORIZZATO RADIALE RIDOTTO 1=2:1 DISASSATO IN Z 45mm Radial geared-down 1=2:1 driven tool re-directed in Z by 45mm Radial angetriebenes Werkzeug untersetzt 1=2:1 achsversetzt in Z um 45mm</p>		GDW 033.1.20
<p>MODULO MOTOR. RADIALE MOLTIPLICATO 1=1:2 DISASSATO IN Z 45mm Radial geared-up 1=1:2 driven tool re-directed in Z by 45mm Radial angetriebenes Werkzeug uebersetzt 1=1:2 achsversetzt in Z um 45mm</p>		GDW 033.1.30
<p>MODULO MOTORIZZATO RADIALE 2 USCITE IN Y Radial single side twin head driven tool in Y Radial angetriebenes Werkzeug 2 Ausgaenge in Y</p>		GDW 080.1.00
<p>MODULO MOTORIZZATO RADIALE 2 USCITE IN Z Radial single side twin head driven tool in Z Radial angetriebenes Werkzeug 2 Ausgaenge in Z</p>		GDW 090.1.00
<p>MODULO MOTORIZZATO RADIALE 6 USCITE Radial multiple 6 outlet driven tool Radial angetriebenes Mehrspindel-Werkzeug 6 Ausgaenge</p>		GDW 110.1.00
<p>MODULO MOTORIZZATO ASSIALE Axial driven tool Axial angetriebenes Werkzeug</p>		GDW 150.1.10
<p>MODULO MOTORIZZATO ASSIALE ARRETRATO Axial rear-set driven tool Axial angetriebenes Werkzeug zurueckversetzt</p>		GDW 180.1.10
<p>MODULO MOTORIZZATO ASSIALE RIDOTTO 1=2:1 Axial geared-down 1=2:1 driven tool Axial angetriebenes Werkzeug untersetzt 1=2:1</p>		GDW 190.1.10
<p>MODULO MOTORIZZATO ASSIALE MOLTIPLICATO 1=1:2 Axial geared-up 1=1:2 driven tool Axial angetriebenes Werkzeug uebersetzt 1=1:2</p>		GDW 200.1.10

		PAGINA Page Seite
<p>MODULO MOTORIZZATO ASSIALE BISPORGENTE Axial opposite face twin driven tool Axial angetriebenes Werkzeug halb vorspringend</p>		GDW 240.1.10
<p>MODULO MOTORIZZATO ASSIALE BISPORGENTE MOLTIPLICATO 1=1:2 Axial geared-up 1=1:2 opposite face twin driven tool Axial angetriebenes Werkzeug halb vorspringend uebersetzt 1=1:2</p>		GDW 250.1.10
<p>MODULO MOTORIZZATO ASSIALE 2 USCITE IN Y Axial single side twin head driven tool in Y Axial angetriebenes Werkzeug 2 Ausgaenge in Y</p>		GDW 260.1.10
<p>MODULO MOTORIZZATO ASSIALE 4/8 USCITE Axial multiple 4/8 outlet driven tool Axial angetriebenes Mehrspindel-Werkzeug 4/8 Ausgaenge</p>		GDW 270.1.00
<p>MODULO MOTORIZZATO ORIENTABILE 0-90° 0-90° adjustable angle driven tool Angetriebenes Werkzeug schwenkbar 0-90°</p>		GDW 330.1.00
<p>MODULO MOTORIZZATO ORIENTABILE +/-90° +/-90° adjustable angle driven tool Angetriebenes Werkzeug schwenkbar +/-90°</p>		GDW 335.1.00
<p>MODULO MOTORIZZATO ORIENTABILE +/-90° MOLTIPLICATO 1=1:2 +/-90° adjustable angle driven tool geared-up 1=1:2 Angetriebenes Werkzeug schwenkbar +/-90° uebersetzt 1=1:2</p>		GDW 336.1.00
<p>MODULO MOTORIZZATO PORTACREATORE Driven gear hobber Angetriebenes Zahnradwaelzfraes-Werkzeug</p>		GDW 340.1.00
<p>MODULO MOTORIZZATO PORTACREATORE MAGGIORATO Reinforced driven gear hobber Angetriebenes Zahnradwaelzfraes-Werkzeug vergroessert</p>		GDW 340.1.60
<p>MODULO MOTORIZZATO PER VITI SENZA FINE Driven tool for worm screws Angetriebenes werkzeug fuer schrauben ohne ende</p>		GDW 359.1.00

		PAGINA Page Seite
PORTAUTENSILE RADIALE SINGOLO Radial single static tool Radial Single-Werkzeughalter		GDW 423.1.00
PORTAUTENSILE RADIALE SINGOLO ARRETRATO Radial rear-set single static tool Radial Single-Werkzeughalter zurueckversetzt		GDW 433.1.00
PORTAUTENSILE RADIALE SOVRAPPOSTO Radial single side twin static tool Radial Werkzeughalter ueberlagert		GDW 442.1.00
PORTAUTENSILE RADIALE DOPPIO Radial double static tool Radial Doppel-Werkzeughalter		GDW 453.1.00
PORTAUTENSILE RADIALE DOPPIO SOVRAPPOSTO Radial double side twin static tool Radial Doppel-Werkzeughalter ueberlagert		GDW 463.1.00
PORTAUTENSILE PER LAMA DOPPIO Radial double blade holder Radial Doppel-Abstechhalter		GDW 520.1.00
PORTAUTENSILE PER LAMA DOPPIO E SOVRAPPOSTO Radial double twin-side blade holder Radial Doppel-Abstechhalter ueberlagert		GDW 525.1.00
PORTAUTENSILE ASSIALE SINGOLO Axial single static tool Axial Single-Werkzeughalter		GDW 552.1.00
PORTAUTENSILE ASSIALE PER BARENO Ø50mm / Ø2" H=80mm Axial single boring bar holder Ø50mm / Ø2" H=80mm Axial Bohrhalter Ø50mm / Ø2" H=80mm		GDW 610.1.20
PORTAUTENSILE ASSIALE PER BARENO Ø40mm / Ø1 1/2" H=80mm Axial single boring bar holder Ø40mm / Ø1 1/2" H=80mm Axial Bohrhalter Ø40mm / Ø1 1/2" H=80mm		GDW 630.1.20
PORTAUTENSILE ASSIALE PROLUNGATO PER BARENO Ø40mm H=80mm Axial single extended boring bar holder Ø40mm H=80mm Axial Bohrhalter verlaengert Ø40mm H=80mm		GDW 760.1.20
PORTAUTENSILE ASSIALE PER BARENO 2+2 POSIZIONI Ø32mm / Ø1 1/4" Axial 2+2 position upright boring bar holder Ø32mm / Ø1 1/4" Axial Bohrhalter 2+2 Positionen Ø32mm / Ø1 1/4"		GDW 872.1.00

		PAGINA Page Seite
<p>PORTAUTENSILE ASSIALE PER BARENO 3+3 POSIZ. SOVRAPP. Ø 25mm / Ø 1" Axial 3+3 position upright boring bar holder Ø25mm / Ø1" Axial Bohrhälter 3+3 Positionen ueberlagert Ø25mm / Ø1"</p>		GDW 894.1.00
<p>PORTAUTENS. ASSIALE ARRETRATO PER BARENO 3 POS. SOVRAPP. Ø 25mm / Ø 1" Axial 3 position upright rear set boring bar holder Ø25mm / Ø1" Axial Bohrhälter 3 Positionen zurueckversetzt ueberlagert Ø25mm / Ø1"</p>		GDW 904.1.00
<p>PORTAUTENSILE ASSIALE PER BARENO 3+3 POSIZIONI Ø 32mm / Ø 1 1/4" Axial 3+3 position boring bar holder Ø32mm / Ø1 1/4" Axial Bohrhälter 3+3 Positionen Ø32mm / Ø1 1/4"</p>		GDW 912.1.00
<p>PORTAUTENSILE ASSIALE PER BARENO 4+4 POSIZIONI Ø 25mm / Ø 1" Axial 4+4 position boring bar holder Ø25mm / Ø1" Axial Bohrhälter 4+4 Positionen Ø25mm / Ø1"</p>		GDW 922.1.00
<p>PORTAUTENSILE ASSIALE PER BARENO 8 POSIZIONI Ø 20mm / Ø 3/4" Axial 8 position boring bar holder Ø20mm / Ø3/4" Axial Bohrhälter 8 Positionen Ø20mm / Ø3/4"</p>		GDW 933.1.00
<p>CONTROPUNTA PER CONTROMANDRINO Tailstock for subspindle Gegenspitz fuer Gegenspindel</p>		GDW 950.1.00

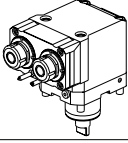
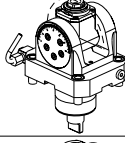
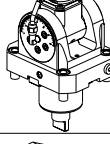
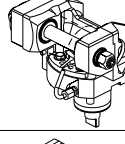
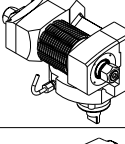
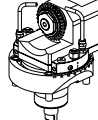
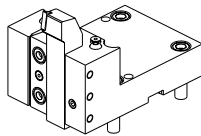
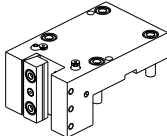
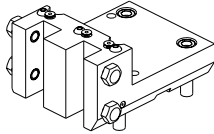
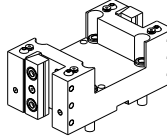
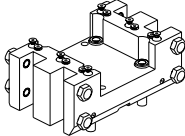
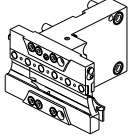
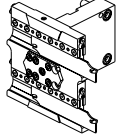
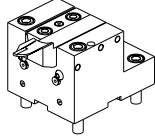
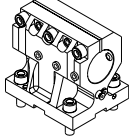
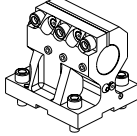
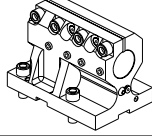
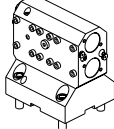
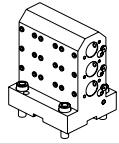
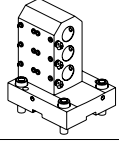
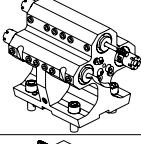
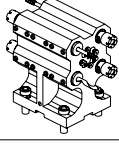
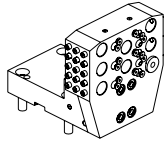
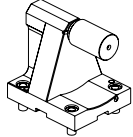
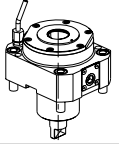
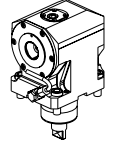
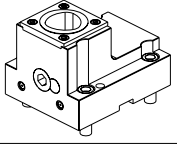
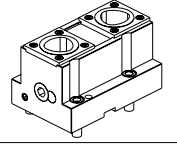
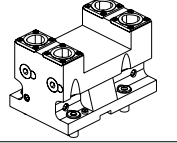
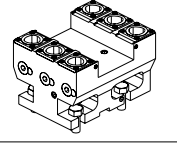
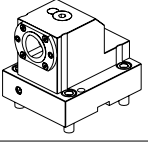
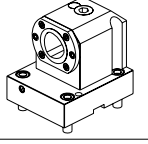
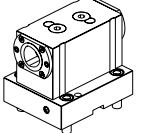
		PAGINA Page Seite
MODULO MOTORIZZATO RADIALE COROMANT CAPTO® Radial driven tool COROMANT CAPTO® Radial angetriebenes Werkzeug COROMANT CAPTO®		GDW 010.A.40
MODULO MOTORIZZATO ASSIALE COROMANT CAPTO® Axial driven tool COROMANT CAPTO® Axial angetriebenes Werkzeug COROMANT CAPTO®		GDW 150.A.40
PORTAUTENSILE RADIALE SINGOLO COROMANT CAPTO® Radial single static tool COROMANT CAPTO® Radial Single-Werkzeughalter COROMANT CAPTO®		GDW 420.A.40
PORTAUTENSILE RADIALE DOPPIO COROMANT CAPTO® Radial double static tool COROMANT CAPTO® Radial doppel-Werkzeughalter COROMANT CAPTO®		GDW 450.A.40
PORTAUTENSILE RADIALE DOPPIO SOVRAPP. 2+2 POS. COROMANT CAPTO® Radial double 2+2 upright position static tool COROMANT CAPTO® Radial Doppel-Werkzeughalter 2+2 Positionen ueberlagert COROMANT CAPTO®		GDW 460.A.30
PORTAUTENSILE RADIALE DOPPIO SOVRAPP. 3+3 POS. COROMANT CAPTO® Radial double 3+3 upright position static tool COROMANT CAPTO® Radial Doppel-Werkzeughalter 3+3 Positionen ueberlagert COROMANT CAPTO®		GDW 465.A.30
PORTAUTENSILE ASSIALE SINGOLO COROMANT CAPTO® Axial single static tool COROMANT CAPTO® Axial Single-Werkzeughalter COROMANT CAPTO®		GDW 550.A.40
PORTAUTENSILE ASSIALE SINGOLO ARRETRATO COROMANT CAPTO® Axial single rear set static tool COROMANT CAPTO® Axial Single-Werkzeughalter zurueckversetzt COROMANT CAPTO®		GDW 555.A.40
PORTAUTENSILE ASSIALE BISPORGENTE COROMANT CAPTO® Axial opposite face twin static tool COROMANT CAPTO® Axial Werkzeughalter halb vorspringend mit COROMANT CAPTO®		GDW 570.A.40

		PAGINA Page Seite
<p>MODULO MOTORIZZATO RADIALE Radial driven tool Radial angetriebenes Werkzeug</p>		GDW 010.2.00
<p>MODULO MOTORIZZATO RADIALE 2 USCITE IN Y Radial single side twin head driven tool in Y Radial angetriebenes Werkzeug 2 Ausgaenge in Y</p>		GDW 080.2.00
<p>MODULO MOTORIZZATO SPECIALE RADIALE DISASSATO IN Z 376mm Radial special driven tool re-directed in Z by 376mm Radial spezial angetriebenes Werkzeug achsversetzt in Z um 376mm</p>		GDW 125.2.10
<p>MODULO MOTORIZZATO SPECIALE RADIALE IN Y Radial special driven tool in Y Radial spezial angetriebenes Werkzeug in Y</p>		GDW 130.2.00
<p>MODULO MOTORIZZATO ASSIALE Axial driven tool Axial angetriebenes Werkzeug</p>		GDW 150.2.10
<p>MODULO MOTORIZZATO ORIENTABILE 0-90° 0-90° adjustable angle driven tool Angetriebenes Werkzeug schwenkbar 0-90°</p>		GDW 330.2.00
<p>MODULO MOTORIZZATO ORIENTABILE ±90° ±90° adjustable angle driven tool Angetriebenes Werkzeug schwenkbar ±90°</p>		GDW 335.2.00
<p>MODULO MOTORIZZATO PORTACREATORE Driven gear hobber Angetriebenes Zahnradwaelzfraes-Werkzeug</p>		GDW 340.2.00
<p>MODULO MOTORIZZATO PORTACREATORE RADIALE Radial driven gear hobber Radial angetriebenes Zahnradwaelzfraes-Werkzeug</p>		GDW 340.2.30
<p>PORTAUTENSILE PER LAMA DOPPIO Radial double blade holder Radial Doppel-Abstechhalter</p>		GDW 520.2.00

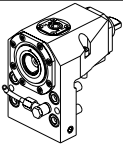
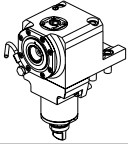
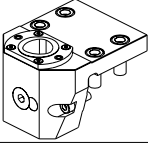
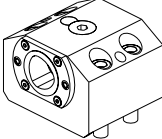
		PAGINA Page Seite
<p>MODULO MOTORIZZATO RADIALE COROMANT CAPTO® Radial driven tool COROMANT CAPTO® Radial angetriebenes Werkzeug COROMANT CAPTO®</p>		GDW 010.B.40
<p>MODULO MOTORIZZATO ASSIALE COROMANT CAPTO® Axial driven tool COROMANT CAPTO® Axial angetriebenes Werkzeug COROMANT CAPTO®</p>		GDW 150.B.40
<p>PORTAUTENSILE RADIALE SINGOLO ARRETRATO COROMANT CAPTO® Radial rear-set single static tool COROMANT CAPTO® Radial Single-Werkzeughalter zurueckversetzt COROMANT CAPTO®</p>		GDW 430.B.40
<p>PORTAUTENSILE ASSIALE SINGOLO COROMANT CAPTO® Axial single static tool COROMANT CAPTO® Axial Single-Werkzeughalter COROMANT CAPTO®</p>		GDW 550.B.40

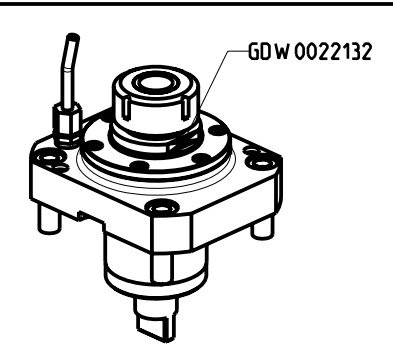
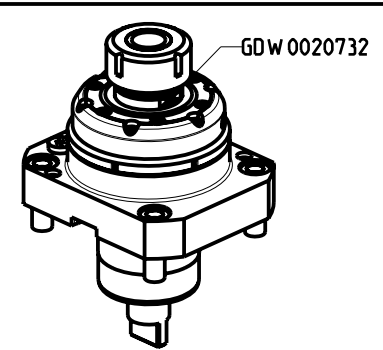
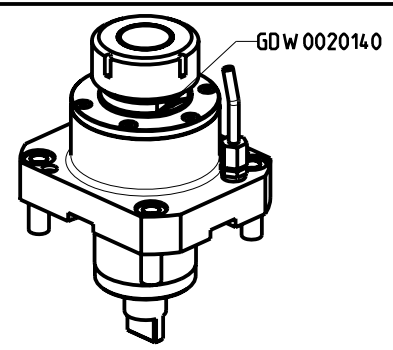
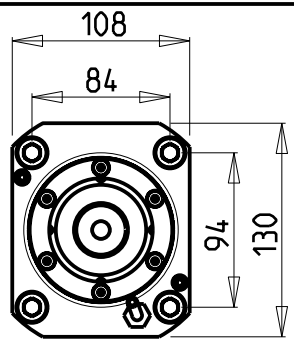
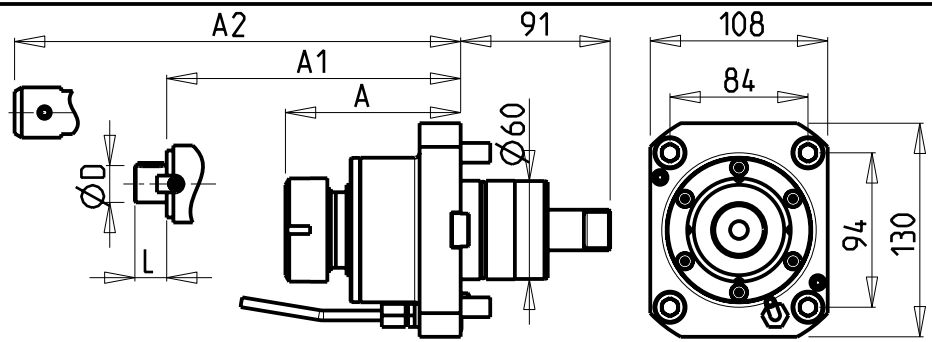

Cod. MT	Mandrino Spindle Spindel	I	RPM	Coppia Max Max Torque Max Drehmoment	Lubrificazione int. Coolant through Innenkuehlung	Lubrificazione est. Ext. coolant Aussenkuehlung	A	A1	A2	D	L	CHIAVI NON INCLUSE Keys not included Schlüssel nicht einbegriffen	
GDW 0020532	ER32	1:1	6000	70Nm		X	104.16	-	-	-	-	CHUB46	CHSTER32
GDW 0020140	ER40	1:1	6000	70Nm		X	106.66	-	-	-	-	CHUB46	CHSTER40
GDW 0021532	ER32	1:1	6000	70Nm	P=30bar	X	104.16	-	-	-	-	CHUB46	CHSTER32
GDW 0021140	ER40	1:1	6000	70Nm	P=30bar	X	106.66	-	-	-	-	CHUB46	CHSTER40
GDW 0020632	ER32	1:1	6000	70Nm		X	144.16	-	-	-	-	CHUB46	CHSTER32
GDW 0021632	ER32	1:1	6000	70Nm	P=30bar	X	144.16	-	-	-	-	CHUB46	CHSTER32
GDW 0020732	ER32	1:1	6000	70Nm	P=30bar	X	107.66	-	-	-	-	CHUB36	CHSTER32
GDW 0021617	Ø16x17	1:1	6000	70Nm		X	-	116	-	16	17	CHUB46	CH_VTCROCE_M08 •
GDW 0022219	Ø22x19	1:1	6000	70Nm		X	-	106	-	22	19	CHUB46	CH_VTCROCE_M10 •
GDW 0020122	Ø22x19	1:1	6000	70Nm	P=30bar	X	-	106	-	22	19	CHUB46	CH_VTCROCE_M10 •
GDW 0022721	Ø27x21	1:1	6000	70Nm		X	-	81.5	-	27	21	CHUB46	CH_VTCROCE_M12 •
GDW 0022519	Ø1"x19	1:1	6000	70Nm		X	-	81.5	-	1"	21	CHUB46	CH_VTCROCE_M12 •
GDW 0020525	Ø1"x19	1:1	6000	70Nm	P=30bar	X	-	84.5	-	1"	21	CHUB46	CH_VTCROCE_M12 •
GDW 0022132	ER32 CORTO-SHORT-KURZ	1:1	6000	70Nm		X	75.76	-	-	-	-	CHUB46	CHSTER32
GDW 0022140	ER40 CORTO-SHORT-KURZ	1:1	6000	70Nm		X	89.66	-	-	-	-	CHUB46	CHSTER40
GDW 0020120	WELDON 20	1:1	6000	70Nm		X	-	-	99.5	-	-		
GDW 0020125	WELDON 25	1:1	6000	70Nm		X	-	-	109	-	-		
GDW 0020132	WELDON 32	1:1	6000	70Nm		X	-	-	125.5	-	-		
GDW 0020220	WELDON 20	1:1	6000	70Nm	P=30bar	X	-	-	99.5	-	-		
GDW 0020425	WELDON 25	1:1	6000	70Nm	P=30bar	X	-	-	109	-	-		

- Chiave inclusa
- Key included
- Schlüssel einbegriffen

GOODWAY
 MOD: GS2600/2800
 MODULO MOTORIZZATO RADIALE
 Radial driven tool
 Radial angetriebenes Werkzeug

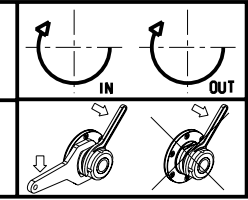

M.T. srl
 Via Casino Albini 480
 Tel. 0541/956034-957884
 Fax 0541/956341
 47842 S. GIOVANNI IN M. (RN)
 e-mail: mtma@mtmarchetti.com
 http://www.mtmarchetti.com

PRODUZIONE MODULI ROTANTI

PAGINA GDW 010-1-00

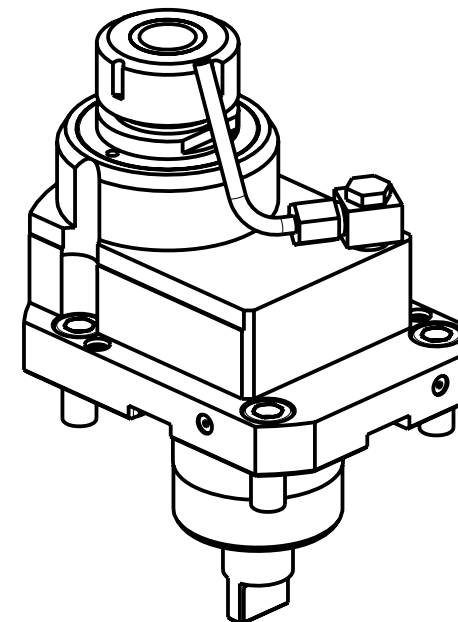
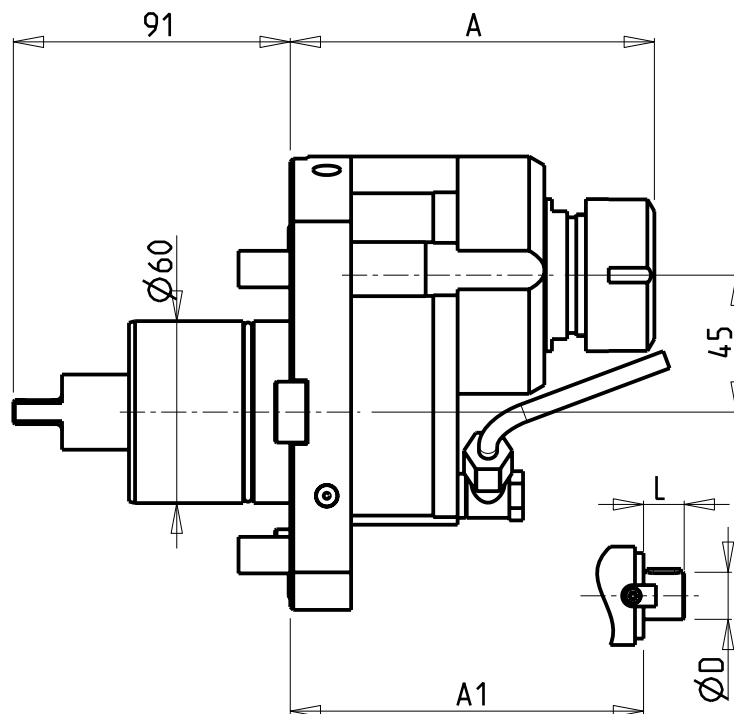
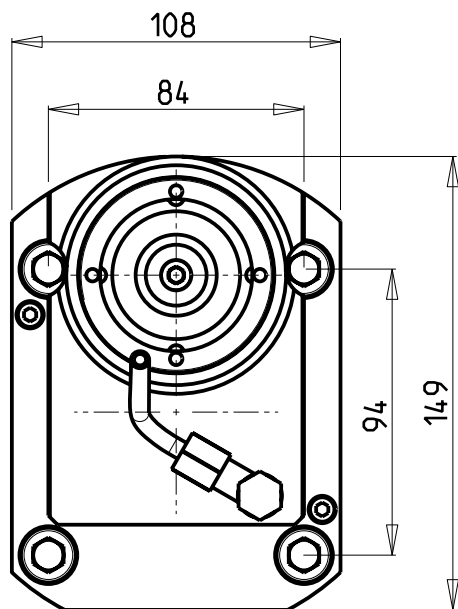

Cod. MT	Mandrino Spindle Spindel	I	RPM	Coppia Max Max Torque Max Drehmoment	Reversibile lato mandrino/contromandrino Reversible sub/main spindle side Umkehrbare Spindel-seite/ Gegenspindel-seite	Lubr. esterna Ext. coolant Aussenkuehlung	A	A1	D	L	CHIAVI NON INCLUSE Keys not included Schluessel nicht einbegriffen	
GDW 0060032	ER32	1:1	6000	70Nm	X	X	119.66	-	-	-	CHUB42	CHSTER32
GDW 0061116	Ø16x17	1:1	6000	70Nm	X	X	-	98	16	17	CHUB42	CH_VTCROCE_M08 •
GDW 0061122	Ø22x19	1:1	6000	70Nm	X	X	-	98	22	19	CHUB42	CH_VTCROCE_M10 •
GDW 0061127	Ø27x21	1:1	6000	70Nm	X	X	-	98	27	21	CHUB42	CH_VTCROCE_M12 •
GDW 0061119	Ø3/4"x3/4"	1:1	6000	70Nm	X	X	-	98	3/4"	3/4"	CHUB42	CH_VTCROCE_M08 •
GDW 0062225	Ø1"x19	1:1	6000	70Nm	X	X	-	98	1"	19	CHUB42	CH_VTCROCE_M12 •

- Chiave inclusa
- Key included
- Schluessel einbegriffen

GOODWAY
MOD: GS2600/2800

MODULO MOTORIZZATO RADIALE DISASSATO IN Z 45mm
Radial driven tool re-directed in Z by 45mm
Radial angetriebenes Werkzeug achsversetzt in Z um 45mm

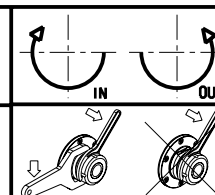

M.T. srl
Via Casino Albini 480
Tel. 0541/956034-957884
Fax 0541/956341
47842 S. GIOVANNI IN M. (RN)
e-mail: mtma@mtmarchetti.com
http://www.mtmarchetti.com

PRODUZIONE MODULI ROTANTI



PAGINA GDW033-1-10

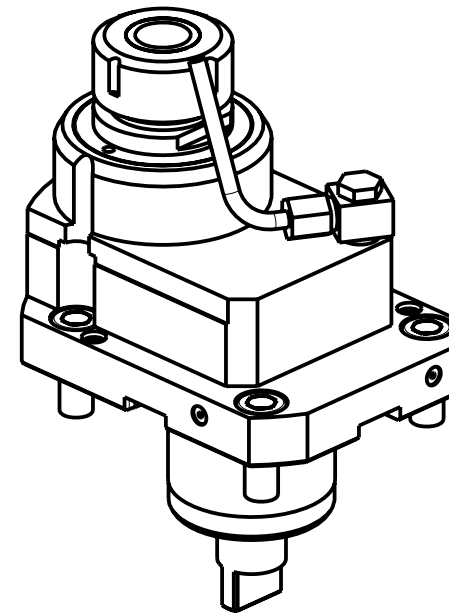
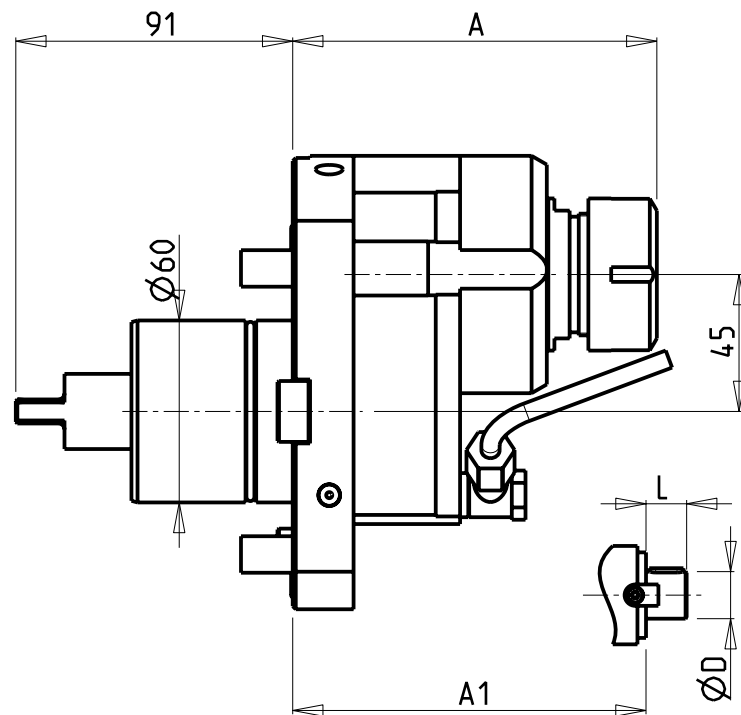
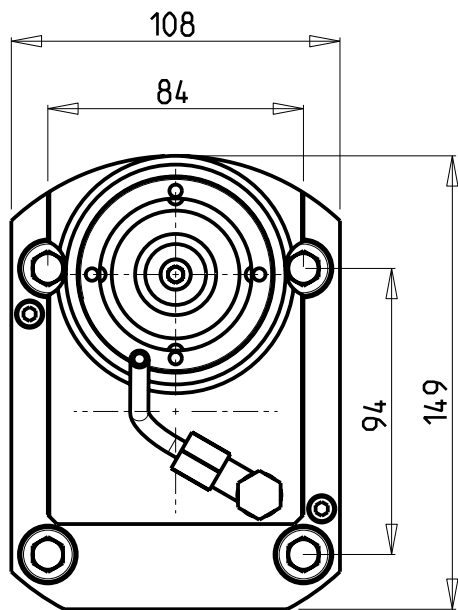

- Chiave inclusa
- Key included
- Schluessel inbegriffen

Cod. MT	Mandrino Spindle Spindel	I	RPM	Coppia Max Max Torque Max Drehmoment	Reversibile lato mandrino/contromandrino Reversible sub/main spindle side Umkehrbare Spindel-seite/ Gegenspindel-seite	Lubr.esterna Ext. coolant Aussenkuehlung	A	A1	D	L	CHIAVI NON INCLUSE Keys not included Schluessel nicht einbegriffen	
GDW 0062132	ER32	2:1	3000	80Nm	X	X	119.66	-	-	-	CHUB36	CHSTER32
GDW 0062122	Ø22x19	2:1	3000	80Nm	X	X	-	98	22	19	CHUB36	CH_VTCROCE_M10
GDW 0062127	Ø27x21	2:1	3000	80Nm	X	X	-	98	27	21	CHUB36	CH_VTCROCE_M12
GDW 0062119	Ø3/4"x3/4"	2:1	3000	80Nm	X	X	-	98	3/4"	3/4"	CHUB36	CH_VTCROCE_M08
GDW 0062125	Ø1"x19	2:1	3000	80Nm	X	X	-	98	1"	19	CHUB36	CH_VTCROCE_M12

GOODWAY
 MOD: GS2600/2800
 MODULO MOTORIZZATO RADIALE RIDOTTO I=2:1 DISASSATO IN Z 45mm
 Radial geared-down I=2:1 driven tool re-directed in Z by 45mm
 Radial angetriebenes Werkzeug untersetzt I=2:1 achsversetzt in Z um 45mm

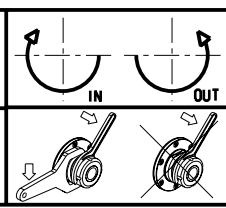

M.T. srl
 Via Casino Albini 480
 Tel. 0541/956034-957884
 Fax 0541/956341
 47842 S. GIOVANNI IN M. (RN)
 e-mail: mtma@mtmarchetti.com
 http://www.mtmarchetti.com

PRODUZIONE MODULI ROTANTI

PAGINA GDW 033-1-20

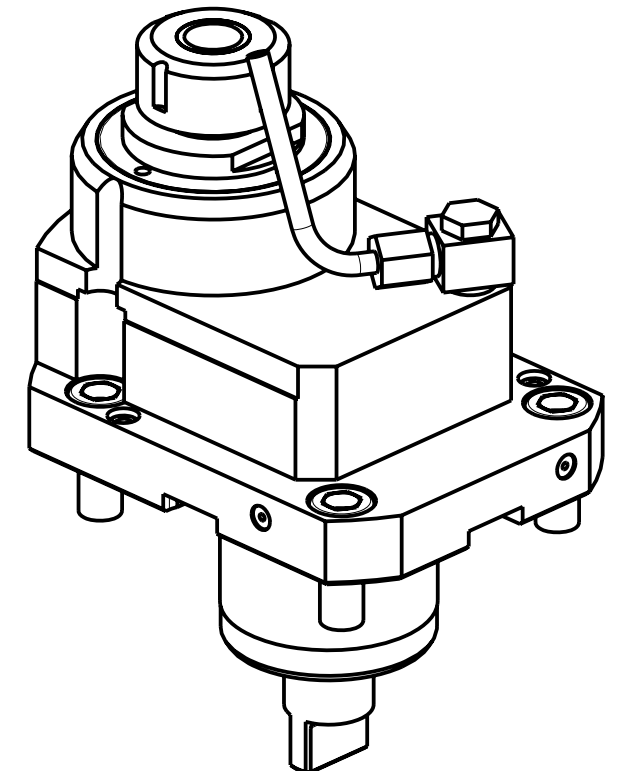
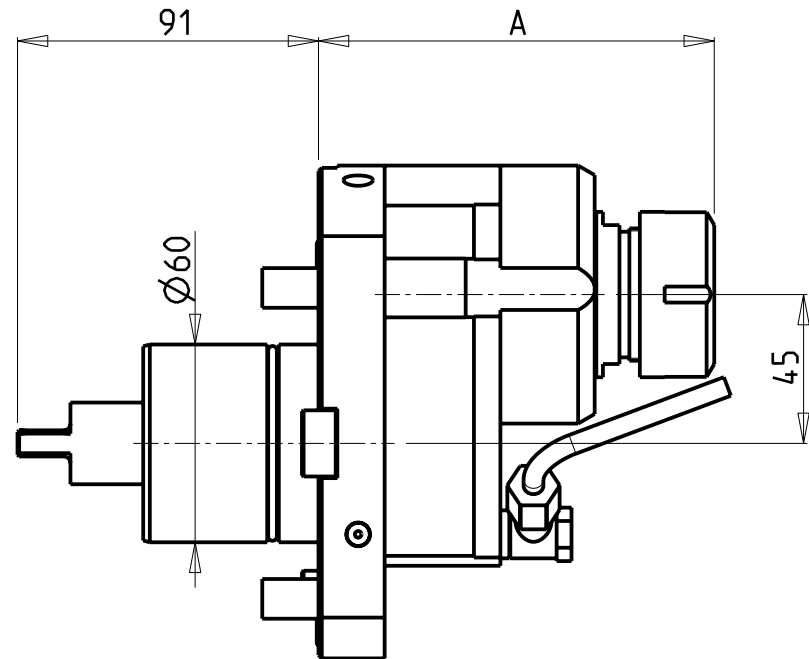
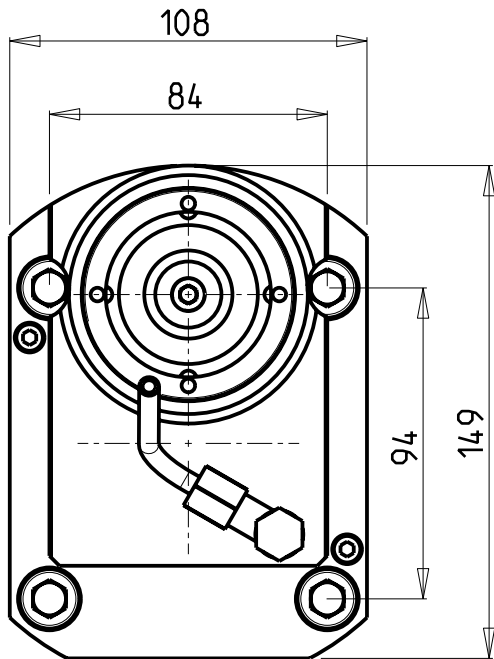

Cod. MT	Mandrino Spindle Spindel	i	RPM MAX	Coppia Max Max Torque Max Drehmoment	Reversibile lato mandrino/contromandrino Reversible sub/main spindle side Umkehrbare Spindel-seite/ Gegenspindel-seite	Lubrificazione int. Coolant through Innenkuehlung	Lubrificazione est. Ext. coolant Aussenkuehlung	A	CHIAVI NON INCLUSE Keys not included Schluessel nicht einbegriffen	
GDW 0061225	ER25	1:2	12000	40Nm	X		X	115.16	CHUB42	CHSTER25
GDW 0062425	ER25	1:2	10000	40Nm	X	P=70bar	X	126.16	CHUB42	CHSTER25

GOODWAY
MOD: GS2600/2800

MODULO MOTORIZZATO RADIALE MOLTIPLICATO I=1:2 DISASSATO IN Z 45mm
Radial geared-up I=1:2 driven tool re-directed in Z by 45mm
Radial angetriebenes Werkzeug uebersetzt I=1:2 achsversetzt in Z um 45mm

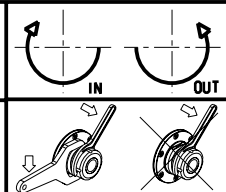

M.T. srl
Via Casino Albini 480
Tel. 0541/956034-957884
Fax 0541/956341
47842 S. GIOVANNI IN M. (RN)
e-mail: mtma@mtmarchetti.com
<http://www.mtmarchetti.com>

PRODUZIONE MODULI ROTANTI

PAGINA GDW 033-1-30

ATTENZIONE - ATTENTION - ACHTUNG

- Per lo smontaggio degli utensili utilizzare sempre la chiave di contrasto come indicato nel manuale d'uso.
- For disassembly of the tools use always the contrast key as mentioned in the user instructions.
- Fuer das Abmontieren der Werkzeuge immer den Gegenschlüssel benutzen wie in der Bedienungsanleitung erwäehnt.

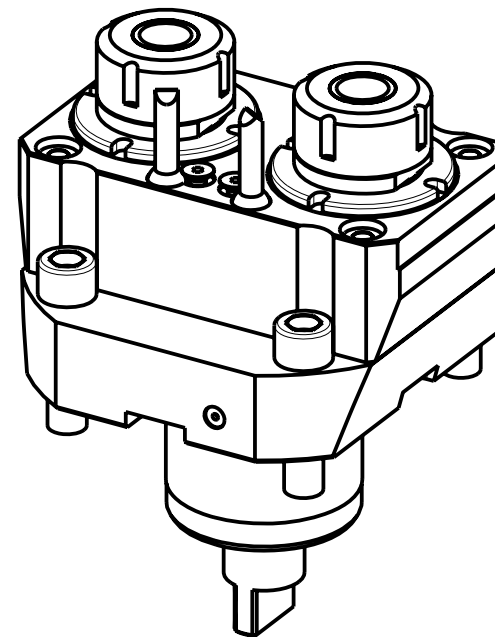
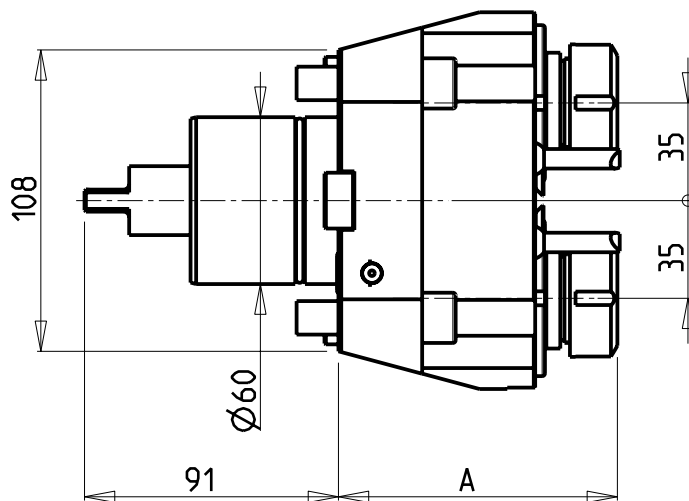
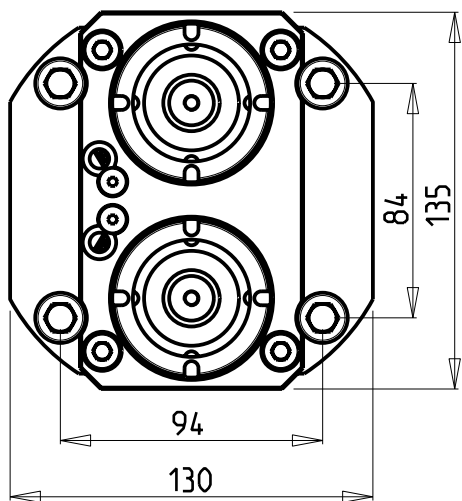

GDW 0141325

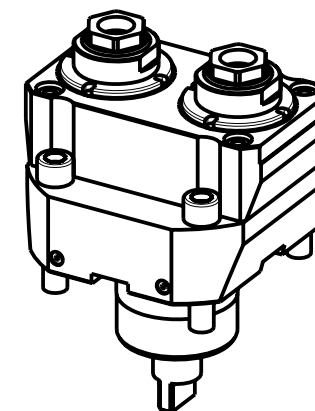

Cod. MT	Mandrino Spindle Spindel	I	RPM	Coppia Max Max Torque Max Drehmoment	Lubrificazione int. Coolant through Innenkuehlung	Lubrificazione est. Ext. coolant Aussenkuehlung	A	CHIAVI NON INCLUSE Keys not included Schlüssel nicht einbegriffen	
								CHUB36	CHSTER25
GDW 0140225	ER25	1:1	6000	40Nm		X	99.96	CHUB36	CHSTER25
GDW 0141225	ER25	1:1	6000	40Nm	P=70bar	X	115.2	CHUB36	CHSTER25
GDW 0141325	ER A 25	1:1	6000	40Nm	P=70bar	X	108.53	CHUB38	CHUB27

GOODWAY

MOD: GS2600/2800

MODULO MOTORIZZATO RADIALE 2 USCITE IN Y
Radial single side twin head driven tool in Y
Radial angetriebenes Werkzeug 2 Ausgaenge in Y

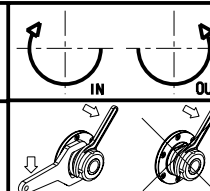

M.T. srl

Via Casino Albini 480
Tel. 0541/956034-957884
Fax 0541/956341

47842 S. GIOVANNI IN M. (RN)
e-mail: mtma@mtmarchetti.com
http://www.mtmarchetti.com

PRODUZIONE MODULI ROTANTI



PAGINA GDW 080-1-00

ATTENZIONE - ATTENTION - ACHTUNG

- Per lo smontaggio degli utensili utilizzare sempre la chiave di contrasto come indicato nel manuale d'uso.
- For disassembly of the tools use always the contrast key as mentioned in the user instructions.
- Fuer das Abmontieren der Werkzeuge immer den Gegenschlüssel benutzen wie in der Bedienungsanleitung erwäehnt.

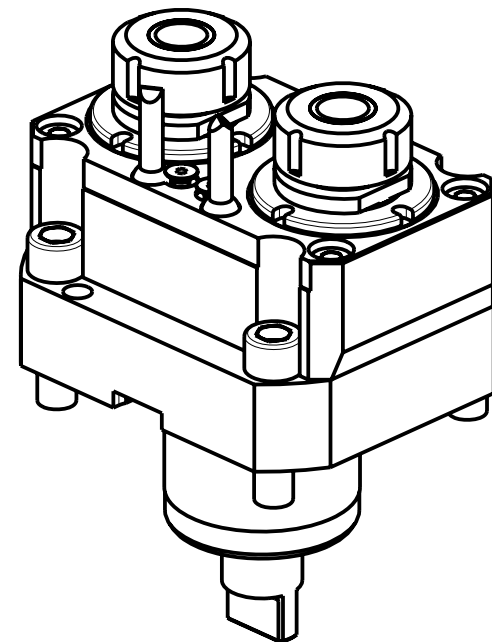
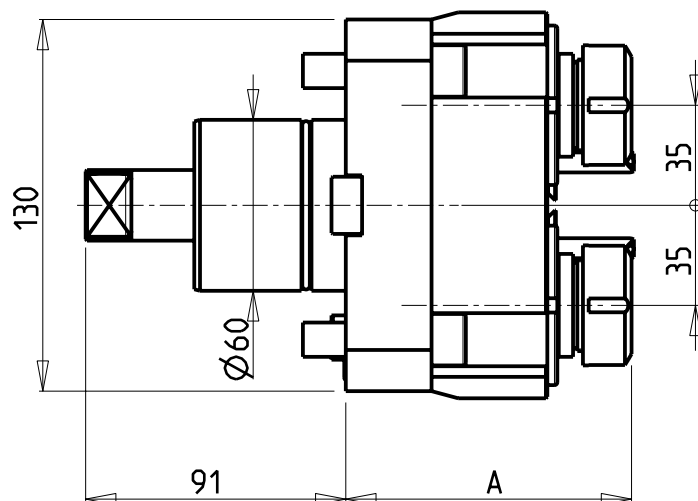
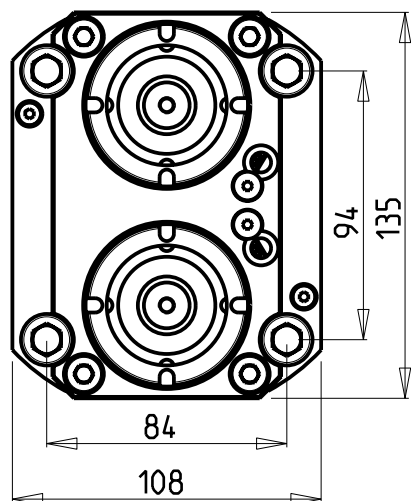

GDW 0151325

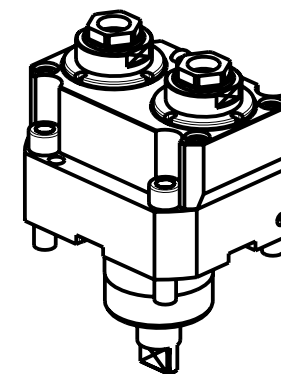

Cod. MT	Mandrino Spindle Spindel	I	RPM	Coppia Max Max Torque Max Drehmoment	Lubrificazione int. Coolant through Innenkuehlung	Lubrificazione est. Ext. coolant Aussekuehlung	A	CHIAVI NON INCLUSE Keys not included Schlüssel nicht einbegriffen	
								CHUB36	CHSTER25
GDW 0150225	ER25	1:1	6000	40Nm		X	99.96	CHUB36	CHSTER25
GDW 0151225	ER25	1:1	6000	40Nm	P=70bar	X	115.2	CHUB36	CHSTER25
GDW 0151325	ER A 25	1:1	6000	40Nm	P=70bar	X	108.53	CHUB38	CHUB27

GOODWAY
MOD: GS2600/2800

MODULO MOTORIZZATO RADIALE 2 USCITE IN Z
Radial single side twin head driven tool in Z
Radial angetriebenes Werkzeug 2 Ausgaenge in Z

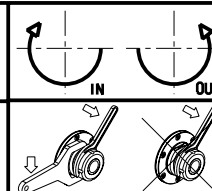

M.T. srl

Via Casino Albini 480
Tel. 0541/956034-957884
Fax 0541/956341

47842 S. GIOVANNI IN M. (RN)
e-mail: mtma@mtmarchetti.com
http://www.mtmarchetti.com

PRODUZIONE MODULI ROTANTI



PAGINA GDW 090-1-00

ATTENZIONE - ATTENTION - ACHTUNG

- Per lo smontaggio degli utensili utilizzare sempre la chiave di contrasto come indicato nel manuale d'uso.
- For disassembly of the tools use always the contrast key as mentioned in the user instructions.
- Fuer das Abmontieren der Werkzeuge immer den Gegenschlüssel benutzen wie in der Bedienungsanleitung erwahnt.

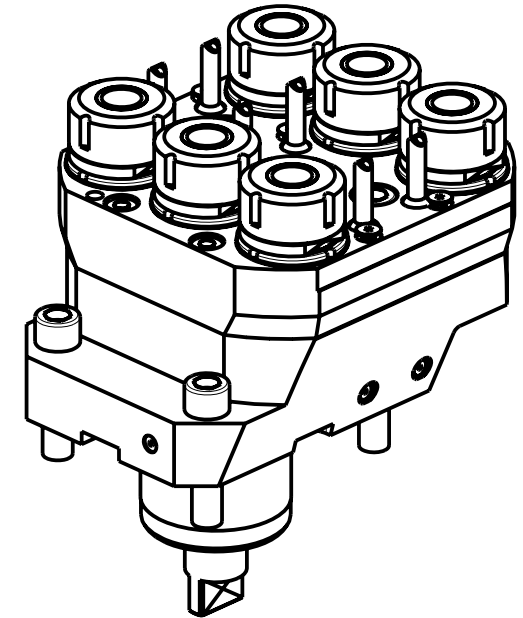
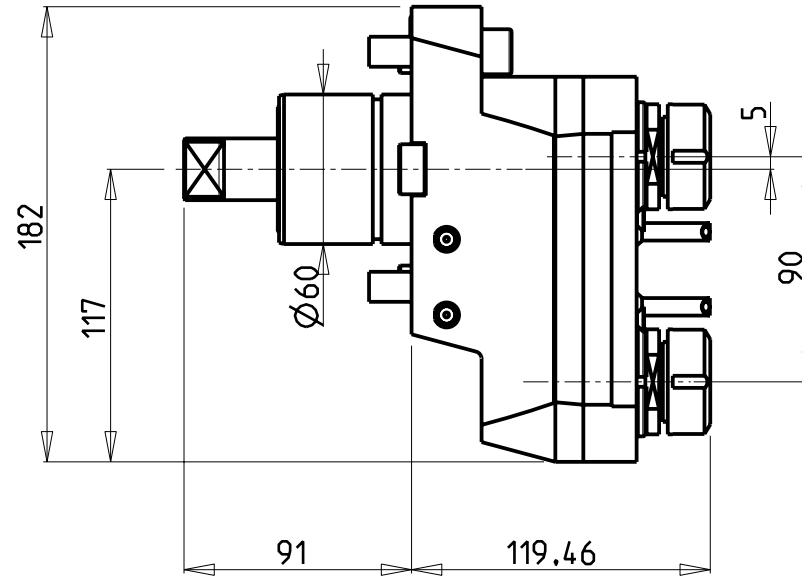
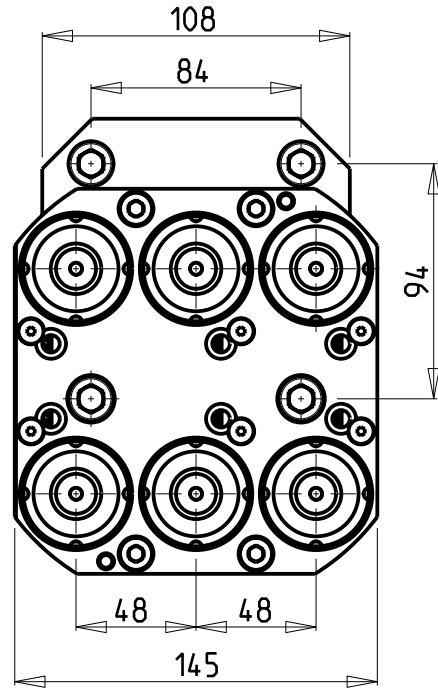

Cod. MT	Mandrino Spindle Spindel	I	RPM	Coppia Max Max Torque Max Drehmoment	N°Utensili N° Tools N° Werkzeuge	Reversibile lato mandrino/contromandrino Reversible sub/main spindle side Umkehrbare Spindel-seite/ Gegenspindel-seite	Lubrificazione est. Ext. coolant Auslenkuehlung	CHIAVI INCLUSE Keys included Schluessel inbegriffen
GDW 0160625	ER25	1:1	6000	20Nm	6	X	X	MNL0210007 MNL0210008

GOODWAY
MOD: GS2600/2800

MODULO MOTORIZZATO RADIALE 6 USCITE
Radial multiple 6 outlet driven tool
Radial angetriebenes Mehrspindel-Werkzeug 6 Ausgaenge

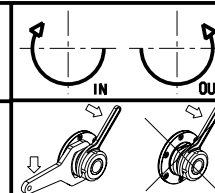

M.T. srl
Via Casino Albini 480
Tel. 0541/956034-957884
Fax 0541/956341
47842 S. GIOVANNI IN M. (RN)
e-mail: mtma@mtmarchetti.com
http://www.mtmarchetti.com

PRODUZIONE MODULI ROTANTI



PAGINA GDW 110-1-00

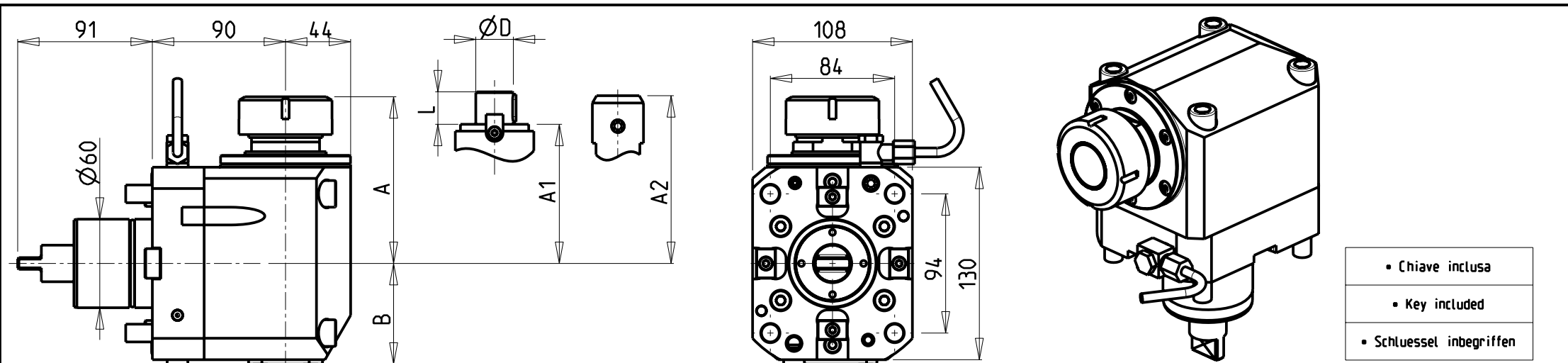

- Chiave inclusa
- Key included
- Schlüssel inbegriffen

Cod. MT	Mandrino Spindle Spindel	I	RPM	Coppia Max Max Torque Max Drehmoment	Reversibile lato mandrino/contromandrino Reversible sub/main spindle side Umkehrbare Spindel-seite/ Gegenspindel-seite	Lubr.interna Coolant through Innenkuehlung	Lubr.esterna Ext. coolant Aussenkuehlung	A	A1	A2	B	D	L	CHIAVI NON INCLUDE Keys not included Schlüssel nicht inbegriffen	
GDW 0010532	ER32	1:1	6000	70Nm	X		X	110.6	-	-	69	-	-	CHUB46	CHSTER32
GDW 0010140	ER40	1:1	6000	70Nm	X		X	112.6	-	-	69	-	-	CHUB46	CHSTER40
GDW 0010332	ER A 32	1:1	6000	70Nm	X		X	98.5	-	-	69	-	-	CHUB46	CHUB32
GDW 0011532	ER32	1:1	6000	70Nm	X	P=70bar	X	110.6	-	-	91.5	-	-	CHUB46	CHSTER32
GDW 0011140	ER40	1:1	6000	70Nm	X	P=70bar	X	112.6	-	-	91.5	-	-	CHUB46	CHSTER40
GDW 0010432	ER A 32	1:1	6000	70Nm	X	P=70bar	X	98.5	-	-	91.5	-	-	CHUB46	CHUB32
GDW 0011617	Ø16x17	1:1	6000	70Nm	X		X	-	87.5	-	69	16	17	CHUB46	CH_VTCROCE_M08 •
GDW 0012219	Ø22x19	1:1	6000	70Nm	X		X	-	87.5	-	69	22	19	CHUB46	CH_VTCROCE_M10 •
GDW 0012721	Ø27x21	1:1	6000	70Nm	X		X	-	87.5	-	69	27	21	CHUB46	CH_VTCROCE_M12 •
GDW 0012519	Ø1"x19	1:1	6000	70Nm	X		X	-	87.5	-	69	1"	19	CHUB46	CH_VTCROCE_M12 •
GDW 0010120	WELDON 20	1:1	6000	70Nm	X		X	-	-	105.5	69	-	-		
GDW 0010125	WELDON 25	1:1	6000	70Nm	X		X	-	-	115	69	-	-		
GDW 0010132	WELDON 32	1:1	6000	70Nm	X		X	-	-	131.5	69	-	-		
GDW 0010220	WELDON 20	1:1	6000	70Nm	X	P=70bar	X	-	-	105.5	91.5	-	-		
GDW 0010225	WELDON 25	1:1	6000	70Nm	X	P=70bar	X	-	-	115	91.5	-	-		

GOODWAY
 MOD: GS2600/2800
 MODULO MOTORIZZATO ASSIALE
 Axial driven tool
 Axial angetriebenes Werkzeug

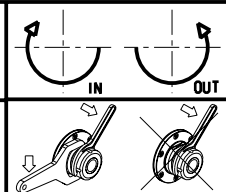

M.T. srl
 Via Casino Albini 480
 Tel. 0541/956034-957884
 Fax 0541/956341
 47842 S. GIOVANNI IN M. (RN)
 e-mail: mtma@mtmarchetti.com
 http://www.mtmarchetti.com

PRODUZIONE MODULI ROTANTI

PAGINA GDW 150-1-10

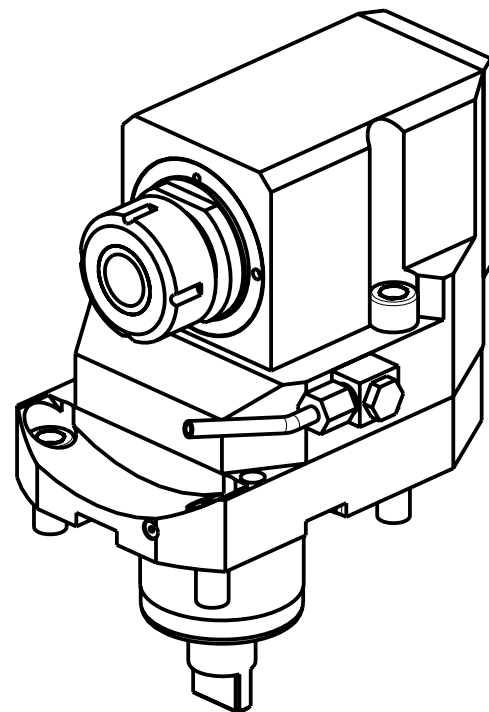
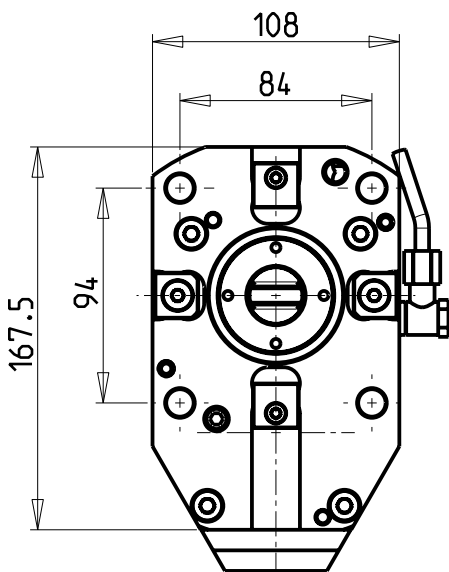
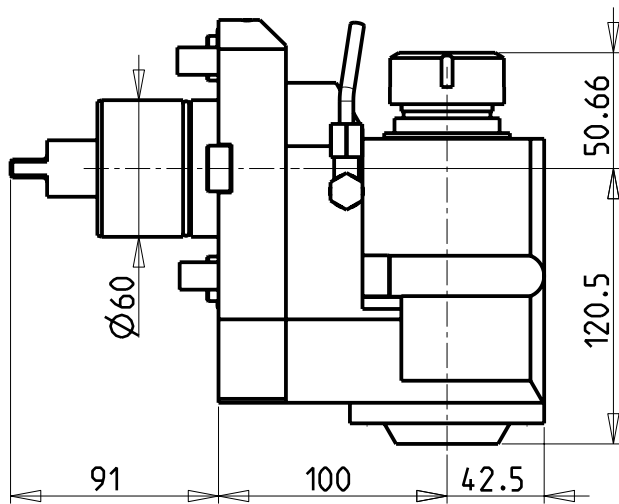
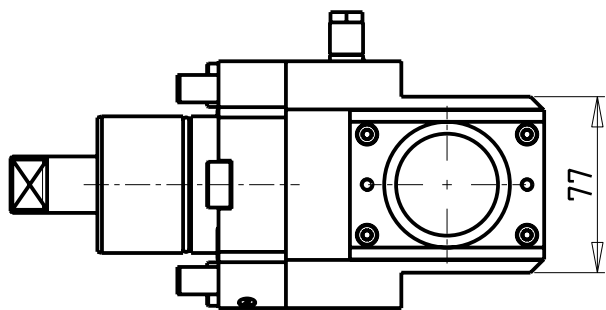

Cod. MT	Mandrino Spindle Spindel	I	RPM	Coppia Max Max Torque Max Drehmoment	Reversibile lato mandrino/contromandrino Reversible sub/main spindle side Umkehrbare Spindel-seite/ Gegenspindel-seite	Lubrificazione int. Coolant through Innenkuehlung	Lubrificazione est. Ext. coolant Aussenkuehlung	A	CHIAVI NON INCLUSE Keys not included Schluessel nicht einbegriffen	
GDW 0170632	ER32	1:1	6000	70Nm	X		X	121	CHUB46	CHSTER32
GDW 0171632	ER32	1:1	6000	70Nm	X	P=70bar	X	135	CHUB46	CHSTER32

GOODWAY
MOD: GS2600/2800

MODULO MOTORIZZATO ASSIALE ARRETRATO

Axial rear-set driven tool

Axial angetriebenes Werkzeug zurueckversetzt

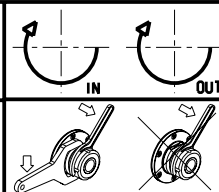

M.T. srl

Via Casino Albini 480
Tel. 0541/956034-957884
Fax 0541/956341

47842 S. GIOVANNI IN M. (RN)
e-mail: mtma@mtmarchetti.com
http://www.mtmarchetti.com

PRODUZIONE MODULI ROTANTI



PAGINA GDW 180-1-10

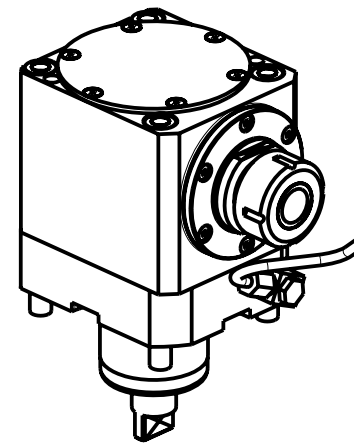
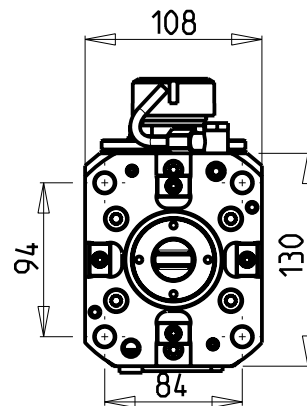
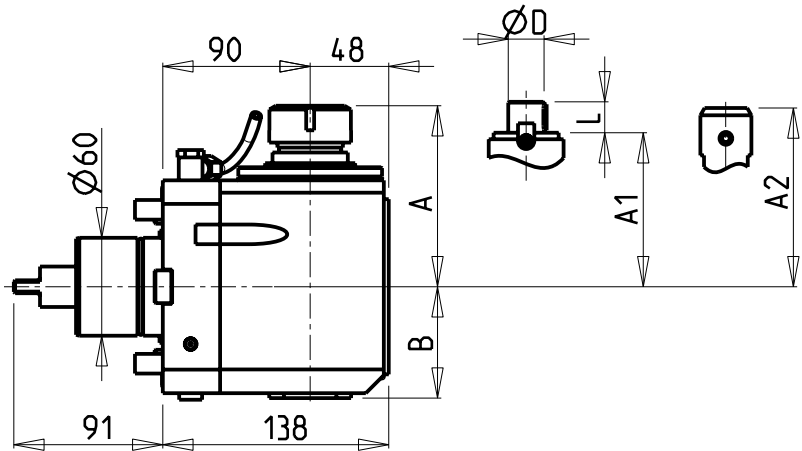

- Chiave inclusa
- Key included
- Schluessel inbegriffen

Cod. MT	Mandrino Spindle Spindel	I	RPM	Coppia Max Max Torque Max Drehmoment	Reversibile lato mandrino/contromandrino Reversible sub/main spindle side Umkehrbare Spindel-seite/ Gegenspindel-seite	Lubrificazione int. Coolant through Innenkühlung	Lubrificazione est. Ext. coolant Aussenkühlung	A	A1	A2	B	D	L	CHIAVI NON INCLUSE Keys not included Schluessel nicht einbegriffen	
														CHUB46	CHSTER32
GDW 0180532	ER32	2:1	3000	100Nm	X		X	110.56	-	-	68	-	-	CHUB46	CHSTER32
GDW 0181532	ER32	2:1	3000	100Nm	X	P=70bar	X	110.56	-	-	91.5	-	-	CHUB46	CHSTER32
GDW 0180140	ER40	2:1	3000	100Nm	X		X	113.16	-	-	68	-	-	CHUB46	CHSTER40
GDW 0181140	ER40	2:1	3000	100Nm	X	P=70bar	X	113.16	-	-	91.5	-	-	CHUB46	CHSTER40
GDW 0181617	Ø16X17	2:1	3000	100Nm	X		X	-	87.5	-	68	16	17	CHUB46	CH_VTCROCE_M08 •
GDW 0182219	Ø22X19	2:1	3000	100Nm	X		X	-	87.5	-	68	22	19	CHUB46	CH_VTCROCE_M10 •
GDW 0182721	Ø27x21	2:1	3000	100Nm	X		X	-	87.5	-	68	27	21	CHUB46	CH_VTCROCE_M12 •
GDW 0182519	Ø1''X19	2:1	3000	100Nm	X		X	-	87.5	-	68	1''	19	CHUB46	CH_VTCROCE_M12 •
GDW 0180120	WELDON 20	2:1	3000	100Nm	X		X	-	-	105.5	68	-	-		
GDW 0180220	WELDON 20	2:1	3000	100Nm	X	P=70bar	X	-	-	105.5	91.5	-	-		
GDW 0180125	WELDON 25	2:1	3000	100Nm	X		X	-	-	115	68	-	-		
GDW 0180225	WELDON 25	2:1	3000	100Nm	X	P=70bar	X	-	-	115	91.5	-	-		
GDW 0180132	WELDON 32	2:1	3000	100Nm	X		X	-	-	131.5	68	-	-		
GDW 0180232	WELDON 32	2:1	3000	100Nm	X	P=70bar	X	-	-	131.5	91.5	-	-		

GOODWAY
MOD: GS2600/2800

MODULO MOTORIZZATO ASSIALE RIDOTTO I=2:1
Axial geared-down I=2:1 driven tool
Axial angetriebenes Werkzeug untersetzt I=2:1

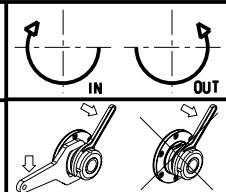

M.T. srl
Via Casino Albini 480
Tel. 0541/956034-957884
Fax 0541/956341
47842 S. GIOVANNI IN M. (RN)
e-mail: mtma@mtmarchetti.com
http://www.mtmarchetti.com

PRODUZIONE MODULI ROTANTI

PAGINA GDW 190-1-10

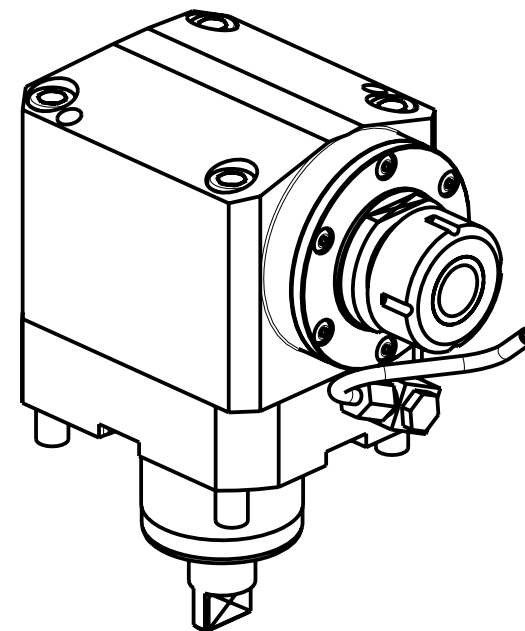
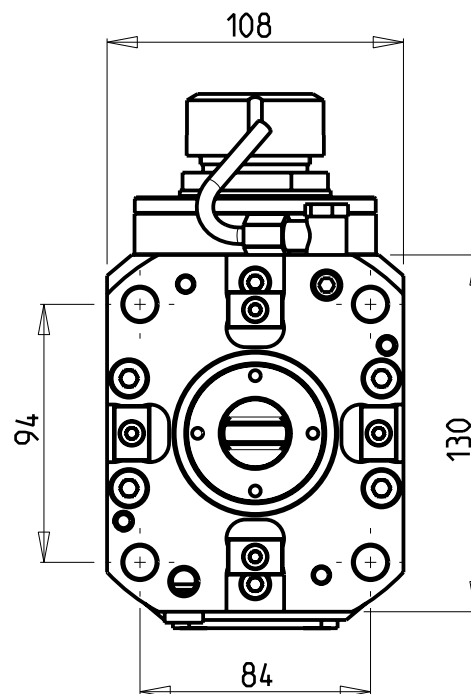
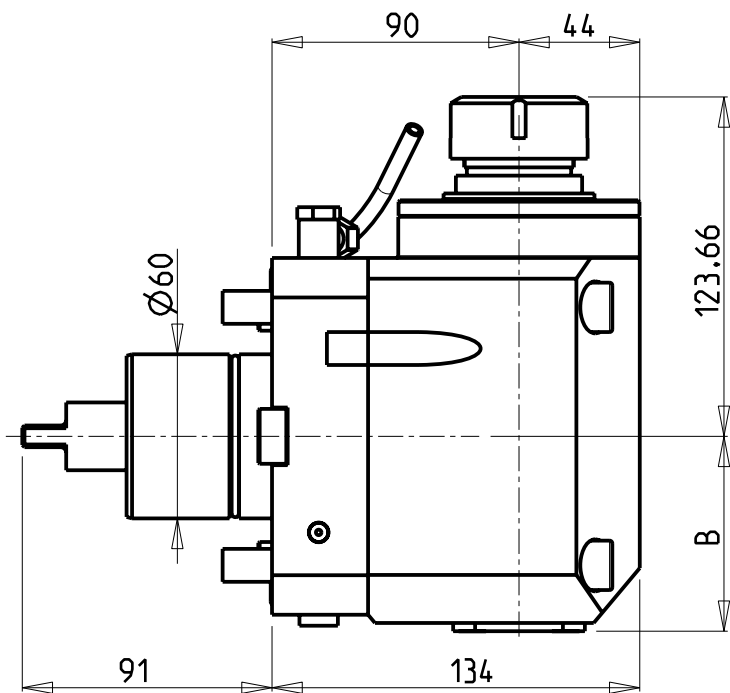

Cod. MT	Mandrino Spindle Spindel	I	RPM	Coppia Max Max Torque Max Drehmoment	Reversibile lato mandrino/contromandrino Reversible sub/main spindle side Umkehrbare Spindel-seite/ Gegenspindel-seite	Lubrificazione int. Coolant through Innenkühlung	Lubrificazione est. Ext. coolant Aussenkühlung	B	CHIAVI NON INCLUSE Keys not included Schlüssel nicht einbegriffen	
GDW 0190532	ER32	1:2	12000	50Nm	X		X	71	CHUB46	CHSTER32
GDW 0191532	ER32	1:2	12000	50Nm	X	P=70bar	X	94.5	CHUB46	CHSTER32

GOODWAY
MOD: GS2600/2800

MODULO MOTORIZZATO ASSIALE MOLTIPLICATO I=1:2
Axial geared-up I=1:2 driven tool
Axial angetriebenes Werkzeug uebersetzt I=1:2

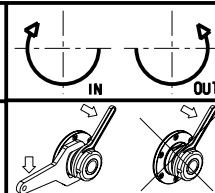

M.T. srl
Via Casino Albini 480
Tel. 0541/956034-957884
Fax 0541/956341
47842 S. GIOVANNI IN M. (RN)
e-mail: mtma@mtmarchetti.com
http://www.mtmarchetti.com

PRODUZIONE MODULI ROTANTI



PAGINA GDW 200-1-10

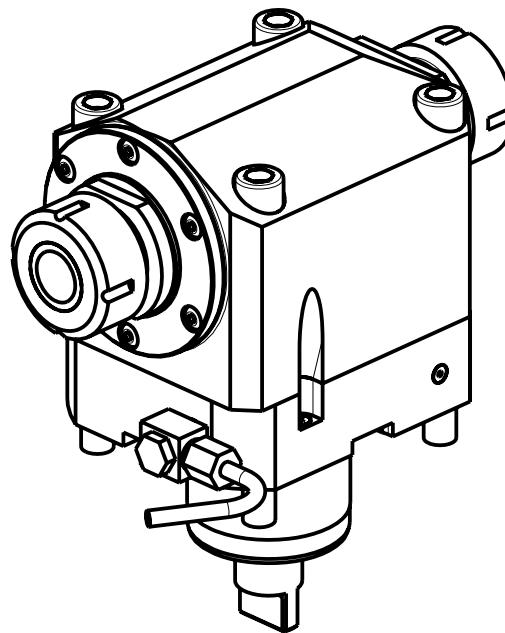
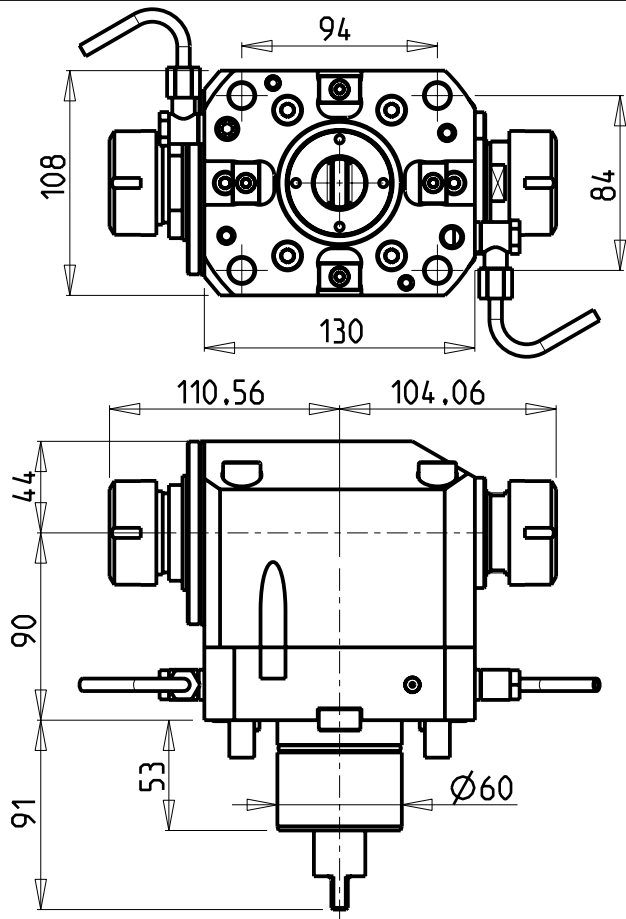

ATTENZIONE - ATTENTION - ACHTUNG

- Per lo smontaggio degli utensili utilizzare sempre la chiave di contrasto come indicato nel manuale d'uso.
- For disassembly of the tools use always the contrast key as mentioned in the user instructions.
- Fuer das Abmontieren der Werkzeuge immer den Gegenschlüssel benutzen wie in der Bedienungsanleitung erwäohnt.

Cod. MT	Mandrino Spindle Spindel	I	RPM	Coppia Max Max Torque Max Drehmoment	Reversibile lato mandrino/contromandrino Reversible sub/main spindle side Umkehrbare Spindel-seite/ Gegenspindel-seite	Lubr.esterna Ext. coolant Aussenkuehlung	CHIAVI NON INCLUSE Keys not included Schlüssel nicht einbegriffen		
GDW 0030232	ER32+ER32	1:1	6000	70Nm	X	X	CHUB46	CHUB36	CHSTER32

GOODWAY
MOD: GS2600/2800

MODULO MOTORIZZATO ASSIALE BISPORGENTE
Axial opposite face twin driven tool
Axial angetriebenes Werkzeug halb vorspringend

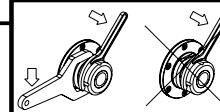

M.T. srl

Via Casino Albini 480
Tel. 0541/956034-957884
Fax 0541/956341
47842 S. GIOVANNI IN M. (RN)
e-mail: mtma@mtmarchetti.com
http://www.mtmarchetti.com

PRODUZIONE MODULI ROTANTI



PAGINA GDW 240-1-10

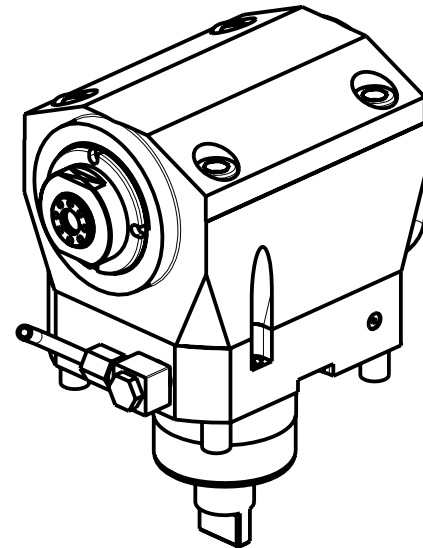
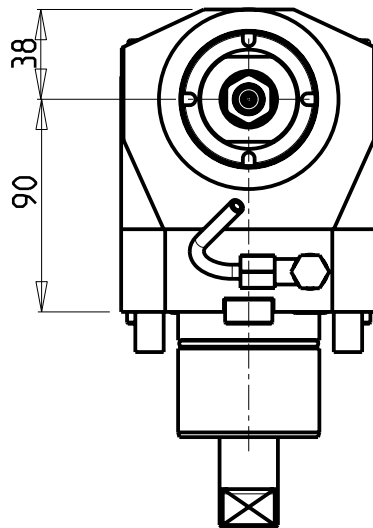
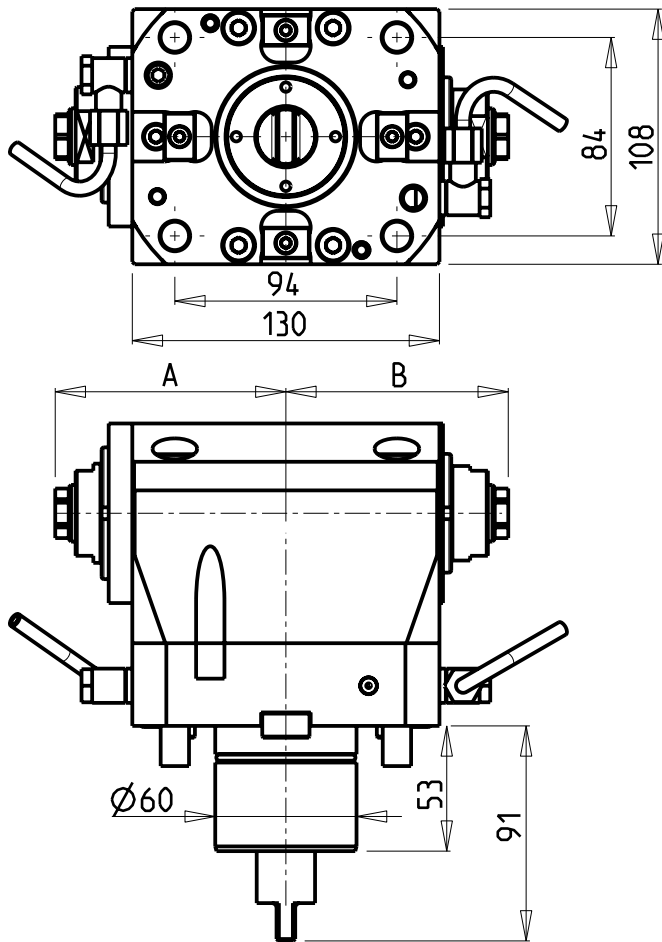

ATTENZIONE - ATTENTION - ACHTUNG

- Per lo smontaggio degli utensili utilizzare sempre la chiave di contrasto come indicato nel manuale d'uso.
- For disassembly of the tools use always the contrast key as mentioned in the user instructions.
- Fuer das Abmontieren der Werkzeuge immer den Gegenschlüssel benutzen wie in der Bedienungsanleitung erwahnt.

Cod. MT	Mandrino Spindle Spindel	I	RPM	Coppia Max Max Torque Max Drehmoment	Reversibile lato mandrino/contromandrino Reversible sub/main spindle side Umkehrbare Spindel-seite/ Gegenspindel-seite	Lubr.esterna Ext. coolant Ausseukuehlung	A	B	CHIAVI NON INCLUSE Keys not included Schluessel nicht einbegriffen	
GDW 0200116	ERA16+ERA16	1:2	12000	50Nm	X	X	97.63	94.13	CHUB36	CHUB19_SP3
GDW 0200120	ERA20+ERA20	1:2	12000	50Nm	X	X	95.73	93.73	CHUB36	CHUB22

GOODWAY
MOD: GS2600/2800

MODULO MOTORIZZATO ASSIALE BISPORGENTE MOLTIPLICATO I=1:2
Axial geared-up I=1:2 opposite face twin driven tool
Axial angetriebenes Werkzeug halb vorspringend uebersetzt I=1:2

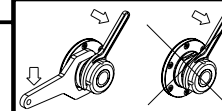

M.T. srl

Via Casino Albini 480
Tel. 0541/956034-957884
Fax 0541/956341
47842 S. GIOVANNI IN M. (RN)
e-mail: mtma@mtmarchetti.com
http://www.mtmarchetti.com

PRODUZIONE MODULI ROTANTI



PAGINA GDW 250-1-10

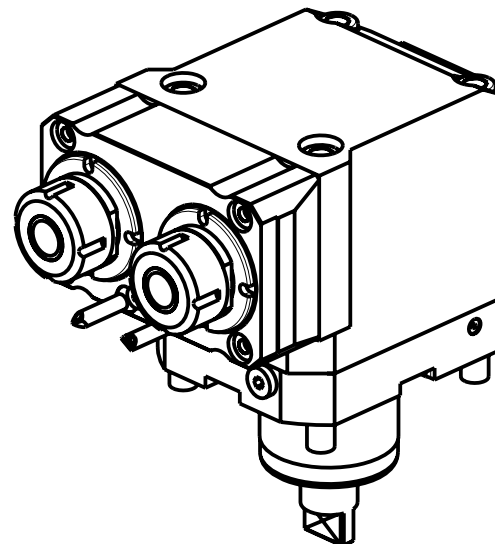
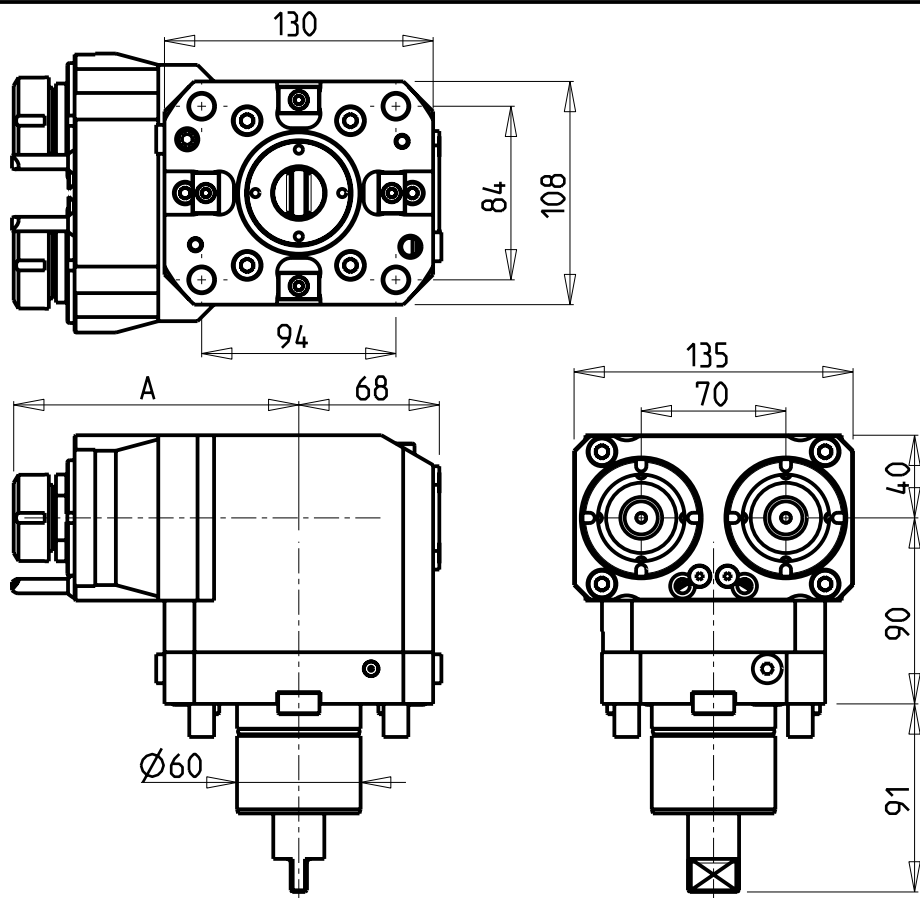

ATTENZIONE - ATTENTION - ACHTUNG

- Per lo smontaggio degli utensili utilizzare sempre la chiave di contrasto come indicato nel manuale d'uso.
- For disassembly of the tools use always the contrast key as mentioned in the user instructions.
- Fuer das Abmontieren der Werkzeuge immer den Gegenschlüssel benutzen wie in der Bedienungsanleitung erwahnt.

GDW 0211325

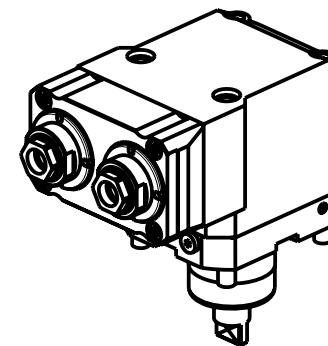

Cod. MT	Mandrino Spindle Spindel	I	RPM	Coppia Max Max Torque Max Drehmoment	Reversibile lato mandrino/contromandrino Reversible sub/main spindle side Umkehrbare Spindelseite/ Gegenspindelseite	Lubr.interna Coolant through Innenkuehlung	Lubr.esterna Ext. coolant Aussenkuehlung	A	CHIAVI NON INCLUSE Keys not included Schluessel nicht einbegriffen	
GDW 0210225	ER25	1:1	6000	40Nm	X		X	137.96	CHUB36	CHSTER25
GDW 0211225	ER25	1:1	6000	40Nm	X	P=70bar	X	162.66	CHUB36	CHSTER25
GDW 0211325	ER A 25	1:1	6000	40Nm	X	P=70bar	X	156.03	CHUB38	CHUB27

GOODWAY
MOD: GS2600/2800

MODULO MOTORIZZATO ASSIALE 2 USCITE IN Y
Axial Single side twin head driven tool in Y
Axial angetriebenes Werkzeug 2 Ausgaenge in Y

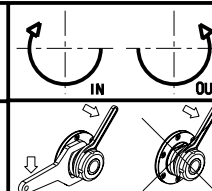

M.T. srl

Via Casino Albini 480
Tel. 0541/956034-957884
Fax 0541/956341

47842 S. GIOVANNI IN M. (RN)
e-mail: mtma@mtmarchetti.com
http://www.mtmarchetti.com

PRODUZIONE MODULI ROTANTI



PAGINA GDW 260-1-10

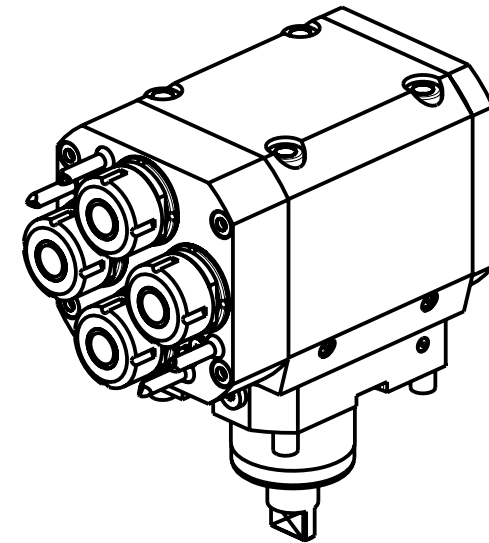
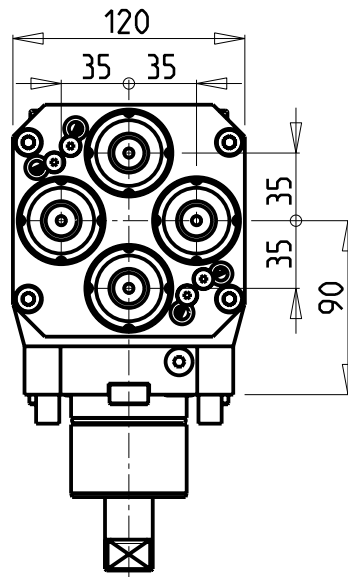
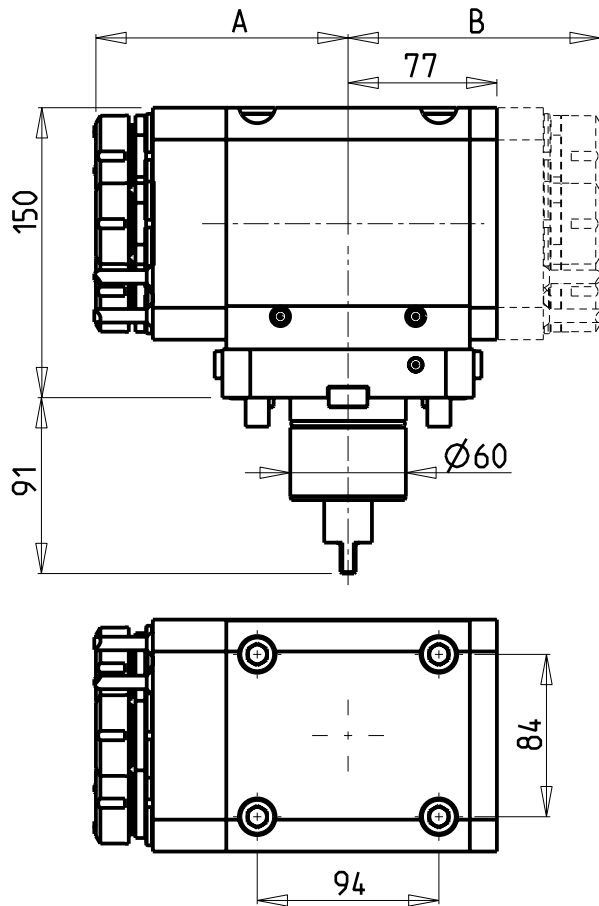

ATTENZIONE - ATTENTION - ACHTUNG

- Per lo smontaggio degli utensili utilizzare sempre la chiave di contrasto come indicato nel manuale d'uso.
- For disassembly of the tools use always the contrast key as mentioned in the user instructions.
- Fuer das Abmontieren der Werkzeuge immer den Gegenschlüssel benutzen wie in der Bedienungsanleitung erwäehnt.

Cod. MT	Mandrino Spindle Spindel	I	RPM	Coppia Max Max Torque Max Drehmoment	N°Utensili N°Tools N°Werkzeuge	Reversibile lato mandrino/contromandrino Reversible sub/main spindle side Umkehrbare Spindel-seite/ Gegenspindel-seite	Lubr.esterna Ext. coolant Aussenkeuhlung	A	B	CHIAVI INCLUDE Keys included Schluessel inbegriffen	
GDW 0220425	ER25	1:1	6000	30Nm	4	X	X	130.46	-	MNL0210007	MNL0210008
GDW 0224425	ER25+ER25	1:1	6000	30Nm	4+4		X	130.46	130.46	MNL0210007	MNL0210008

GOODWAY
 MOD: GS2600/2800
 MODULO MOTORIZZATO ASSIALE 4/8 USCITE
 Axial multiple 4/8 outlet driven tool
 Axial angetriebenes Mehrspindel-Werkzeug 4/8 Ausgaenge

M.T. srl
 Via Casino Albini 480
 Tel. 0541/956034-957884
 Fax 0541/956341
 47842 S. GIOVANNI IN M. (RN)
 e-mail: mtma@mtmarchetti.com
 http://www.mtmarchetti.com

PRODUZIONE MODULI ROTANTI



PAGINA GDW 270-1-00

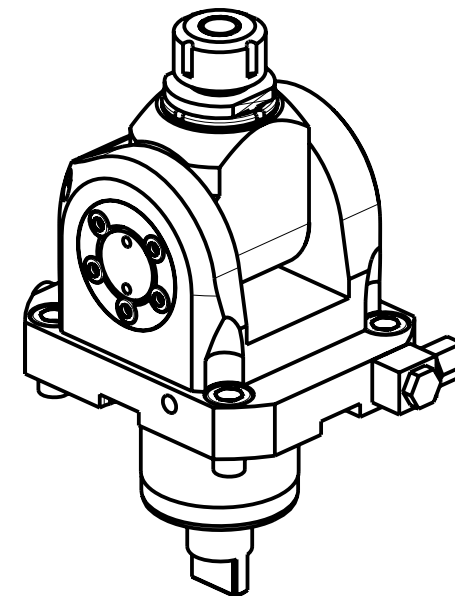
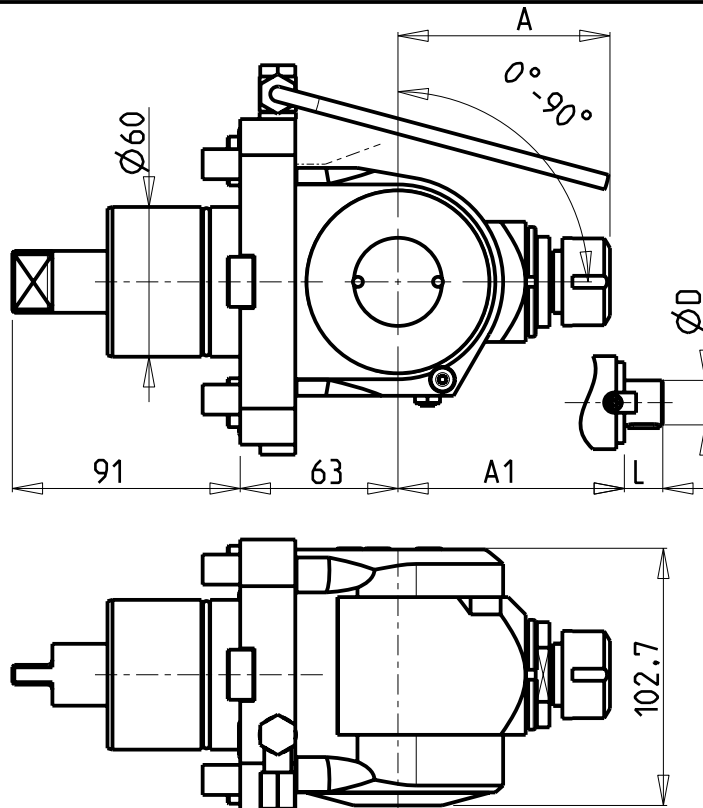
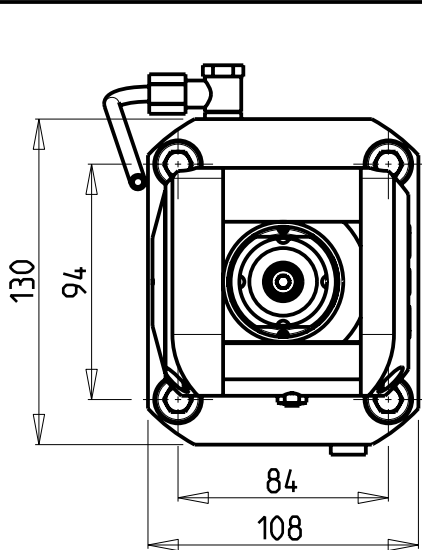

Cod. MT	Mandrino Spindle Spindel	I	RPM	Coppia Max Max Torque Max Drehmoment	Reversibile lato mandrino/contromandrino Reversible sub/main spindle side Umkehrbare Spindel-seite/ Gegenspindel-seite	Lubr.esterna Ext. coolant Aussenkuehlung	A	A1	D	L	CHIAVI INCLUSE Keys included Schluessel inbegriffen		
											CHUB36	CHSTER20	CHESL10
GDW 0040020	ER20	1:1	6000	40Nm	X	X	84.16	-	-	-	CHUB36	CHSTER20	CHESL10
GDW 0040025	ER25	1:1	6000	40Nm	X	X	85.66	-	-	-	CHUB36	CHSTER25	CHESL10
GDW 0041617	Ø16x17	1:1	6000	40Nm	X	X	-	65	16	17	CHUB36	CH_VTCROCE_M08	CHESL10
GDW 0042219	Ø22x19	1:1	6000	40Nm	X	X	-	66	22	19	CHUB36	CH_VTCROCE_M10	CHESL10
GDW 0041905	Ø3/4"x3/4"	1:1	6000	40Nm	X	X	-	65	3/4"	3/4"	CHUB36	CH_VTCROCE_M08	CHESL10

GOODWAY
MOD: GS2600/2800

MODULO MOTORIZZATO ORIENTABILE 0-90°
0-90° adjustable angle driven tool
Angetriebenes Werkzeug schwenkbar 0-90°

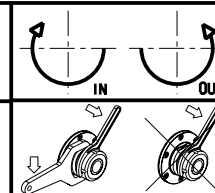

M.T. srl

Via Casino Albini 480
Tel. 0541/956034-957884

Fax 0541/956341

47842 S. GIOVANNI IN M. (RN)
e-mail: mtma@mtmarchetti.com
http://www.mtmarchetti.com

PRODUZIONE MODULI ROTANTI



PAGINA GDW 330-1-00

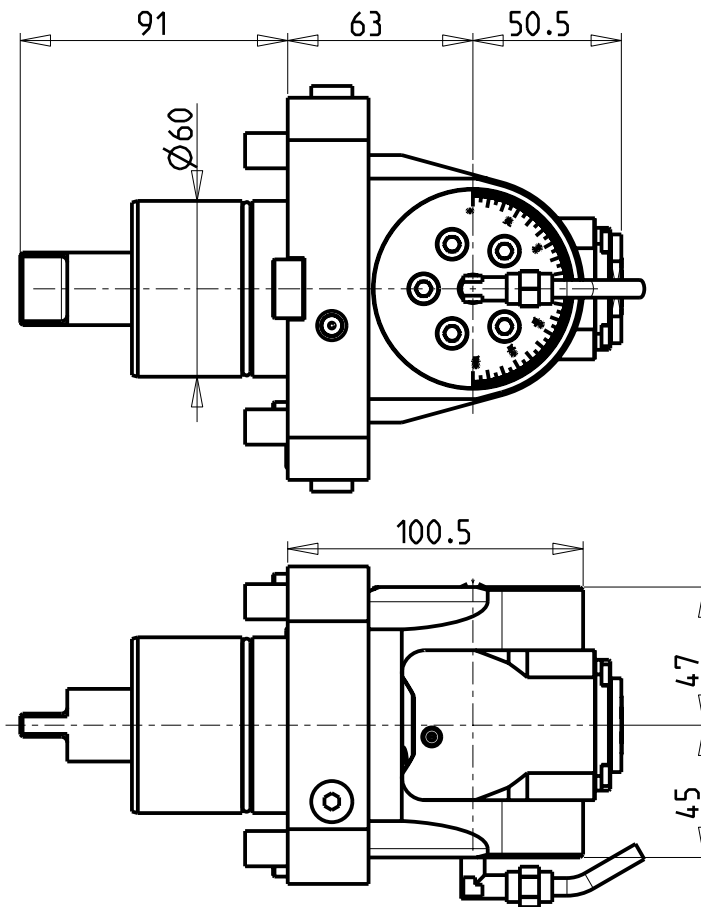
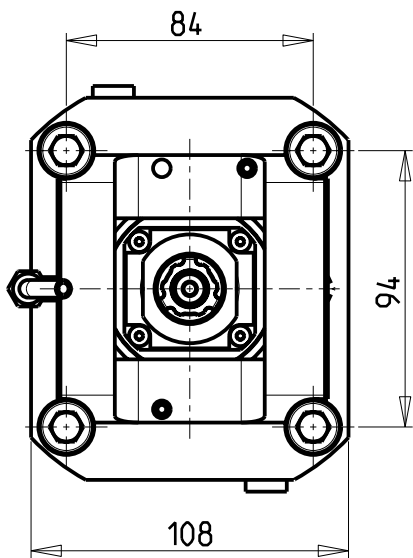

ATTENZIONE - ATTENTION - ACHTUNG

- Per lo smontaggio degli utensili utilizzare sempre la chiave di contrasto come indicato nel manuale d'uso.
- For disassembly of the tools use always the contrast key as mentioned in the user instructions.
- Fuer das Abmontieren der Werkzeuge immer den Gegenschlüssel benutzen wie in der Bedienungsanleitung erwaeht.

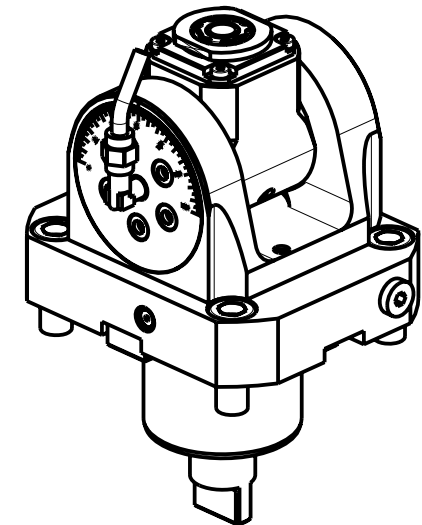

Cod. MT	Mandrino Spindle Spindel	I	RPM	Coppia Max Max Torque Max Drehmoment	Lubrificazione int. Coolant through Innenkuehlung	Lubrificazione est. Ext. coolant Aussenkuehlung	CHIAVI INCLUSE Keys included Schluesssel inbegriffen			
GDW 0440120	ERA20	1:1	6000	30Nm		X	CHUB22	CHUB36	CHTAER20ZC	CHESL10
GDW 0440220	ERA20	1:1	6000	30Nm	P=70bar	X	CHUB22	CHUB36	CHTAER20ZC	CHESL10

NEW

GOODWAY
MOD: GS2600/2800

MODULO MOTORIZZATO ORIENTABILE +/-90°
+/-90° adjustable angle driven tool
Angetriebenes Werkzeug schwenkbar +/-90°

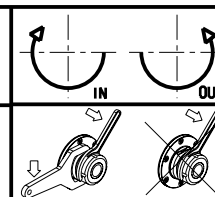

M.T. srl

Via Casino Albini 480
Tel. 0541/956034-957884
Fax 0541/956341

47842 S. GIOVANNI IN M. (RN)
e-mail: mtma@mtmarchetti.com
http://www.mtmarchetti.com

PRODUZIONE MODULI ROTANTI



PAGINA GDW 335-1-00

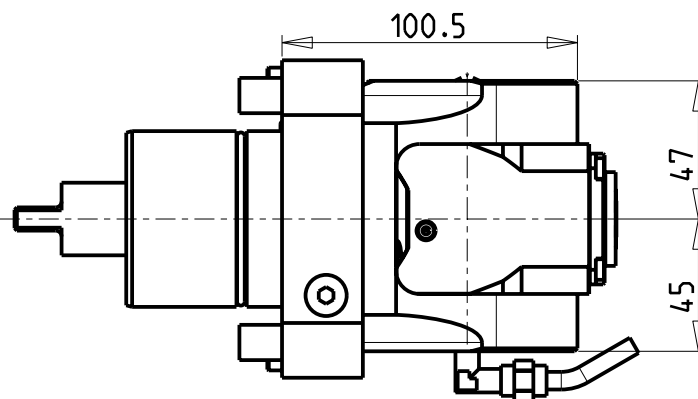
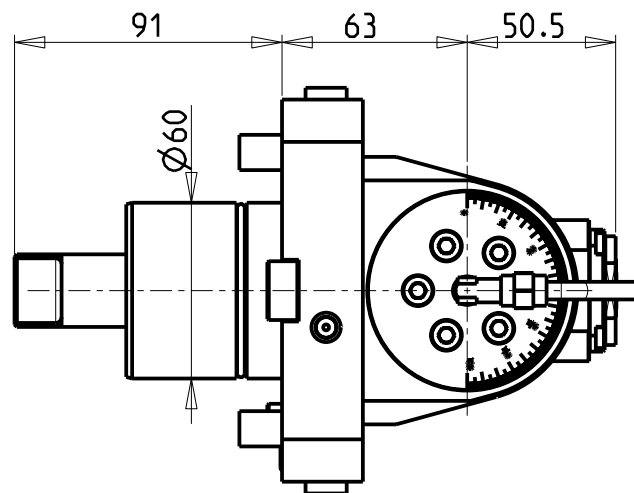
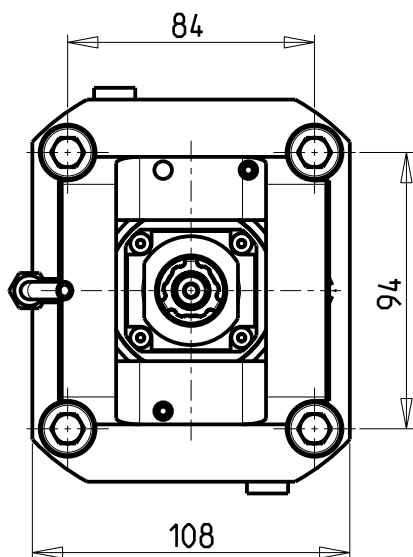

ATTENZIONE - ATTENTION - ACHTUNG

- Per lo smontaggio degli utensili utilizzare sempre la chiave di contrasto come indicato nel manuale d'uso.
- For disassembly of the tools use always the contrast key as mentioned in the user instructions.
- Fuer das Abmontieren der Werkzeuge immer den Gegenschlüssel benutzen wie in der Bedienungsanleitung erwäehnt.

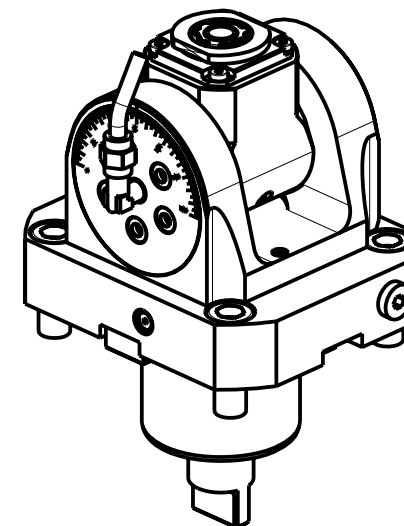

Cod. MT	Mandrino Spindle Spindel	i	RPM	Coppia Max Max Torque Max Drehmoment	Lubrificazione int. Coolant through Innenkuehlung	Lubrificazione est. Ext. coolant Aussenkuehlung	CHIAVI INCLUSE Keys included Schluesssel inbegriffen			
GDW0440316	ERA16	1:2	12000	8Nm		X	CHUB19_SP3	CHUB32	CHTAER16ZC	CHESL10
GDW0440416	ERA16	1:2	12000	8Nm	P=70bar	X	CHUB19_SP3	CHUB32	CHTAER16ZC	CHESL10

GOODWAY
MOD: GS2600/2800

MODULO MOTORIZZATO ORIENTABILE +/-90° MOLTIPLICATO I=1:2
+/-90° adjustable angle driven tool geared-up I=1:2
Angetriebenes Werkzeug schwenkbar +/-90° uebersetzt I=1:2

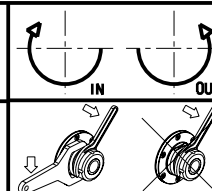

M.T. srl

Via Casino Albini 480
Tel. 0541/956034-957884
Fax 0541/956341

47842 S. GIOVANNI IN M. (RN)
e-mail: mtma@mtmarchetti.com
http://www.mtmarchetti.com

PRODUZIONE MODULI ROTANTI



PAGINA GDW 336-1-00

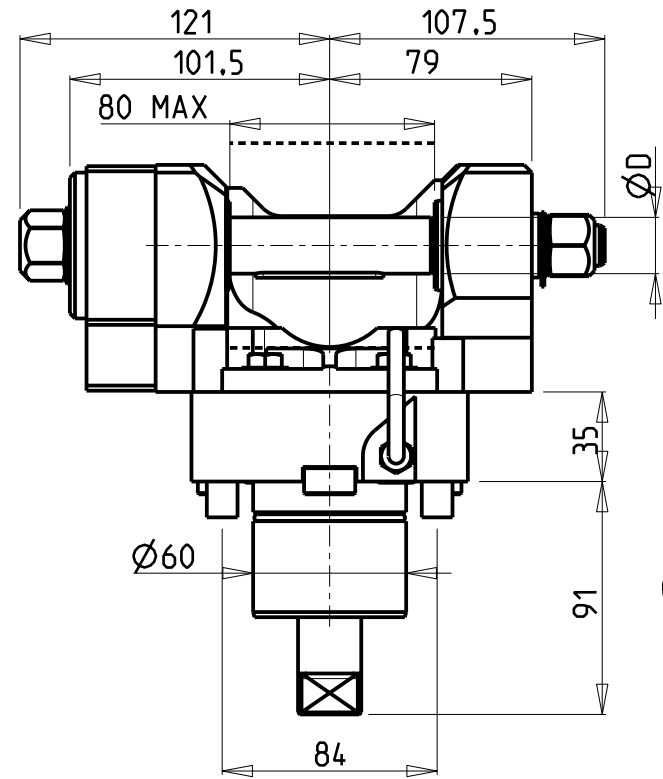
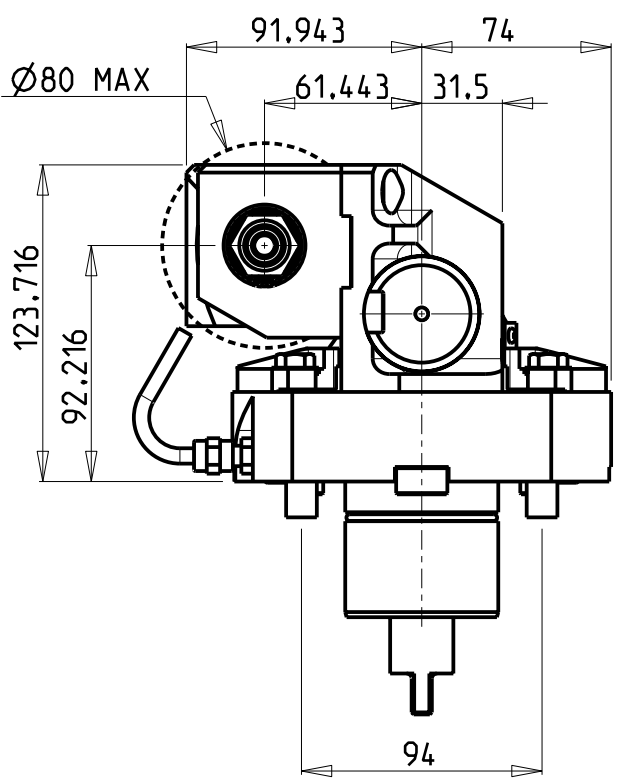

- SU RICHIESTA E' DISPONIBILE UNA STAFFA ANTIROTAZIONE PER LAVORAZIONI PESANTI
- On request we arrange antirotationscrew for heavy working
- Auf Anfrage verfuegen wir ueber Antirotationbolzen fuer schwere Verarbeitungen

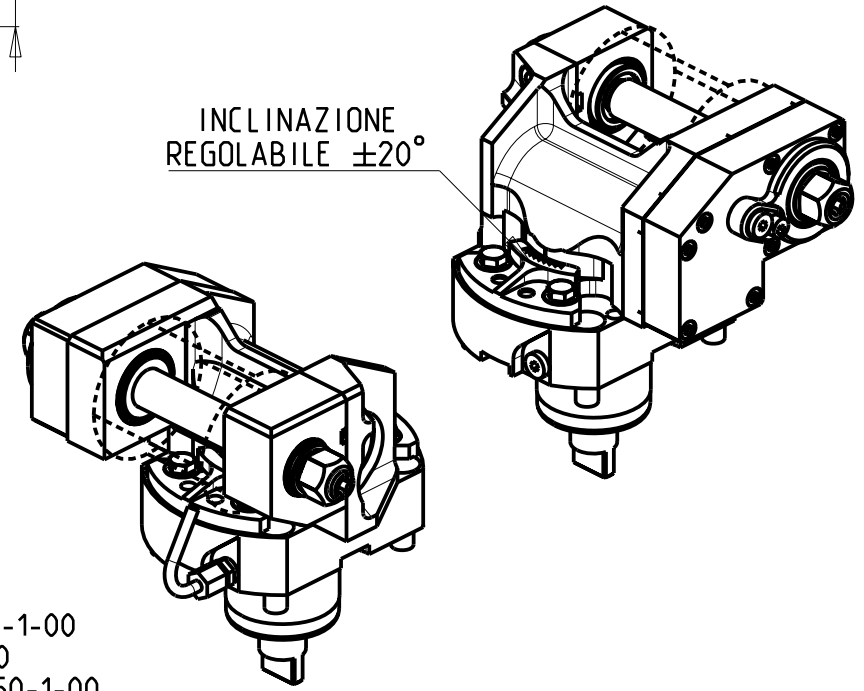

INCLINAZIONE
REGOLABILE ±20°

DOTAZIONI - SUPPLIED WITH - AUSSTATTUNG

- | | |
|-----------|---|
| mm / inch | - N°1 ALBERO + DISTANZIALI
- N°1 SHAFT + SPACER
- N°1 DORN + ABSTANDSSTUECK |
|-----------|---|

PER ALBERI E DISTANZIALI VEDI PAG. TBL250-1-00
FOR SHAFT END SPACER SEE PAGE TBL250-1-00
FUER DORN UND ABSTANDSSTUECK SEITE TBL250-1-00

Cod. MT	I	RPM max	Coppia Max Max Torque Max Drehmoment	Reversibile lato mandrino/contromandrino Reversible sub/main spindle side Umkehrbare Spindel-seite/ Gegenspindel-seite	Lubrificazione est. Ext. coolant Aussenkuehlung	D (mm)	D (Inch)	CHIAVI INCLUSE Keys included Schlüssel inbegriffen			
GDW 0231100	1:1	6000	60Nm	X	X	16-22-27-32	3/4"-1"-1 1/4"	CHUB24	CHUB13	CHESL08	CHESL10
GDW 0232100	2:1	3000	80Nm	X	X	16-22-27-32	3/4"-1"-1 1/4"	CHUB24	CHUB13	CHESL08	CHESL10

GOODWAY
MOD: GS2600/2800

MODULO MOTORIZZATO PORTACREATORE
Driven gear hobber
Angetriebenes Zahnradwaelzfraes-Werkzeug

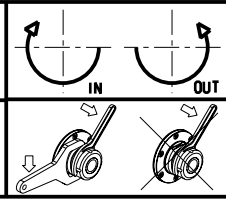

M.T. srl
Via Casino Albini 480
Tel. 0541/956034-957884
Fax 0541/956341
47842 S. GIOVANNI IN M. (RN)
e-mail: mtma@mtmarchetti.com
http://www.mtmarchetti.com

PRODUZIONE MODULI ROTANTI

PAGINA GDW 340-1-00

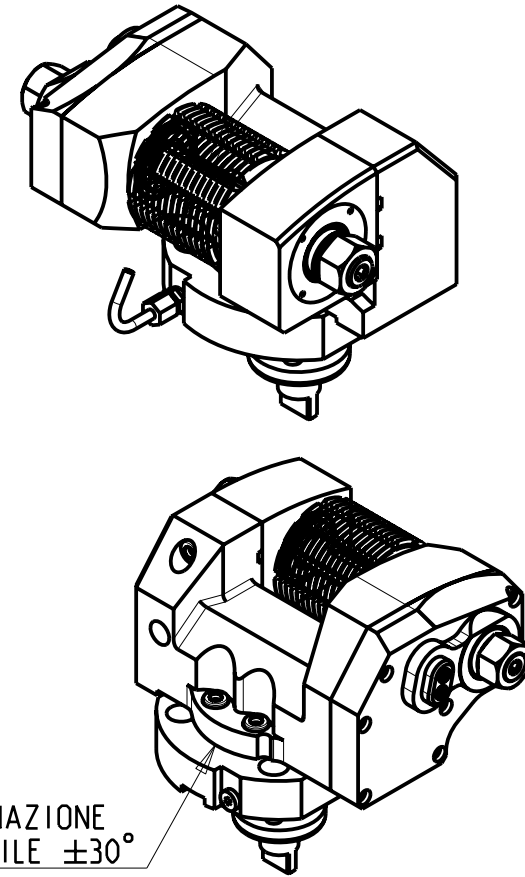
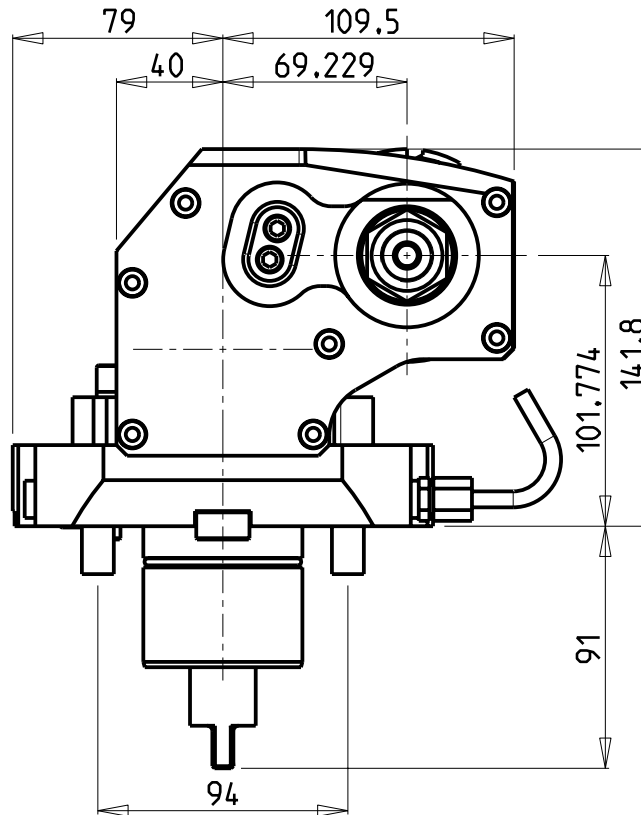
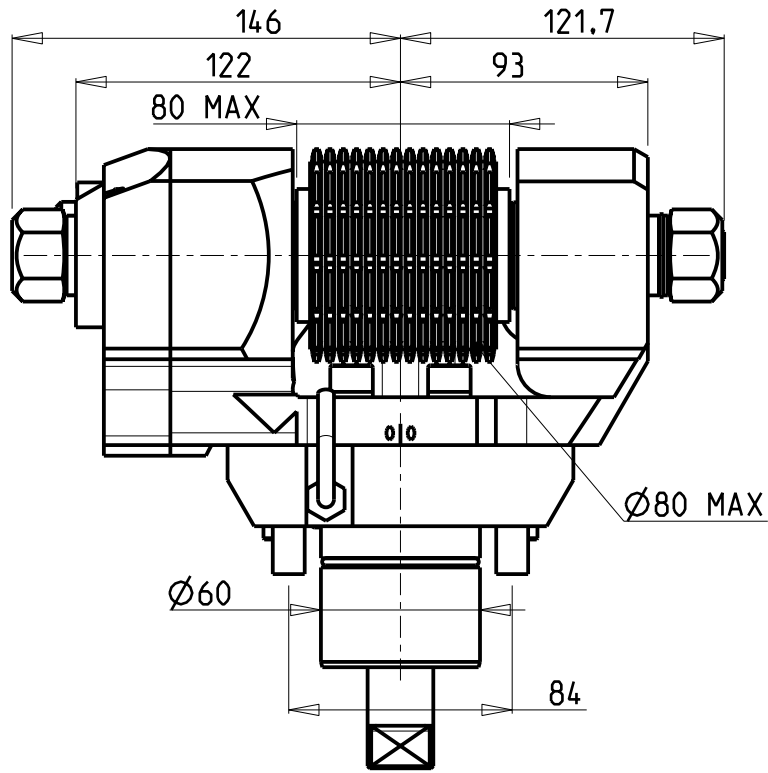

INCLINAZIONE
REGOLABILE $\pm 30^\circ$

DOTAZIONI - SUPPLIED WITH - AUSSTATTUNG

mm / inch

- N°1 ALBERO + DISTANZIALI
- N°1 SHAFT + SPACER
- N°1 DORN + ABSTANDSSTUECK

PER ALBERI E DISTANZIALI VEDI PAG. TBL250-1-00
FOR SHAFT END SPACER SEE PAGE TBL250-1-00
FUER DORN UND ABSTANDSSTUECK SEITE TBL250-1-00

Cod. MT	I	RPM max	Coppia Max Max Torque Max Drehmoment	Reversibile lato mandrino/contromandrino Reversible sub/main spindle side Umkehrbare Spindel-seite/ Gegenspindel-seite	Lubrificazione est. Ext. coolant Aussenkuehlung	D (mm)	D (Inch)	CHIAVI INCLUSE Keys included Schlüssel inbegriffen			
								CHUB30	CHESL08	CHESL10	CHUB24 (Ø16 / Ø3/4")
GDW 024 1100	1:1	6000	90Nm	X	X	16-22-27-32	3/4"-1"-1 1/4"	CHUB30	CHESL08	CHESL10	CHUB24 (Ø16 / Ø3/4")
GDW 024 2100	2:1	3000	110Nm	X	X	16-22-27-32	3/4"-1"-1 1/4"	CHUB30	CHESL08	CHESL10	CHUB24 (Ø16 / Ø3/4")

GOODWAY

MOD: GS2600/2800

MODULO MOTORIZZATO PORTACREATORE MAGGIORATO

Reinforced driven gear hobber

Angetriebenes Zahnradwaelzfraes-Werkzeug vergroessert

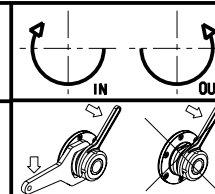

M.T. srl

Via Casino Albini 480
Tel. 0541/956034-957884

Fax 0541/956341

47842 S. GIOVANNI IN M. (RN)

e-mail: mtma@mtmarchetti.com

http://www.mtmarchetti.com

PRODUZIONE MODULI ROTANTI



PAGINA GDW 340-1-60

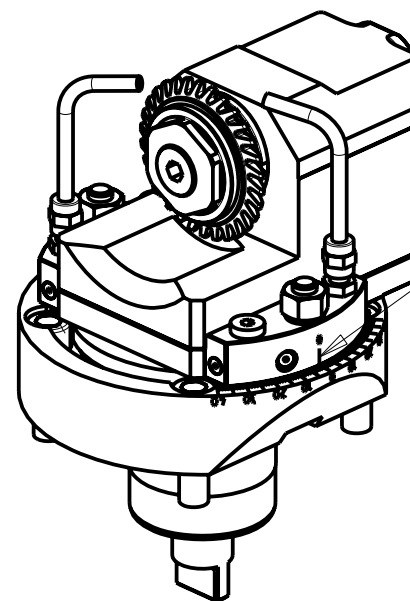
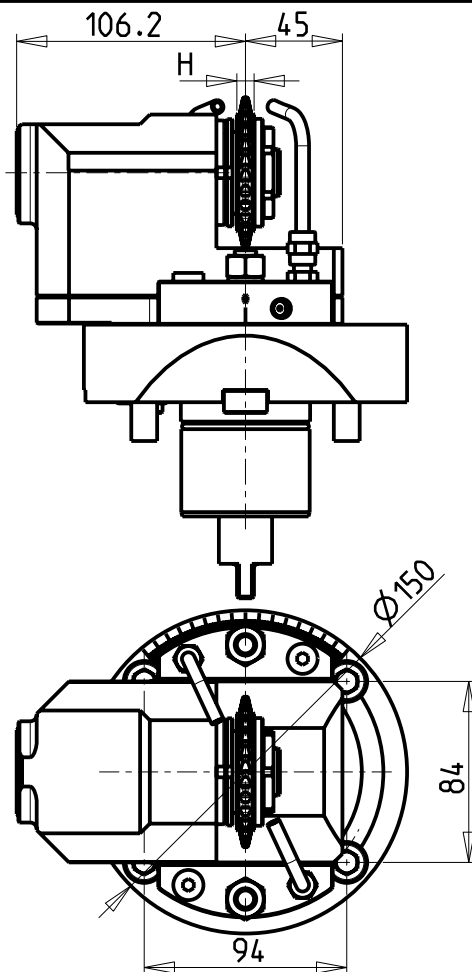
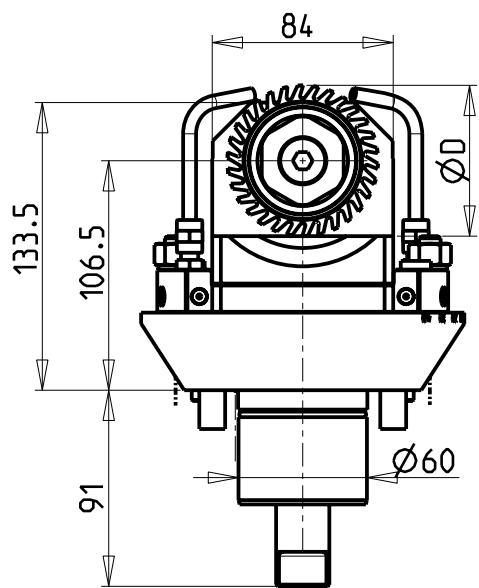

INCLINAZIONE
REGOLABILE $\pm 31^\circ$

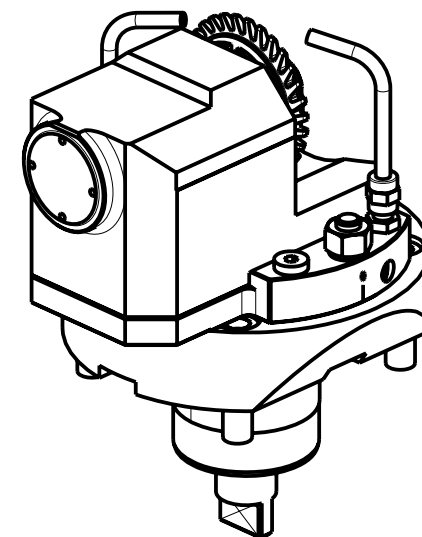

Cod. MT	Mandrino Spindle Spindel	I	RPM	Coppia Max Max Torque Max Drehmoment	Reversibile lato mandrino/contromandrino Reversible sub/main spindle side Umkehrbare Spindel-seite/ Gegenspindel-seite	Lubrificazione est. Ext. coolant Aussenkuehlung	\varnothing	H	CHIAVI INCLUSE Keys included Schluessel einbegriffen			
GDW 0258022	$\varnothing 22 \times 12$	1:1	6000	50Nm	X	X	63-70-80	MAX 12	CHUB38	CHUB17	CHESL10	CHESL08
GDW 0258125	$\varnothing 1" \times 12$	1:1	6000	50Nm	X	X	63-70-80	MAX 12	CHUB38	CHUB17	CHESL10	CHESL08

GOODWAY
MOD: GS2600/2800

MODULO MOTORIZZATO PER VITI SENZA FINE

Driven tool for worm screws

Angetriebenes Werkzeug fuer schrauben ohne ende

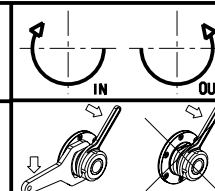

M.T. srl

Via Casino Albini 480
Tel. 0541/956034-957884
Fax 0541/956341

47842 S. GIOVANNI IN M. (RN)
e-mail: mtma@mtmarchetti.com
http://www.mtmarchetti.com

PRODUZIONE MODULI ROTANTI



PAGINA GDW 359-1-00

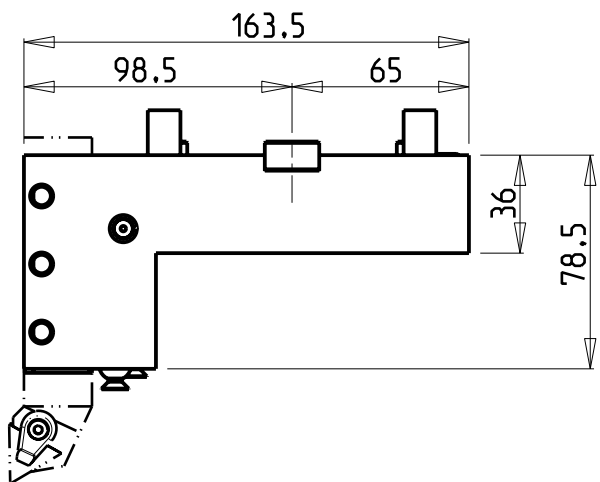
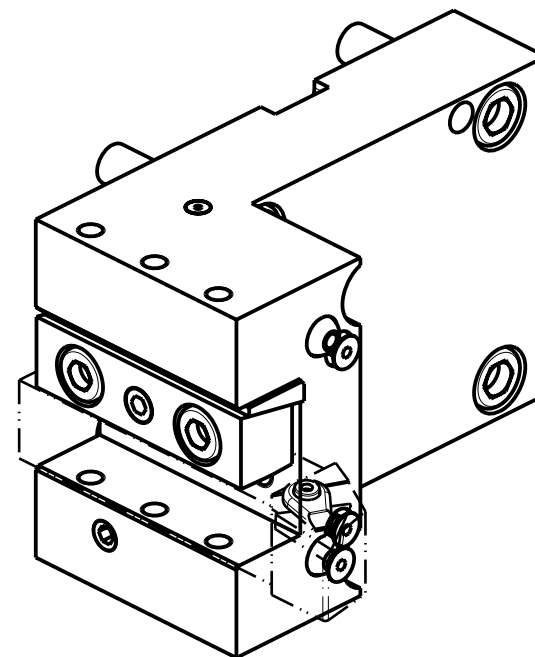
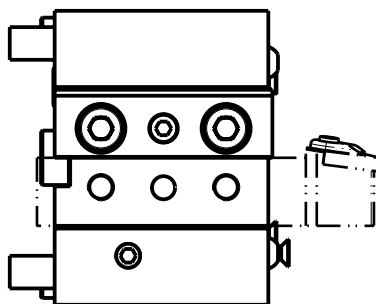
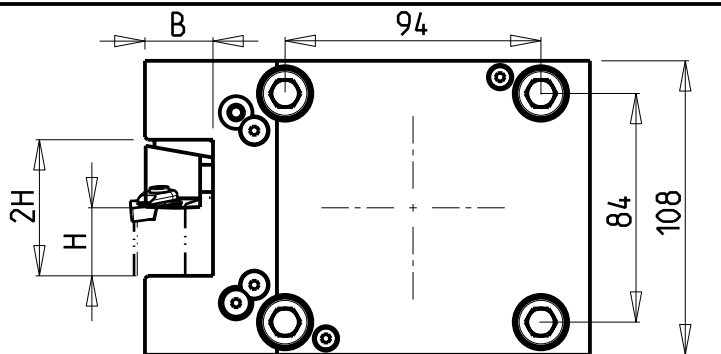

Cod. MT	N°Utensili N°Tools N°Werkzeuge	Reversibile lato mandrino/contromandrino Reversible sub/main spindle side Umkehrbare Spindelseite/ Gegenspindelseite	Misure Dimensions Masse	B	H
GDW 0072500	1/2	X	mm	25	25
GDW 0072540	1/2	X	Inch	1"	1"

GOODWAY
MOD: GS2600/2800

PORTAUTENSILE RADIALE SINGOLO
Radial single static tool
Radial Single-Werkzeughalter

M.T. srl

Via Casino Albini 480
Tel. 0541/956034-957884
Fax 0541/956341
47842 S. GIOVANNI IN M. (RN)
e-mail: mtma@mtmarchetti.com
http://www.mtmarchetti.com

PRODUZIONE MODULI ROTANTI



PAGINA GDW 423-1-00

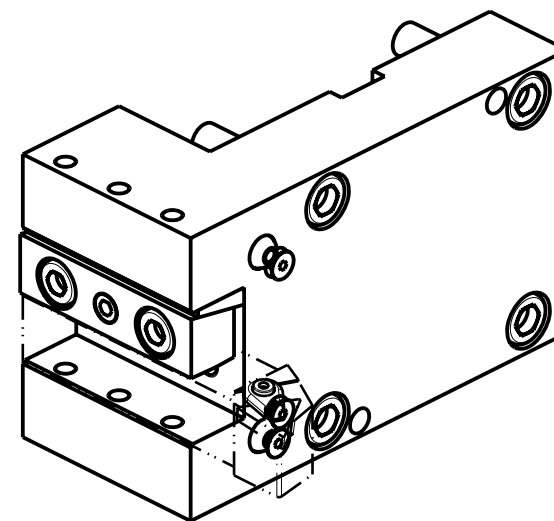
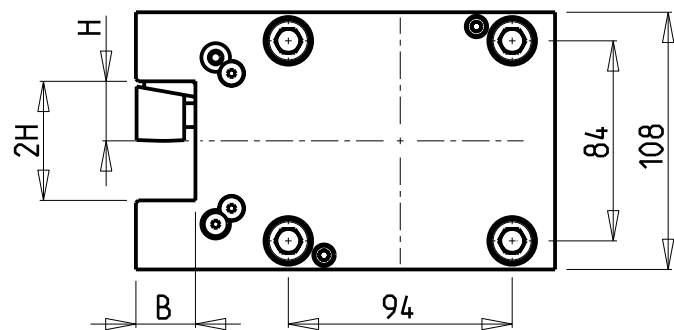
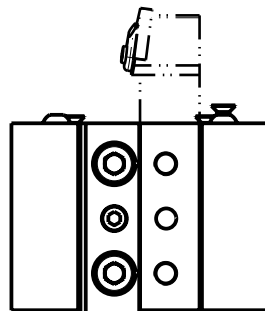
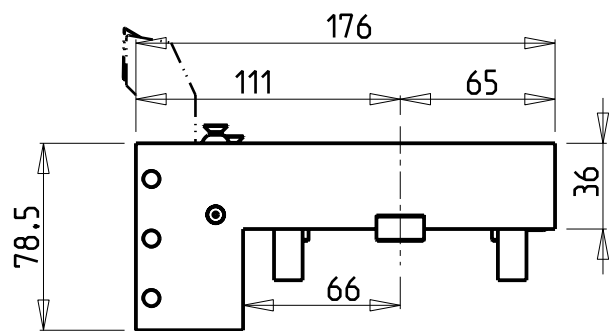

Cod. MT	N°Utensili N°Tools N°Werkzeuge	Misure Dimensions Masse	B	H
GDW 0262500	1/2	mm	25	25
GDW 0262540	1/2	Inch	1"	1"

GOODWAY
MOD: GS2600/2800

PORTAUTENSILE RADIALE SINGOLO ARRETRATO
Radial rear-set single static tool
Radial Single-Werkzeughalter zurueckversetzt

M.T. srl

Via Casino Albini 480
Tel. 0541/956034-957884
Fax 0541/956341
47842 S. GIOVANNI IN M. (RN)
e-mail: mtma@mtmarchetti.com
http://www.mtmarchetti.com

PRODUZIONE MODULI ROTANTI



PAGINA GDW 433-1-00

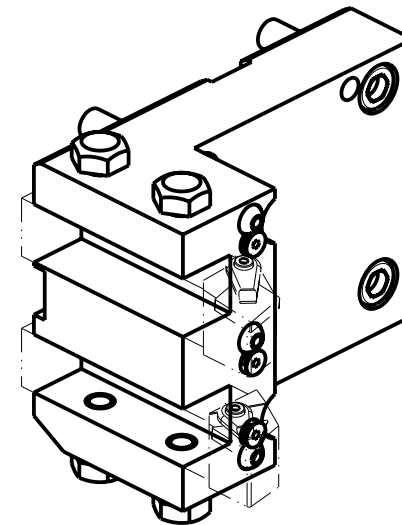
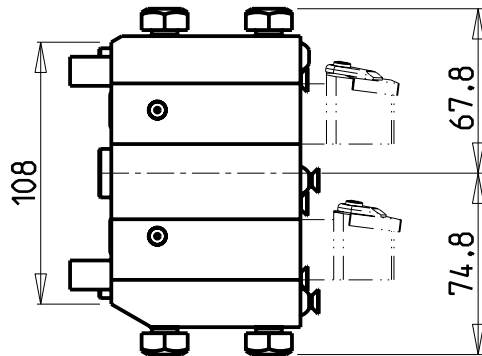
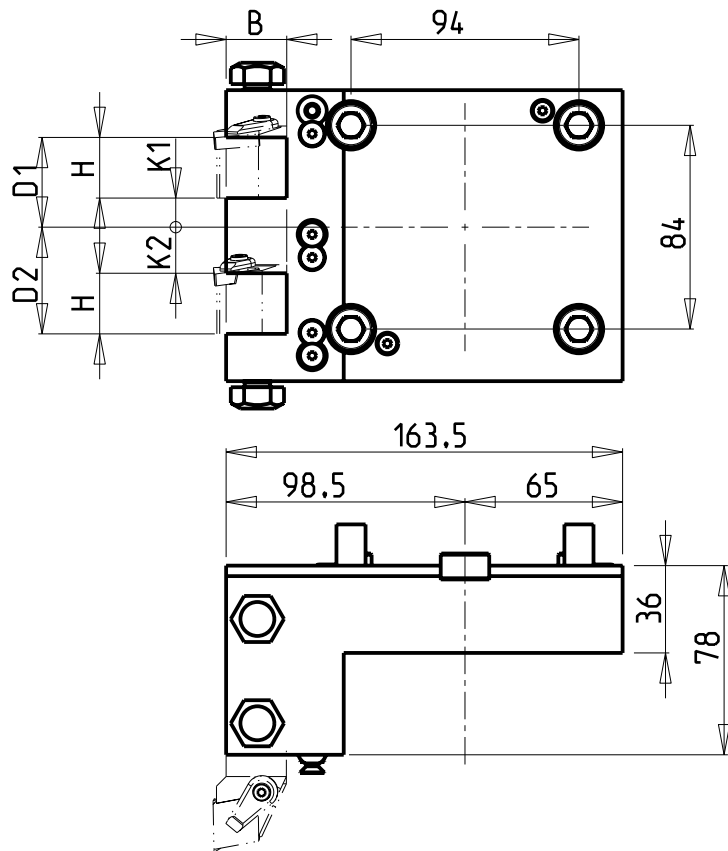

Cod. MT	N°Utensili N°Tools N°Werkzeuge	Reversibile lato mandrino/contromandrino Reversible sub/main spindle side Umkehrbare Spindel-seite/ Gegenspindel-seite	Misure Dimensions Masse	H	B	K1	K2	D1	D2
GDW 0092500	2	X	mm	25	25	12	19	37	44
GDW 0092540	2	X	Inch	1"	1"	1/2"	3/4"	1 1/2"	1 3/4"

GOODWAY
 MOD: GS2600/2800
 PORTAUTENSILE RADIALE SOVRAPPOSTO
 Radial single side twin static tool
 Radial Werkzeughalter ueberlagert

M.T. srl
 Via Casino Albini 480
 Tel. 0541/956034-957884
 Fax 0541/956341
 47842 S. GIOVANNI IN M. (RN)
 e-mail: mtma@mtmarchetti.com
 http://www.mtmarchetti.com

PRODUZIONE MODULI ROTANTI



PAGINA GDW 442-1-00

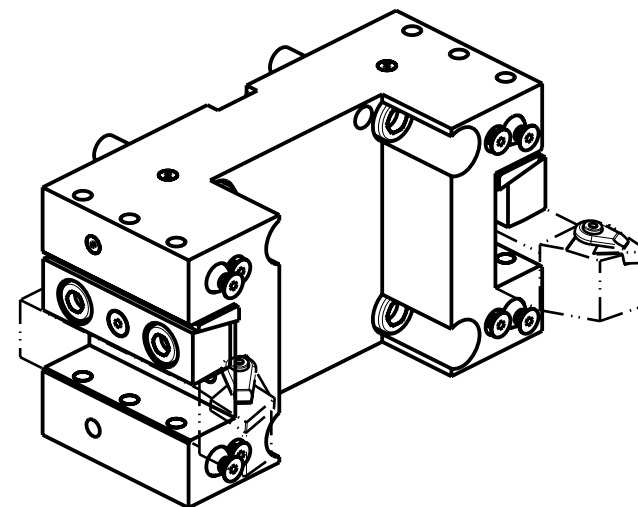
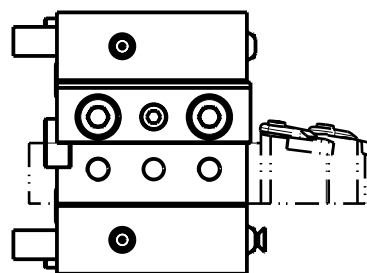
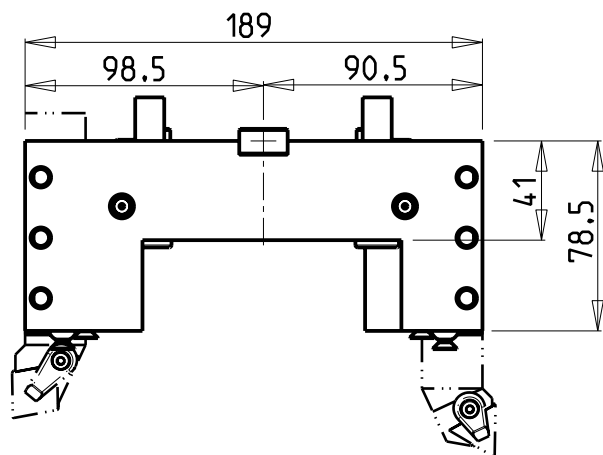
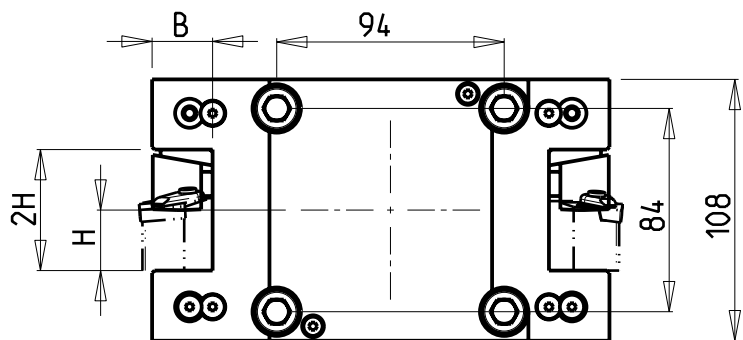

Cod. MT	N°Utensili N°Tools N°Werkzeuge	Reversibile lato mandrino/contromandrino Reversible sub/main spindle side Umkehrbare Spindel-seite/ Gegenspindel-seite	Misure Dimensions Masse	B	H
GDW 0082500	2/4	X	mm	25	25
GDW 0082540	2/4	X	Inch	1"	1"

GOODWAY
MOD: GS2600/2800

PORTAUTENSILE RADIALE DOPPIO
Radial double static tool
Radial Doppel-Werkzeughalter

M.T. srl

Via Casino Albini 480
Tel. 0541/956034-957884
Fax 0541/956341
47842 S. GIOVANNI IN M. (RN)
e-mail: mtma@mtmarchetti.com
<http://www.mtmarchetti.com>

PRODUZIONE MODULI ROTANTI



PAGINA GDW 453-1-00

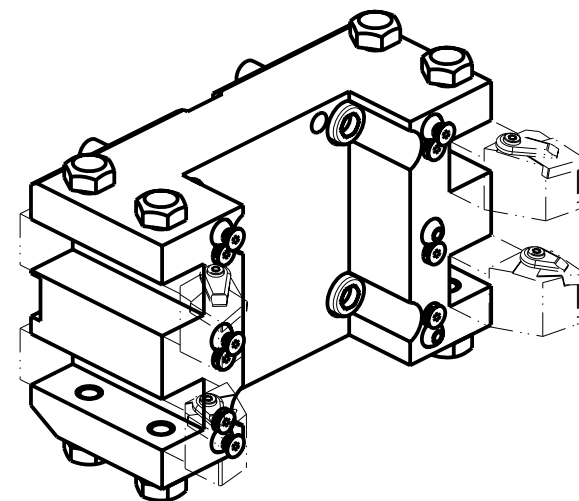
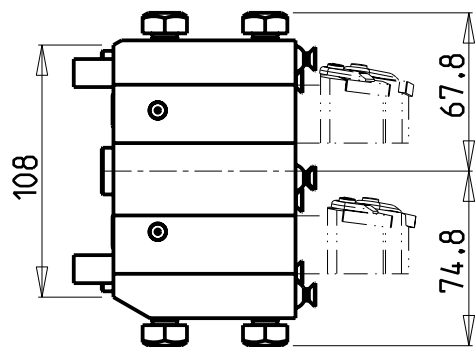
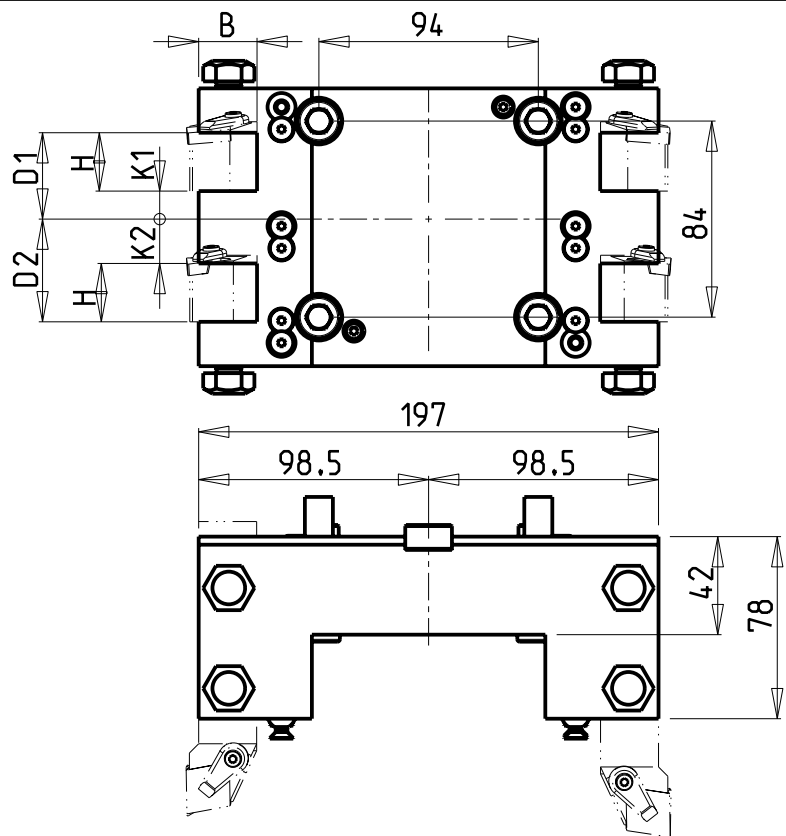

Cod. MT	N°Utensili N°Tools N°Werkzeuge	Reversibile lato mandrino/contromandrino Reversible sub/main spindle side Umkehrbare Spindel-seite/ Gegenspindel-seite	Misure Dimensions Masse	H	B	K1	K2	D1	D2
GDW 0102500	4	X	mm	25	25	12	19	37	44
GDW 0102540	4	X	Inch	1"	1"	1/2"	3/4"	1 1/2"	1 3/4"

GOODWAY
 MOD: GS2600/2800
 PORTAUTENSILE RADIALE DOPPIO SOVRAPPOSTO
 Radial double side twin static tool
 Radial Doppel-Werkzeughalter ueberlagert

M.T. srl
 Via Casino Albini 480
 Tel. 0541/956034-957884
 Fax 0541/956341
 47842 S. GIOVANNI IN M. (RN)
 e-mail: mtma@mtmarchetti.com
 http://www.mtmarchetti.com

PRODUZIONE MODULI ROTANTI



PAGINA GDW 463-1-00

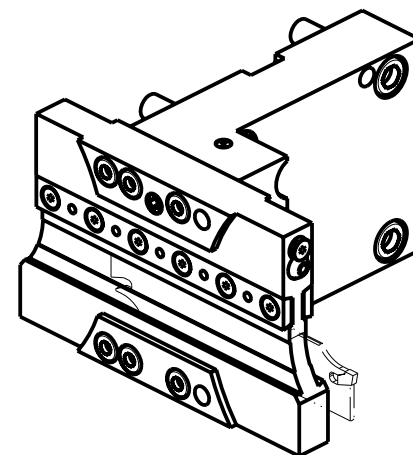
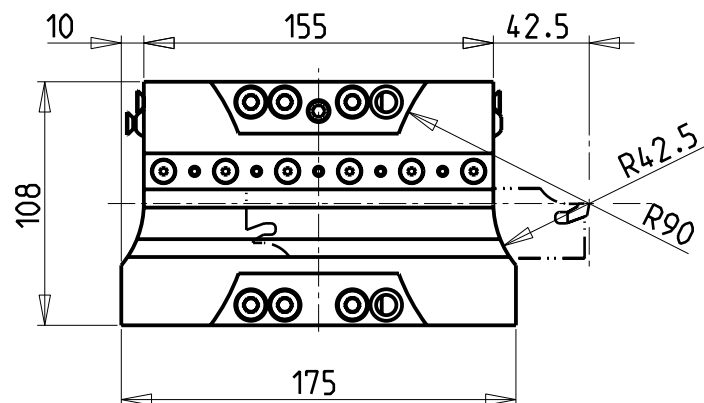
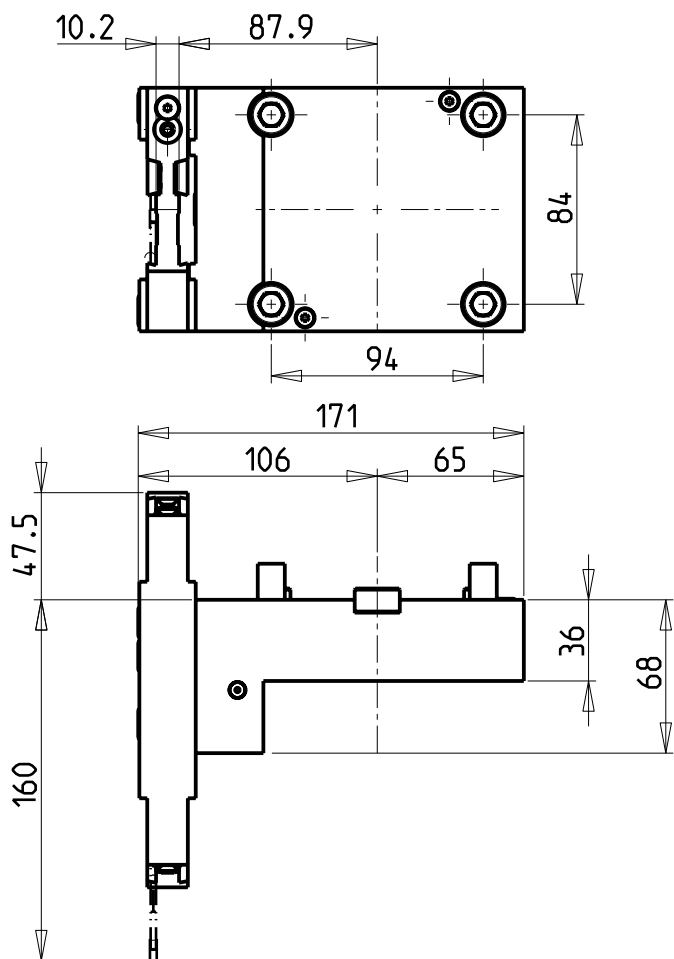

POSSIBILITA' DI LAVORO M3/M4
 OPTION OF M3/M4 WORKING
 ARBEITSMÖGLICHKEIT M3/M4

DOTAZIONI - SUPPLIED WITH - AUSSTATTUNG

N°1 - LAMA - BLADE - KLINGE ISCAR H=32 Sp. 3/4mm
 (KENNAMETAL OPTIONAL)

N°10 - INSERTI - INSERTS - EINLAGEN

N°1 - CHIAVE A T PER MONTAGGIO INSERTI
 - T-WRENCH FOR INSERT SET UP
 - T-SCHLUESSEL FUER EINSATZSTUECK-MONTAGE

Cod. MT

N°Utensili
 N°Tools
 N°Werkzeuge

GDW 0130132

1

GOODWAY
 MOD: GS2600/2800

PORTAUTENSILE PER LAMA DOPPIO
 Radial double blade holder
 Radial Doppel-Abstechhalter

M.T. srl

Via Casino Albini 480
 Tel. 0541/956034-957884
 Fax 0541/956341
 47842 S. GIOVANNI IN M. (RN)
 e-mail: mtma@mtmarchetti.com
 http://www.mtmarchetti.com

PRODUZIONE MODULI ROTANTI



PAGINA GDW 520-1-00

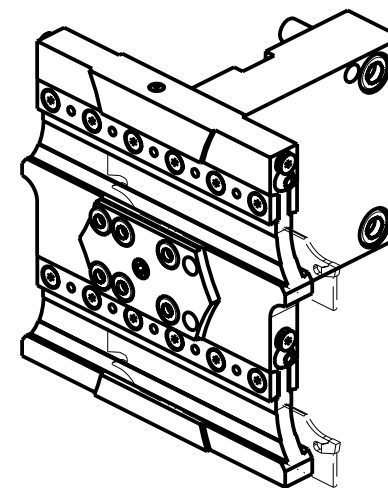
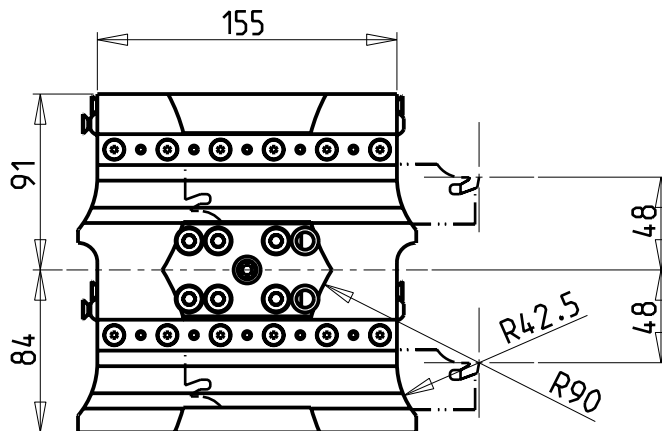
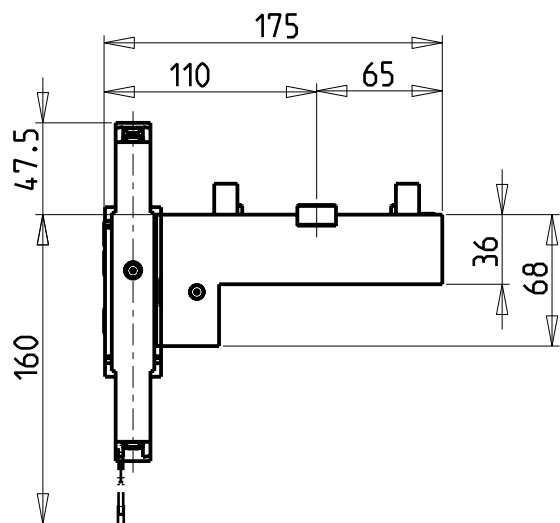
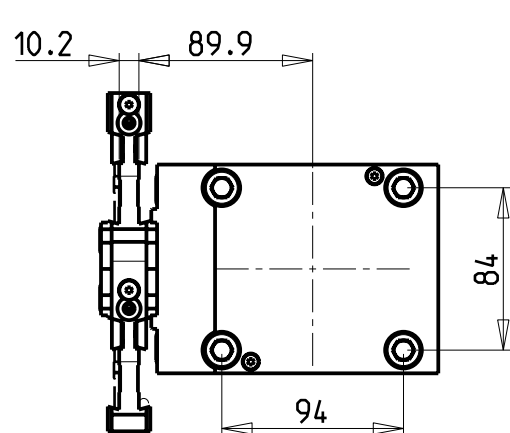

POSSIBILITA' DI LAVORO M3/M4
 OPTION OF M3/M4 WORKING
 ARBEITSMOGLICHKEIT M3/M4

SOLO PER MACCHINE CON ASSE Y
 ONLY FOR Y-AXIS MACHINES
 NUR FUR MASCHINEN MIT ACHSE Y

DOTAZIONI - SUPPLIED WITH - AUSSTATTUNG

- N°1 - LAMA - BLADE - KLINGE ISCAR H=32 Sp. 3/4mm (KENNAMETAL OPTIONAL)
- N°10 - INSERTI - INSERTS - EINLAGEN
- N°1 - CHIAVE A T PER MONTAGGIO INSERTI
 - T-WRENCH FOR INSERT SET UP
 - T-SCHLUESSEL FUER EINSATZSTUECK-MONTAGE

Cod. MT

N°Utensili
 N°Tools
 N°Werkzeuge

GDW 0270232

2

GOODWAY
 MOD: GS2600/2800

PORTAUTENSILE PER LAMA DOPPIO E SOVRAPPOSTO
 Radial double twin-side blade holder
 Radial Doppel-Abstechhalter ueberlagert

M.T. srl

Via Casino Albini 480
 Tel. 0541/956034-957884
 Fax 0541/956341
 47842 S. GIOVANNI IN M. (RN)
 e-mail: mtma@mtmarchetti.com
 http://www.mtmarchetti.com

PRODUZIONE MODULI ROTANTI



PAGINA GDW 525-1-00

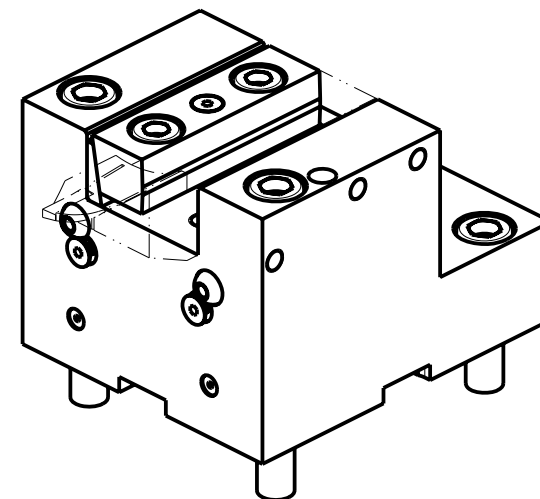
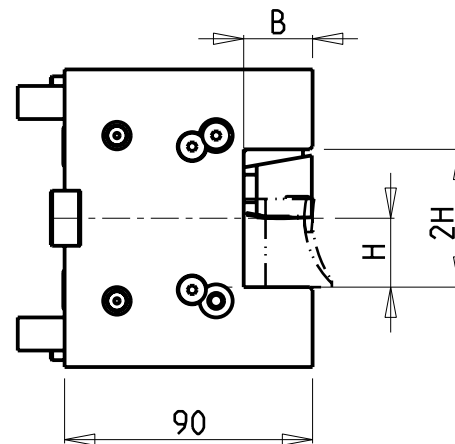
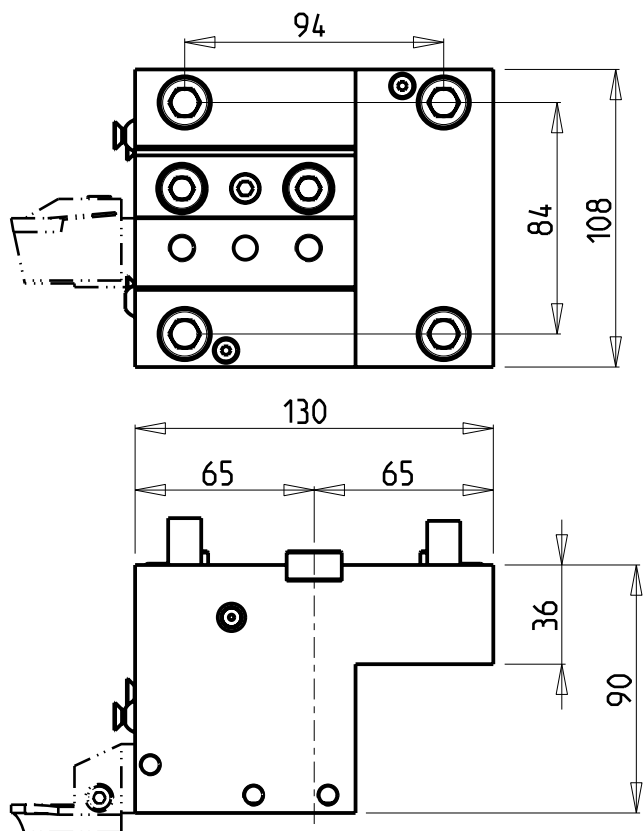

Cod. MT	N°Utensili N°Tools N°Werkzeuge	Reversibile lato mandrino/contromandrino Reversible sub/main spindle side Umkehrbare Spindelseite/ Gegenspindelseite	Misure Dimensions Masse	B	H
GDW 0112500	1/2	X	mm	25	25
GDW 0112540	1/2	X	Inch	1"	1"

GOODWAY
MOD: GS2600/2800

PORTAUTENSILE ASSIALE SINGOLO
Axial single static tool
Axial Single-Werkzeughalter

M.T. srl

Via Casino Albini 480
Tel. 0541/956034-957884
Fax 0541/956341
47842 S. GIOVANNI IN M. (RN)
e-mail: mtma@mtmarchetti.com
http://www.mtmarchetti.com

PRODUZIONE MODULI ROTANTI



PAGINA GDW 552-1-00

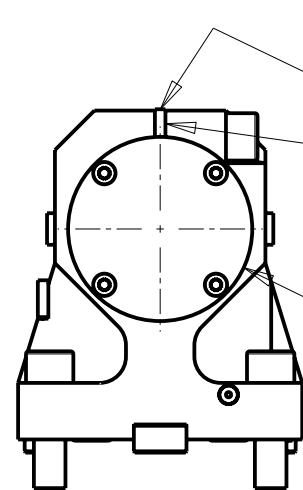
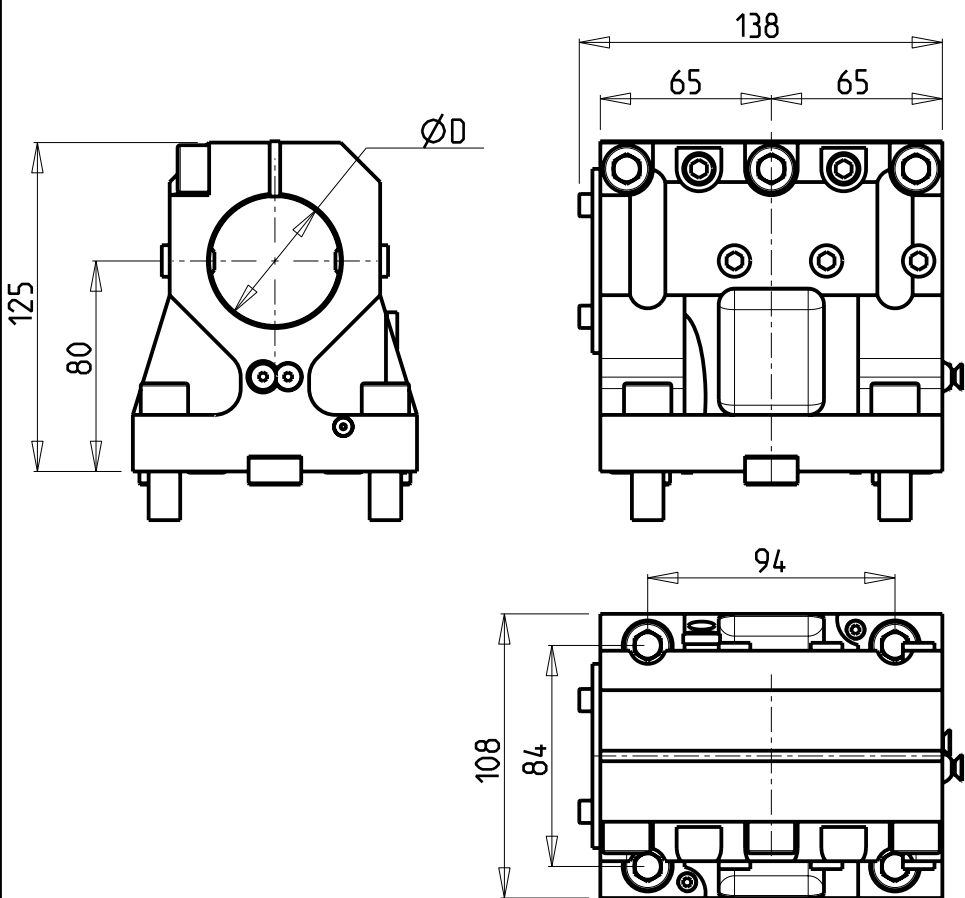

SOLO GUARNIZIONE (OPZIONALE)
 ONLY SEAL (OPTIONAL)
 NUR DICHTUNG (OPTIONAL)
 cod. MNL0110008

KIT ADDUZIONE INTERNA (OPZIONALE)
 KIT FOR INTERNAL COOLANT (OPTIONAL)
 KIT FUER INTERNE KUEHLMITTELZUFUHR (OPTIONAL)
 Ø50-Ø2" cod. KIT1001002

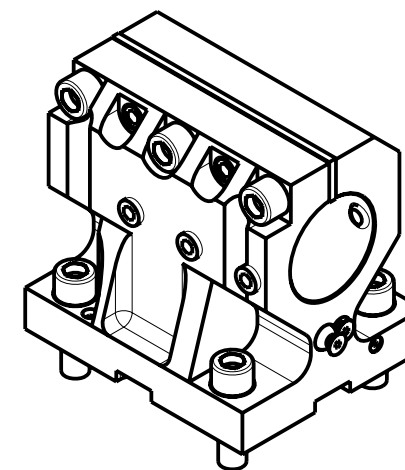

Cod. MT	N°Utensili N°Tools N°Werkzeuge	Reversibile lato mandrino/contromandrino Reversible sub/main spindle side Umkehrbare Spindel-seite/ Gegenspindel-seite	Lubrificazione int. opzionale Coolant through optional Innenkuhlung Optional	Lubrificazione est. Ext. coolant Aussenkuhlung	Misure Dimensions Masse	D
GDW 0125000	1	X	X	X	mm	50
GDW 0125080	1	X	X	X	Inch	2"

PER BOCCOLE DI RIDUZIONE VEDI PAG. TBL150-1-00
 FOR REDUCING BUSHINGS SEE PAGE TBL150-1-00
 FÜR REDUZIERBUCHSE SIEHE SEITE TBL150-1-00

GOODWAY
 MOD: GS2600/2800

PORTAUTENSILE ASSIALE PER BARENO Ø50mm / Ø2" H=80mm
 Axial single boring bar holder Ø50mm / Ø2" H=80mm
 Axial Bohrhälter Ø50mm / Ø2" H=80mm

M.T. srl

Via Casino Albini 480
 Tel. 0541/956034-957884
 Fax 0541/956341
 47842 S. GIOVANNI IN M. (RN)
 e-mail: mtma@mtmarchetti.com
 http://www.mtmarchetti.com

PRODUZIONE MODULI ROTANTI



PAGINA GDW 610-1-20

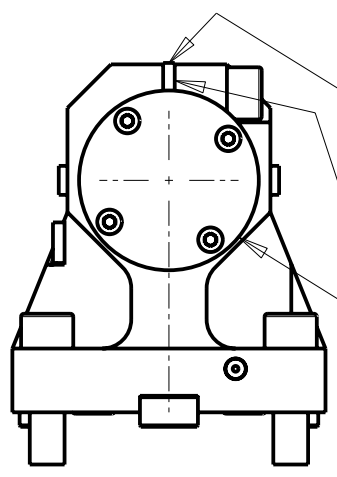
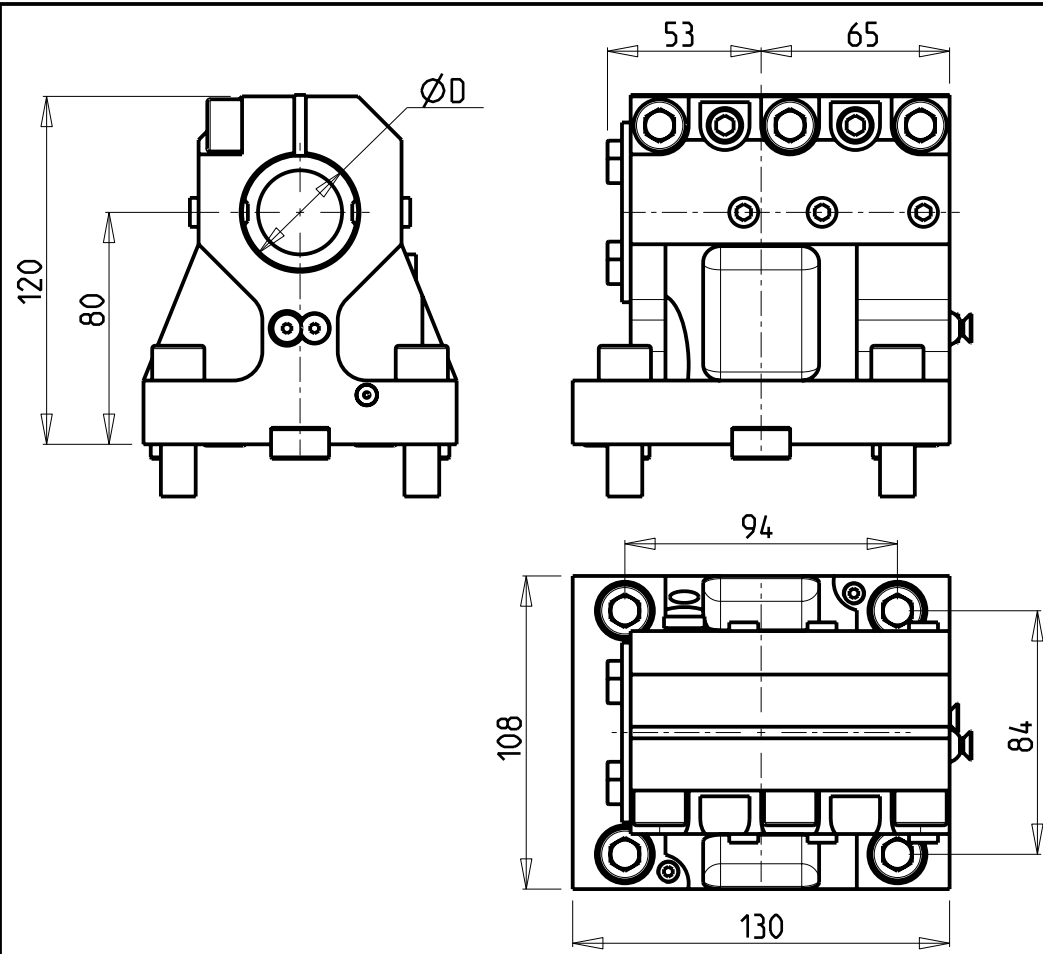

SOLO GUARNIZIONE (OPZIONALE)
 ONLY SEAL (OPTIONAL)
 NUR DICHTUNG (OPTIONAL)
 cod. 0520013

KIT ADDUZIONE INTERNA (OPZIONALE)
 KIT FOR INTERNAL COOLANT (OPTIONAL)
 KIT FUER INTERNE KUEHLMITTELZUFUHR (OPTIONAL)
 Ø40 cod. KIT1003003
 Ø1 1/2" cod. KIT1003004

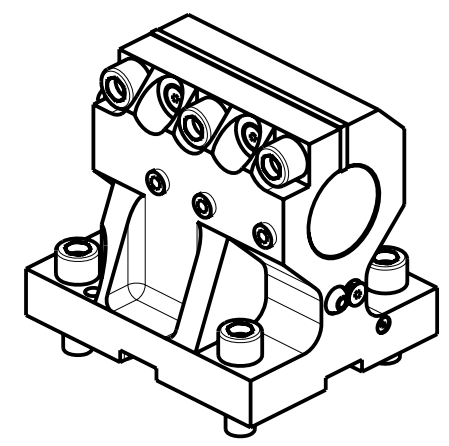

Cod. MT	N°Utensili N°Tools N°Werkzeuge	Reversibile lato mandrino/contromandrino Reversible sub/main spindle side Umkehrbare Spindel-seite/ Gegenspindel-seite	Lubrificazione int. opzionale Coolant through optional Innenkuhlung Optional	Lubrificazione est. Ext. coolant Aussenkuhlung	Misure Dimensions Masse	D.
GDW 0124000	1	X	X	X	mm	40
GDW 0123810	1	X	X	X	Inch	1 1/2"

PER BOCCOLE DI RIDUZIONE VEDI PAG. TBL150-1-00
 FOR REDUCING BUSHINGS SEE PAGE TBL150-1-00
 FÜR REDUZIERBUCHSE SIEHE SEITE TBL150-1-00

GOODWAY
 MOD: GS2600/2800
 PORTAUTENSILE ASSIALE PER BARENO Ø40mm / Ø1 1/2" H=80mm
 Axial single boring bar holder Ø40mm / Ø1 1/2" H=80mm
 Axial Bohrhälter Ø40mm / Ø1 1/2" H=80mm



M.T. srl
 Via Casino Albini 480
 Tel. 0541/956034-957884
 Fax 0541/956341
 47842 S. GIOVANNI IN M. (RN)
 e-mail: mtma@mtmarchetti.com
 http://www.mtmarchetti.com

PRODUZIONE MODULI ROTANTI

PAGINA GDW 630-1-20

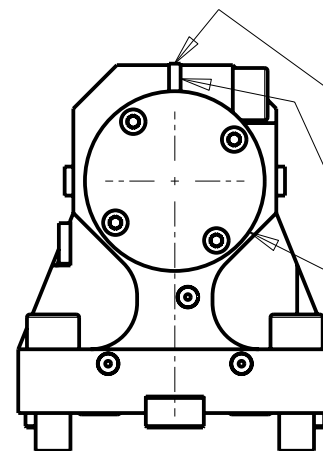
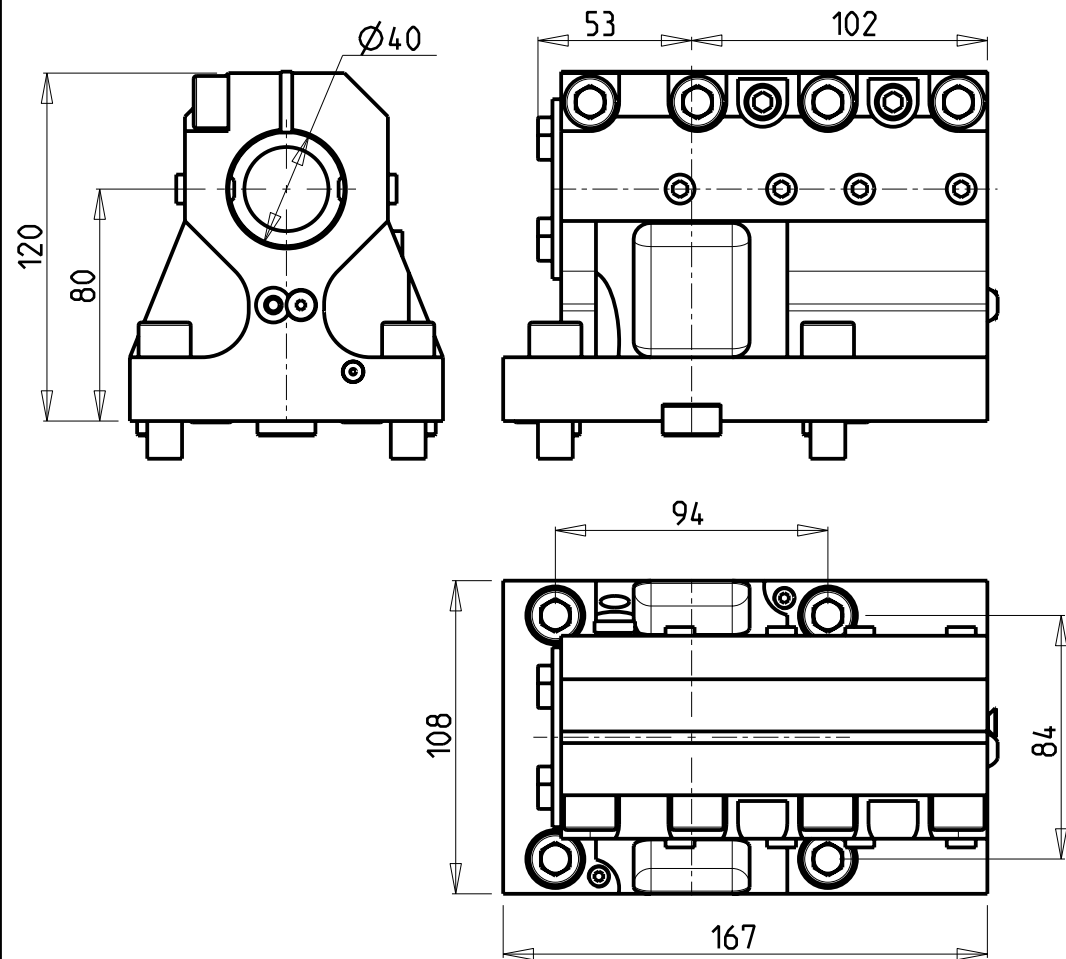

SOLO GUARNIZIONE (OPZIONALE)
 ONLY SEAL (OPTIONAL)
 NUR DICHTUNG (OPTIONAL)
 cod. MNLO310005

KIT ADDUZIONE INTERNA (OPZIONALE)
 KIT FOR INTERNAL COOLANT (OPTIONAL)
 KIT FUER INTERNE KUEHLMITTELZUFUHR (OPTIONAL)
 Ø40 cod. KIT1002003

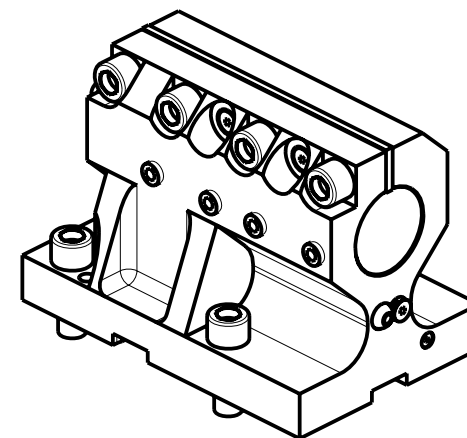

Cod. MT	N°Utensili N°Tools N°Werkzeuge	Reversibile lato mandrino/contromandrino Reversible sub/main spindle side Umkehrbare Spindel-seite/ Gegenspindel-seite	Lubrificazione int. opzionale Coolant through optional Innenkühlung Optional	Lubrificazione est. Ext. coolant Aussenkühlung
GDW 0284000	1	X	X	X

PER BOCCOLE DI RIDUZIONE VEDI PAG. TBL150-1-00
 FOR REDUCING BUSHINGS SEE PAGE TBL150-1-00
 FÜR REDUZIERBUCHSE SIEHE SEITE TBL150-1-00

GOODWAY
 MOD: GS2600/2800

PORTAUTENSILE ASSIALE PROLUNGATO PER BARENO Ø40mm H=80mm
 Axial single extended boring bar holder Ø40mm H=80mm
 Axial Bohrhälter verlaengert Ø40mm H=80mm

M.T. srl

Via Casino Albini 480
 Tel. 0541/956034-957884
 Fax 0541/956341
 47842 S. GIOVANNI IN M. (RN)
 e-mail: mtma@mtmarchetti.com
 http://www.mtmarchetti.com

PRODUZIONE MODULI ROTANTI



PAGINA GDW 760-1-20

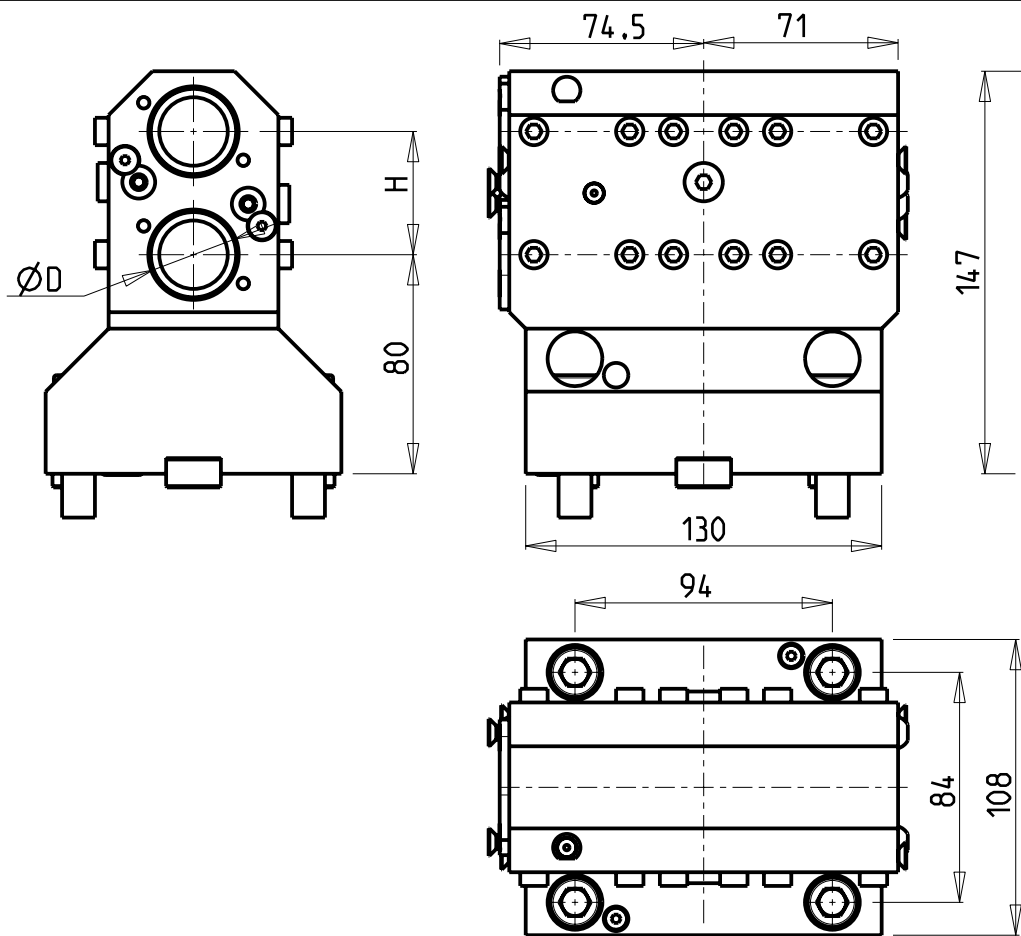

KIT ADDUZIONE INTERNA (OPZIONALE)
 KIT FOR INTERNAL COOLANT (OPTIONAL)
 KIT FUER INTERNE KUEHLMITTELZUFUHR (OPTIONAL)
 cod. KIT1000001

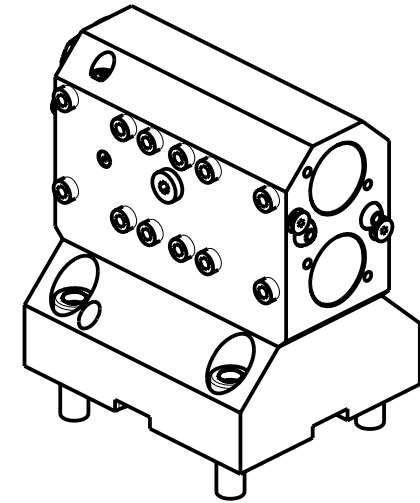

PER BOCCOLE DI RIDUZIONE VEDI PAG. TBL150-1-00
 FOR REDUCING BUSHINGS SEE PAGE TBL150-1-00
 FUR REDUZIERBUCHSE SIEHE SEITE TBL150-1-00

Cod. MT	N°Utensili N°Tools N°Werkzeuge	Lubrificazione int. opzionale Coolant through optional Innenkuehlung Optional	Lubrificazione est. Ext. coolant Aussenkuehlung	Misure Dimensions Masse	D	H
GDW 0293200	2+2	X	X	mm	32	45
GDW 0293175	2+2	X	X	Inch	1 1/4"	1 3/4"

GOODWAY
 MOD: GS2600/2800

PORTAUTENSILE ASSIALE PER BARENO 2+2 POSIZIONI Ø32mm / Ø1 1/4"
 Axial 2+2 position upright boring bar holder Ø32mm / Ø1 1/4"
 Axial Bohrhalter 2+2 Positionen Ø32mm / Ø1 1/4"

M.T. srl

Via Casino Albini 480
 Tel. 0541/956034-957884
 Fax 0541/956341
 47842 S. GIOVANNI IN M. (RN)
 e-mail: mtma@mtmarchetti.com
 http://www.mtmarchetti.com

PRODUZIONE MODULI ROTANTI



PAGINA GDW 872-1-00

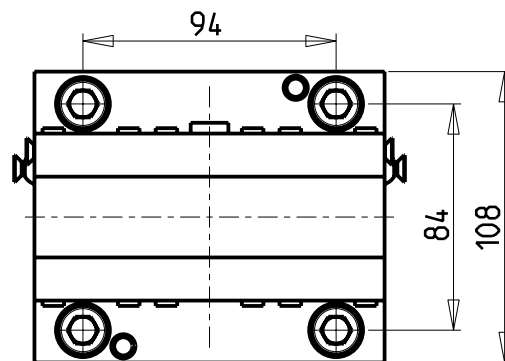
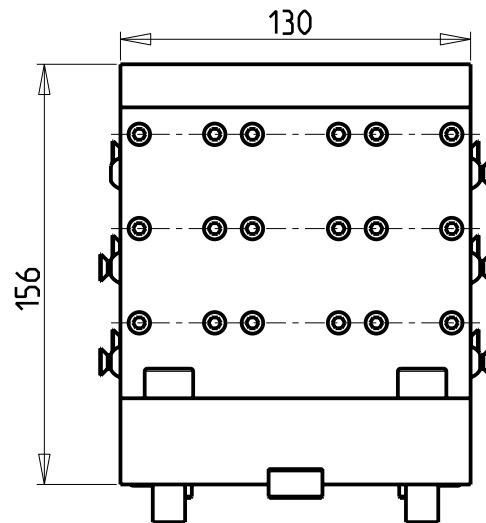
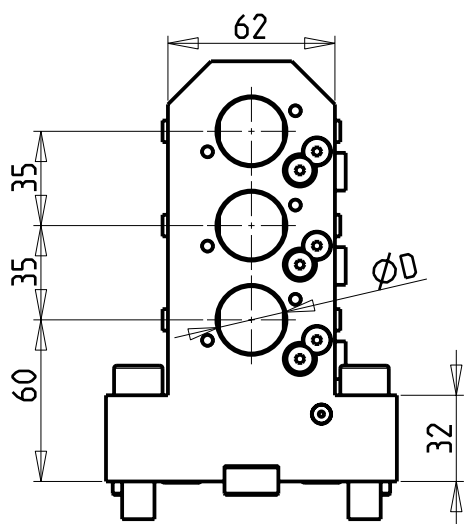

KIT ADDUZIONE INTERNA (OPZIONALE)
 KIT FOR INTERNAL COOLANT (OPTIONAL)
 KIT FUER INTERNE KUEHLMITTELZUFUHR (OPTIONAL)
 cod. KIT1000006

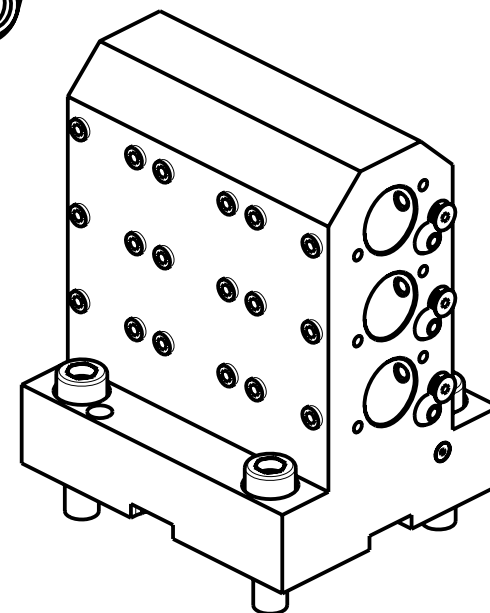

PER BOCCOLE DI RIDUZIONE VEDI PAG. TBL150-1-00
 FOR REDUCING BUSHINGS SEE PAGE TBL150-1-00
 FÜR REDUZIERBUCHSE SIEHE SEITE TBL150-1-00

Cod. MT	N°Utensili N°Tools N°Werkzeuge	Lubrificazione int. opzionale Coolant through optional Innenkuehlung Optional	Lubrificazione est. Ext. coolant Aussenkuehlung	D
GDW 0302500	3+3	X	X	25
GDW 0302540	3+3	X	X	1"

GOODWAY
 MOD: GS2600/2800

PORTAUTENSILE ASSIALE PER BARENO 3+3 POSIZIONI SOVRAPPOSTE Ø25mm / Ø1"
 Axial 3+3 position upright boring bar holder Ø25mm / Ø1"
 Axial Bohrhälter 3+3 Positionen ueberlagert Ø25mm / Ø1"

M.T. srl

Via Casino Albini 480
 Tel. 0541/956034-957884
 Fax 0541/956341
 47842 S. GIOVANNI IN M. (RN)
 e-mail: mtma@mtmarchetti.com
 http://www.mtmarchetti.com

PRODUZIONE MODULI ROTANTI



PAGINA GDW 894-1-00

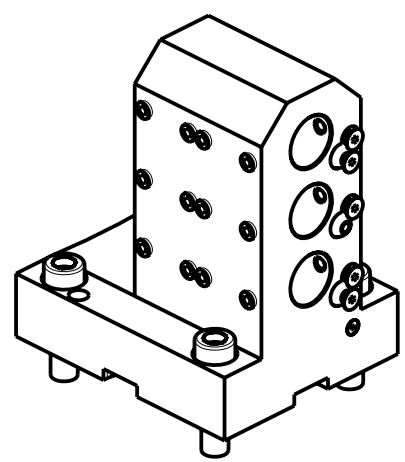
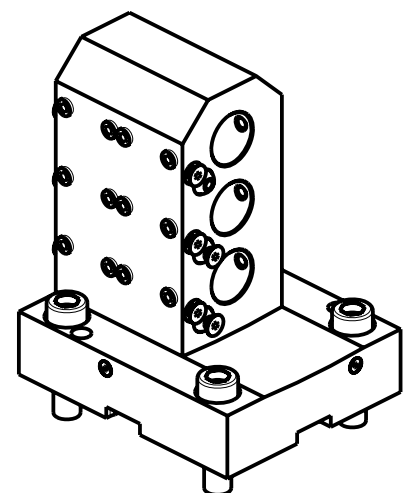
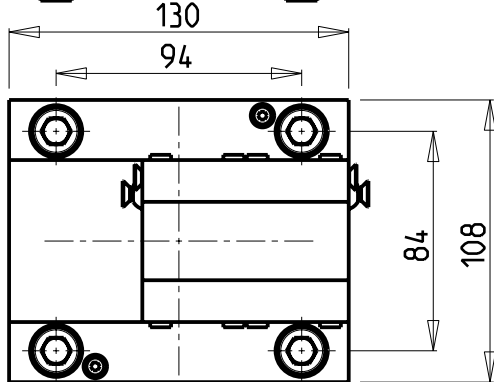
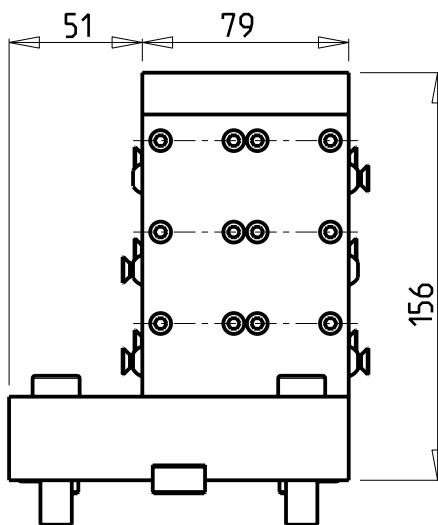
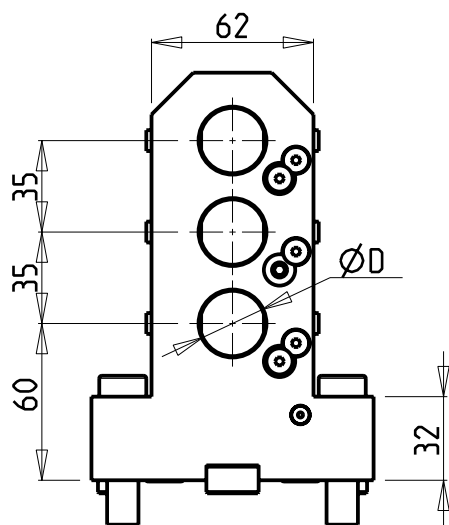

PER BOCCOLE DI RIDUZIONE VEDI PAG. TBL150-1-00
 FOR REDUCING BUSHINGS SEE PAGE TBL150-1-00
 FÜR REDUZIERBUCHSE SIEHE SEITE TBL150-1-00

Cod. MT	N°Utensili N°Tools N°Werkzeuge	Reversibile lato mandrino/contromandrino Reversible sub/main spindle side Umkehrbare Spindel-seite/ Gegenspindel-seite	Lubrificazione est. Ext. coolant Aussenkuehlung	D
GDW 0312500	3	X	X	25
GDW 0312540	3	X	X	1"

GOODWAY
 MOD: GS2600/2800

PORTAUTENSILE ASSIALE ARRETRATO PER BARENO 3 POSIZIONI SOVRAPPOSTE Ø25mm / Ø1"
 Axial 3 position upright rear set boring bar holder Ø25mm / Ø1"
 Axial Bohrhälter 3 Positionen zurueckversetzt ueberlagert Ø25mm / Ø1"

M.T. srl
 Via Casino Albini 480
 Tel. 0541/956034-957884
 Fax 0541/956341
 47842 S. GIOVANNI IN M. (RN)
 e-mail: mtma@mtmarchetti.com
 http://www.mtmarchetti.com

PRODUZIONE MODULI ROTANTI

PAGINA GDW 904-1-00

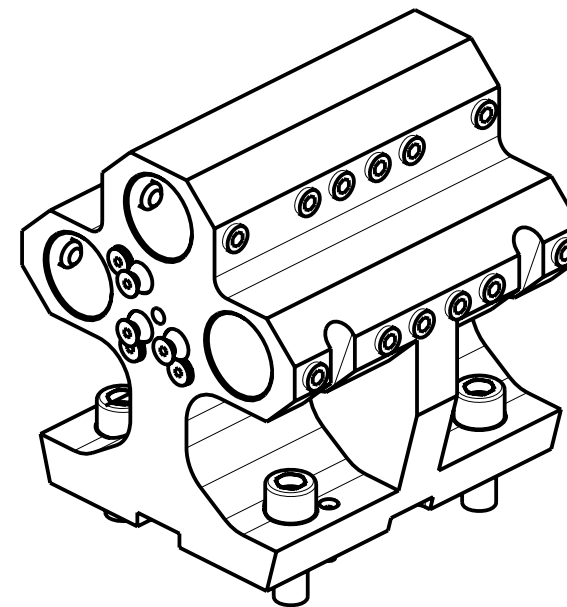
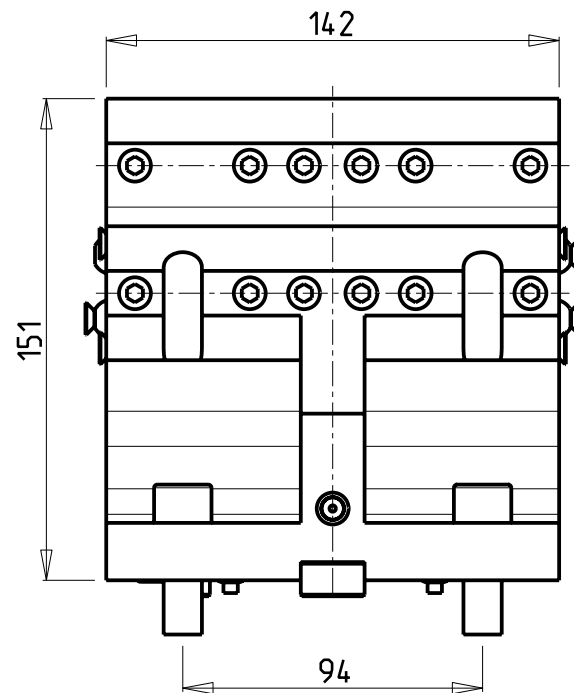
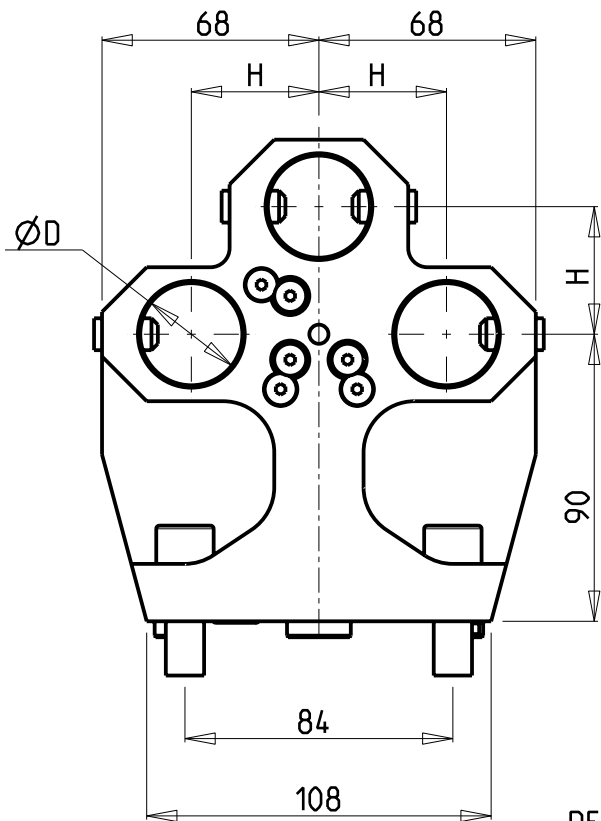

PER BOCCOLE DI RIDUZIONE VEDI PAG. TBL150-1-00
 FOR REDUCING BUSHINGS SEE PAGE TBL150-1-00
 FÜR REDUZIERBUCHSE SIEHE SEITE TBL150-1-00

Cod. MT	N°Utensili N°Tools N°Werkzeuge	Lubrificazione int. Coolant through Innenkuehlung	Lubrificazione est. Ext. coolant Aussenkuehlung	Misure Dimensions Masse	D	H
GDW 0323200	3+3	X	X	mm	32	40
GDW 0323175	3+3	X	X	Inch	1 1/4"	1 1/2"

GOODWAY
 MOD: GS2600/2800

PORTAUTENSILE ASSIALE PER BARENO 3+3 POSIZIONI Ø32mm / Ø1 1/4"
 Axial 3+3 position boring bar holder Ø32mm / Ø1 1/4"
 Axial Bohrhälter 3+3 Positionen Ø32mm / Ø1 1/4"

M.T. srl

Via Casino Albini 480
 Tel. 0541/956034-957884
 Fax 0541/956341
 47842 S. GIOVANNI IN M. (RN)
 e-mail: mtma@mtmarchetti.com
 http://www.mtmarchetti.com

PRODUZIONE MODULI ROTANTI



PAGINA GDW 912-1-00

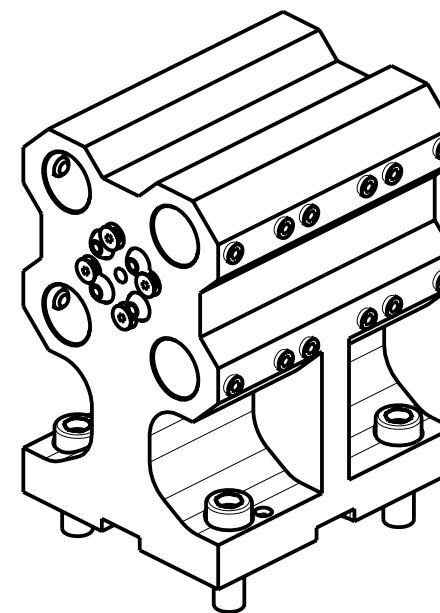
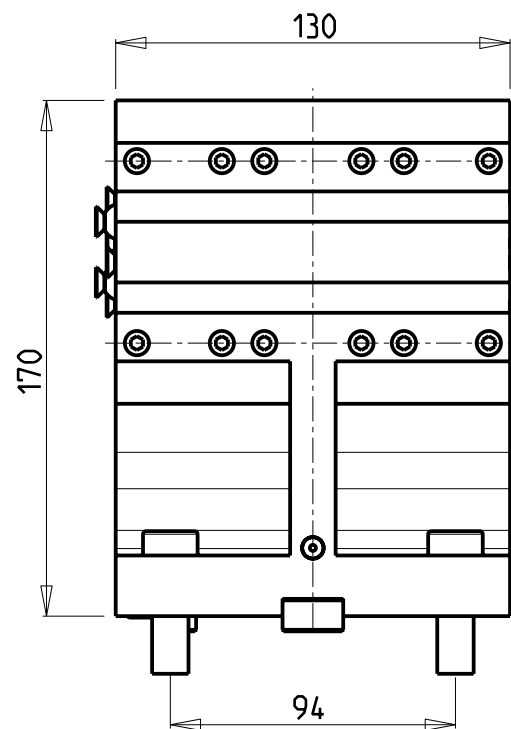
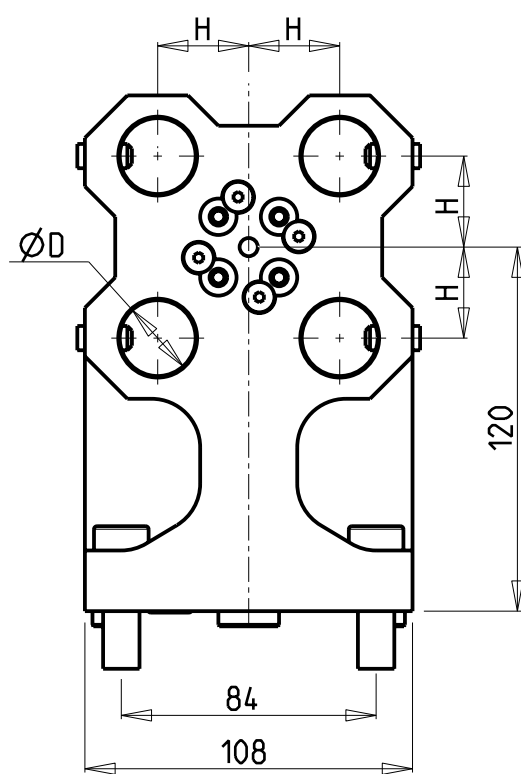

PER BOCCOLE DI RIDUZIONE VEDI PAG. TBL150-1-00
 FOR REDUCING BUSHINGS SEE PAGE TBL150-1-00
 FÜR REDUZIERBUCHSE SIEHE SEITE TBL150-1-00

Cod. MT	N°Utensili N°Tools N°Werkzeuge	Lubrificazione est. Ext. coolant Aussenkuehlung	Misure Dimensions Masse	D	H
GDW 0332500	4+4	X	mm	25	30
GDW 0332540	4+4	X	Inch	1"	1 1/4"

GOODWAY
 MOD: GS2600/2800

PORTAUTENSILE ASSIALE PER BARENO 4+4 POSIZIONI Ø25mm / Ø1"
 Axial 4+4 position boring bar holder Ø25mm / Ø1"
 Axial Bohrhälter 4+4 Positionen Ø25mm / Ø1"

M.T. srl

Via Casino Albini 480
 Tel. 0541/956034-957884
 Fax 0541/956341
 47842 S. GIOVANNI IN M. (RN)
 e-mail: mtma@mtmarchetti.com
 http://www.mtmarchetti.com

PRODUZIONE MODULI ROTANTI



PAGINA GDW 922-1-00

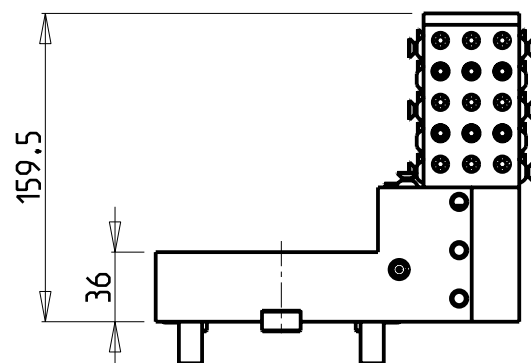
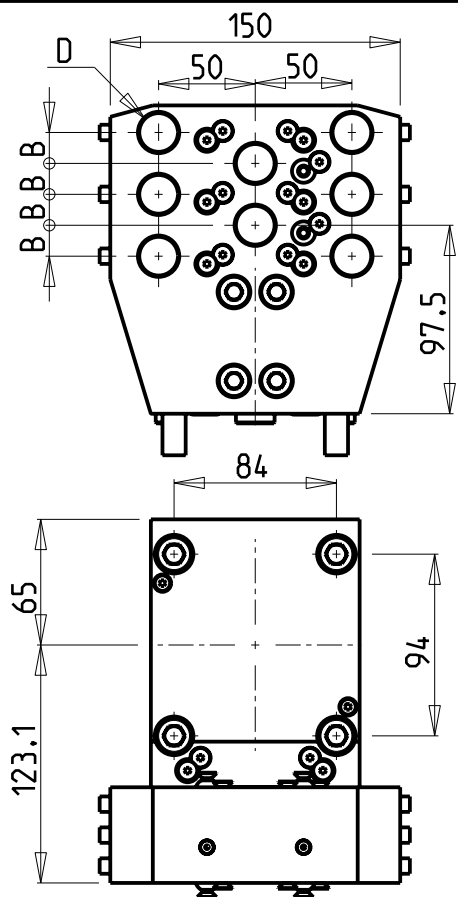

DOTAZIONI - SUPPLIED WITH - AUSSTATTUNG

mm	N°5 Boccole - Bushings - Buchsen Ø16-12-10-8-6 N°1 ER16 Portapinza - Collet holder - Zangenhalter N°1 ER25 Portapinza - Collet holder - Zangenhalter
inch	N°3 Boccole - Bushings - Buchsen Ø1/2"-3/8"-1/4" N°1 ER16 Portapinza - Collet holder - Zangenhalter N°1 ER25 Portapinza - Collet holder - Zangenhalter

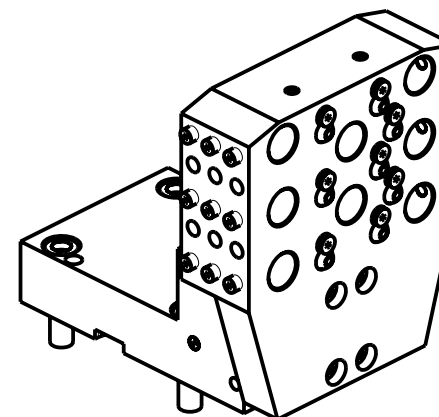

Cod. MT	N°Utensili N°Tools N°Werkzeuge	Reversibile lato mandrino/contromandrino Reversible sub/main spindle side Umkehrbare Spindel-seite/ Gegenspindel-seite	Lubrificazione est. Exl. coolant Aussenkuehlung	Misure Dimensions Masse	D	B	H
GDW 0342000	8	X	X	mm	20	16	50
GDW 0341905	8	X	X	Inch	3/4"	5/8"	2"

GOODWAY
MOD: GS2600/2800

PORTAUTENSILE ASSIALE PER BARENO 8 POSIZIONI Ø20mm / Ø3/4"
Axial 8 position boring bar holder Ø20mm / Ø3/4"
Axial Bohrhälter 8 Positionen Ø20mm / Ø3/4"

M.T. srl

Via Casino Albini 480
Tel. 0541/956034-957884
Fax 0541/956341
47842 S. GIOVANNI IN M. (RN)
e-mail: mtma@mtmarchetti.com
http://www.mtmarchetti.com

PRODUZIONE MODULI ROTANTI



PAGINA GDW 933-1-00

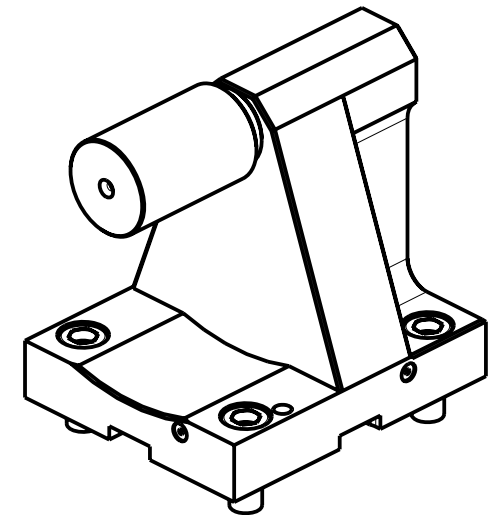
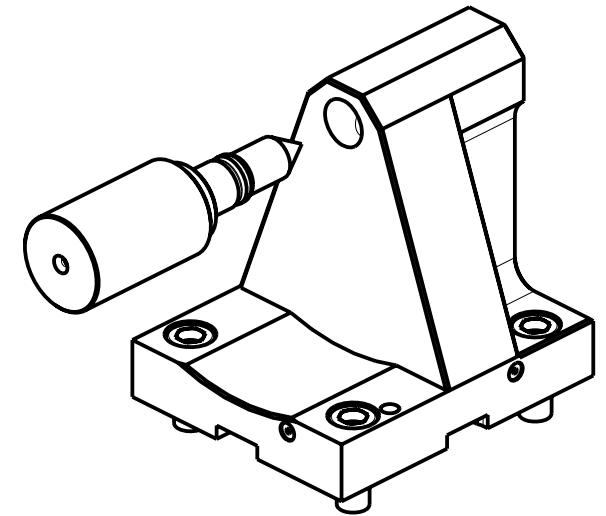
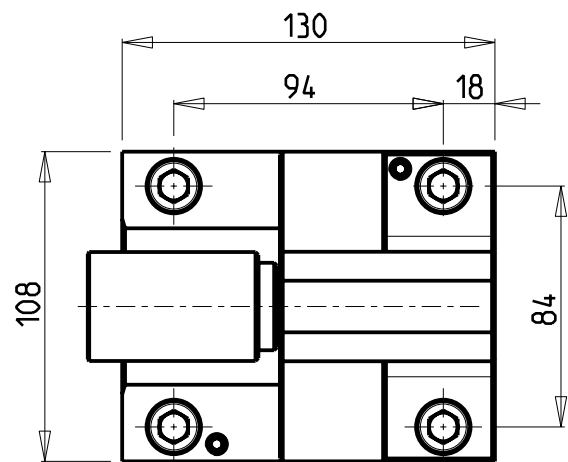
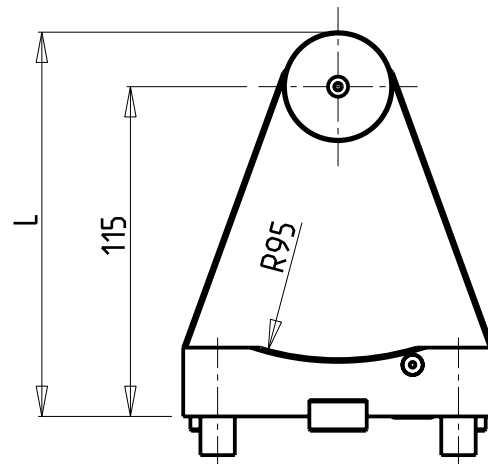
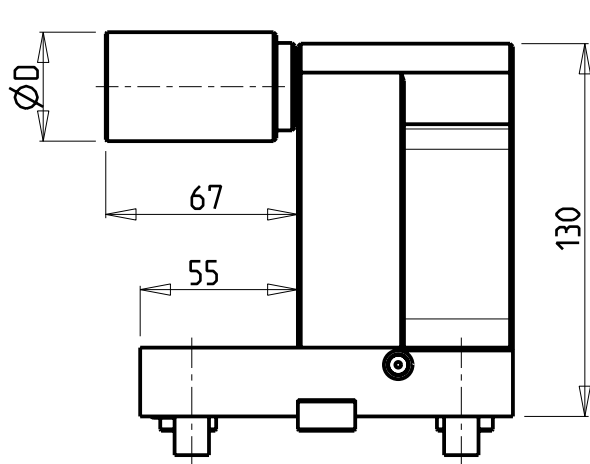

Cod. MT	N°Utensili N°Tools N°Werkzeuge	D	L
GDW 0350100	1	38	134
GDW 0350100L	1	2"	140.4

GOODWAY
MOD: GS2600/2800

CONTROPUNTA PER CONTROMANDRINO
Tailstock for subspindle
Gegenspitz fuer Gegenspindel

M.T. srl

Via Casino Albini 480
Tel. 0541/956034-957884
Fax 0541/956341
47842 S. GIOVANNI IN M. (RN)
e-mail: mtma@mtmarchetti.com
http://www.mtmarchetti.com

PRODUZIONE MODULI ROTANTI



PAGINA GDW 950-1-00

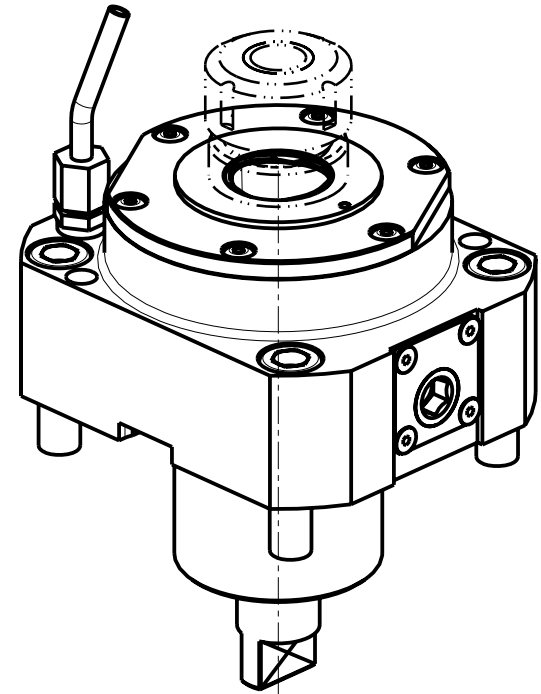
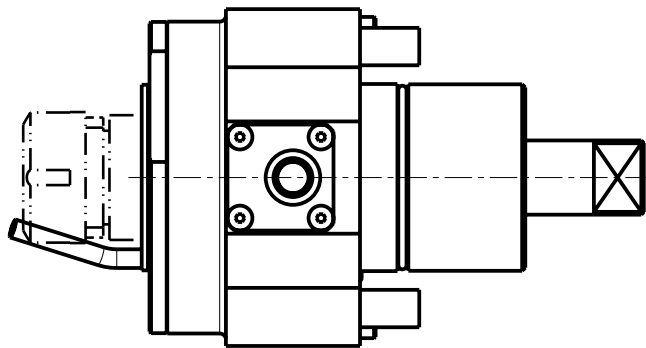
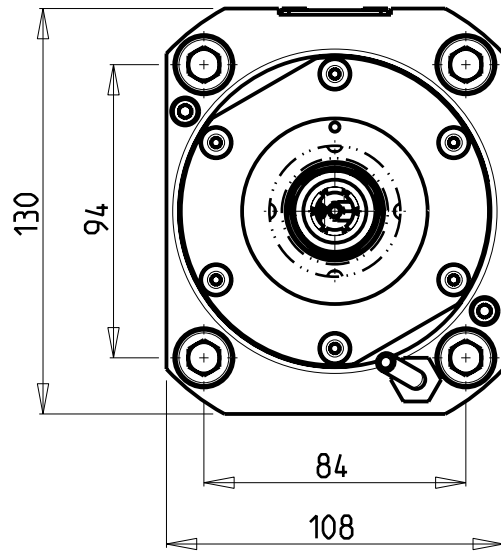
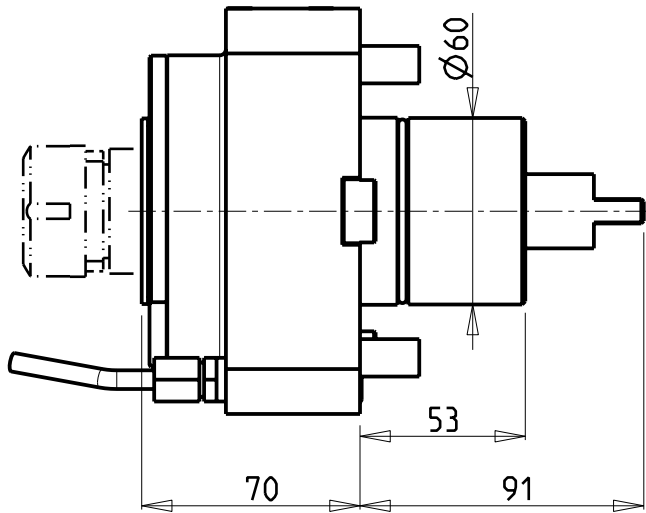

Cod. MT	TAGLIA Size Masse	I	RPM	Coppia Max Max Torque Max Drehmoment	Lubr.esterna Ext. coolant Aussenkuehlung
GDW 0370140	C4	1:1	6000	70Nm	X
GDW 0370150	C5	1:1	6000	70Nm	X

GOODWAY
MOD: GS2600/2800

MODULO MOTORIZZATO RADIALE COROMANT CAPTO®
Radial driven tool COROMANT CAPTO®
Radial angetriebenes Werkzeug COROMANT CAPTO®

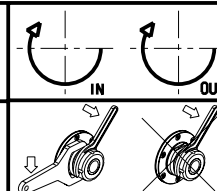

M.T. srl
Via Casino Albini 480
Tel. 0541/956034-957884
Fax 0541/956341
47842 S. GIOVANNI IN M. (RN)
e-mail: mtma@mtmarchetti.com
http://www.mtmarchetti.com

PRODUZIONE MODULI ROTANTI



PAGINA GDW 010-A-40

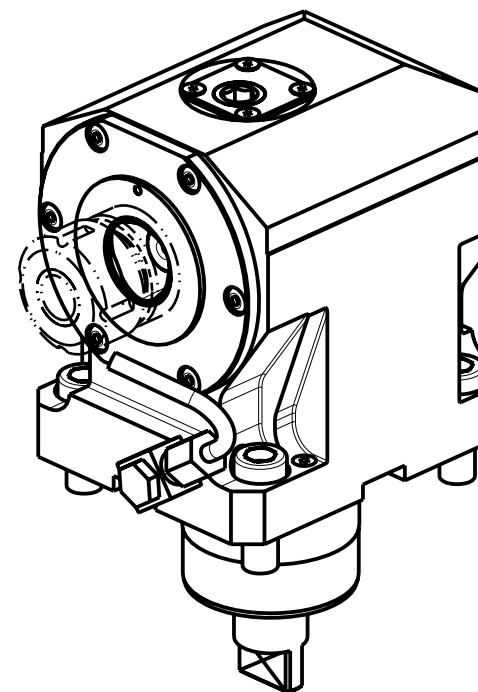
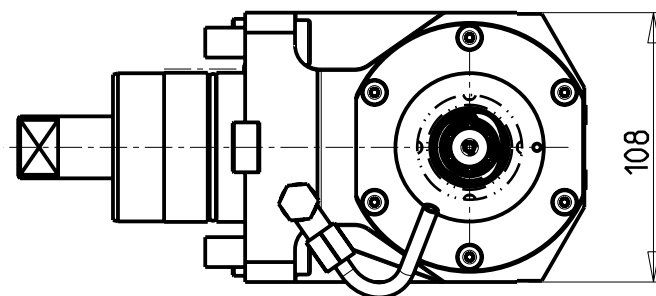
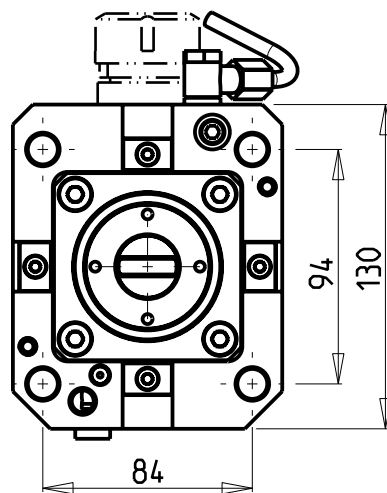
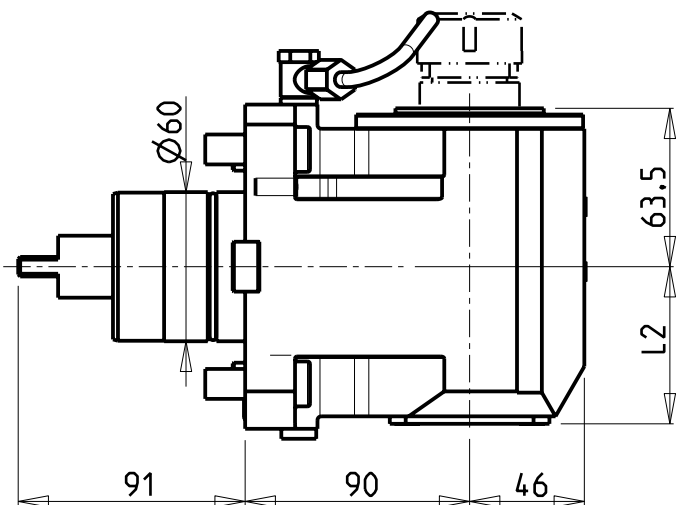

Cod. MT	TAGLIA Size Masse	I	RPM	Coppia Max Max Torque Max Drehmoment	Reversibile lato mandrino/contromandrino Reversible sub/main spindle side Umkehrbare Spindel-seite/ Gegenspindel-seite	Lubr.interna Coolant through Innenkuehlung	Lubr.esterna Ext. coolant Aussenkuehlung	L2
GDW 0360140	C4	1:1	6000	70Nm	X		X	63
GDW 0360240	C4	1:1	6000	70Nm	X	P=70bar	X	76.5
GDW 0360150	C5	1:1	6000	70Nm	X		X	63
GDW 0360250	C5	1:1	6000	70Nm	X	P=70bar	X	76.5

GOODWAY
MOD: GS2600/2800

MODULO MOTORIZZATO ASSIALE COROMANT CAPTO®
Axial driven tool COROMANT CAPTO®
Axial angetriebenes Werkzeug COROMANT CAPTO®

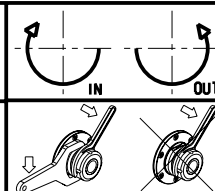

M.T. srl

Via Casino Albini 480
Tel. 0541/956034-957884
Fax 0541/956341

47842 S. GIOVANNI IN M. (RN)
e-mail: mtma@mtmarchetti.com
http://www.mtmarchetti.com

PRODUZIONE MODULI ROTANTI



PAGINA GDW 150-A-40

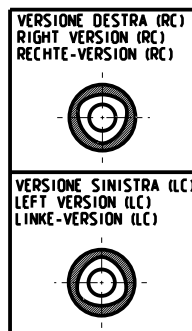
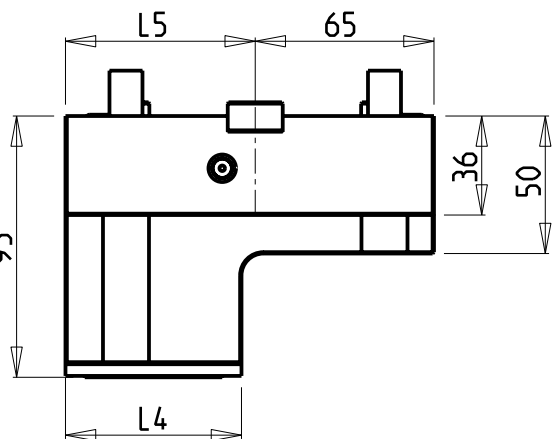
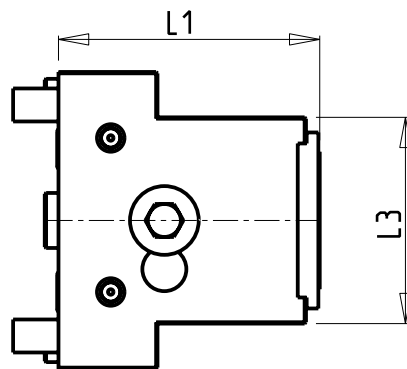
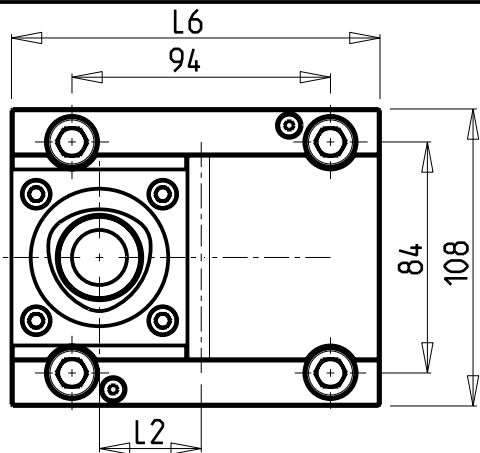

PER ORDINARE LA VERSIONE SX
AGGIUNGERE "LC" AL CODICE IN TABELLA.
ES: MNL0464010 DIVENTA MNL0464010LC

TO ORDER LEFT VERSION
ADD A "LC" IN THE CODE-CHARTS.
EXAMPLE: MNL0464010 BECOMES MNL0464010LC

UM DIE LINKE-VERSION ZU BESTELLEN, BEI DER
ARTIKELBEZEICHNUNG "LC" HINZUFUEGEN.
BEISPIEL: MNL0464010 WIRD DANN MNL0464010LC

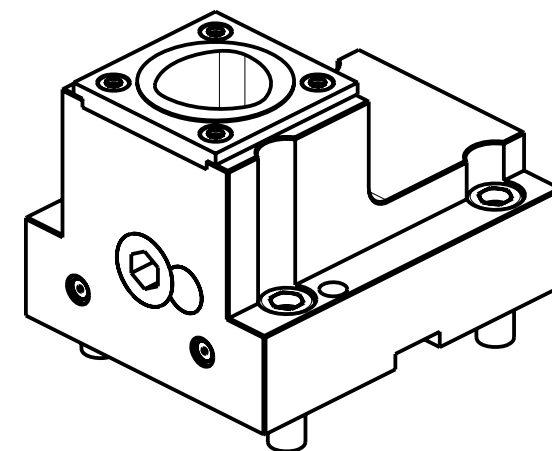

Cod. MT	N°Utensili N°Tools N°Werkzeuge	Lubrificazione int. Coolant through Innenkuehlung	Reversibile lato mandrino/contromandrino Reversible sub/main spindle side Umkehrbare Spindelseite/ Gegenspindelseite	TAGLIA Size Masse	L1	L2	L3	L4	L5	L6
GDW 0384010	1	X	X	C4	90	45	63	48	69	134
GDW 0385010	1	X	X	C5	95	37	75	64	69	134
GDW 0385015	1	X	X	C5	95	62.5	75	64	94.5	159.5

GOODWAY
MOD: GS2600/2800

PORTAUTENSILE RADIALE SINGOLO COROMANT CAPTO®
Radial single static tool COROMANT CAPTO®
Radial Single-Werkzeughalter COROMANT CAPTO®

M.T. srl

Via Casino Albini 480
Tel. 0541/956034-957884
Fax 0541/956341
47842 S. GIOVANNI IN M. (RN)
e-mail: mtma@mtmarchetti.com
http://www.mtmarchetti.com

PRODUZIONE MODULI ROTANTI



PAGINA GDW 420-A-40

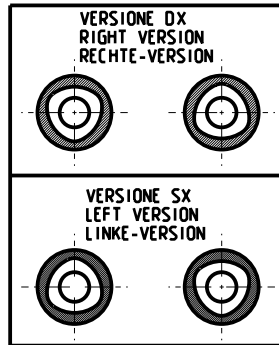
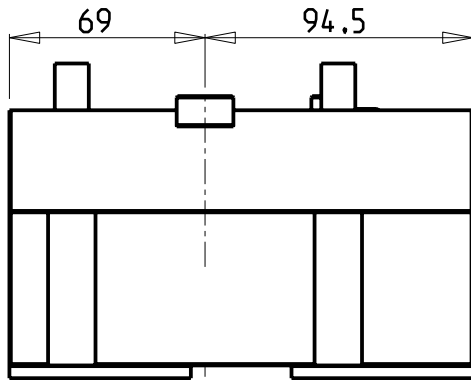
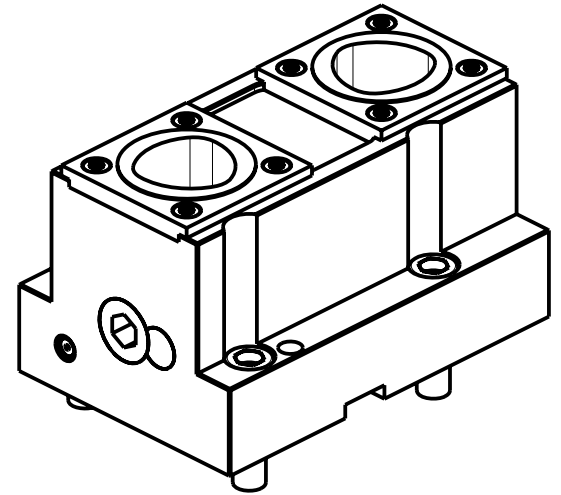
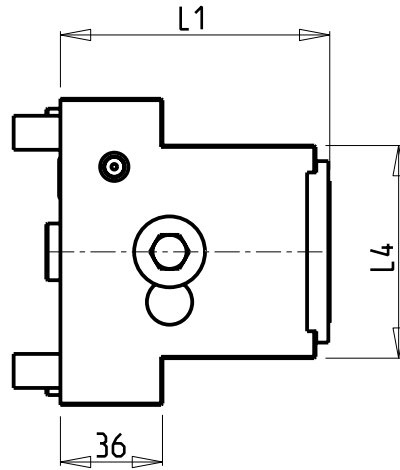
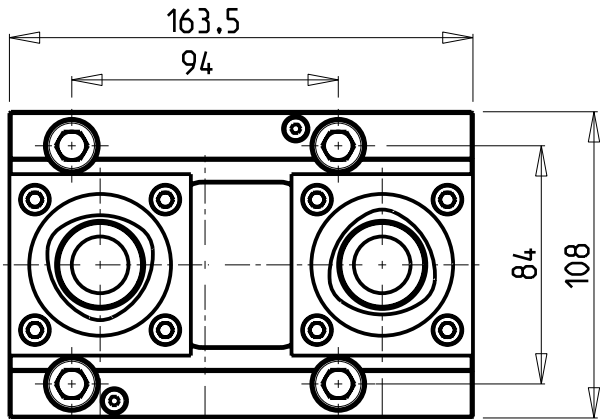

PER ORDINARE LA VERSIONE SX
AGGIUNGERE "LC" AL CODICE IN TABELLA.
ES: MNL0464010 DIVENTA MNL0464010LC

TO ORDER LEFT VERSION
ADD A "LC" IN THE CODE-CHARTS.
EXAMPLE: MNL0464010 BECOMES MNL0464010LC

UM DIE LINKE-VERSION ZU BESTELLEN, BEI DER
ARTIKELBEZEICHNUNG "LC" HINZUFUEGEN.
BEISPIEL: MNL0464010 WIRD DANN MNL0464010LC

Cod. MT	N°Utensili N°Tools N°Werkzeuge	Lubrificazione int. Coolant through Innenkuehlung	TAGLIA Size Masse	L1	L2	L3	L4
GDW 0394020	2	X	C4	90	45	70.5	63
GDW 0395020	2	X	C5	95	37	62.5	75

GOODWAY
MOD: GS2600/2800

PORTAUTENSILE RADIALE DOPPIO COROMANT CAPTO®
Radial double static tool COROMANT CAPTO®
Radial Doppel-Werkzeughalter COROMANT CAPTO®

M.T. srl

Via Casino Albini 480
Tel. 0541/956034-957884
Fax 0541/956341
47842 S. GIOVANNI IN M. (RN)
e-mail: mtma@mtmarchetti.com
http://www.mtmarchetti.com

PRODUZIONE MODULI ROTANTI



PAGINA GDW 450-A-40

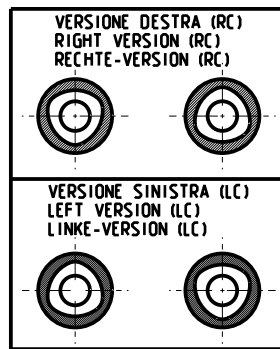
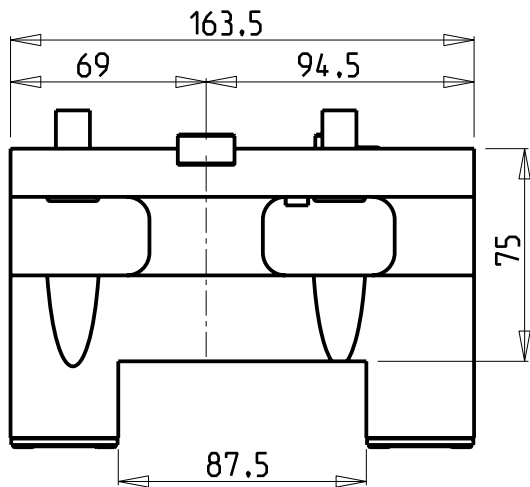
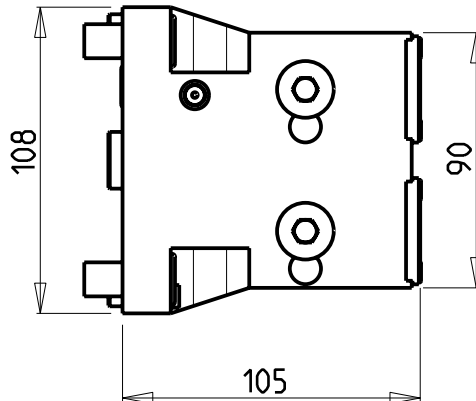
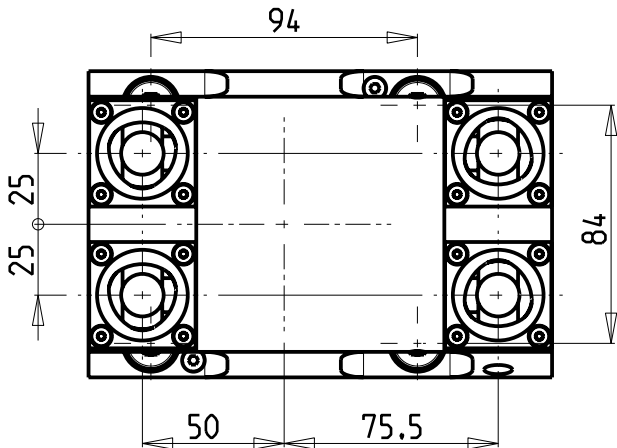

PER ORDINARE LA VERSIONE SX
AGGIUNGERE "LC" AL CODICE IN TABELLA.
ES: MNL0464010 DIVENTA MNL0464010LC

TO ORDER LEFT VERSION
ADD A "LC" IN THE CODE-CHARTS.
EXAMPLE: MNL0464010 BECOMES MNL0464010LC

UM DIE LINKE-VERSION ZU BESTELLEN, BEI DER
ARTIKELBEZEICHNUNG "LC" HINZUFUEGEN.
BEISPIEL: MNL0464010 WIRD DANN MNL0464010LC

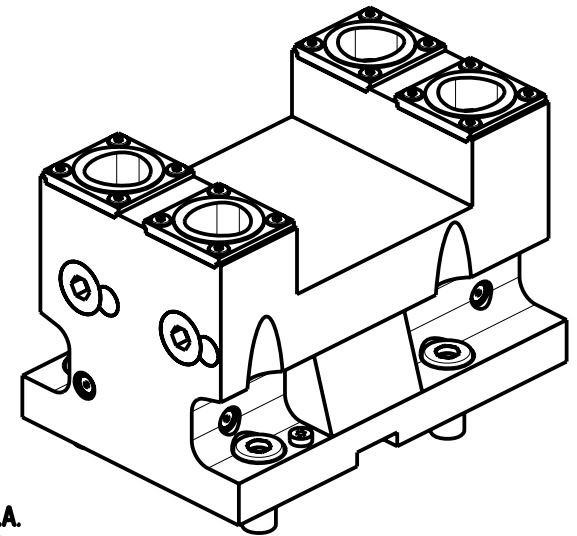

Cod. MT	N°Utensili N°Tools N°Werkzeuge	Lubrificazione int. Coolant through Innenkuehlung	TAGLIA Size Masse
GDW 0403240	4	X	C3

GOODWAY
MOD: GS2600/2800

PORTAUTENSILE RADIALE DOPPIO SOVRAPPOSTO 2+2 POSIZIONI COROMANT CAPTO®
Radial double 2+2 upright position static tool COROMANT CAPTO®
Radial Doppel-Werkzeughalter 2+2 Positionen ueberlagert COROMANT CAPTO®

M.T. srl

Via Casino Albini 480
Tel. 0541/956034-957884
Fax 0541/956341
47842 S. GIOVANNI IN M. (RN)
e-mail: mtma@mtmarchetti.com
http://www.mtmarchetti.com

PRODUZIONE MODULI ROTANTI



PAGINA GDW 460-A-30

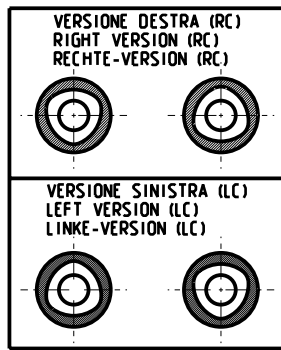
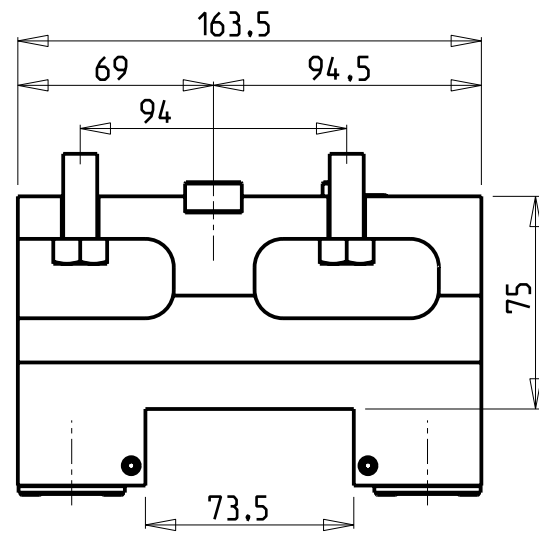
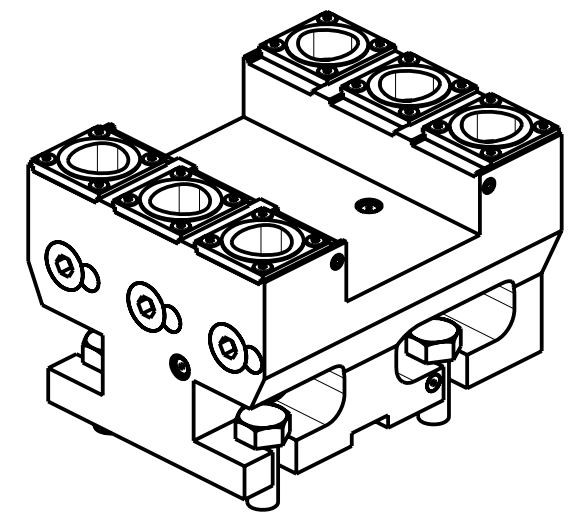
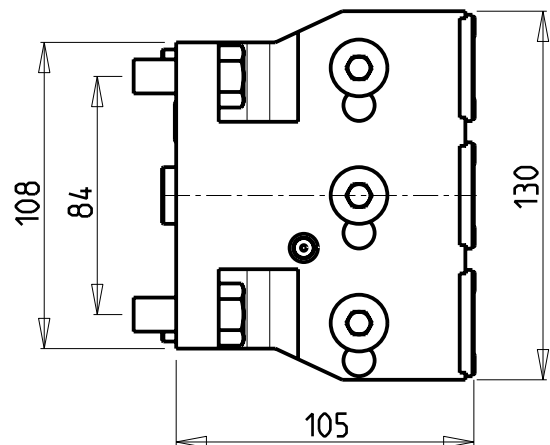
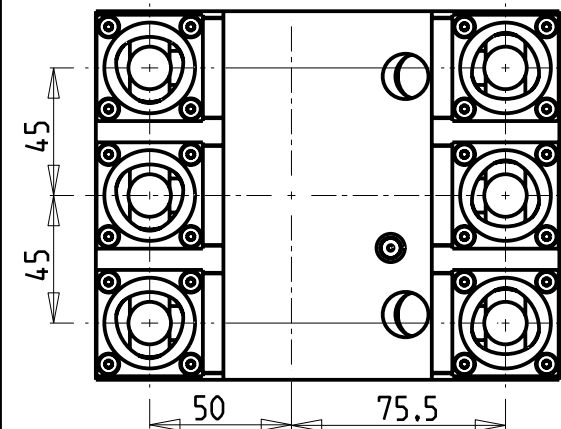

PER ORDINARE LA VERSIONE SX
 AGGIUNGERE "LC" AL CODICE IN TABELLA.
 ES: MNL0464010 DIVENTA MNL0464010LC

TO ORDER LEFT VERSION
 ADD A "LC" IN THE CODE-CHARTS.
 EXAMPLE: MNL0464010 BECOMES MNL0464010LC

UM DIE LINKE-VERSION ZU BESTELLEN, BEI DER
 ARTIKELBEZEICHNUNG "LC" HINZUFUEGEN.
 BEISPIEL: MNL0464010 WIRD DANN MNL0464010LC

Cod. MT	N°Utensili N°Tools N°Werkzeuge	Lubrificazione int. Coolant through Innenkuehlung	TAGLIA Size Masse
GDW 0403260	6	X	C3

GOODWAY
 MOD: GS2600/2800

PORTAUTENSILE RADIALE DOPPIO SOVRAPPOSTO 3+3 POSIZIONI COROMANT CAPTO®
 Radial double 3+3 upright position static tool COROMANT CAPTO®
 Radial Doppel-Werkzeughalter 3+3 Positionen ueberlagert COROMANT CAPTO®



M.T. srl
 Via Casino Albini 480
 Tel. 0541/956034-957884
 Fax 0541/956341
 47842 S. GIOVANNI IN M. (RN)
 e-mail: mtma@mtmarchetti.com
 http://www.mtmarchetti.com

PRODUZIONE MODULI ROTANTI

PAGINA GDW 465-A-30

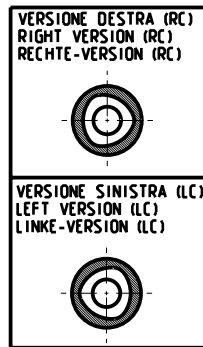
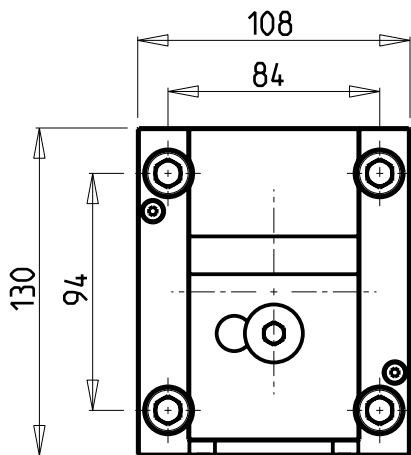
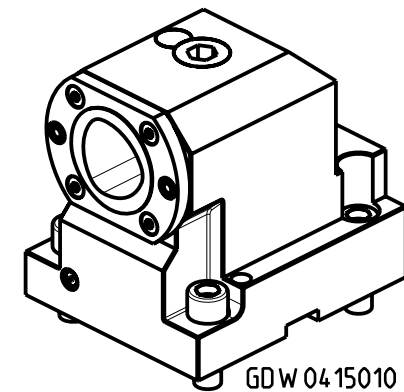
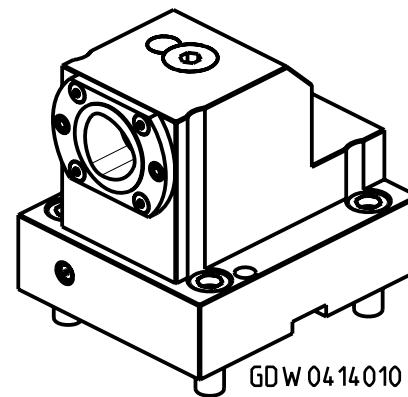
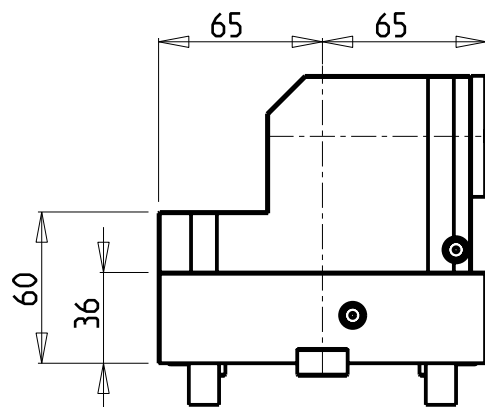
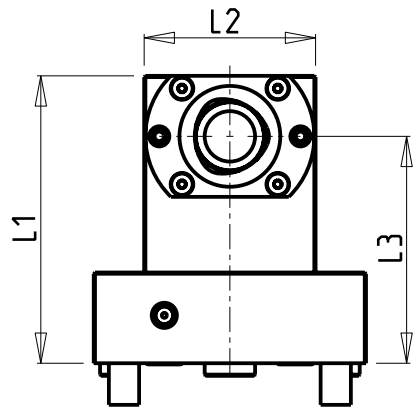

PER ORDINARE LA VERSIONE SX
AGGIUNGERE "LC" AL CODICE IN TABELLA.
ES: MNL0464010 DIVENTA MNL0464010LC

TO ORDER LEFT VERSION
ADD A "LC" IN THE CODE-CHARTS.
EXAMPLE: MNL0464010 BECOMES MNL0464010LC

UM DIE LINKE-VERSION ZU BESTELLEN, BEI DER
ARTIKELBEZEICHNUNG "LC" HINZUFUEGEN.
BEISPIEL: MNL0464010 WIRD DANN MNL0464010LC

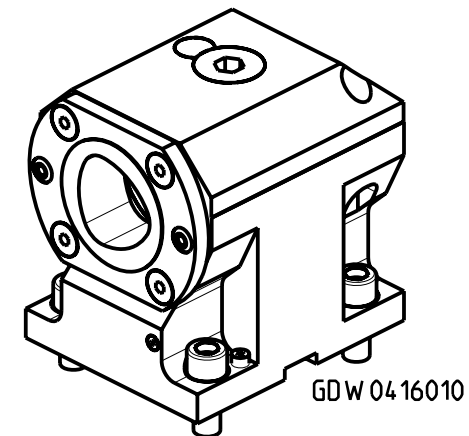

Cod. MT	N°Utensili N°Tools N°Werkzeuge	Lubrificazione int. Coolant through Innenkuehlung	Reversibile lato mandrino/contromandrino Reversible sub/main spindle side Umkehrbare Spindel-seite/ Gegenspindel-seite	TAGLIA Size Masse	L1	L2	L3
GDW 04 14 010	1	X	X	C4	114	68	90
GDW 04 15 010	1	X	X	C5	122	83	90
GDW 04 15 015	1	X	X	C5	152	83	120
GDW 04 16 010	1	X	X	C6	132	108	90

GOODWAY
MOD: GS2600/2800

PORTAUTENSILE ASSIALE SINGOLO COROMANT CAPTO®
Axial single static tool COROMANT CAPTO®
Axial Single-Werkzeughalter COROMANT CAPTO®

M.T. srl

Via Casino Albini 480
Tel. 0541/956034-957884
Fax 0541/956341
47842 S. GIOVANNI IN M. (RN)
e-mail: mtma@mtmarchetti.com
http://www.mtmarchetti.com

PRODUZIONE MODULI ROTANTI



PAGINA GDW 550-A-40

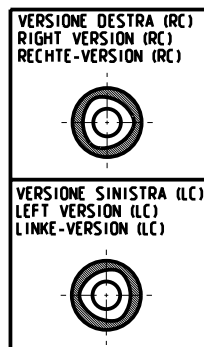
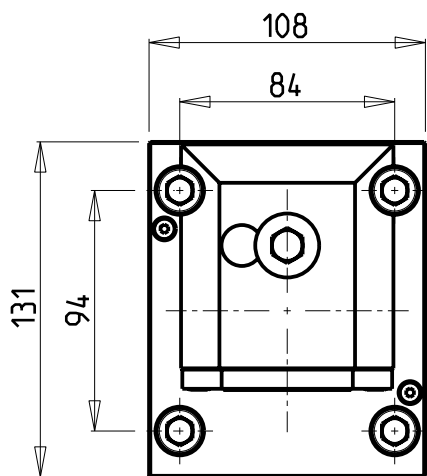
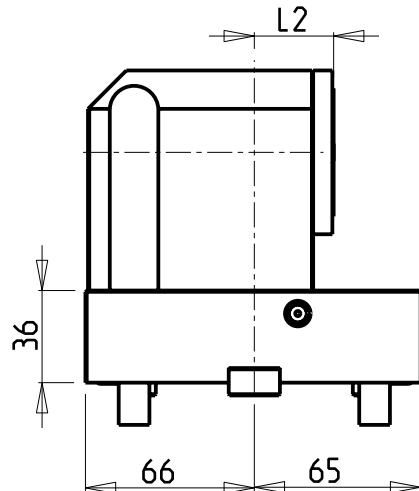
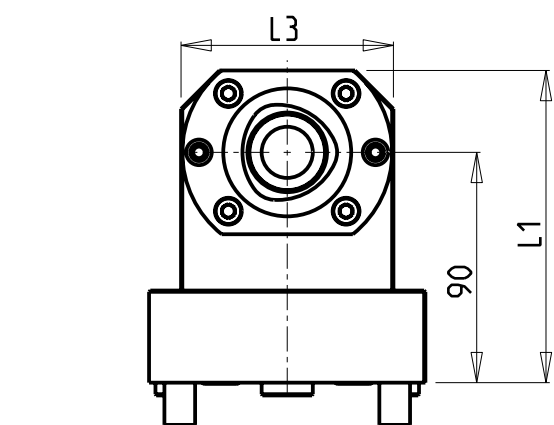

PER ORDINARE LA VERSIONE SX
AGGIUNGERE "LC" AL CODICE IN TABELLA.
ES: MNL0464010 DIVENTA MNL0464010LC

TO ORDER LEFT VERSION
ADD A "LC" IN THE CODE-CHARTS.
EXAMPLE: MNL0464010 BECOMES MNL0464010LC

UM DIE LINKE-VERSION ZU BESTELLEN, BEI DER
ARTIKELBEZEICHNUNG "LC" HINZUFUEGEN.
BEISPIEL: MNL0464010 WIRD DANN MNL0464010LC

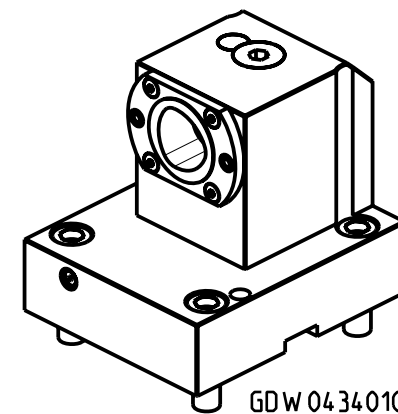
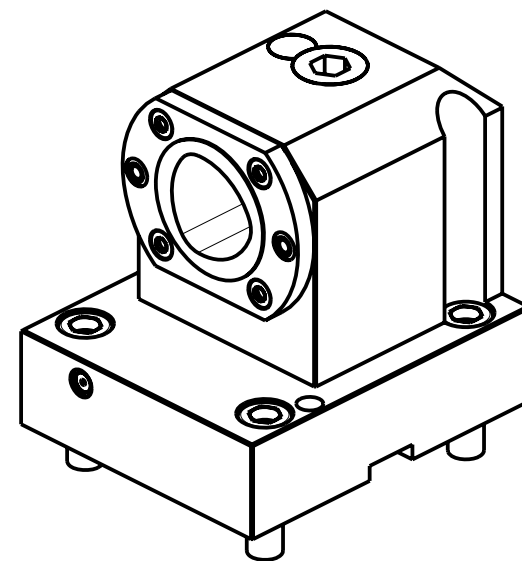

Cod. MT	N°Utensili N°Tools N°Werkzeuge	Lubrificazione int. Coolant through Innenkuehlung	Reversibile lato mandrino/contromandrino Reversible sub/main spindle side Umkehrbare Spindelseite/ Gegenspindelseite	TAGLIA Size Masse	L1	L2	L3
GDW 0434010	1	X	X	C4	114	21	68
GDW 0435010	1	X	X	C5	122	31	83

GOODWAY
MOD: GS2600/2800

PORTAUTENSILE ASSIALE SINGOLO ARRETRATO COROMANT CAPTO®
Axial rear-set single static tool COROMANT CAPTO®
Axial Single-Werkzeughalter zurueckversetzt COROMANT CAPTO®

M.T. srl

Via Casino Albini 480
Tel. 0541/956034-957884
Fax 0541/956341
47842 S. GIOVANNI IN M. (RN)
e-mail: mtma@mtmarchetti.com
http://www.mtmarchetti.com

PRODUZIONE MODULI ROTANTI



PAGINA GDW 555-A-40

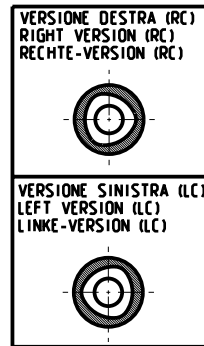
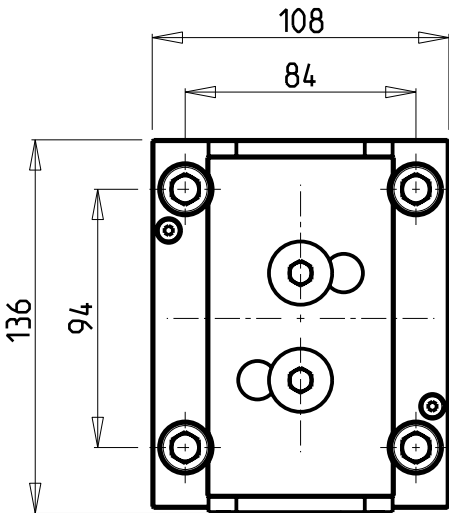
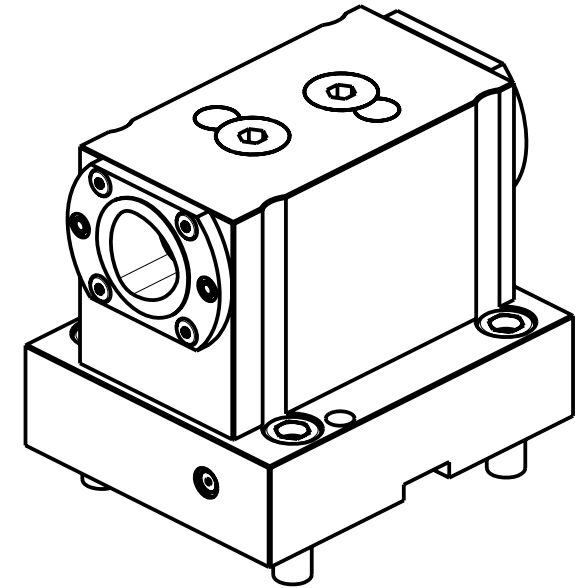
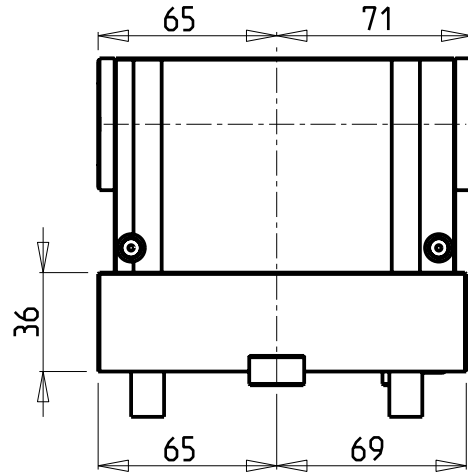
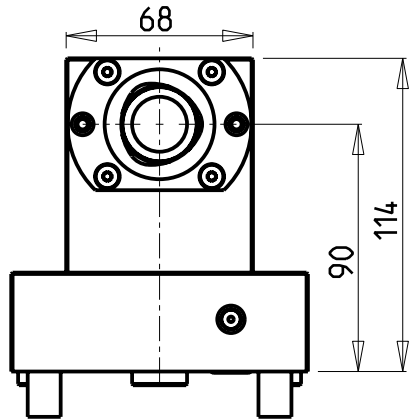

PER ORDINARE LA VERSIONE SX
AGGIUNGERE "LC" AL CODICE IN TABELLA.
ES: MNL0464010 DIVENTA MNL0464010LC

TO ORDER LEFT VERSION
ADD A "LC" IN THE CODE-CHARTS.
EXAMPLE: MNL0464010 BECOMES MNL0464010LC

UM DIE LINKE-VERSION ZU BESTELLEN, BEI DER
ARTIKELBEZEICHNUNG "LC" HINZUFUEGEN.
BEISPIEL: MNL0464010 WIRD DANN MNL0464010LC

Cod. MT	N°Utensili N°Tools N°Werkzeuge	Lubrificazione int. Coolant Through Innenkuehlung	Reversibile lato mandrino/contromandrino Reversible sub/main spindle side Umkehrbare Spindel-seite/ Gegenspindel-seite	TAGLIA Size Masse
GDW 0424020	1+1	X	X	C4

GOODWAY
MOD: GS2600/2800

PORTAUTENSILE ASSIALE BISPORGENTE COROMANT CAPTO®
Axial opposite face twin static tool COROMANT CAPTO®
Axial Werkzeughalter halb vorspringend mit COROMANT CAPTO®

M.T. srl

Via Casino Albini 480
Tel. 0541/956034-957884
Fax 0541/956341
47842 S. GIOVANNI IN M. (RN)
e-mail: mtma@mtmarchetti.com
http://www.mtmarchetti.com

PRODUZIONE MODULI ROTANTI



PAGINA GDW570-A-40

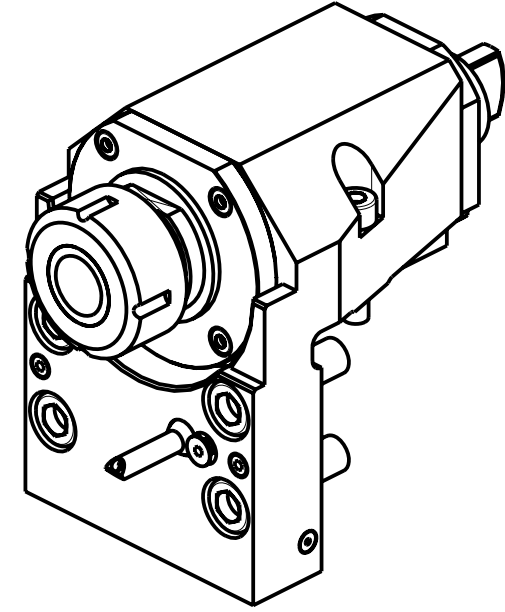
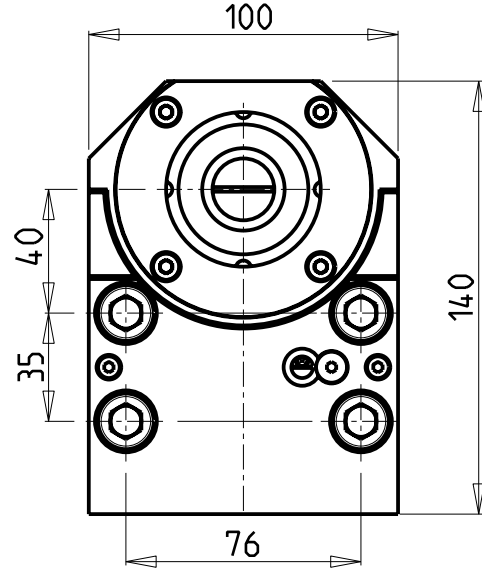
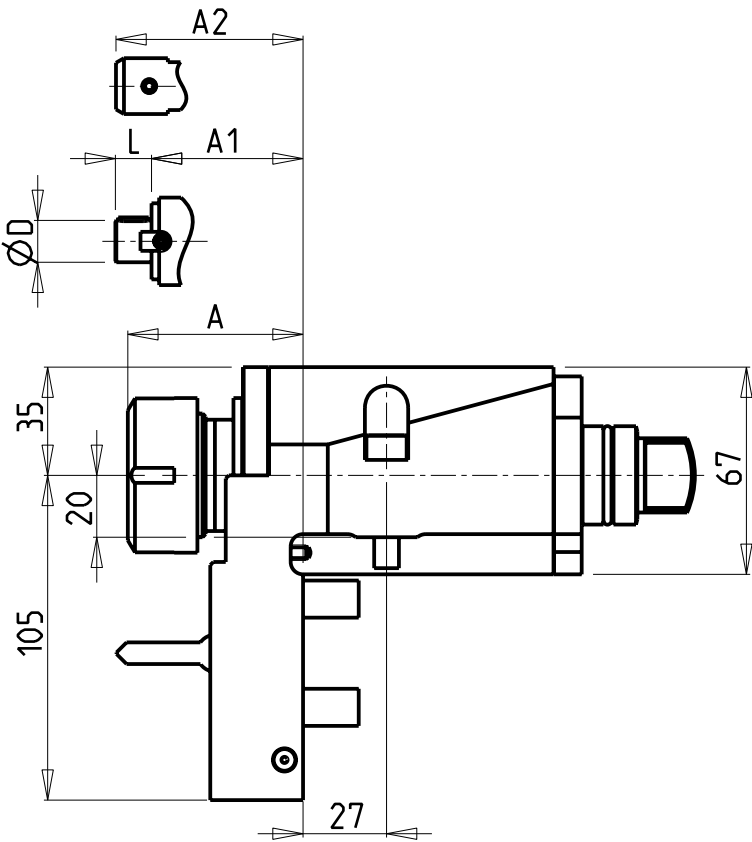

- Chiave inclusa
- Key included
- Schluessel inbegriffen

Cod. MT	Mandrino Spindle Spindel	I	RPM	Coppia Max Max Torque Max Drehmoment	Lubrificazione int. Coolant through Innenkuehlung	Lubrificazione est. Ext. coolant Aussenkuehlung	A	A1	A2	D	L	CHIAVI NON INCLUSE Keys not included Schluessel nicht einbegriffen		
M0010125	ERA25	1:1	6000	70Nm		X	28.7					CHUB42	CHUB27	CHTAER25ZC •
M0010232	ER32	1:1	6000	70Nm		X	56.66					CHUB36		CHSTER32
M0011732	ER32	1:1	6000	70Nm	P=30bar		68.26					CHUB36		CHSTER32
M0012016	∅16x17	1:1	6000	70Nm	P=30bar			51.6		16	17	CHUB36		CH_VTCROCE_M08 •
M0012125	WELDON 25	1:1	6000	70Nm	P=30bar									

GOODWAY
 MOD: GS200/260/280 GA200
 MODULO MOTORIZZATO RADIALE
 Radial driven tool
 Radial angetriebenes Werkzeug

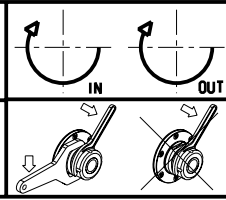

M.T. srl
 Via Casino Albini 480
 Tel. 0541/956034-957884
 Fax 0541/956341
 47842 S. GIOVANNI IN M. (RN)
 e-mail: mtma@mtmarchetti.com
 http://www.mtmarchetti.com

PRODUZIONE MODULI ROTANTI

PAGINA GDW 010-2-00

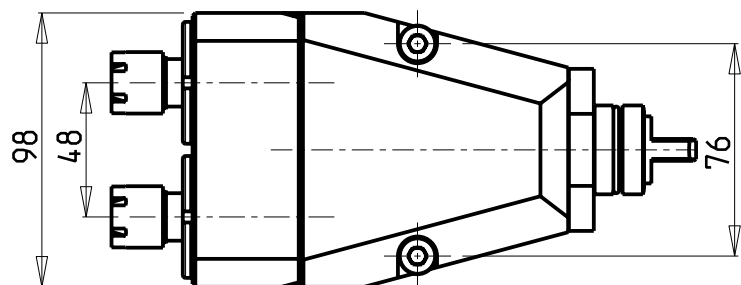
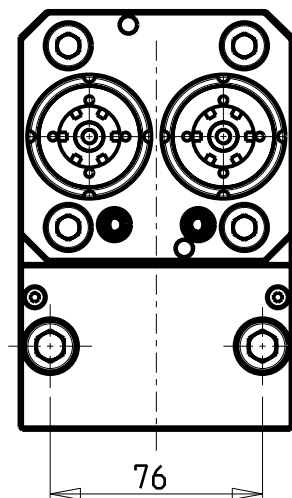
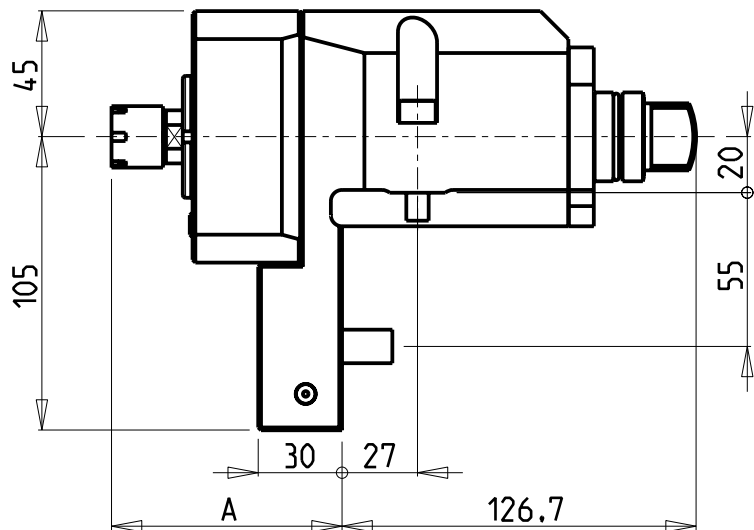

ATTENZIONE - ATTENTION - ACHTUNG

- Per lo smontaggio degli utensili utilizzare sempre la chiave di contrasto come indicato nel manuale d'uso.
- For disassembly of the tools use always the contrast key as mentioned in the user instructions.
- Fuer das Abmontieren der Werkzeuge immer den Gegenschlüssel benutzen wie in der Bedienungsanleitung erwäehnt.

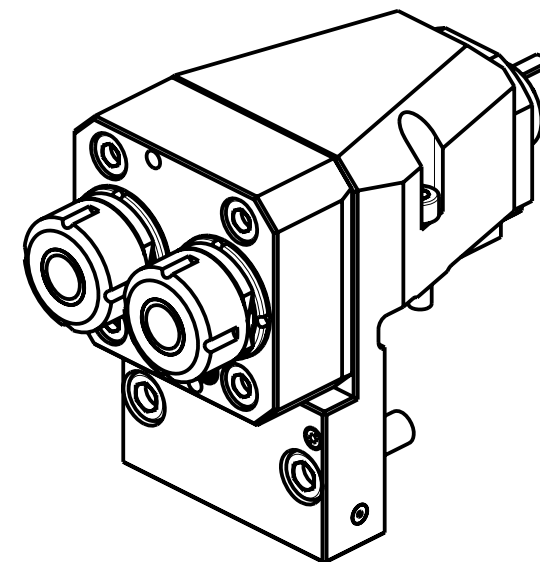

Cod. MT	Mandrino Spindle Spindel	I	RPM	Coppia Max Max Torque Max Drehmoment	Lubrificazione est. Ext. coolant Ausseukuehlung	A	CHIAVI NON INCLUSE Keys not included Schlüssel nicht einbegriffen	
							CHUB17	CHMNER16
M0300016	ER16	1:1	6000	30Nm	X	82.5	CHUB17	CHMNER16
M0300025	ER25	1:1	6000	30Nm	X	82.96	MNL0210007	CHSTER25

GOODWAY

MOD: GS200/260/280 GA200

MODULO MOTORIZZATO RADIALE 2 USCITE IN Y
Radial single side twin head driven tool in Y
Radial angetriebenes Werkzeug 2 Ausgaenge in Y

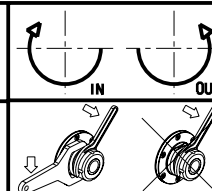

M.T. srl

Via Casino Albini 480
Tel. 0541/956034-957884
Fax 0541/956341

47842 S. GIOVANNI IN M. (RN)
e-mail: mtma@mtmarchetti.com
http://www.mtmarchetti.com

PRODUZIONE MODULI ROTANTI



PAGINA GDW080-2-00

ATTENZIONE - ATTENTION - ACHTUNG

- Per lo smontaggio degli utensili utilizzare sempre la chiave di contrasto come indicato nel manuale d'uso.
- For disassembly of the tools use always the contrast key as mentioned in the user instructions.
- Fuer das Abmontieren der Werkzeuge immer den Gegenschlüssel benutzen wie in der Bedienungsanleitung erwaeht.

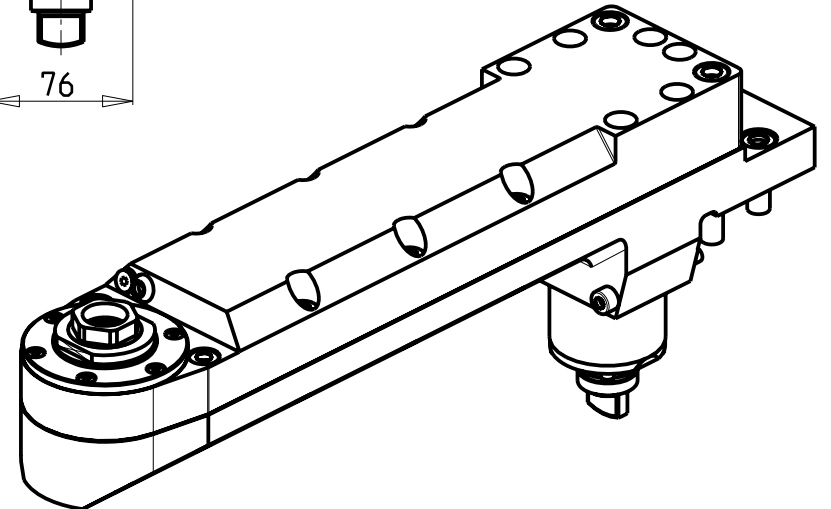
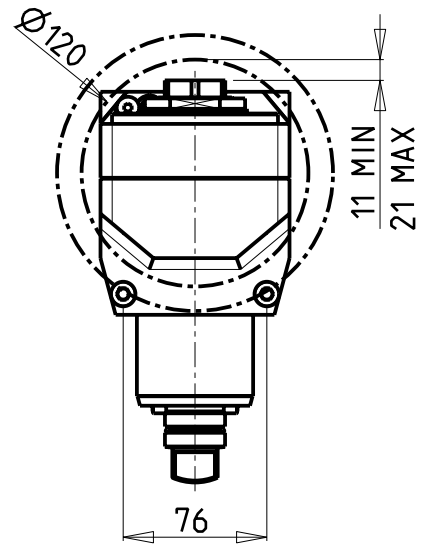
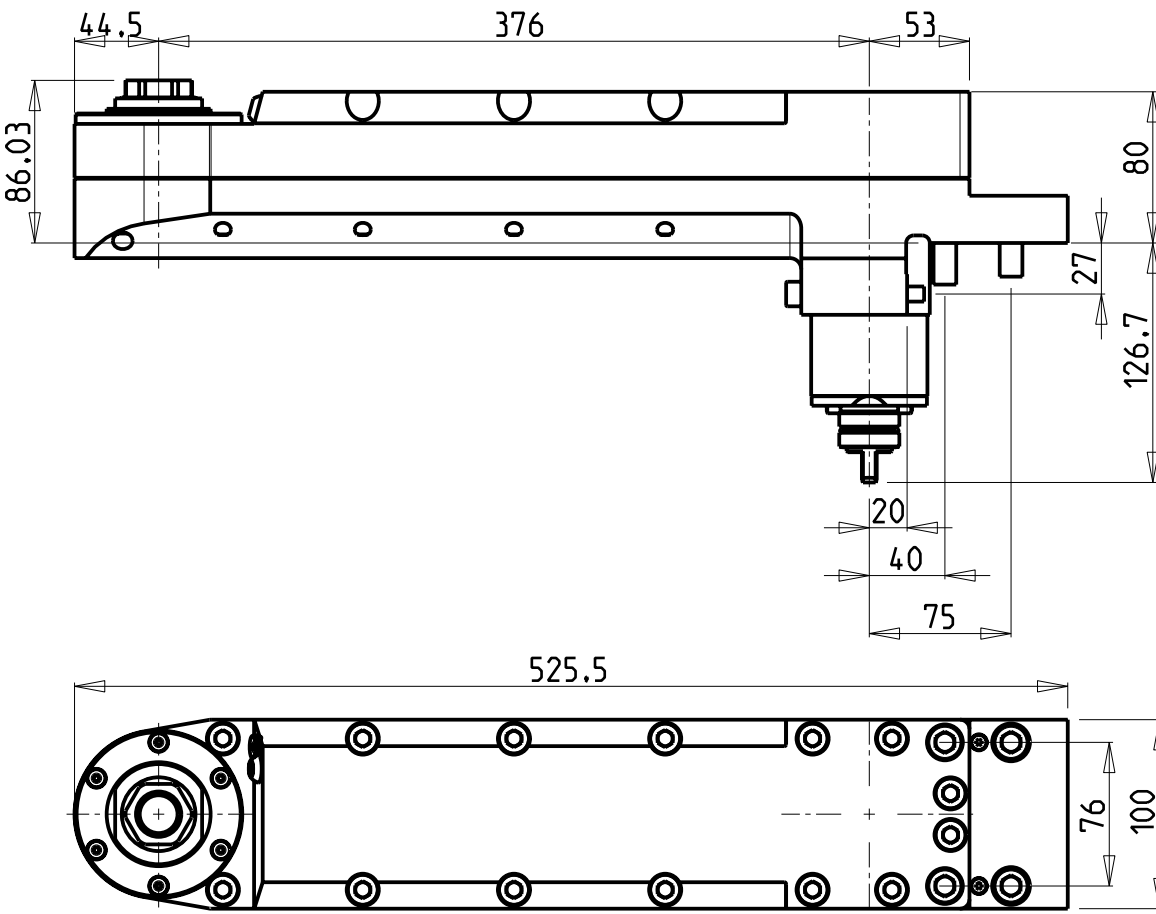

Cod. MT	Mandrino Spindle Spindel	I	RPM	Coppia Max Max Torque Max Drehmoment	Lubrificazione est. Ext. coolant Aussenkuehlung	CHIAVI INCLUSE Keys included Schluessel inbegriffen	
MSL0010132	ER A 32	1:1	6000	50Nm	X	CHUB46	CHUB32

GOODWAY
MOD: GS200/260/280 GA200

MODULO MOTORIZZATO SPECIALE RADIALE DISASSATO IN Z 376mm
Radial special driven tool re-directed in Z by 376mm
Radial spezial angetriebenes Werkzeug achsversetzt in Z um 376mm

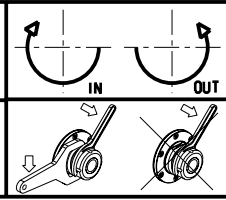

M.T. srl
Via Casino Albini 480
Tel. 0541/956034-957884
Fax 0541/956341
47842 S. GIOVANNI IN M. (RN)
e-mail: mtma@mtmarchetti.com
http://www.mtmarchetti.com

PRODUZIONE MODULI ROTANTI

PAGINA GDW 125-2-10

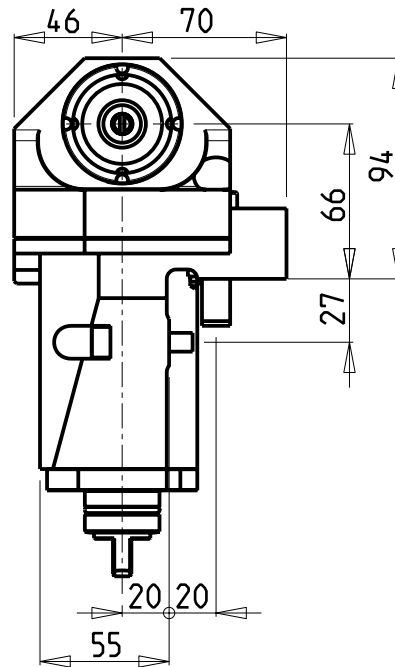
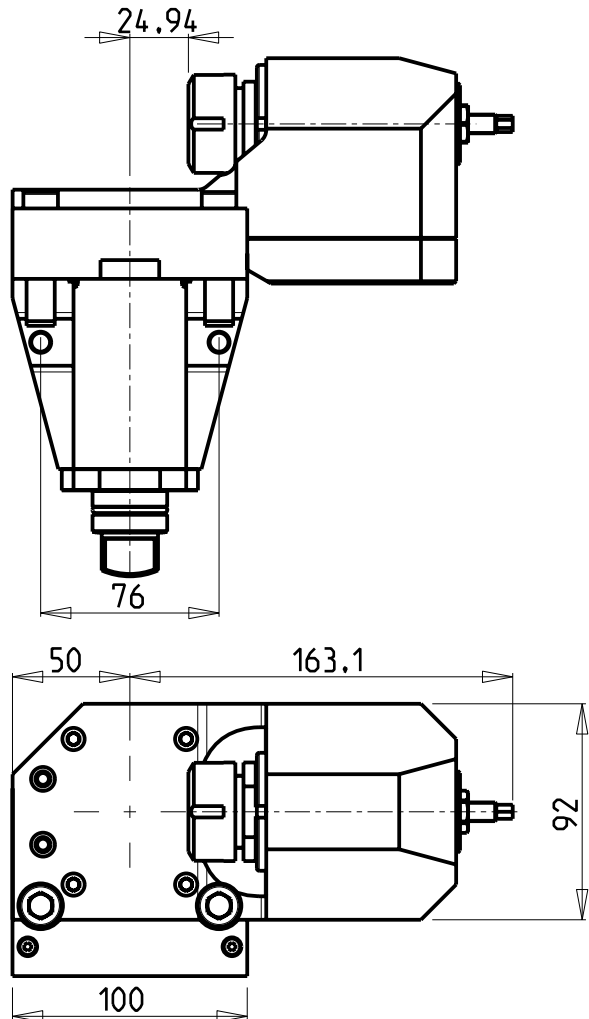

ATTENZIONE - ATTENTION - ACHTUNG

- Per lo smontaggio degli utensili utilizzare sempre la chiave di contrasto come indicato nel manuale d'uso.
- For disassembly of the tools use always the contrast key as mentioned in the user instructions.
- Fuer das Abmontieren der Werkzeuge immer den Gegenschlüssel benutzen wie in der Bedienungsanleitung erwäehnt.

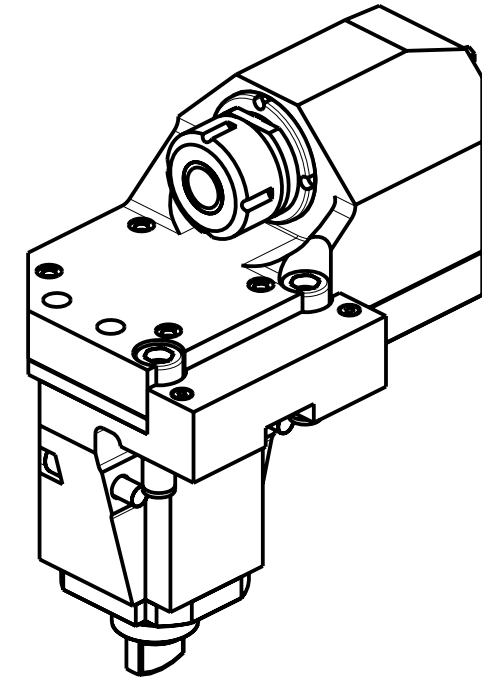

Cod. MT	Mandrino Spindle Spindel	I	RPM	Coppia Max Max Torque Max Drehmoment	Lubrificazione est. Ext. coolant Aussenkuehlung	CHIAVI NON INCLUSE Keys not included Schluesssel nicht einbegriffen	
M0230025	ER 25	1:1	6000	40Nm	X	CHUB36	CHSTER25

GOODWAY
 MOD: GS200/260/280 GA200
 MODULO MOTORIZZATO SPECIALE RADIALE IN Y
 Radial special driven tool in Y
 Radial spezial angetriebenes Werkzeug in Y

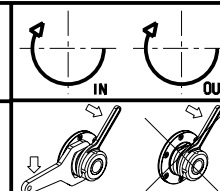

M.T. srl
 Via Casino Albini 480
 Tel. 0541/956034-957884
 Fax 0541/956341
 47842 S. GIOVANNI IN M. (RN)
 e-mail: mtma@mtmarchetti.com
 http://www.mtmarchetti.com

PRODUZIONE MODULI ROTANTI



PAGINA GDW 130-2-00

ATTENZIONE - ATTENTION - ACHTUNG

- Per lo smontaggio degli utensili utilizzare sempre la chiave di contrasto come indicato nel manuale d'uso.
- For disassembly of the tools use always the contrast key as mentioned in the user instructions.
- Fuer das Abmontieren der Werkzeuge immer den Gegenschlüssel benutzen wie in der Bedienungsanleitung erwahnt.

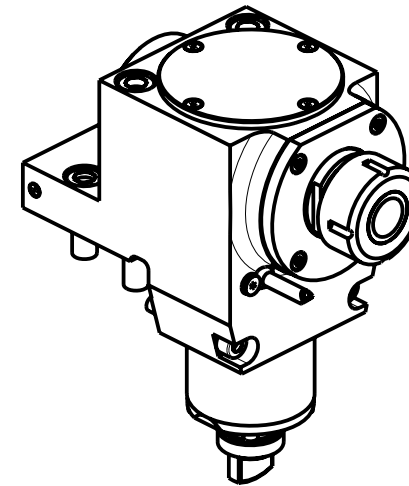
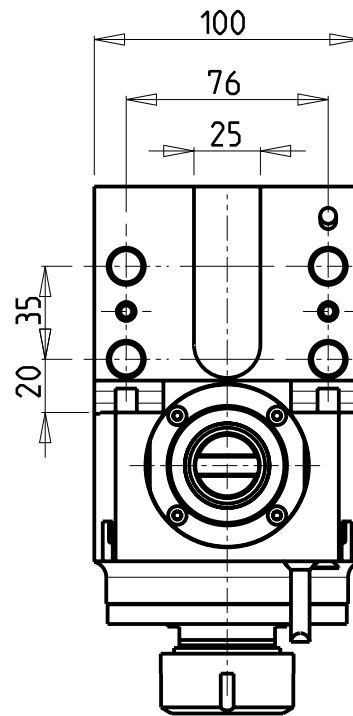
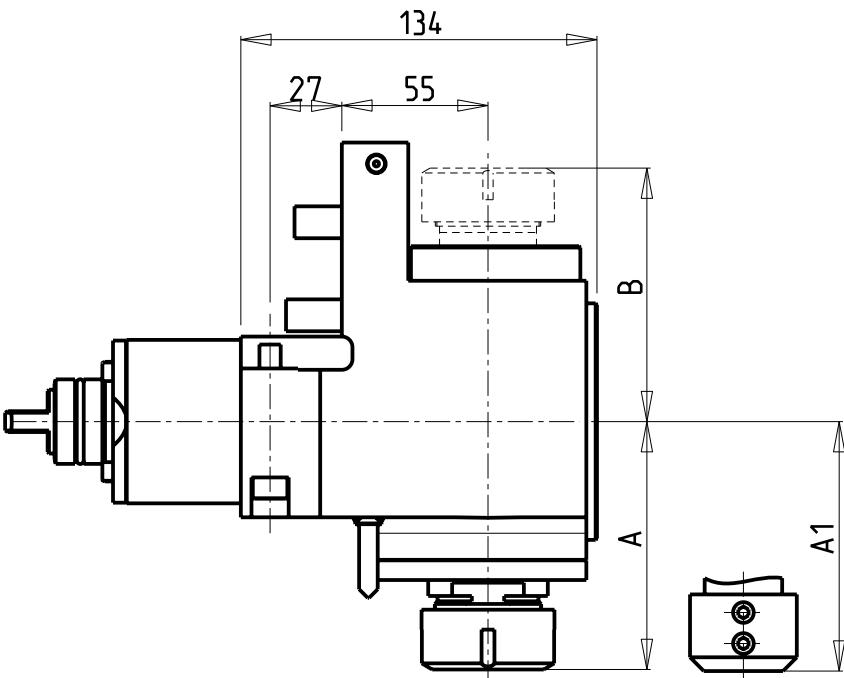

Cod. MT	Mandrino Spindle Spindel	I	RPM	Coppia Max Max Torque Max Drehmoment	Lubrificazione int. Coolant through Innenkuehlung	Lubrificazione est. Ext. coolant Aussenkuehlung	A	A1	B	CHIAVI NON INCLUDE Keys not included Schluessel nicht einbegriffen	
M0030232	ER32	1:1	6000	70Nm		X	93.26	-	-	CHUB36	CHSTER32
M0032032	ER32	1:1	6000	70Nm	P=70bar		93.26	-	-	CHUB36	CHSTER32
M0033232	ER32+ER32	1:1	6000	70Nm		X	94.76	-	109.16	CHUB36	CHSTER32
M0032225	WELDON 25	1:1	6000	70Nm		X	-	105.1	-		

GOODWAY
 MOD: GS200/260/280 GA200
 MODULO MOTORIZZATO ASSIALE
 Axial driven tool
 Axial angetriebenes Werkzeug

M.T. srl
 Via Casino Albini 480
 Tel. 0541/956034-957884
 Fax 0541/956341
 47842 S. GIOVANNI IN M. (RN)
 e-mail: mtma@mtmarchetti.com
 http://www.mtmarchetti.com

PRODUZIONE MODULI ROTANTI

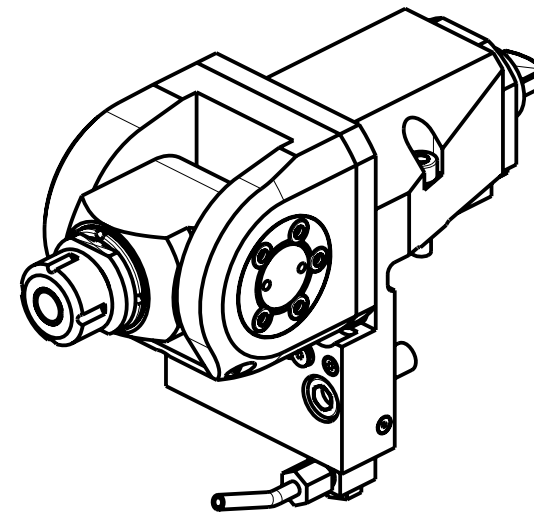
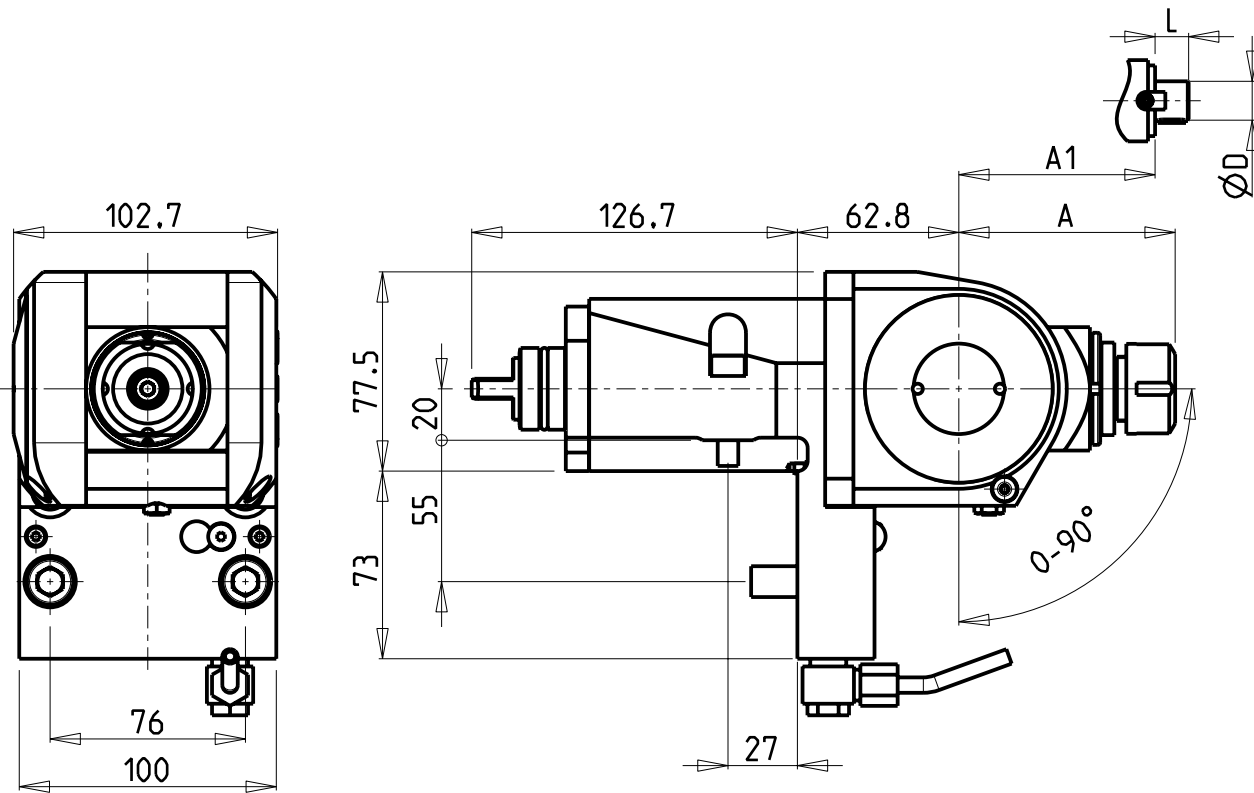
 PAGINA GDW 150-2-10

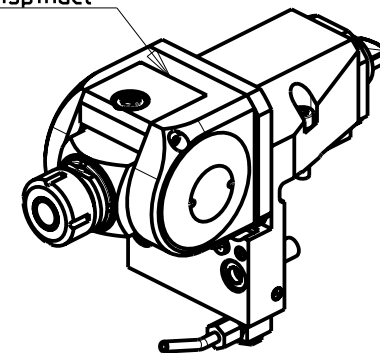

SU ORDINAZIONE PER CONTROMANDRINO
On request for subspindle
Auf Anfrage fuer Gegenspindel



Cod. MT	Mandrino Spindle Spindel	I	RPM	Coppia Max Max Torque Max Drehmoment	Lubrificazione est. Ext. coolant Aussenkuehlung	A	A1	D	L	CHIAVI INCLUSE Keys included Schluessel inbegriffen	
M0060020	ER20	1:1	6000	40Nm	X	84.16	-	-	-	CHUB36	CHSTER20
M0060025	ER25	1:1	6000	40Nm	X	85.66	-	-	-	CHUB36	CHSTER25
M0061617	Ø16x17	1:1	6000	40Nm	X	-	65	16	17	CHUB36	CH_VTCROCE_M08
M0062219	Ø22x19	1:1	6000	40Nm	X	-	66	22	19	CHUB36	CH_VTCROCE_M10
M0061905	Ø3/4"x3/4"	1:1	6000	40Nm	X	-	65	3/4"	3/4"	CHUB36	CH_VTCROCE_M08

GOODWAY

MOD: GS200/260/280 GA200

MODULO MOTORIZZATO ORIENTABILE 0-90°

0-90° adjustable angle driven tool

Angetriebenes Werkzeug schwenkbar 0-90°

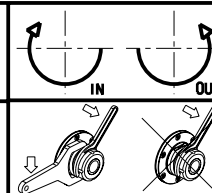

M.T. srl

Via Casino Albini 480
Tel. 0541/956034-957884
Fax 0541/956341

47842 S. GIOVANNI IN M. (RN)
e-mail: mtma@mtmarchetti.com
http://www.mtmarchetti.com

PRODUZIONE MODULI ROTANTI



PAGINA GDW 330-2-00

ATTENZIONE - ATTENTION - ACHTUNG

- Per lo smontaggio degli utensili utilizzare sempre la chiave di contrasto come indicato nel manuale d'uso.
- For disassembly of the tools use always the contrast key as mentioned in the user instructions.
- Fuer das Abmontieren der Werkzeuge immer den Gegenschlüssel benutzen wie in der Bedienungsanleitung erwahnt.

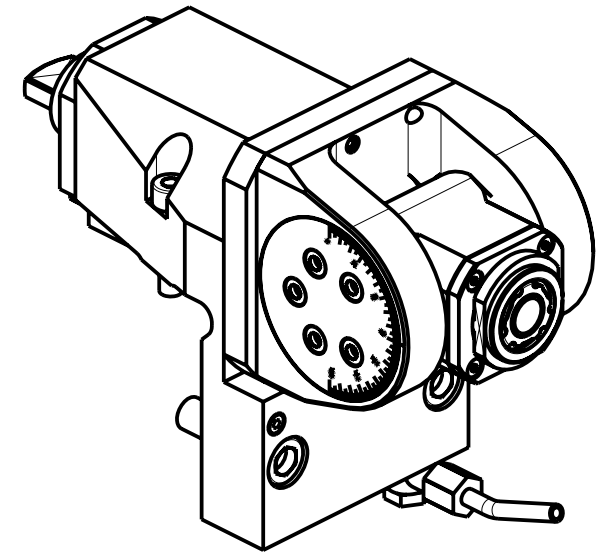
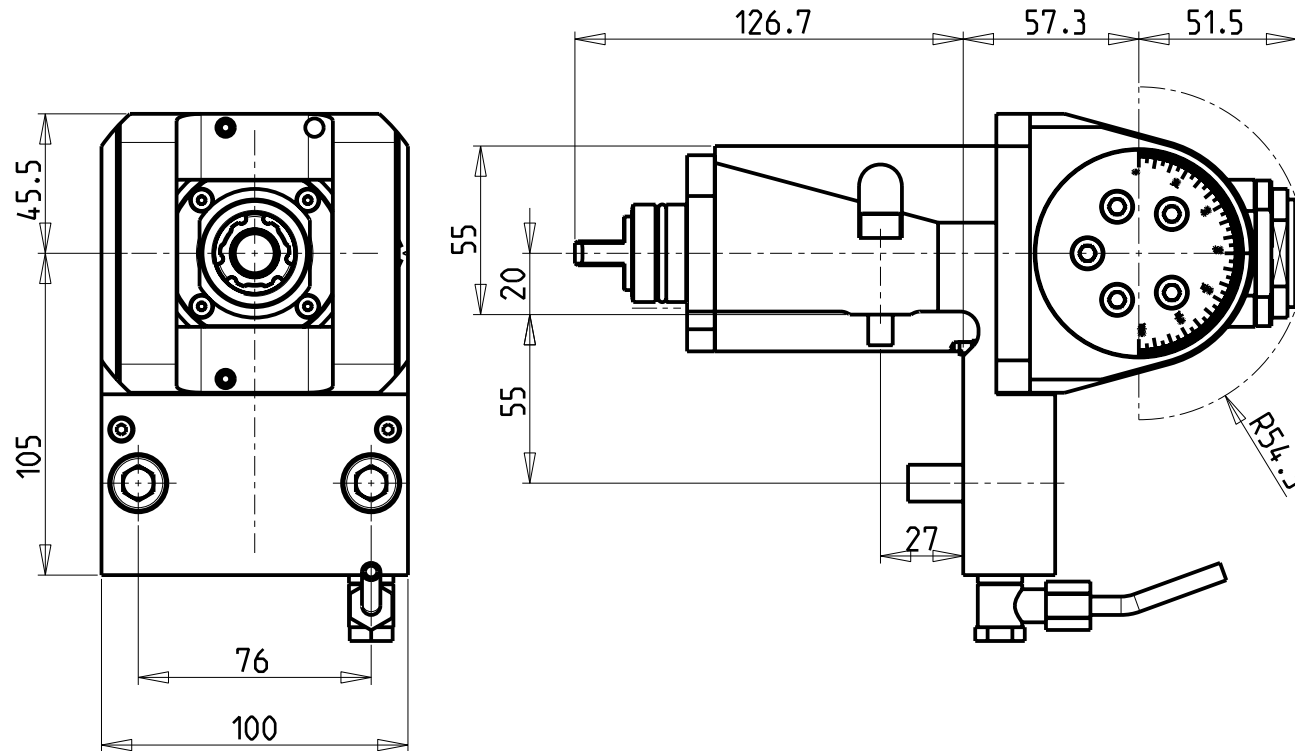

Cod. MT	Mandrino Spindle Spindel	I	RPM	Coppia Max Max Torque Max Drehmoment	Lubrificazione est. Ext. coolant Aussenkuehlung	CHIAVI INCLUSE Keys included Schluessel inbegriffen		
M0220020	ER A 20	1:1	6000	30Nm	X	CHUB36	CHUB22	CHTAER20ZC

GOODWAY
 MOD: GS200/260/280 GA200
 MODULO MOTORIZZATO ORIENTABILE ±90°
 ±90° adjustable angle driven tool
 Angetriebenes Werkzeug schwenkbar ±90°

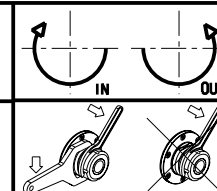

M.T. srl
 Via Casino Albini 480
 Tel. 0541/956034-957884
 Fax 0541/956341
 47842 S. GIOVANNI IN M. (RN)
 e-mail: mtma@mtmarchetti.com
 http://www.mtmarchetti.com

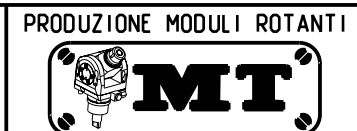

PAGINA GDW 335-2-00

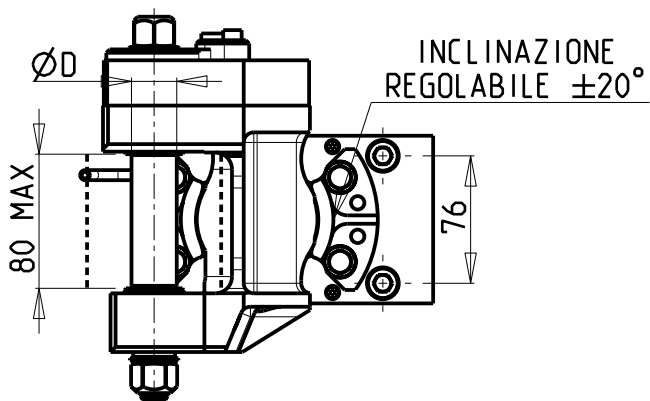
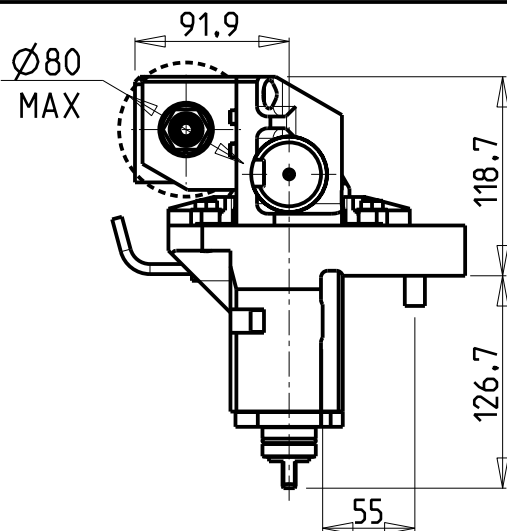
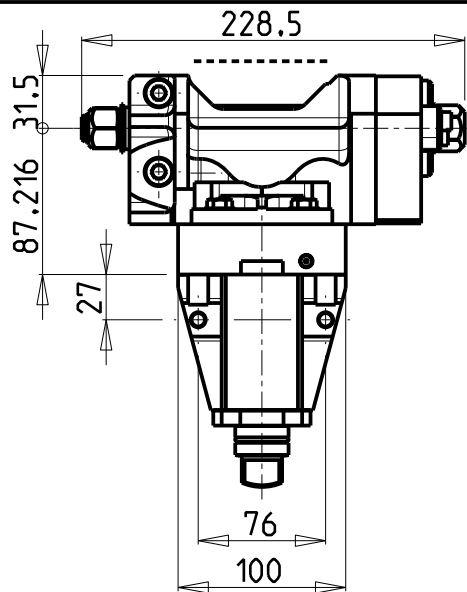

ATTENZIONE - ATTENTION - ACHTUNG

- E' consigliato l'utilizzo su torni dotati di controllo dell'asse Y
- It is recommended to use lathes with the required control of the Y-axis.
- Es ist empfehlenswert Drehbänke, ausgerüstet mit Kontrolle der Y-Achse, zu gebrauchen.

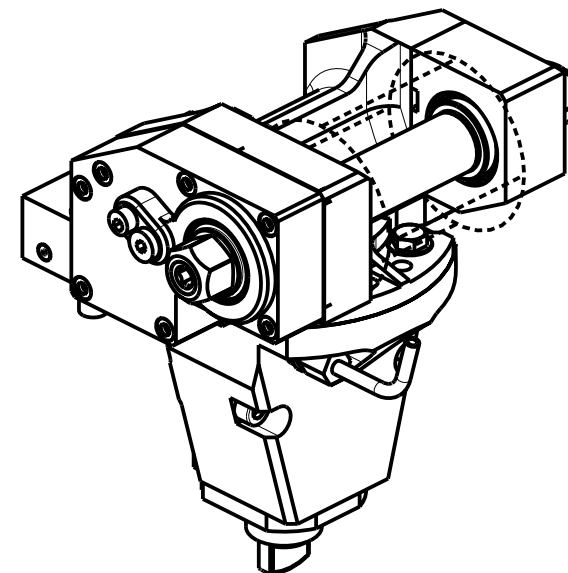

PER ALBERI E DISTANZIALI VEDI PAG. TBL250-1-00
 FOR SHAFT END SPACER SEE PAGE TBL250-1-00
 FUER DORN UND ABSTANDSSTUECK SEITE TBL250-1-00

DOTAZIONI - SUPPLIED WITH - AUSSTATTUNG

- mm / inch
- N°1 ALBERO + DISTANZIALI
 - N°1 SHAFT + SPACER
 - N°1 DORN + ABSTANDSSTUECK

Cod. MT	I	RPM max	Coppia Max Max Torque Max Drehmoment	Lubrificazione est. Ext. coolant Aussenkuehlung	D (mm)	D (Inch)	CHIAVI INCLUSE Keys included Schlüssel inbegriffen		
							CHUB24	CHUB13	CHESL08
M0081100	1:1	6000	60Nm	X	16-22-27-32	3/4"-1"-1 1/4"	CHUB24	CHUB13	CHESL08
M0082100	2:1	3000	80Nm	X	16-22-27-32	3/4"-1"-1 1/4"	CHUB24	CHUB13	CHESL08

GOODWAY
 MOD: GS200/260/280 GA200

MODULO MOTORIZZATO PORTACREATORE
 Driven gear hobber
 Angetriebenes Zahnradwaelzfraes-Werkzeug

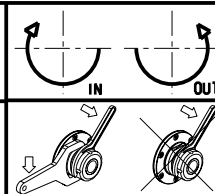

M.T. srl
 Via Casino Albini 480
 Tel. 0541/956034-957884
 Fax 0541/956341
 47842 S. GIOVANNI IN M. (RN)
 e-mail: mtma@mtmarchetti.com
 http://www.mtmarchetti.com

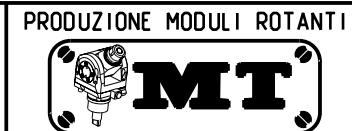

PAGINA GDW 340-2-00

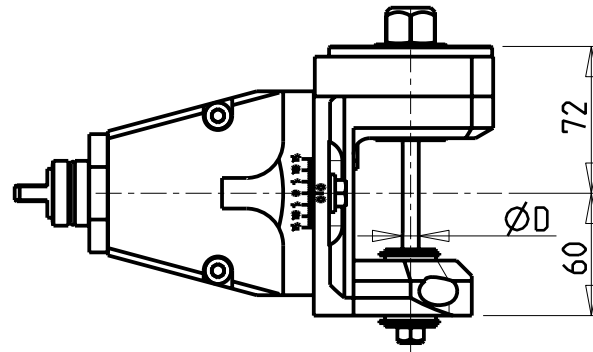
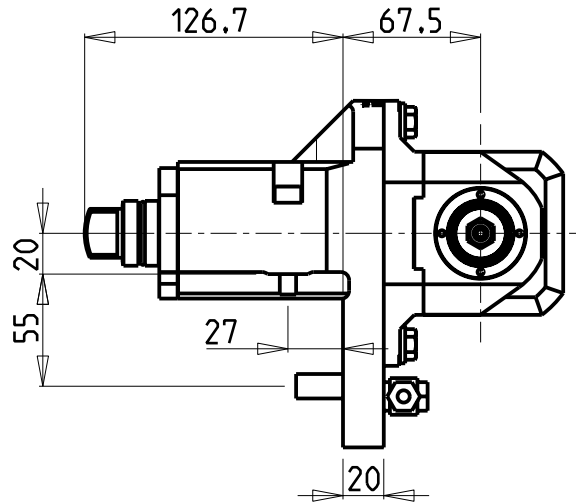
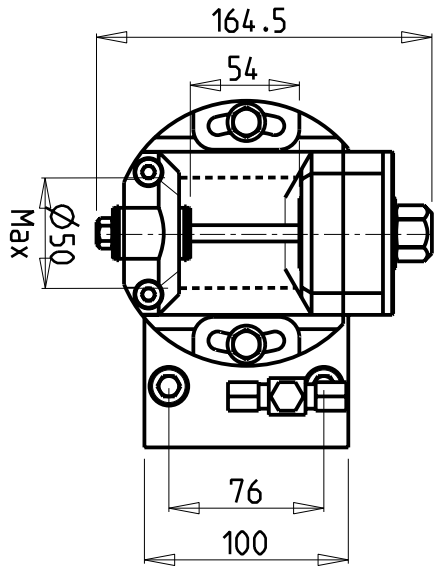

ATTENZIONE - ATTENTION - ACHTUNG

- E' consigliato l'utilizzo su torni dotati di controllo dell'asse Y
- It is recommended to use lathes with the required control of the Y-axis.
- Es ist empfehlenswert Drehbänke, ausgerüstet mit Kontrolle der Y-Achse, zu gebrauchen.

INCLINAZIONE
REGOLABILE $\pm 15^\circ$

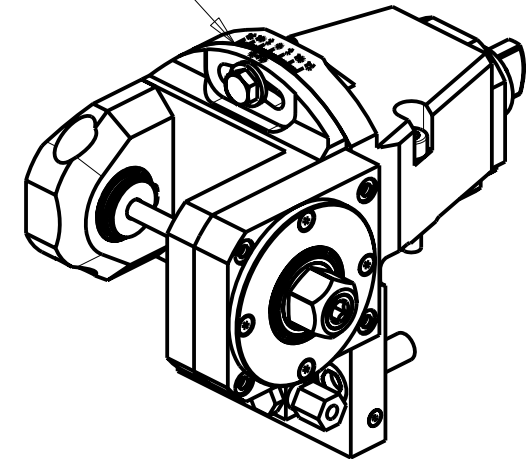

DOTAZIONI - SUPPLIED WITH - AUSSTATTUNG

- | mm / inch | |
|-----------|-----------------------------|
| | - N°1 ALBERO + DISTANZIALI |
| | - N°1 SHAFT + SPACER |
| | - N°1 DORN + ABSTANDSSTUECK |

Cod. MT	i	RPM max	Coppia Max Max Torque Max Drehmoment	Lubrificazione est. Ext. coolant Auslenkuehlung	D	CHIAVI INCLUSE Keys included Schluessel inbegriffen				
M0311108	1:1	6000	50Nm	X	8	CHUB24	CHUB13	CHESL08	CHESL04	
M0311110	1:1	6000	50Nm	X	10	CHUB24	CHUB17	CHUB13	CHESL08	CHESL05
M0311113	1:1	6000	50Nm	X	13	CHUB24	CHUB19	CHUB13	CHESL08	CHESL06
M0311116	1:1	6000	50Nm	X	16	CHUB24	CHUB13	CHESL08		

GOODWAY
MOD: GS200/260/280 GA200

MODULO MOTORIZZATO PORTACREATORE RADIALE
Radial driven gear hobber
Radial angetriebenes Zahnradwaelzfraes-Werkzeug

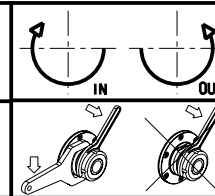

M.T. srl
Via Casino Albini 480
Tel. 0541/956034-957884
Fax 0541/956341
47842 S. GIOVANNI IN M. (RN)
e-mail: mtma@mtmarchetti.com
http://www.mtmarchetti.com

PRODUZIONE MODULI ROTANTI



PAGINA GDW 340-2-30

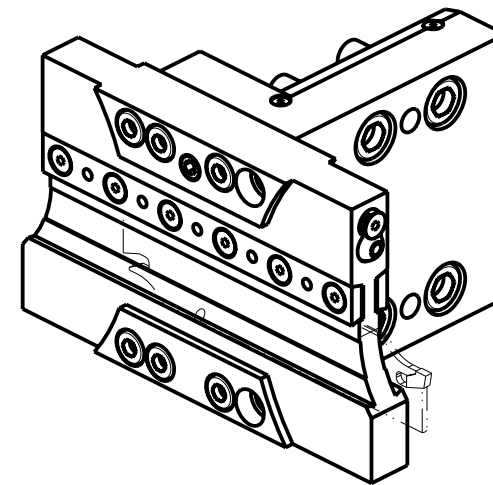
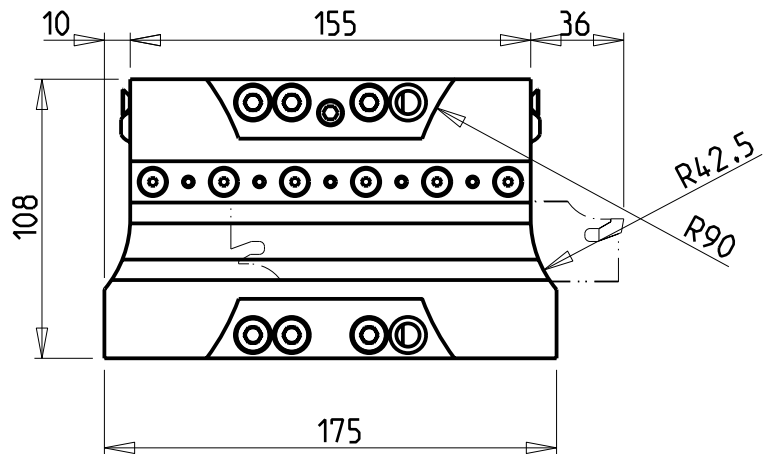
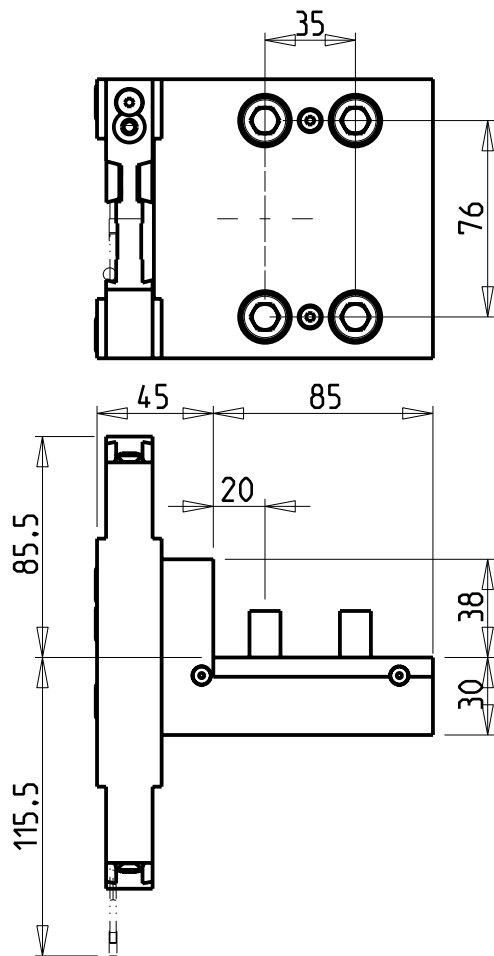

POSSIBILITA' DI LAVORO M3/M4
 OPTION OF. M3/M4 WORKING
 ARBEITSMOGLICHKEIT M3/M4

DOTAZIONI - SUPPLIED WITH - AUSSTATTUNG

- N°1 - LAMA - BLADE - KLINGE ISCAR H=32 Sp. 3/4mm
(KENNAMETAL OPTIONAL)
- N°10 - INSERTI - INSERTS - EINLAGEN
- N°1 - CHIAVE A T PER MONTAGGIO INSERTI
 - T-WRENCH FOR INSERT SET UP
 - T-SCHLUESSEL FUER EINSATZSTUECK-MONTAGE

Cod. MT

N°Utensili
 N°Tools
 N°Werkzeuge

M0250132

1

GOODWAY
 MOD: GS200/260/280 GA200

PORTAUTENSILE PER LAMA DOPPIO
 Radial double blade holder
 Radial Doppel-Abstechhalter

M.T. srl

Via Casino Albini 480
 Tel. 0541/956034-957884
 Fax 0541/956341
 47842 S. GIOVANNI IN M. (RN)
 e-mail: mtma@mtmarchetti.com
 http://www.mtmarchetti.com

PRODUZIONE MODULI ROTANTI



PAGINA GDW520-2-00

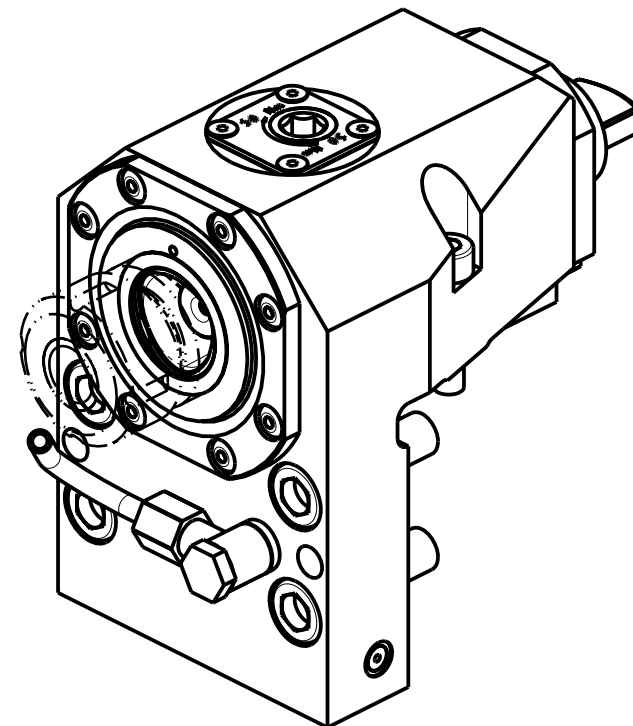
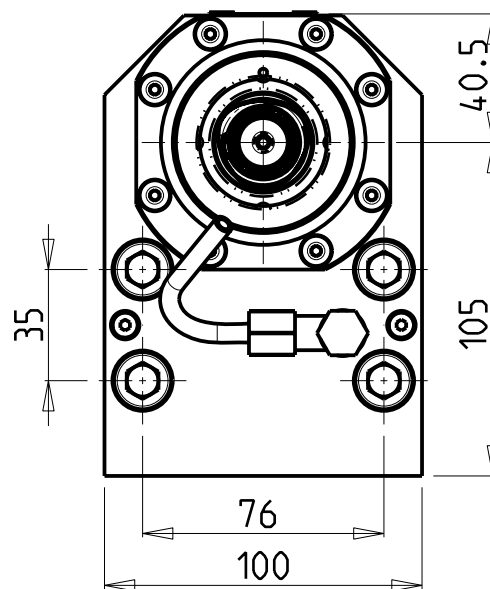
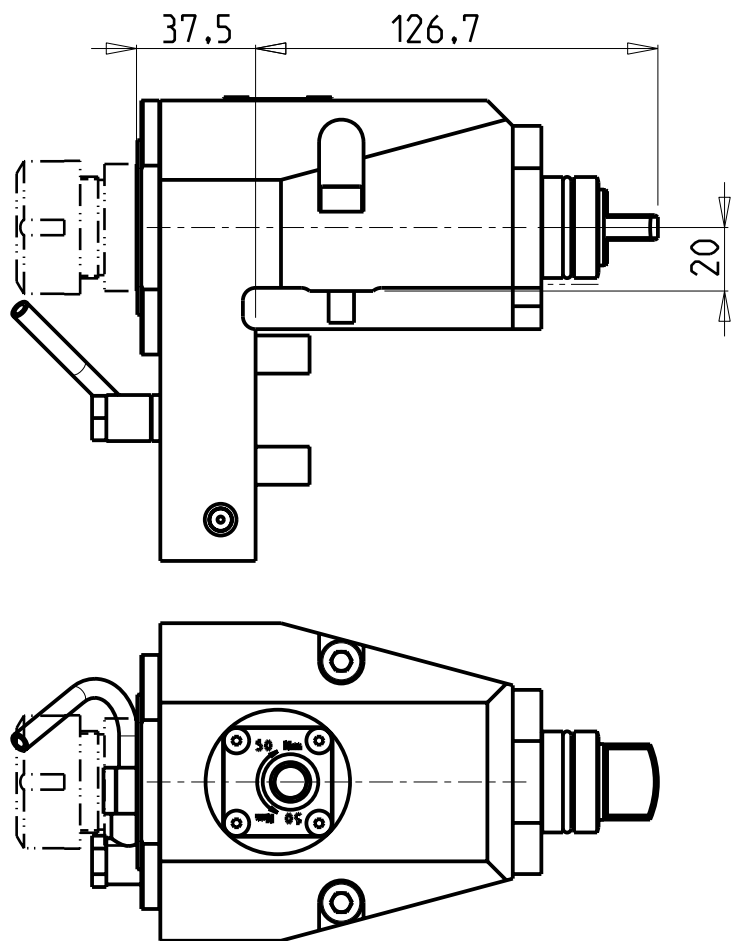

Cod. MT	TAGLIA Size Masse	I	RPM	Coppia Max Max Torque Max Drehmoment	Lubr.esterna Ext. coolant Aussehenkuehlung
MSL0060140	C4	1:1	6000	70Nm	X

GOODWAY
MOD: GS200/260/280 GA200

MODULO MOTORIZZATO RADIALE COROMANT CAPTO®
Radial driven tool COROMANT CAPTO®
Radial angetriebenes Werkzeug COROMANT CAPTO®

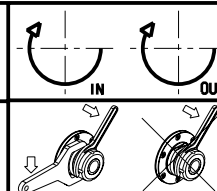

M.T. srl
Via Casino Albini 480
Tel. 0541/956034-957884
Fax 0541/956341
47842 S. GIOVANNI IN M. (RN)
e-mail: mtma@mtmarchetti.com
<http://www.mtmarchetti.com>

PRODUZIONE MODULI ROTANTI



PAGINA GDW 010-B-40

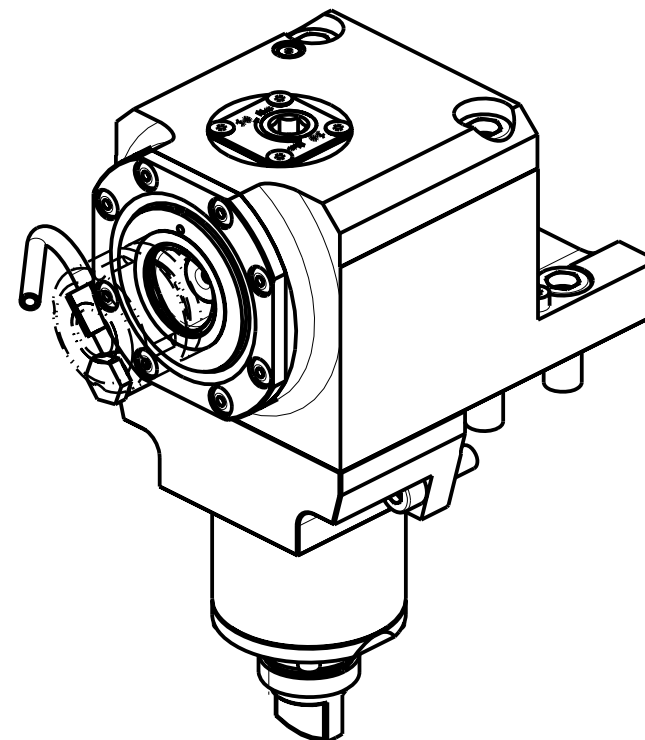
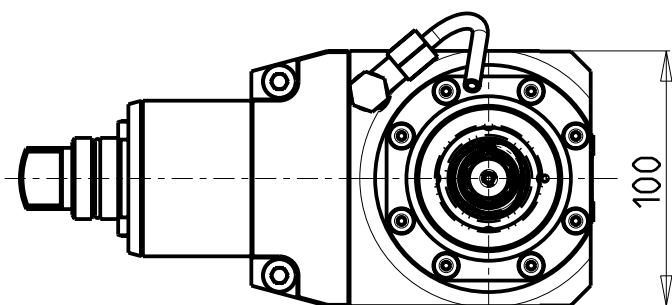
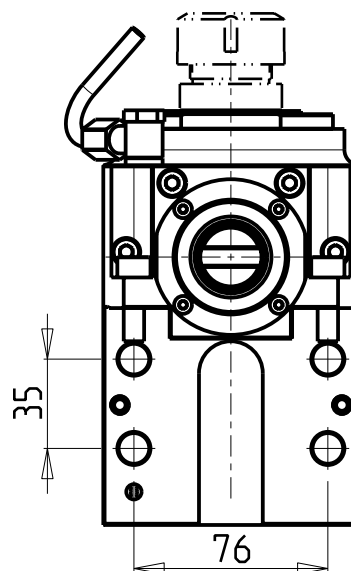
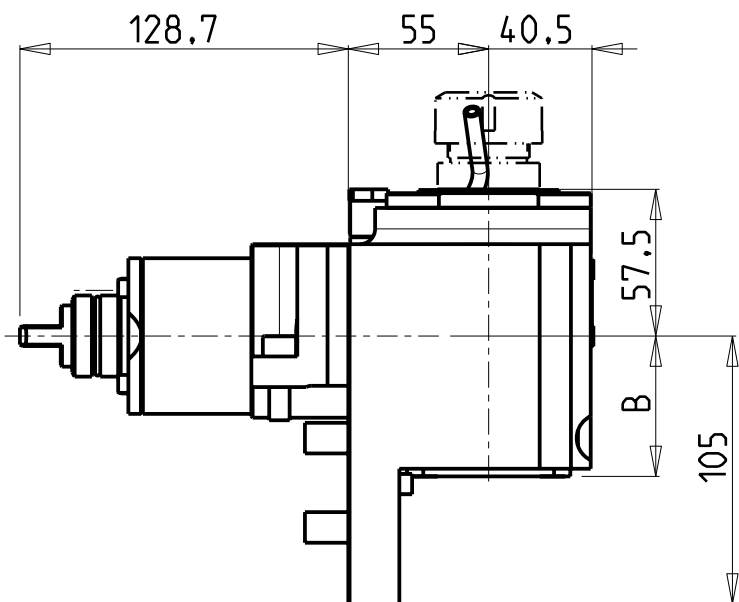

Cod. MT	TAGLIA Size Masse	I	RPM	Coppia Max Max Torque Max Drehmoment	Lubr.interna Coolant through Innenkuehlung	Lubr.esterna Ext. coolant Aussenkuehlung	B
MSL0050140	C4	1:1	6000	70Nm		X	55
MSL0050240	C4	1:1	6000	70Nm	P=70bar	X	68.5

GOODWAY
MOD: GS200/260/280 GA200

MODULO MOTORIZZATO ASSIALE COROMANT CAPTO®
Axial driven tool COROMANT CAPTO®
Axial angetriebenes Werkzeug COROMANT CAPTO®

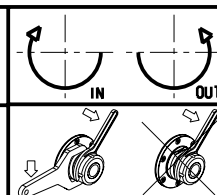

M.T. srl
Via Casino Albini 480
Tel. 0541/956034-957884
Fax 0541/956341
47842 S. GIOVANNI IN M. (RN)
e-mail: mtma@mtmarchetti.com
http://www.mtmarchetti.com

PRODUZIONE MODULI ROTANTI



PAGINA GDW 150-B-40

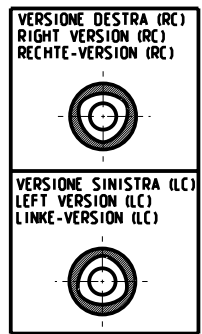
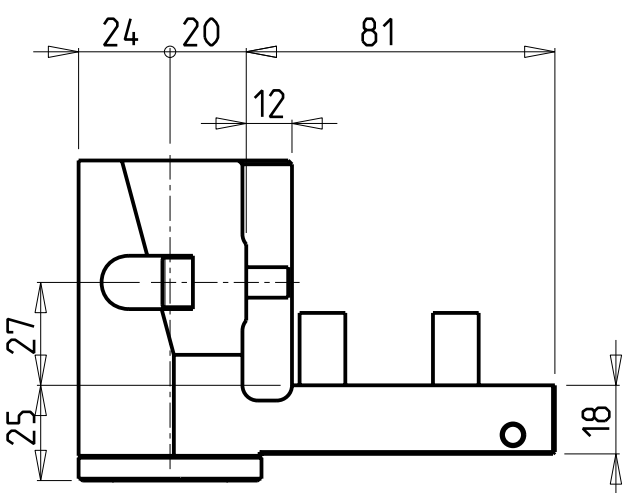
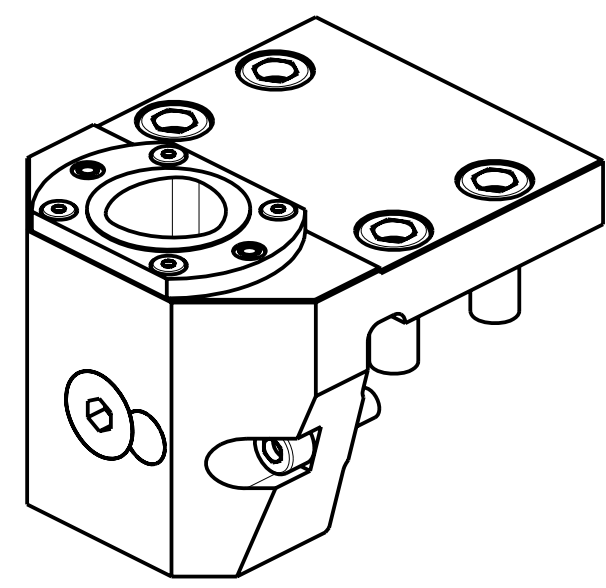
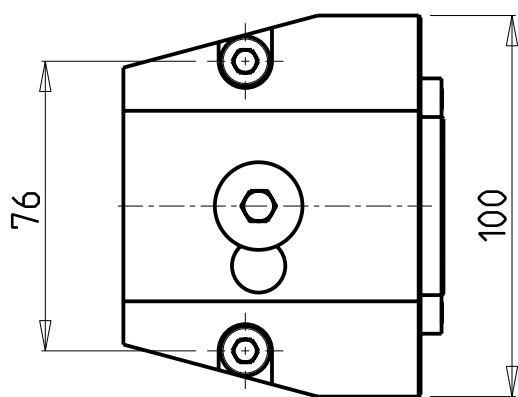
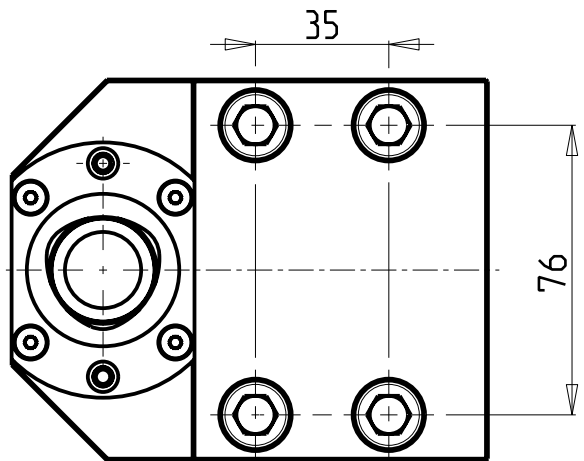

PER ORDINARE LA VERSIONE SX
 AGGIUNGERE "LC" AL CODICE IN TABELLA.
 ES: MNL0464010 DIVENTA MNL0464010LC

TO ORDER LEFT VERSION
 ADD A "LC" IN THE CODE-CHARTS.
 EXAMPLE: MNL0464010 BECOMES MNL0464010LC

UM DIE LINKE-VERSION ZU BESTELLEN, BEI DER
 ARTIKELBEZEICHNUNG "LC" HINZUFUEGEN.
 BEISPIEL: MNL0464010 WIRD DANN MNL0464010LC

Cod. MT	N°Utensili N° Tools N° Werkzeuge	Lubrificazione int. Coolant through Innenkuehlung	TAGLIA Size Masse
MSL0044010	1	X	C4

GOODWAY
 MOD: GS200/260/280 GA200
 PORTAUTENSILE RADIALE SINGOLO ARRETRATO COROMANT CAPTO®
 Radial rear-set single static tool COROMANT CAPTO®
 Radial Single-Werkzeughalter zurueckversetzt COROMANT CAPTO®

M.T. srl
 Via Casino Albini 480
 Tel. 0541/956034-957884
 Fax 0541/956341
 47842 S. GIOVANNI IN M. (RN)
 e-mail: mtma@mtmarchetti.com
 http://www.mtmarchetti.com

PRODUZIONE MODULI ROTANTI



PAGINA GDW 430-B-40

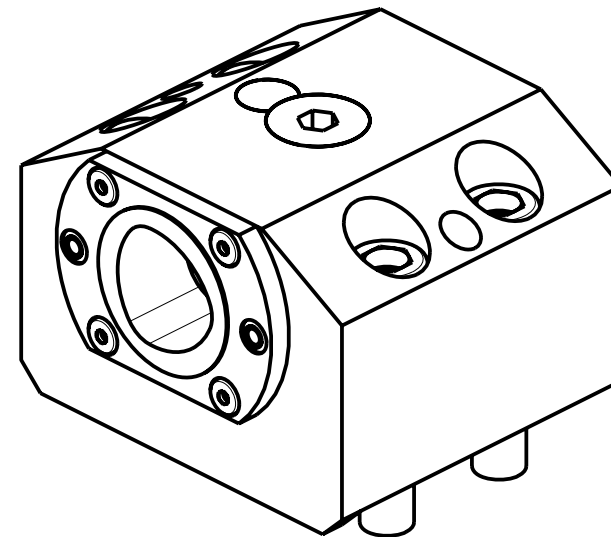
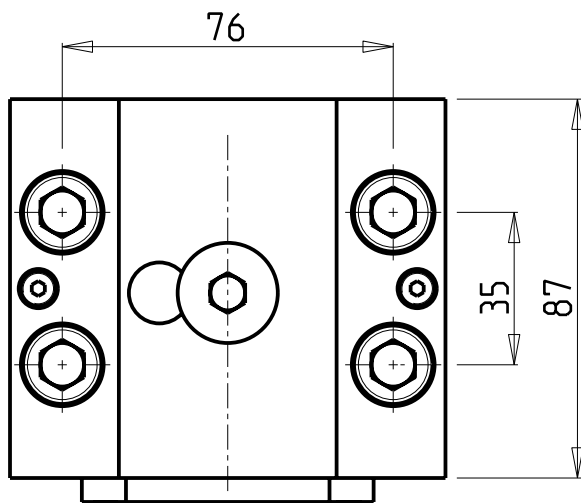
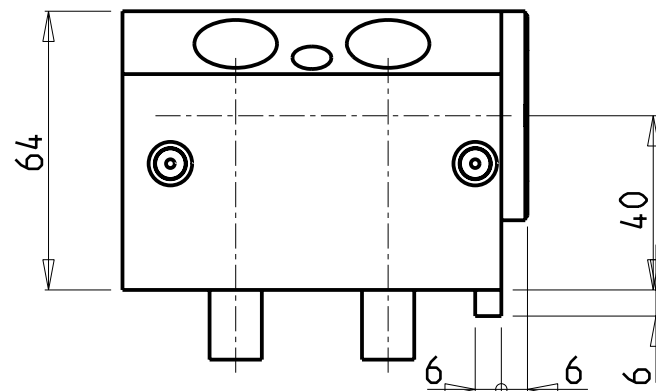
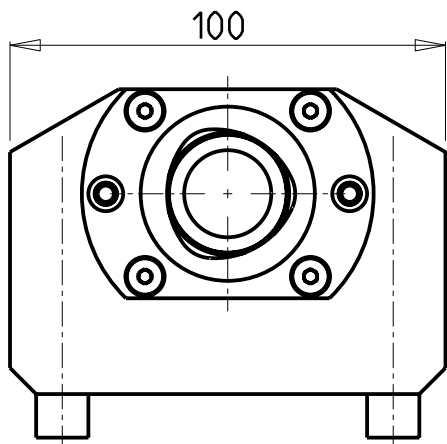

VERSIONE DESTRA (RC)
RIGHT VERSION (RC)
RECHTE-VERSION (RC)



VERSIONE SINISTRA (LC)
LEFT VERSION (LC)
LINKE-VERSION (LC)



PER ORDINARE LA VERSIONE SX
AGGIUNGERE "LC" AL CODICE IN TABELLA.
ES: MNL0464010 DIVENTA MNL0464010LC

TO ORDER LEFT VERSION
ADD A "LC" IN THE CODE-CHARTS.
EXAMPLE: MNL0464010 BECOMES MNL0464010LC

UM DIE LINKE-VERSION ZU BESTELLEN, BEI DER
ARTIKELBEZEICHNUNG "LC" HINZUFUEGEN.
BEISPIEL: MNL0464010 WIRD DANN MNL0464010LC

Cod. MT	N°Utensili N°Tools N°Werkzeuge	Lubrificazione int. Coolant through Innenkuehlung	TAGLIA Size Masse
MSL0034010	1	X	C4

GOODWAY
MOD: GS200/260/280 GA200

PORTAUTENSILE ASSIALE SINGOLO COROMANT CAPTO®
Axial single static tool COROMANT CAPTO®
Axial Single-Werkzeughalter COROMANT CAPTO®

M.T. srl

Via Casino Albini 480
Tel. 0541/956034-957884
Fax 0541/956341
47842 S. GIOVANNI IN M. (RN)
e-mail: mtma@mtmarchetti.com
http://www.mtmarchetti.com

PRODUZIONE MODULI ROTANTI



PAGINA GDW550-B-40