

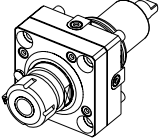

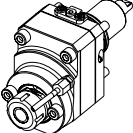

		PAGINA Page Seite
MODULO MOTORIZZATO ASSIALE VD140 Axial driven tool VD140 Axial angetriebenes Werkzeug VD140		KIA150.1.10
MODULO MOTORIZZATO ASSIALE BISPORGENTE ARRETRATO VD140 DIN5482 Axial rear-set opposite face twin driven tool VD140 DIN5482 Axial angetriebenes Werkzeug halb vorspringend zurueckversetzt VD140 DIN5482		KIA243.1.10

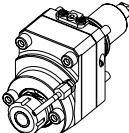

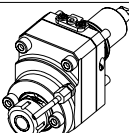
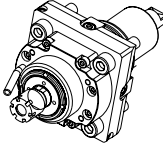
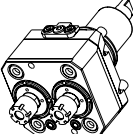
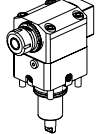

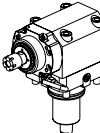
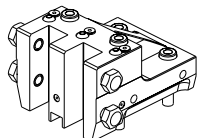
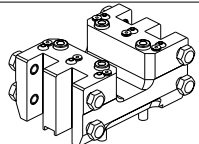
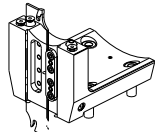
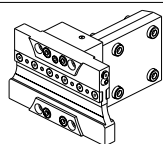
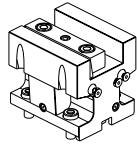
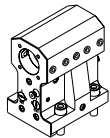
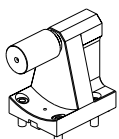

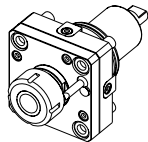
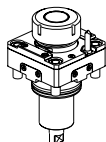
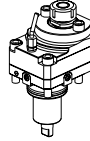
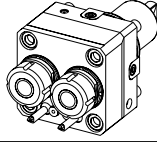
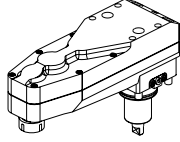
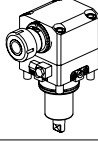

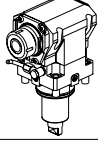
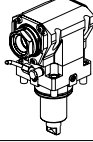
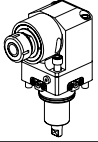
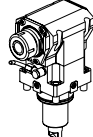





		PAGINA Page Seite
MODULO MOTORIZZATO RADIALE Radial driven tool Radial angetriebenes Werkzeug		KIA010.2.00
MODULO MOTORIZZATO RADIALE DISASSATO IN Z 36mm Radial driven tool re-directed in Z by 36mm Radial angetriebenes Werkzeug achsversetzt in Z um 36mm		KIA030.2.10
MODULO MOTORIZZATO RADIALE RIDOTTO I=2:1 DISASSATO IN Z 36mm Radial geared-down I=2:1 driven tool re-directed in Z by 36mm Radial angetriebenes Werkzeug untersetzt I=2:1 achsversetzt in Z um 36mm		KIA030.2.20
MODULO MOTOR. RADIALE MOLTIPLICATO I=1:2 DISASSATO IN Z 36mm Radial geared-up I=1:2 driven tool re-directed in Z by 36mm Radial angetriebenes Werkzeug uebersetzt I=1:2 achsversetzt in Z um 36mm		KIA030.2.30
MODULO MOTORIZZATO RADIALE MOLTIPLICATO I = 1:5,625 Radial geared-up I=1:5.625 driven tool Radial angetriebenes Werkzeug uebersetzt I=1:5.625		KIA060.2.00
MODULO MOTORIZZATO RADIALE 2 USCITE IN Y Radial single side I twin head driven tool in Y Radial angetriebenes Werkzeug 2 Ausgaenge in Y		KIA080.2.00
MODULO MOTORIZZATO ASSIALE Axial driven tool Axial angetriebenes Werkzeug		KIA150.2.30
MODULO MOTORIZZATO ASSIALE MOLTIPLICATO I = 1:2 Axial geared-up I=1:2 driven tool Axial angetriebenes Werkzeug uebersetzt I=1:2		KIA200.2.10
MODULO MOTORIZ ASSIALE MOLTIPLICATO I = 1:5,625 Axial geared-up I=1:5.625 driven tool Axial angetriebenes Werkzeug uebersetzt I=1:5.625		KIA210.2.10

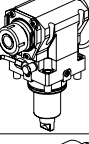

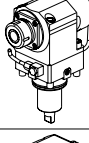

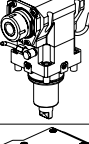
		PAGINA Page Seite
<p>MODULO MOTORIZZATO ASSIALE PER POLIGONATURA INTERNA Axial driven tool for internal polygon-making Axial angetriebenes Werkzeug fuer interne Facettierung</p>		KIA230.2.10
<p>MODULO MOTORIZZATO ASSIALE BISPORGENTE Axial opposite face twin driven tool Axial angetriebenes Werkzeug halb vorspringend</p>		KIA240.2.10
<p>MODULO MOTORIZZATO ASSIALE 2 USCITE IN Y Axial single side twin head driven tool in Y Axial angetriebenes Werkzeug 2 Ausgaenge in Y</p>		KIA260.2.10
<p>MODULO MOTORIZZATO ASSIALE 2 USCITE IN Y MOLTIPLICATO 1-1:2 Axial geared-up 1=1:2 single side twin head driven tool in Y Axial angetriebenes Werkzeug 2 Ausgaenge in Y uebersetzt 1=1:2</p>		KIA261.2.10 
<p>MODULO MOTORIZZATO ORIENTABILE ±90° ±90° adjustable angle driven tool Angetriebenes Werkzeug schwenkbar ±90°</p>		KIA335.2.10
<p>MODULO MOTORIZZATO ORIENTABILE ±90° MOLTIPLICATO 1-1:2 ±90° adjustable angle driven tool geared-up 1=1:2 Angetriebenes Werkzeug schwenkbar ±90° uebersetzt 1=1:2</p>		KIA336.2.10
<p>MODULO MOTORIZZATO PORTACREATORE Driven gear hobber Angetriebenes Zahnradwaelzfraes-Werkzeug</p>		KIA340.2.00
<p>MODULO MOTORIZZATO PORTACREATORE VERSIONE RADIALE Radial driven gear hobber Radial Angetriebenes Zahnradwaelzfraes-Werkzeug</p>		KIA340.2.30
<p>MODULO MOTORIZZATO STOZZATORE Slotting driven tool Keilnutenstossmaschine</p>		KIA360.2.00 

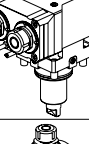
		PAGINA Page Seite
PORTAUTENSILE RADIALE SOVRAPPOSTO Radial single side twin static tool Radial Werkzeughalter ueberlagert		KIA442.2.00
PORTAUTENSILE RADIALE DOPPIO SOVRAPPOSTO Radial double side twin static tool Radial Doppel-Werkzeughalter ueberlagert		KIA463.2.00
PORTAUTENSILE RADIALE PER LAMA Radial blade holder Radial Abstechhalter		KIA510.2.00 NEW
PORTAUTENSILE PER LAMA DOPPIO Radial double blade holder Radial Doppel-Abstechhalter		KIA520.2.00
PORTAUTENSILE ASSIALE SINGOLO Axial single static tool Axial Single-Werkzeughalter		KIA552.2.00
PORTAUTENSILE ASSIALE PER BARENO Ø40mm / Ø1 1/2" H=100mm Axial single boring bar holder Ø40mm / Ø1 1/2" H=100mm Axial Bohrhalter Ø40mm / Ø1 1/2" H=100mm		KIA640.2.10
CONTROPUNTA PER CONTROMANDRINO Tailstock for subspindle Gegenspitz fuer Gegenspindel		KIA950.2.00

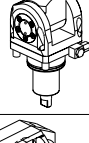
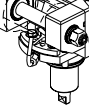
PORTAUTENSILE RADIALE SINGOLO ARRETRATO COROMANT CAPTO® Radial rear-set single static tool COROMANT CAPTO® Radial Single-Werkzeughalter zurueckversetzt COROMANT CAPTO®		KIA430.B.40
--	---	-------------

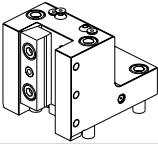
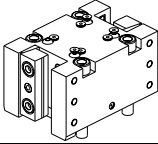
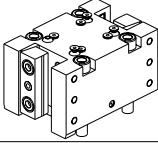
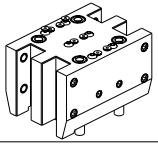
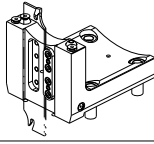

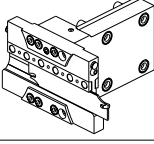
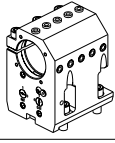
		PAGINA Page Seite
MODULO MOTORIZZATO RADIALE Radial driven tool Radial angetriebenes Werkzeug		KIA010.3.00
MODULO MOTORIZZATO RADIALE MAGGIORATO Radial reinforced driven tool Radial angetriebenes Werkzeug vergrößert		KIA020.3.00
MODULO MOTORIZZ. RADIALE MOLTIPLICATO I=1:2 DISASSATO IN Z 36mm Radial geared-up I=1:2 driven tool re-directed in Z by 36mm Radial angetriebenes Werkzeug uebersetzt I=1:2 achsversetzt in Z um 36mm		KIA030.3.30
MODULO MOTORIZZATO RADIALE 2 USCITE IN Y Radial single side twin head driven tool in Y Radial angetriebenes Werkzeug 2 Ausgaenge in Y		KIA080.3.00
MODULO MOTORIZZATO RADIALE ROVESCiato DISASSATO IN Z 250mm Radial inverted driven tool re-directed in Z by 250mm Radial angetriebenes Werkzeug umgekehrt achsversetzt in Z um 250mm		KIA120.3.10
MODULO MOTORIZZATO ASSIALE H=72mm Axial driven tool H=72mm Axial angetriebenes Werkzeug H=72mm		KIA150.3.10
MODULO MOTORIZZATO ASSIALE H=72mm Axial driven tool H=72mm Axial angetriebenes Werkzeug H=72mm		KIA150.3.11 NEW
MODULO MOTORIZZATO ASSIALE MTSK H=72mm Axial MTSK driven tool H=72mm Axial MTSK angetriebenes Werkzeug H=72mm		KIA150.3.11.K NEW
MODULO MOTORIZZATO ASSIALE H=85mm Axial driven tool H=85mm Axial angetriebenes Werkzeug H=85mm		KIA150.3.15 NEW
MODULO MOTORIZZATO ASSIALE MTSK H=85mm Axial MTSK driven tool H=85mm Axial MTSK angetriebenes Werkzeug H=85mm		KIA150.3.15.K NEW
MODULO MOTORIZZATO ASSIALE H=100mm Axial driven tool H=100mm Axial angetriebenes Werkzeug H=100mm		KIA150.3.20
MODULO MOTORIZZATO ASSIALE H=100mm Axial driven tool H=100mm Axial angetriebenes Werkzeug H=100mm		KIA150.3.21 NEW

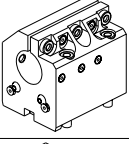
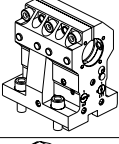
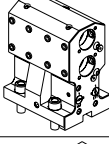
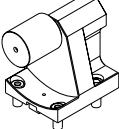
		PAGINA Page Seite
MODULO MOTORIZZATO ASSIALE MTSK H=100mm Axial MTSK driven tool H=100mm Axial MTSK angetriebenes Werkzeug H=100mm		KIA150.3.21.K 
MODULO MOTORIZZATO ASSIALE MOLTIPLICATO I=1:2 Axial geared-up I=1:2 driven tool Axial angetriebenes Werkzeug uebersetzt I=1:2		KIA200.3.20 
MODULO MOTORIZZATO ASSIALE BISPORGENTE H=72mm Axial opposite face driven tool H=72mm Axial angetriebenes Werkzeug halb vorspringend H=72mm		KIA240.3.10 
MODULO MOTORIZZATO ASSIALE BISPORGENTE H=85mm Axial opposite face twin driven tool H=85mm Axial angetriebenes Werkzeug halb vorspringend H=85mm		KIA240.3.15 
MODULO MOTORIZZATO ASSIALE BISPORGENTE H=100mm Axial opposite face twin driven tool H=100mm Axial angetriebenes Werkzeug halb vorspringend H=100mm		KIA240.3.20 
MODULO MOTORIZZATO ASSIALE BISPORGENTE H=100mm Axial opposite face twin driven tool H=100mm Axial angetriebenes Werkzeug halb vorspringend H=100mm		KIA240.3.21 
MODULO MOTORIZZATO ASSIALE 2 USCITE IN Y Axial single side twin head driven tool in Y Axial angetriebenes Werkzeug 2 Ausgaenge in Y		KIA260.3.10 
MODULO MOTORIZZATO ORIENTABILE 0-90° 0-90° adjustable angle driven tool Angetriebenes Werkzeug schwenkbar 0-90°		KIA330.3.00
MODULO MOTORIZZATO PORTACREATORE Driven gear hobber Angetriebenes Zahnradwaelzfraes-Werkzeug		KIA340.3.00

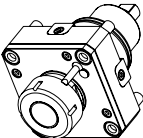
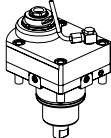
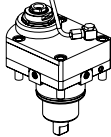
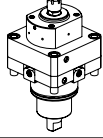
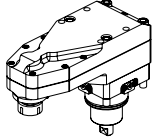
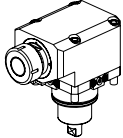
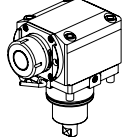
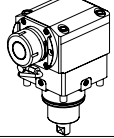
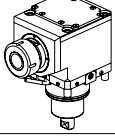
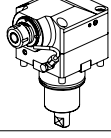
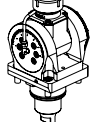
		PAGINA Page Seite
PORTAUTENSILE RADIALE SINGOLO Radial single static tool Radial Single-Werkzeughalter		KIA423.3.00
PORTAUTENSILE RADIALE DOPPIO Radial double static tool Radial Doppel-Werkzeughalter		KIA453.3.00
PORTAUTENSILE RADIALE DOPPIO Radial double static tool Radial Doppel-Werkzeughalter		KIA453.3.10
PORTAUTENSILE RADIALE DOPPIO SOVRAPPOSTO Radial double side twin static tool Radial Doppel-Werkzeughalter ueberlagert		KIA463.3.00
PORTAUTENSILE RADIALE PER LAMA Radial blade holder Radial Abstechhalter		KIA510.3.00 
PORTAUTENSILE PER LAMA DOPPIO Radial double blade holder Radial Doppel-Abstechhalter		KIA520.3.00
PORTAUTENSILE ASSIALE PER BARENO Ø60mm H=100mm Axial single boring bar holder Ø60mm H=100mm Axial Bohrhalter Ø60mm H=100mm		KIA590.3.20 
PORTAUTENSILE ASSIALE PER BARENO Ø 40mm/Ø1 1/2"/Ø 50mm/Ø 2" H=72mm Axial single boring bar holder Ø40mm/Ø1 1/2"/Ø50mm/Ø2" H=72mm Axial Bohrhalter Ø40mm/Ø1 1/2"/Ø50mm/Ø2" H=72mm		KIA610.3.20
PORTAUTENSILE ASSIALE PER BARENO Ø40mm H=100mm Axial single boring bar holder Ø40mm H=100mm Axial Bohrhalter Ø40mm H=100mm		KIA640.3.20
PORTAUTENSILE ASSIALE PER BARENO 2 POSIZIONI Ø32mm Axial double boring bar holder Ø32mm Axial Bohrhalter 2 Positionen Ø32mm		KIA862.3.00
CONTROPUNTA PER CONTROMANDRINO Tailstock for subspindle Gegenspitz fuer Gegenspindel		KIA950.3.00

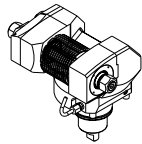
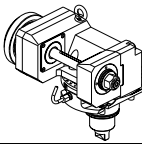
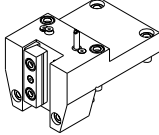
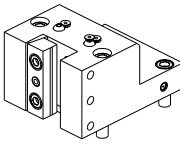
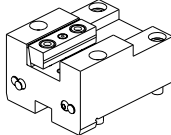
		PAGINA Page Seite
MODULO MOTORIZZATO RADIALE Radial driven tool Radial angetriebenes Werkzeug		KIA010.4.00
MODULO MOTORIZZATO RADIALE DISASSATO IN Z 47.5mm Radial driven tool re-directed in Z by 47.5mm Radial angetriebenes Werkzeug achsversetzt in Z um 47.5mm		KIA033.4.10
MODULO MOTORIZZ. RADIALE MOLTIPLICATO I=1:2 DISASSATO IN Z 47.5mm Radial geared-up I=1:2 driven tool re-directed in Z by 47.5mm Radial angetriebenes Werkzeug uebersetzt I=1:2 achsversetzt in Z um 47.5mm		KIA033.4.30
MODULO MOTORIZZATO RADIALE MOLTIPLICATO I=1:4 Radial geared-up I=1:4 driven tool Radial angetriebenes Werkzeug uebersetzt I=1:4		KIA058.4.00
MODULO MOTORIZZATO RADIALE ROVESCiato DISASSATO IN Z 187,5mm Radial inverted driven tool re-directed in Z by 187.5mm Radial angetriebenes Werkzeug ungekehrt achsversetzt in Z um 187.5mm		KIA120.4.10
MODULO MOTORIZZATO ASSIALE H=60mm Axial driven tool H=60mm Axial angetriebenes Werkzeug H=60mm		KIA150.4.10 NEW
MODULO MOTORIZZATO ASSIALE MAGGIORATO H=60mm Axial reinforced driven tool H=60mm Axial angetriebenes Werkzeug vergroesset H=60mm		KIA170.4.10 NEW
MODULO MOTORIZZATO ASSIALE MAGGIORATO Axial reinforced driven tool Axial angetriebenes Werkzeug vergroesset		KIA170.4.20
MODULO MOTORIZZATO ASSIALE RIDOTTO I=2:1 Axial geared-down I=2:1 driven tool Axial angetriebenes Werkzeug untersetzt I=2:1		KIA190.4.10 NEW
MODULO MOTORIZZATO ASSIALE MOLTIPLICATO I=1:3 Axial geared-up I=1:3 driven tool Axial angetriebenes Werkzeug uebersetzt I=1:3		KIA205.4.10 NEW
MODULO MOTORIZZATO ORIENTABILE +/-90° +/-90° adjustable angle driven tool Angetriebenes Werkzeug schwenkbar +/-90°		KIA339.4.00 NEW

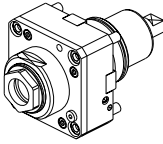
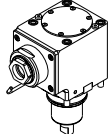
		PAGINA Page Seite
<p>MODULO MOTORIZZATO PORTACREATORE MAGGIORATO Reinforced driven gear hobber Angetriebenes Zahnradwaelzfraes-Werkzeug vergroessert</p>		KIA340.4.60
<p>MODULO MOTORIZZATO PORTACREATORE (TAGLIA GRANDE) Driven gear hobber (big size) Angetriebenes Zahnradwaelzfraes-Werkzeug (grosse version)</p>		KIA340.4.80 NEW
<p>PORTAUTENSILE RADIALE SINGOLO Radial single static tool Radial Single-Werkzeughalter</p>		KIA423.4.00
<p>PORTAUTENSILE RADIALE SINGOLO Radial single static tool Radial Single-Werkzeughalter</p>		KIA423.4.01 NEW
<p>PORTAUTENSILE ASSIALE SINGOLO Axial single static tool Axial Single-Werkzeughalter</p>		KIA552.4.00

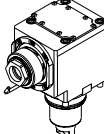
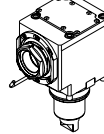
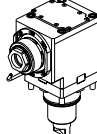
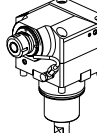
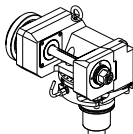
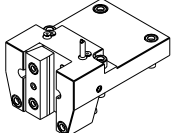
		PAGINA Page Seite
MODULO MOTORIZZATO RADIALE Radial driven tool Radial angetriebenes Werkzeug		KIA010.5.00
MODULO MOTORIZZATO ASSIALE H=85mm Axial driven tool H=85mm Axial angetriebenes Werkzeug H=85mm		KIA150.5.10
MODULO MOTORIZZATO ASSIALE H=110mm Axial driven tool H=110mm Axial angetriebenes Werkzeug H=110mm		KIA150.5.20 NEW
MODULO MOTORIZZATO ASSIALE RIDOTTO I=2:1 Axial geared-down I=2:1 driven tool Axial angetriebenes Werkzeug untersetzt I=2:1		KIA190.5.10 NEW
MODULO MOTORIZZATO ASSIALE MTSK RIDOTTO I=2:1 Axial MTSK geared-down I=2:1 driven tool Axial MTSK angetriebenes Werkzeug untersetzt I=2:1		KIA190.5.10.K NEW
MODULO MOTORIZZATO ASSIALE RIDOTTO I=2:1 H=110mm Axial geared-down I=2:1 driven tool H=110mm Axial angetriebenes Werkzeug untersetzt I=2:1 H=110mm		KIA190.5.20 NEW
MODULO MOTORIZZATO ASSIALE MTSK RIDOTTO I=2:1 H=110mm Axial MTSK geared-down I=2:1 driven tool H=110mm Axial MTSK angetriebenes Werkzeug untersetzt I=2:1 H=110mm		KIA190.5.20.K NEW
MODULO MOTORIZZATO ASSIALE MOLTIPLICATO I=1:3 Axial geared-up I=1:3 driven tool Axial angetriebenes Werkzeug uebersetzt I=1:3		KIA205.5.10
MODULO MOTORIZZATO ORIENTABILE +/-90° +/-90° adjustable angle driven tool Angetriebenes Werkzeug schwenkbar +/-90°		KIA339.5.00 NEW
MODULO MOTORIZZATO PORTACREATORE MAGGIORATO Reinforced driven gear hobber Angetriebenes Zahnradwaelzfraes-Werkzeug vergroessert		KIA340.5.60
MODULO MOTORIZZATO PORTACREATORE (TAGLIA GRANDE) Driven gear hobber (big size) Angetriebenes Zahnradwaelzfraes-Werkzeug (grosse version)		KIA340.5.80 NEW
PORTAUTENSILE RADIALE SINGOLO Radial single static tool Radial Single-Werkzeughalter		KIA423.5.00

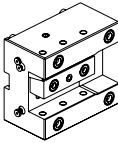
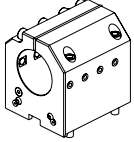
		PAGINA Page Seite
PORTAUTENSILE ASSIALE SINGOLO Axial single static tool Axial Single-Werkzeughalter		KIA552.5.00
PORTAUTENSILE ASSIALE PER BARENO Ø80mm / Ø3" H=85mm Axial single boring bar holder Ø80mm / Ø3" H=85mm Axial Bohrhalter Ø80mm / Ø3" H=85mm		KIA580.5.20

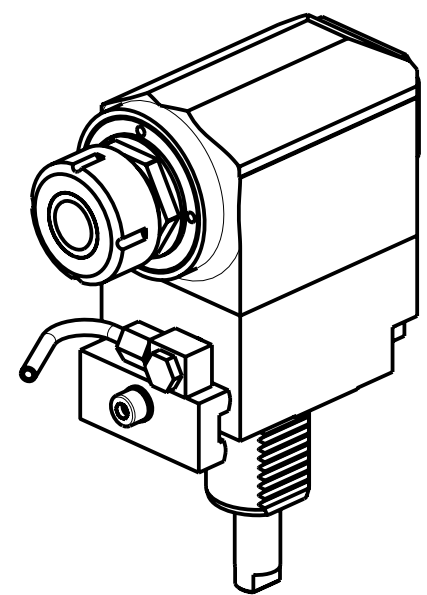
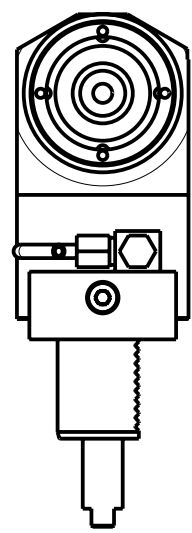
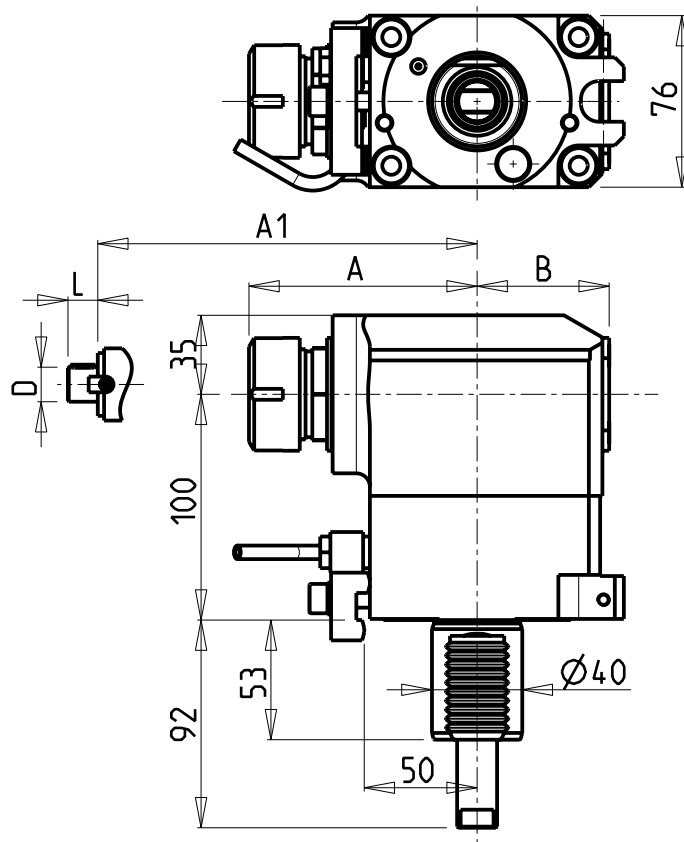

ATTENZIONE - ATTENTION - ACHTUNG

- Per lo smontaggio degli utensili utilizzare sempre la chiave di contrasto come indicato nel manuale d'uso.
- For disassembly of the tools use always the contrast key as mentioned in the user instructions.
- Fuer das Abmontieren der Werkzeuge immer den Gegenschlüssel benutzen wie in der Bedienungsanleitung erwäehnt.

Cod. MT	Mandrino Spindle Spindel	I	RPM	Coppia Max Max Torque Max Drehmoment	Lubrificazione int. Coolant through Innenkuehlung	Lubrificazione est. Ext. coolant Aussenkuehlung	A	A1	B	D	L	CHIAVI NON INCLUSE Keys not included Schlüssel nicht einbegriffen	
253KIA_R32_40A00	ER32	1:1	4000	70Nm		X	101.1	-	58.5	-	-	CHUB41	CHSTER32
253KIA_R32_40A10	ER32	1:1	4000	70Nm	P=70bar	X	101.1	-	82	-	-	CHUB41	CHSTER32
253KIA_R22_40A00	Ø22x19	1:1	4000	70Nm		X	-	78.5	58.5	22	19	CHUB41	CH_VTCROCE_M10
253KIA_R27_40A00	Ø27x21	1:1	4000	70Nm		X	-	78.5	58.5	27	21	CHUB41	CH_VTCROCE_M12

HYUNDAI-KIA (WIA)
 MOD: SKT28LM (L280LM)
 MODULO MOTORIZZATO ASSIALE VDI40
 Axial driven tool VDI40
 Axial angetriebenes Werkzeug VDI40

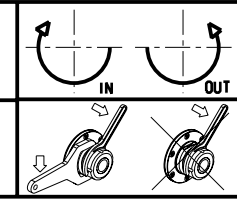

M.T. srl
 Via Casino Albini 480
 Tel. 0541/956034-957884
 Fax 0541/956341
 47842 S. GIOVANNI IN M. (RN)
 e-mail: mtma@mtmarchetti.com
 http://www.mtmarchetti.com

PRODUZIONE MODULI ROTANTI



PAGINA KIA150-1-10

ATTENZIONE - ATTENTION - ACHTUNG

- Per lo smontaggio degli utensili utilizzare sempre la chiave di contrasto come indicato nel manuale d'uso.
- For disassembly of the tools use always the contrast key as mentioned in the user instructions.
- Fuer das Abmontieren der Werkzeuge immer den Gegenschlüssel benutzen wie in der Bedienungsanleitung erwäehnt.

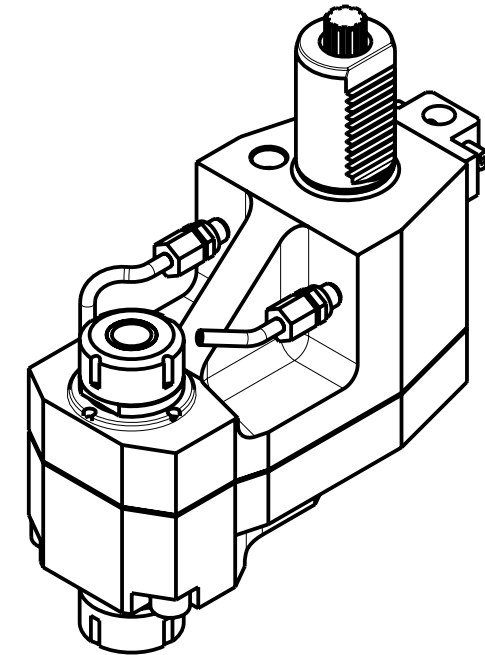
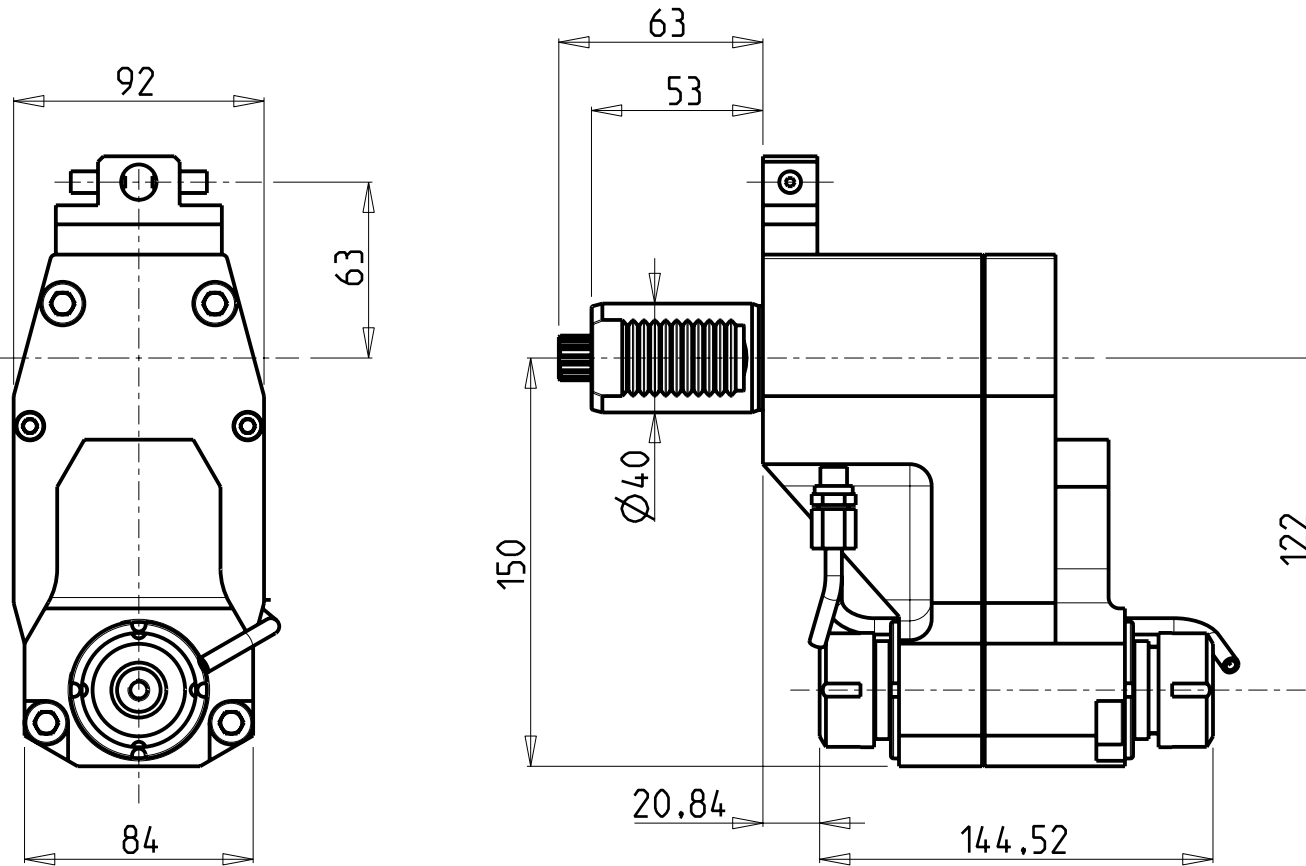

Cod. MT	Mandrino Spindle Spindel	I	RPM	Coppia Max Max Torque Max Drehmoment	Lubrificazione est. Ext. coolant Aussenkuehlung	CHIAVI NON INCLUSE Keys not included Schluessel nicht einbegriffen	
254KIA_A25_40D00	ER25+ER25	1:1	4000	70Nm	X	CHUB36	CHSTER25

HYUNDAI-KIA (WIA)

MOD: SKT15LMS (L150LMSA) - SKT21LMS (L210LMSA)

MODULO MOTORIZZATO ASSIALE BISPORGENTE ARRETRATO VD140 DIN5482

Axial rear-set opposite face twin driven tool VD140 DIN5482

Axial angetriebenes Werkzeug halb vospringend zurueckversetzt VDI40 DIN5482

M.T. srl

Via Casino Albini 480
Tel. 0541/956034-957884
Fax 0541/956341
47842 S. GIOVANNI IN M. (RN)
e-mail: mtma@mtmarchetti.com
http://www.mtmarchetti.com

PRODUZIONE MODULI ROTANTI



PAGINA KIA243-1-10

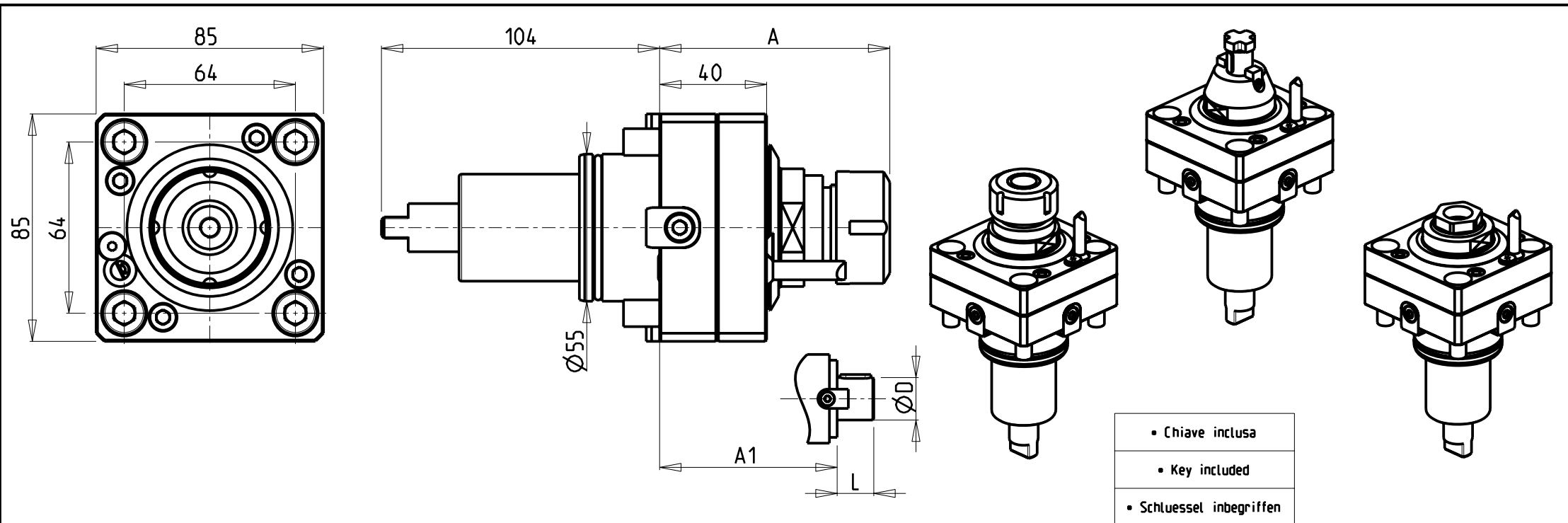

Cod. MT	Mandrino Spindle Spindel	I	RPM	Coppia Max Max Torque Max Drehmoment	Lubrificazione int. Coolant through Innenkuehlung	Lubrificazione est. Ext. coolant Aussenkuehlung	A	A1	D	L	CHIAVI NON INCLUSE Keys not included Schluessel nicht einbegriffen
0271325	ER25	1:1	6000	50Nm		X	86.06	-	-	-	CHSTER25 CHUB40 o 0270018
0270225	ER25	1:1	6000	50Nm	P=30bar	X	86.06	-	-	-	CHSTER25 CHUB40 o 0270018
0271525	ER A 25	1:1	6000	50Nm		X	63.03	-	-	-	CHUB27 CHUB40 o 0270018
0271025	ER A 25	1:1	6000	50Nm	P=30bar	X	63.03	-	-	-	CHUB27 CHUB40 o 0270018
0272232	ER32	1:1	6000	50Nm		X	85.06	-	-	-	CHSTER32 CHUB40 o 0270018
0272332	ER32	1:1	6000	50Nm	P=30bar	X	85.16	-	-	-	CHSTER32 CHUB40 o 0270018
0271617	Ø16x17	1:1	6000	50Nm		X	-	70	16	17	CH_VTCROCE_M08 * CHUB40 o 0270018
0272219	Ø22x19	1:1	6000	50Nm		X	-	70	22	19	CH_VTCROCE_M10 * CHUB40 o 0270018

HYUNDAI-KIA (WIA)

MOD: SKT160TTMS/TTSY (LM1600TTMS/TTSY) - SKT180TTMS/TTSY (LM1800TTMS/TTSY) (L230LMSA)

MODULO MOTORIZZATO RADIALE

Radial driven tool

Radial angetriebenes Werkzeug

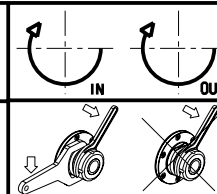

M.T. srl

Via Casino Albini 480
Tel. 0541/956034-957884

Fax 0541/956341

47842 S. GIOVANNI IN M. (RN)

e-mail: mtma@mtmarchetti.com

http://www.mtmarchetti.com

PRODUZIONE MODULI ROTANTI



PAGINA KIA010-2-00

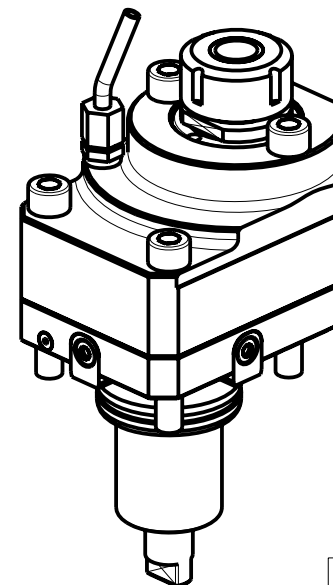
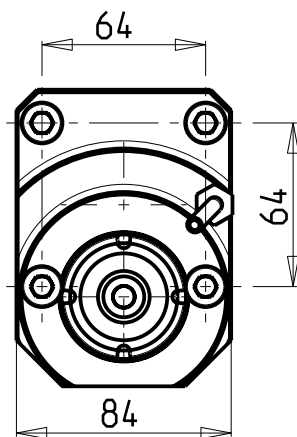
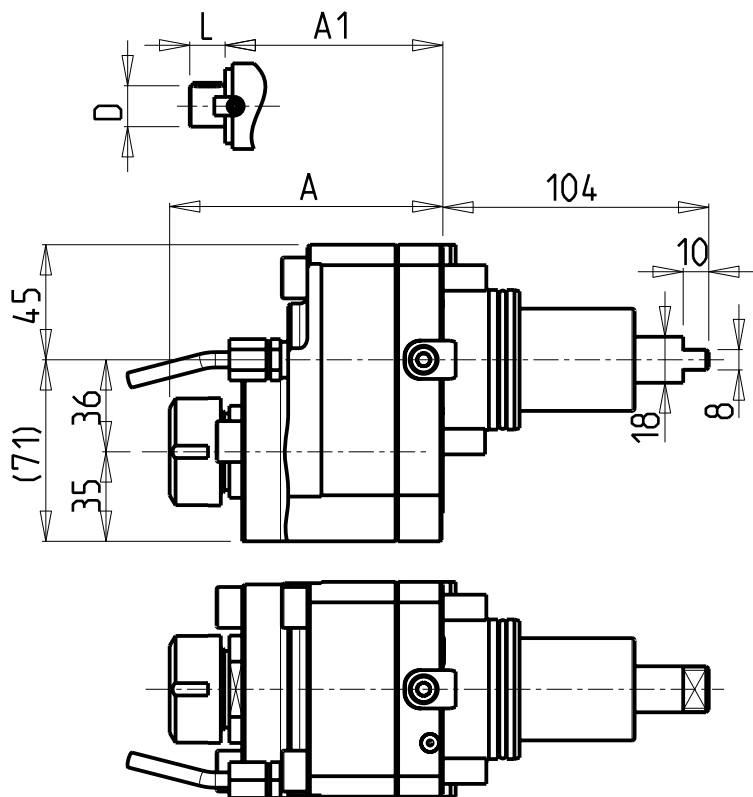

- Chiave inclusa
- Key included
- Schluessel inbegriffen

Cod. MT	Mandrino Spindle Spindel	I	RPM	Coppia Max Max Torque Max Drehmoment	Reversibile lato mandrino/contromandrino Reversible sub/main spindle side Umkehrbare Spindel-seite/ Gegenspindel-seite	Lubrificazione est. Ext. coolant Aussenkuehlung	A	A1	D	L	CHIAVI NON INCLUSE Keys not included Schluessel nicht einbegriffen	
											CH_VTCROCE_M08	MNL0210007
0720025	ER25	1:1	6000	50Nm	X	X	106.86	-	-	-	CHSTER25	MNL0210007
0720032	ER32	1:1	6000	50Nm	X	X	120.56	-	-	-	CHSTER32	MNL0210007
0720016	Ø16x17	1:1	6000	50Nm	X	X	-	88.5	16	17	CH_VTCROCE_M08	MNL0210007
0720022	Ø22x19	1:1	6000	50Nm	X	X	-	90.5	22	19	CH_VTCROCE_M10	MNL0210007
0720027	Ø27x21	1:1	6000	50Nm	X	X	-	92.5	27	21	CH_VTCROCE_M12	MNL0210007

HYUNDAI-KIA (WIA)

MOD: SKT160TTMS/TTSY (LM1600TTMS/TTSY) - SKT180TTMS/TTSY (LM1800TTMS/TTSY) (L230LMSA)

MODULO MOTORIZZATO RADIALE DISASSATO IN Z 36mm

Radial driven tool re-directed in Z by 36mm

Radial angetriebenes Werkzeug achsversetzt in Z um 36mm

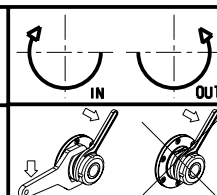

M.T. srl

Via Casino Albini 480
Tel. 0541/956034-957884
Fax 0541/956341

47842 S. GIOVANNI IN M. (RN)
e-mail: mtma@mtmarchetti.com
http://www.mtmarchetti.com

PRODUZIONE MODULI ROTANTI



PAGINA KIA030-2-10

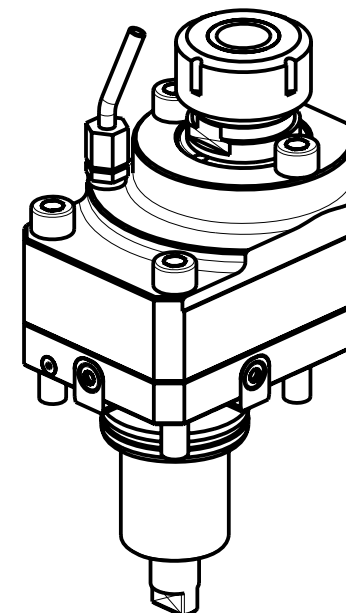
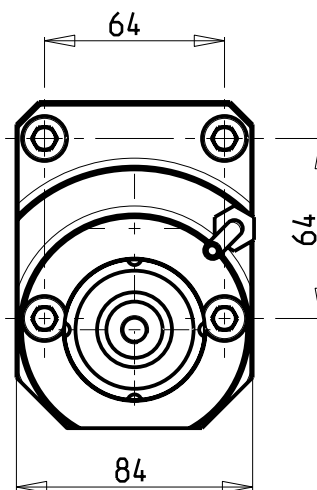
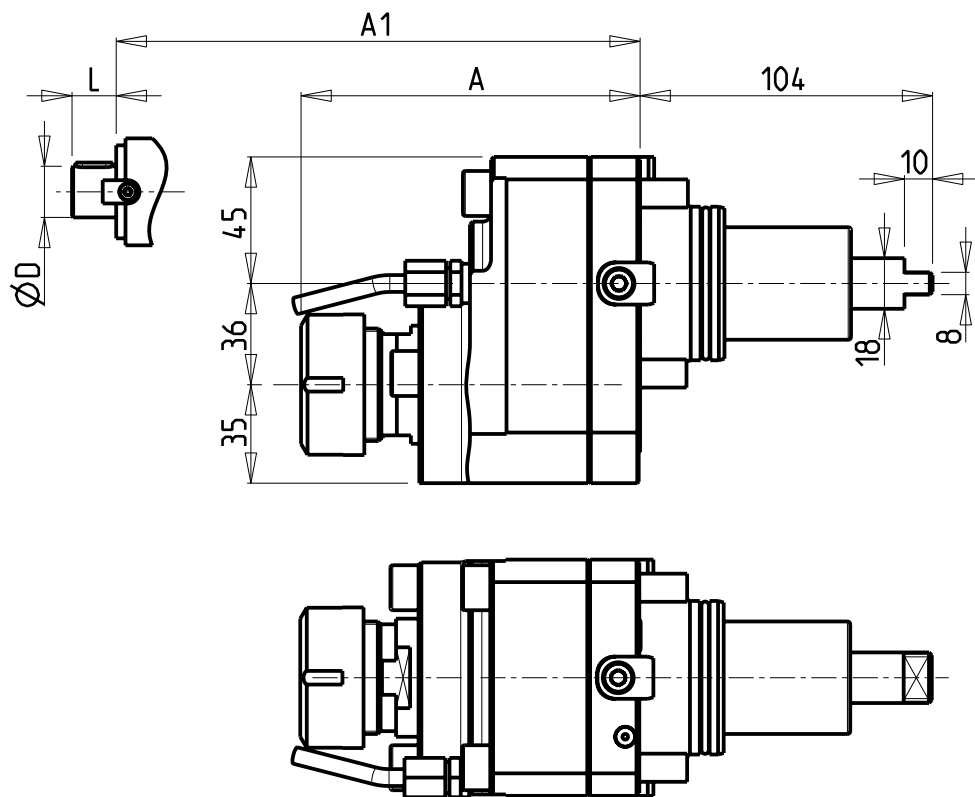

- Chiave inclusa
- Key included
- Schluessel inbegriffen

Cod. MT	Mandrino Spindel Spindel	I	RPM	Coppia Max Max Torque Max Drehmoment	Reversibile lato mandrino/contromandrino Reversible sub/main spindle side Umkehrbare Spindelsetseite/ Gegenspindelsetseite	Lubrificazione est. Ext. coolant Aussenkuehlung	A	A1	D	L	CHIAVI NON INCLUSE Keys not included Schluessel nicht einbegriffen	
0722132	ER32	2:1	3000	65Nm	X	X	120.56	-	-	-	CHSTER32	MNL0210007
0722116	Ø16x17	2:1	3000	65Nm	X	X	-	88.5	16	17	CH_VTCROCE_M08	MNL0210007
0722122	Ø22x19	2:1	3000	65Nm	X	X	-	90.5	22	19	CH_VTCROCE_M10	MNL0210007
0722127	Ø27x21	2:1	3000	65Nm	X	X	-	92.5	27	21	CH_VTCROCE_M12	MNL0210007

HYUNDAI-KIA (WIA)

MOD: SKT160TTMS/TTSY (LM1600TTMS/TTSY) - SKT180TTMS/TTSY (LM1800TTMS/TTSY) (L230LMSA)

MODULO MOTORIZZATO RADIALE RIDOTTO I=2:1 DISASSATO IN Z 36mm

Radial geared-down I=2:1 driven tool re-directed in Z by 36mm

Radial angetriebenes Werkzeug untersetzt I=2:1 achsversetzt in Z um 36mm

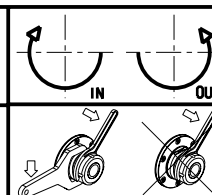

M.T. srl

Via Casino Albini 480
Tel. 0541/956034-957884
Fax 0541/956341

47842 S. GIOVANNI IN M. (RN)
e-mail: mtma@mtmarchetti.com
http://www.mtmarchetti.com

PRODUZIONE MODULI ROTANTI



PAGINA KIA030-2-20

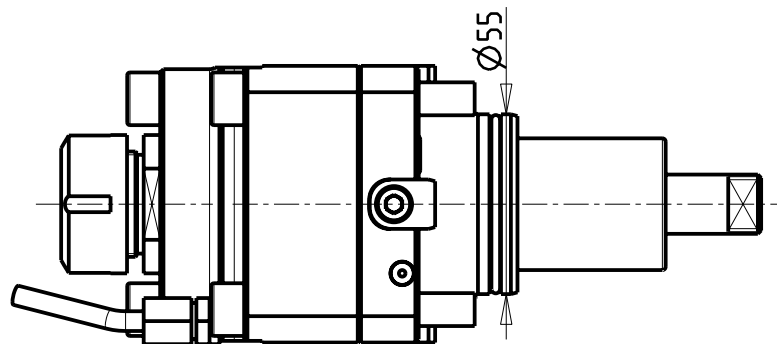
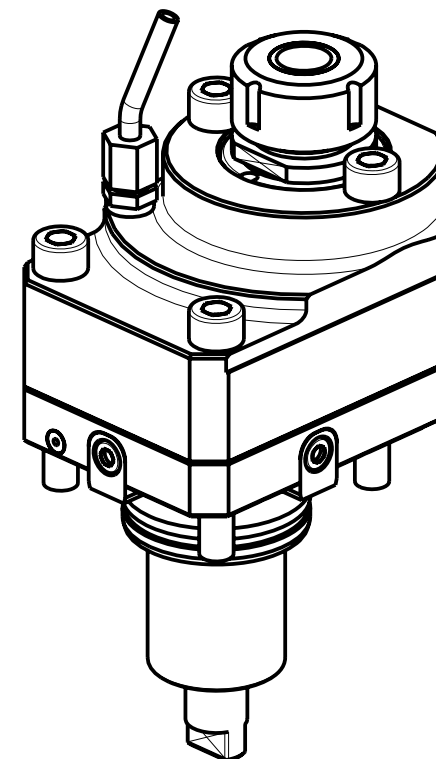
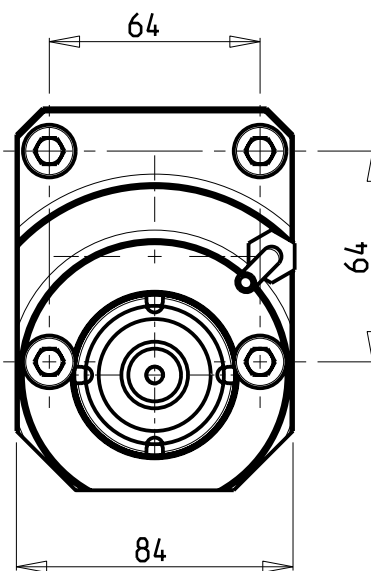
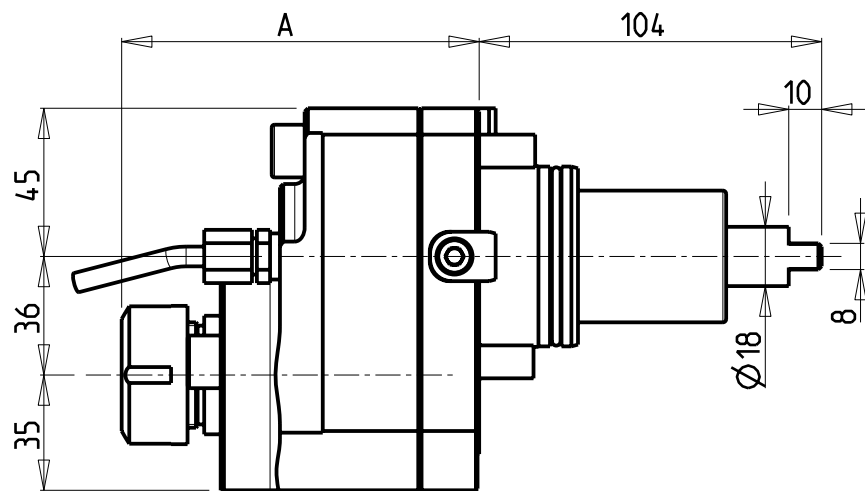

Cod. MT	Mandrino Spindle	I	RPM	Coppia Max Max Torque Max Drehmoment	Reversibile lato mandrino/contromandrino Reversible sub/main spindle side Umkehrbare Spindel-seite/ Gegenspindel-seite	Lubrificazione est. Ext. coolant Aussenkuehlung	A	CHIAVI NON INCLUSE Keys not included Schluessel nicht einbegriffen
0721225	ER25	1:2	12000	30Nm	X	X	108.56	CHSTER25 MNL0210007

HYUNDAI-KIA (WIA)

MOD: SKT160TTMS/TTSY (LM1600TTMS/TTSY) - SKT180TTMS/TTSY (LM1800TTMS/TTSY) (L230LMSA)

MODULO MOTORIZZATO RADIALE MOLTIPLICATO I=1:2 DISASSATO IN Z 36mm

Radial geared-up I=1:2 driven tool re-directed in Z by 36mm

Radial angetriebenes Werkzeug uebersezt I=1:2 achsversetzt in Z um 36mm

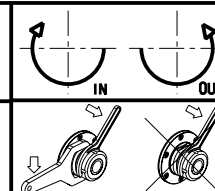

M.T. srl

Via Casino Albini 480
Tel. 0541/956034-957884
Fax 0541/956341

47842 S. GIOVANNI IN M. (RN)
e-mail: mtma@mtmarchetti.com
http://www.mtmarchetti.com

PRODUZIONE MODULI ROTANTI



PAGINA KIA030-2-30

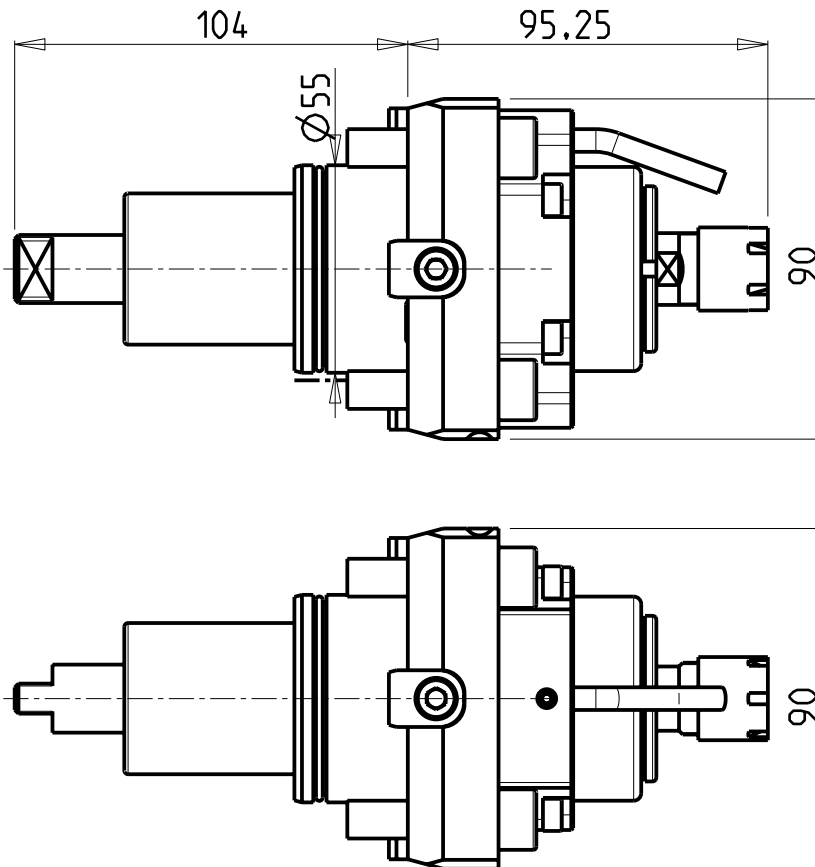
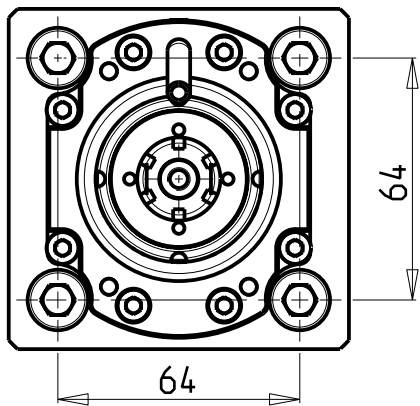

ATTENZIONE - ATTENTION - ACHTUNG

- Per lo smontaggio degli utensili utilizzare sempre la chiave di contrasto come indicato nel manuale d'uso.
- For disassembly of the tools use always the contrast key as mentioned in the user instructions.
- Fuer das Abmontieren der Werkzeuge immer den Gegenschlüssel benutzen wie in der Bedienungsanleitung erwäehnt.

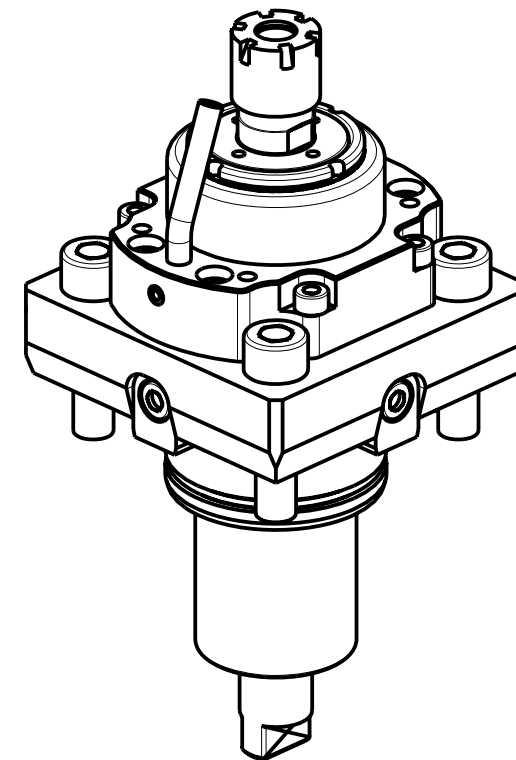

ATTENZIONE - ATTENTION - ACHTUNG

- PRIMA DI UTILIZZARE IL MOTORIZZATO CONSULTARE LE ISTRUZIONI ALLEGATE!
- BEFORE USING THE DRIVEN TOOL, PLEASE CHECK THE ENCLOSED INSTRUCTION SHEET!
- VOR DER BENUTZUNG DES ANGETRIEBENEN WERKZEUGES, DIE BEILIEGENDEN INSTRUKTIONEN DURCHLESEN!

Cod. MT	Mandrino Spindle Spindel	I	RPM	Coppia Max Max Torque Max Drehmoment	Lubrificazione int. Coolant through Innenkuehlung	Lubrificazione est. Ext. coolant Ausseenkuehlung	A	CHIAVI INCLUDE Keys included Schluessel einbegriffen	
DW 00600116	ER16	1:5.625	22500	6Nm		X	95.25	CHMNER16	CHUB17
DW 00600111	ER11	1:5.625	22500	6Nm	P=30bar	X	107.45	CHMNER11	CHUB11

HYUNDAI-KIA (WIA)

MOD: SKT160TTMS/TTSY (LM1600TTMS/TTSY) - SKT180TTMS/TTSY (LM1800TTMS/TTSY) (L230LMSA)

MODULO MOTORIZZATO RADIALE MOLTIPLICATO I = 1:5.625

Radial geared-up I=1:5.625 driven tool

Radial angetriebenes Werkzeug uebersetzt I=1:5.625

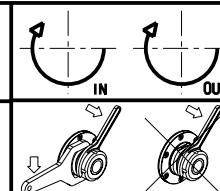

M.T. srl

Via Casino Albini 480
Tel. 0541/956034-957884
Fax 0541/956341

47842 S. GIOVANNI IN M. (RN)
e-mail: mtma@mtmarchetti.com
http://www.mtmarchetti.com

PRODUZIONE MODULI ROTANTI



PAGINA KIA060-2-00

ATTENZIONE - ATTENTION - ACHTUNG

- Per lo smontaggio degli utensili utilizzare sempre la chiave di contrasto come indicato nel manuale d'uso.
- For disassembly of the tools use always the contrast key as mentioned in the user instructions.
- Fuer das Abmontieren der Werkzeuge immer den Gegenschlüssel benutzen wie in der Bedienungsanleitung erwäehnt.

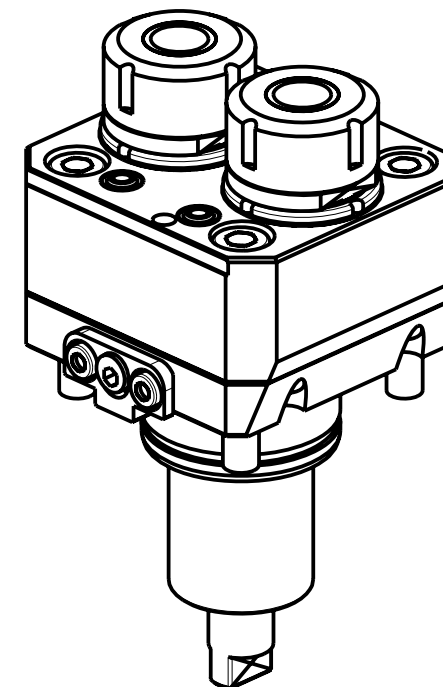
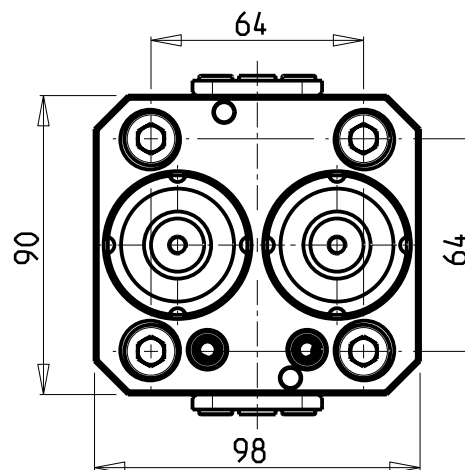
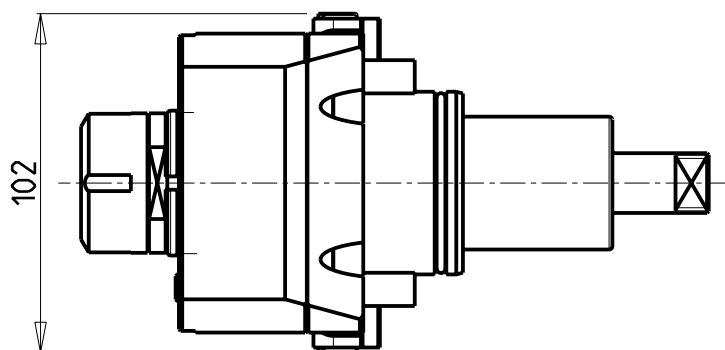
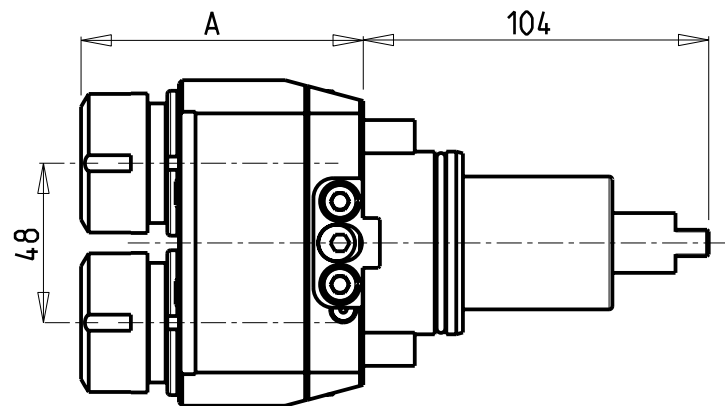

Cod. MT	Mandrino Spindle Spindel	I	RPM	Coppia Max Max Torque Max Drehmoment	Lubrificazione est. Ext. coolant Ausseinkuehlung	A	CHIAVI NON INCLUSE Keys not included Schlüssel nicht einbegriffen	
0730016X2	ER16	1:1	6000	30Nm	X	84.5	CHMNER16	CHUB17
0730025X2	ER25	1:1	6000	30Nm	X	85	CHSTER25	MNL0210007

HYUNDAI-KIA (WIA)

MOD: SKT160TTMS/TTSY (LM1600TTMS/TTSY) - SKT180TTMS/TTSY (LM1800TTMS/TTSY) (L230LMSA)

MODULO MOTORIZZATO RADIALE 2 USCITE IN Y
Radial single side twin head driven tool in Y
Radial angetriebenes Werkzeug 2 Ausgaenge in Y

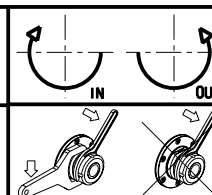

M.T. srl

Via Casino Albini 480
Tel. 0541/956034-957884
Fax 0541/956341

47842 S. GIOVANNI IN M. (RN)
e-mail: mtma@mtmarchetti.com
http://www.mtmarchetti.com

PRODUZIONE MODULI ROTANTI



PAGINA KIA080-2-00

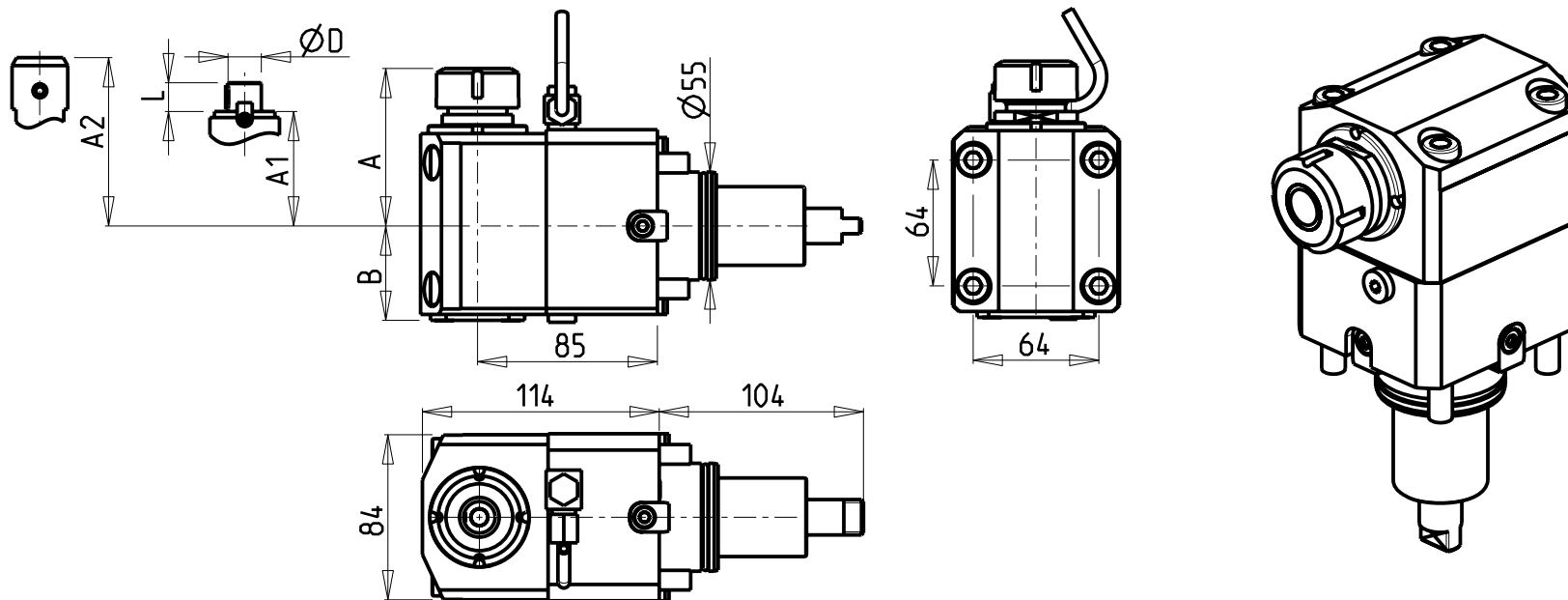

- Chiave inclusa
- Key included
- Schluessel inbegriffen

Cod. MT	Mandrino Spindle Spindel	I	RPM	Coppia Max Max Torque Max Drehmoment	Reversibile lato mandrino/contromandrino Reversible sub/main spindle side Umkehrbare Spindel-seite/ Gegenspindel-seite	Lubr.interna Coolant through Innenkuehlung	Lubr. esterna Ext. coolant Aussenkuehlung	A	A1	A2	B	D	L	CHIAVI NON INCLUSE Keys not included Schluessel nicht einbegriffen
DW 00020125	ER25	1:1	6000	50Nm	X		X	82.36	-	-	48	-	-	CHSTER25 CHUB36 o 0100000
DW 00020225	ER25	1:1	6000	50Nm	X	P=70bar	X	81.76	-	-	71.5	-	-	CHSTER25 CHUB36 o 0100000
DW 00020132	ER32	1:1	6000	50Nm	X		X	98.16	-	-	48	-	-	CHSTER32 CHUB36 o 0100000
DW 00020232	ER32	1:1	6000	50Nm	X	P=70bar	X	97.56	-	-	71.5	-	-	CHSTER32 CHUB36 o 0100000
DW 00020022	WELDON 20	1:1	6000	50Nm	X		X	-	-	100	48	-	-	
DW 00021617	Ø16x17	1:1	6000	50Nm	X		X	-	61	-	48	16	17	CH_VTCROCE_M08 • CHUB36 o 0100000
DW 00022219	Ø22x19	1:1	6000	50Nm	X		X	-	62	-	48	22	19	CH_VTCROCE_M10 • CHUB36 o 0100000
DW 00022240	Ø22x40	1:1	6000	50Nm	X		X	-	62	-	48	22	40	CH_VTCROCE_M10 • CHUB36 o 0100000
DW 00022721	Ø27x21	1:1	6000	50Nm	X		X	-	64	-	48	27	21	CH_VTCROCE_M12 • CHUB36 o 0100000
DW 00022733	Ø27x33	1:1	6000	50Nm	X		X	-	61	-	48	27	33	CH_VTCROCE_M12 • CHUB36 o 0100000
DW 00022750	Ø27x50	1:1	6000	50Nm	X		X	-	62.5	-	48	27	50	CH_VTCROCE_M12 • CHUB36 o 0100000

HYUNDAI-KIA (WIA)

MOD: SKT160TTMS/TTSY (LM1600TTMS/TTSY) - SKT180TTMS/TTSY (LM1800TTMS/TTSY) (L230LMSA)

MODULO MOTORIZZATO ASSIALE

Axial driven tool

Axial angetriebenes Werkzeug

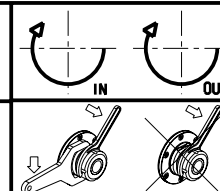

M.T. srl

Via Casino Albini 480
Tel. 0541/956034-957884

Fax 0541/956341

47842 S. GIOVANNI IN M. (RN)

e-mail: mtma@mtmarchetti.com

http://www.mtmarchetti.com

PRODUZIONE MODULI ROTANTI



PAGINA KIA150-2-30

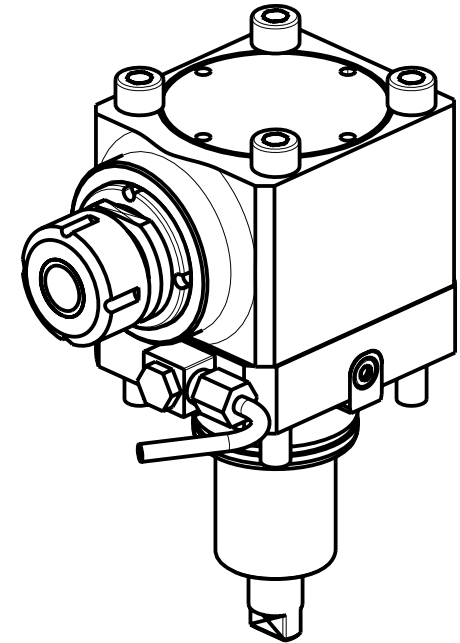
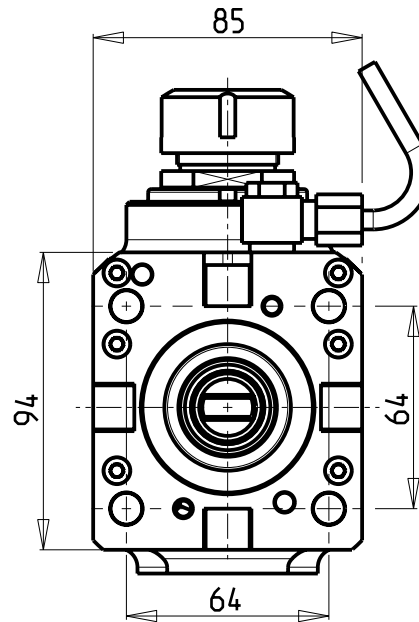
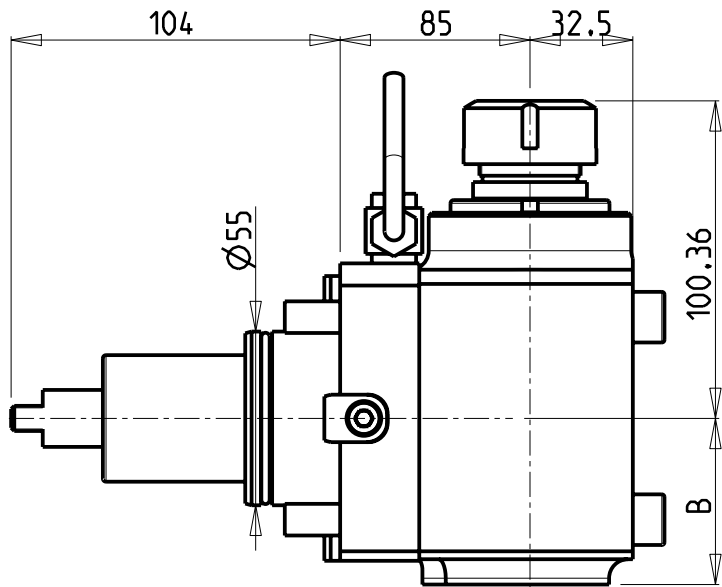

Cod. MT	Mandrino Spindel Spindel	i	RPM	Coppia Max Max Torque Max Drehmoment	Reversibile lato mandrino/contromandrino Reversible sub/main spindle side Umkehrbare Spindel-seite/ Gegenspindel-seite	Lubrificazione int. Coolant through Innenkuehlung	Lubrificazione est. Ext. coolant Aussenkuehlung	B	CHIAVI NON INCLUSE Keys not included Schlüssel nicht einbegriffen	
									CHSTER25	CHUB36
0892425	ER25	1:2	12000	30Nm	X		X	52.5	CHSTER25	CHUB36
0892525	ER25	1:2	12000	30Nm	X	P=70bar	X	79	CHSTER25	CHUB36

HYUNDAI-KIA (WIA)

MOD: SKT160TTMS/TTSY (LM1600TTMS/TTSY) - SKT180TTMS/TTSY (LM1800TTMS/TTSY) (L230LMSA)

MODULO MOTORIZZATO ASSIALE MOLTIPLICATO I = 1:2

Axial geared-up I=1:2 driven tool

Axial angetriebenes Werkzeug uebersetzt I=1:2

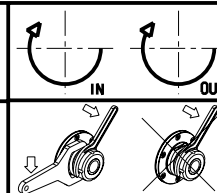

M.T. srl

Via Casino Albini 480
Tel. 0541/956034-957884

Fax 0541/956341

47842 S. GIOVANNI IN M. (RN)

e-mail: mtma@mtmarchetti.com

http://www.mtmarchetti.com

PRODUZIONE MODULI ROTANTI



PAGINA KIA200-2-10

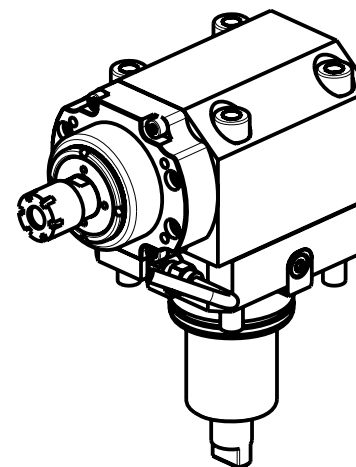
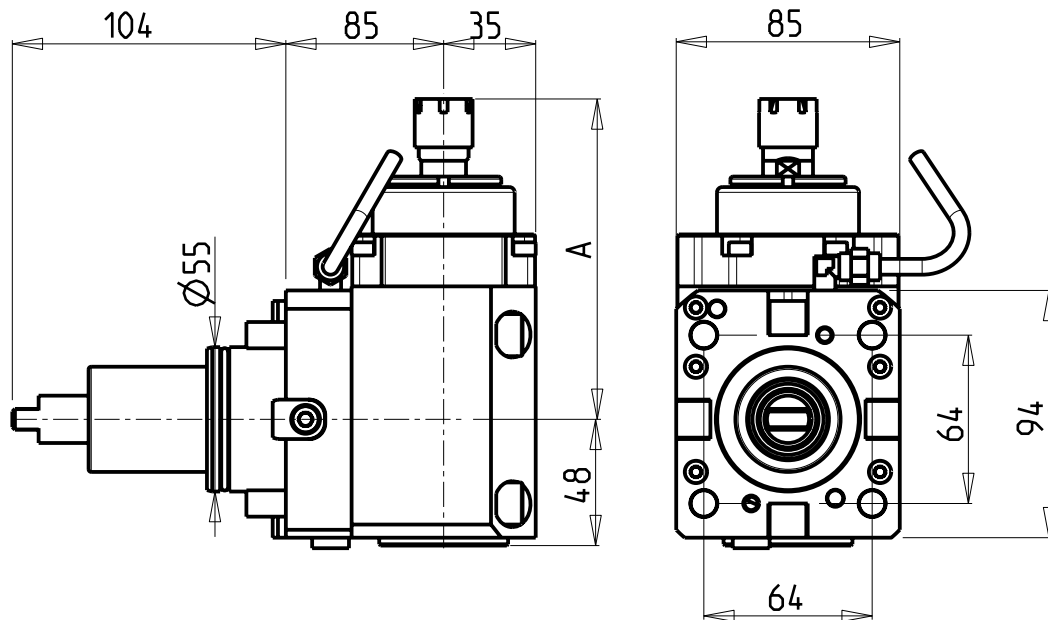

ATTENZIONE - ATTENTION - ACHTUNG

- PRIMA DI UTILIZZARE IL MOTORIZZATO CONSULTARE LE ISTRUZIONI ALLEGATE!
- BEFORE USING THE DRIVEN TOOL, PLEASE CHECK THE ENCLOSED INSTRUCTION SHEET!
- VOR DER BENUTZUNG DES ANGETRIEBENEN WERKZEUGES, DIE BEILIEGENDEN INSTRUKTIONEN DURCHLESEN!

ATTENZIONE - ATTENTION - ACHTUNG

- Per lo smontaggio degli utensili utilizzare sempre la chiave di contrasto come indicato nel manuale d'uso.
- For disassembly of the tools use always the contrast key as mentioned in the user instructions.
- Fuer das Abmontieren der Werkzeuge immer den Gegenschlüssel benutzen wie in der Bedienungsanleitung erwaeht.

Cod. MT	Mandrino Spindle Spindel	I	RPM MAX	Coppia Max Max Torque Max Drehmoment	Reversibile lato mandrino/contromandrino Reversible sub/main spindle side Umkehrbare Spindel-seite/ Gegenspindel-seite	Lubrificazione int. Coolant through Innenkuehlung	Lubrificazione est. Ext. coolant Aussenkuehlung	A	CHIAVI INCLUSE Keys included Schluessel einbegriffen	
DW 00190216	ER16	1:5.625	22500	6Nm	X		X	121.8	CHMNER16	CHUB17
DW 00190211	ER11	1:5.625	22500	6Nm	X	P=30bar		134	CHMNER11	CHUB11

HYUNDAI-KIA (WIA)

MOD: SKT160TTMS/TTSY (LM1600TTMS/TTSY) - SKT180TTMS/TTSY (LM1800TTMS/TTSY) (L230LMSA)

MODULO MOTORIZZATO ASSIALE MOLTIPLICATO I = 1:5.625

Axial geared-up I=1:5.625 driven tool

Axial angetriebenes Werkzeug uebersetzt I=1:5.625

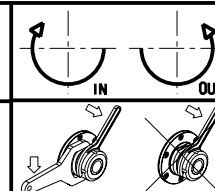

M.T. srl

Via Casino Albini 480
Tel. 0541/956034-957884
Fax 0541/956341

47842 S. GIOVANNI, IN M. (RN)
e-mail: mtma@mtmarchetti.com
http://www.mtmarchetti.com

PRODUZIONE MODULI ROTANTI



PAGINA KIA210-2-10

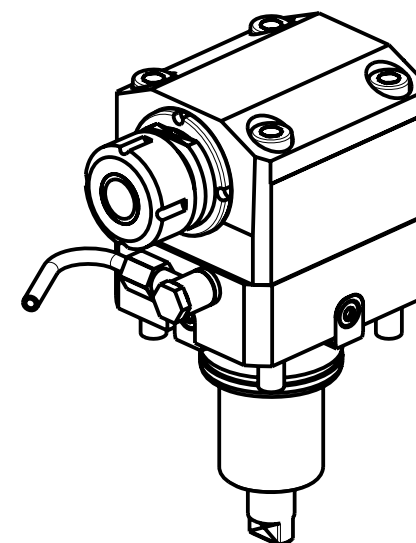
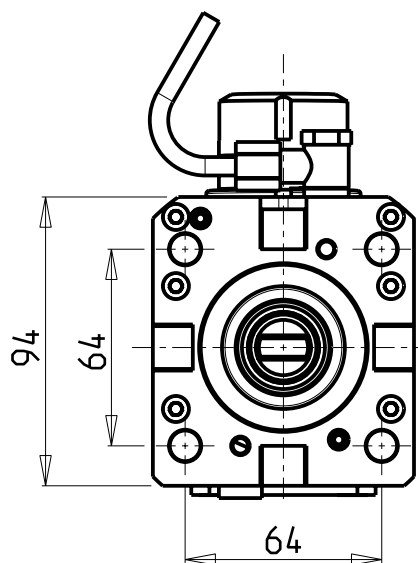
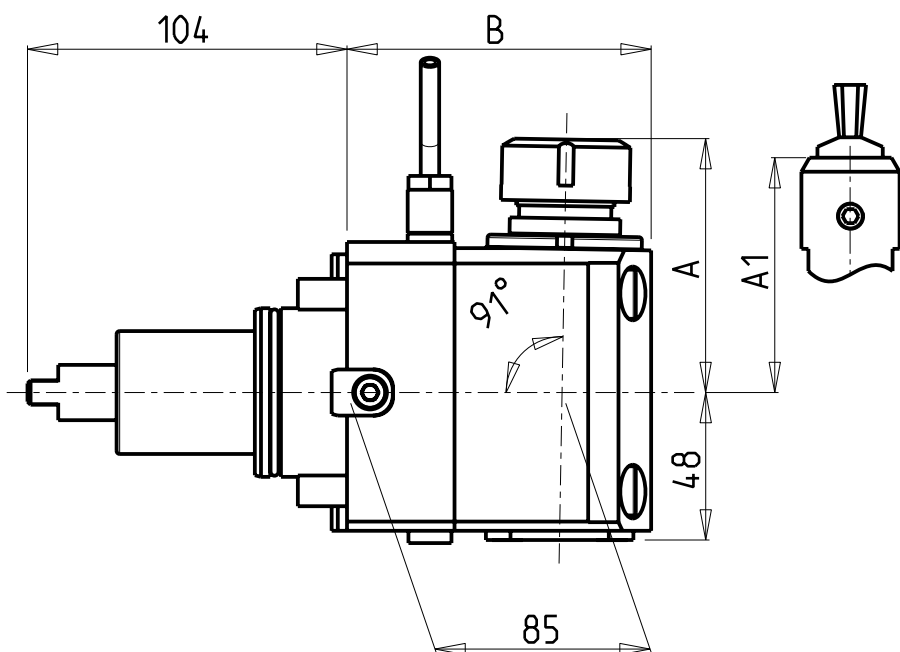

Cod. MT	Mandrino Spindle Spindel	I	RPM	Coppia Max Max Torque Max Drehmoment	Reversibile lato mandrino/contromandrino Reversible sub/main spindle side Umkehrbare Spindel-seite/ Gegenspindel-seite	Lubrificazione est. Ext. coolant Aussenkuehlung	A	A1	B	CHIAVI NON INCLUSE Keys not included Schluessel nicht einbegriffen	
DW 00029125	ER25	1:1	6000	50Nm	X	X	82.35	-	114	CHSTER25	CHUB36 o 0100000
DW 00029108	WELDON 8	1:1	6000	50Nm	X	X	-	76.5	114		
DW 00029110	WELDON 10	1:1	6000	50Nm	X	X	-	76.5	114		
DW 00029112	WELDON 12	1:1	6000	50Nm	X	X	-	76.5	114		
DW 00029116	WELDON 16	1:1	6000	50Nm	X	X	-	73.5	114		

HYUNDAI-KIA (WIA)

MOD: SKT160TTMS/TTSY (LM1600TTMS/TTSY) - SKT180TTMS/TTSY (LM1800TTMS/TTSY) (L230LMSA)

MODULO MOTORIZZATO ASSIALE PER POLIGONATURA INTERNA

Axial driven tool for internal polygon-making

Axial angetriebenes Werkzeug fuer interne Facettierung

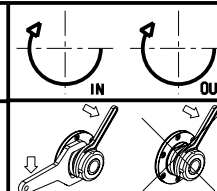

M.T. srl

Via Casino Albini 480
Tel. 0541/956034-957884
Fax 0541/956341

47842 S. GIOVANNI IN M. (RN)
e-mail: mtma@mtmarchetti.com
http://www.mtmarchetti.com

PRODUZIONE MODULI ROTANTI



PAGINA KIA230-2-10

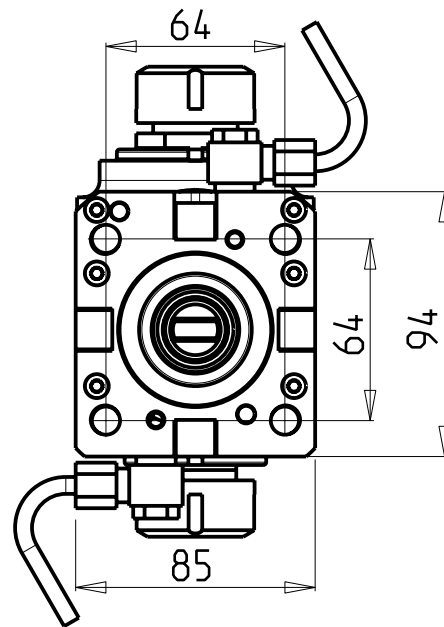
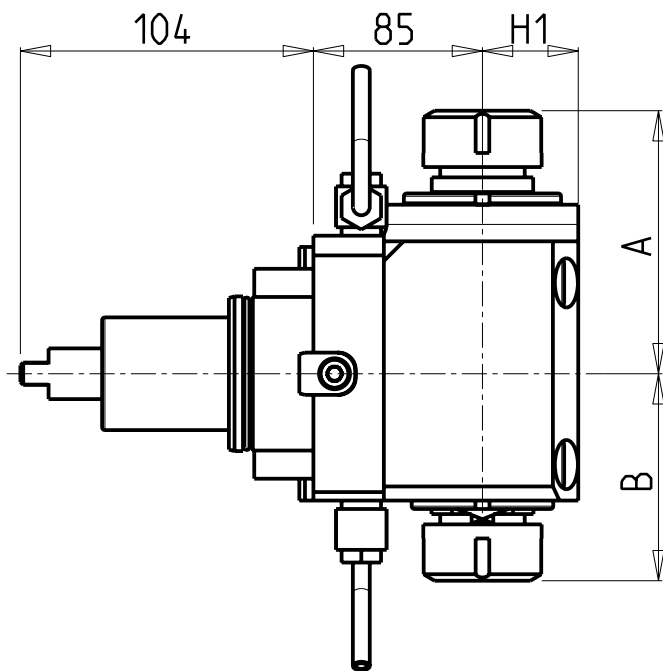

ATTENZIONE - ATTENTION - ACHTUNG

- Per lo smontaggio degli utensili utilizzare sempre la chiave di contrasto come indicato nel manuale d'uso.
- For disassembly of the tools use always the contrast key as mentioned in the user instructions.
- Fuer das Abmontieren der Werkzeuge immer den Gegenschlüssel benutzen wie in der Bedienungsanleitung erwahnt.

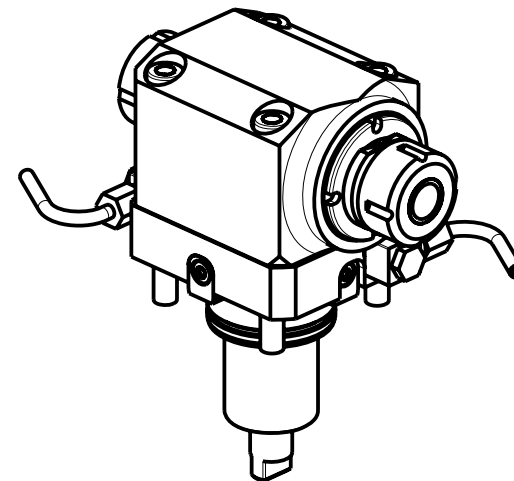

Cod. MT	Mandrino Spindle Spindel	I	RPM	Coppia Max Max Torque Max Drehmoment	Reversibile lato mandrino/contromandrino Reversible sub/main spindle side Umkehrbare Spindelsete/Gegenspindelsete	Lubrificazione est. Ext. coolant Aussenkuehlung	A	B	H1	CHIAVI NON INCLUDE Keys not included Schluessel nicht einbegriffen	
DW 00080232	ER32+ER32	1:1	6000	50Nm	X	X	100.56	78.96	34	CHSTER32	CHUB36 o 0100000
DW 00080225	ER25+ER25	1:1	6000	50Nm	X	X	93.36	73.46	34	CHSTER25	CHUB36+CHUB29
DW 00022516	ER25+ER16	1:1	6000	50Nm	X	X	81.86	66	29	CHMNER16+CHSTER25	CHUB36 o 0100000
DW 00021616	ER16+ER16	1:1	6000	50Nm	X	X	81.2	66	29	CHMNER16	CHUB36 o 0100000

HYUNDAI-KIA (WIA)

MOD: SKT160TTMS/TTSY (LM1600TTMS/TTSY) - SKT180TTMS/TTSY (LM1800TTMS/TTSY) (L230LMSA)

MODULO MOTORIZZATO ASSIALE BISPORGENTE

Axial opposite face twin driven tool

Axial angetriebenes Werkzeug halb vorspringend

M.T. srl

Via Casino Albini 480
Tel. 0541/956034-957884

Fax 0541/956341

47842 S. GIOVANNI IN M. (RN)

e-mail: mtma@mtmarchetti.com

http://www.mtmarchetti.com

PRODUZIONE MODULI ROTANTI



PAGINA KIA240-2-10

ATTENZIONE - ATTENTION - ACHTUNG

- Per lo smontaggio degli utensili utilizzare sempre la chiave di contrasto come indicato nel manuale d'uso.
- For disassembly of the tools use always the contrast key as mentioned in the user instructions.
- Fuer das Abmontieren der Werkzeuge immer den Gegenschlüssel benutzen wie in der Bedienungsanleitung erwäehnt.

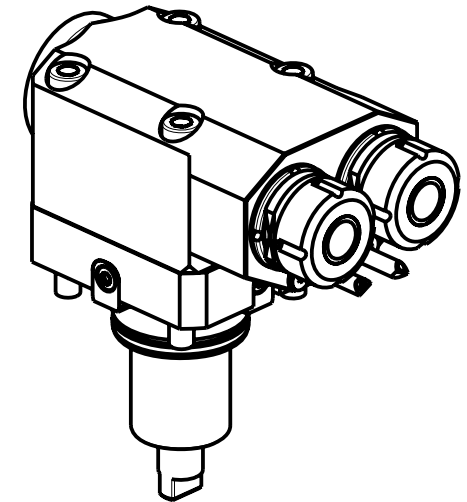
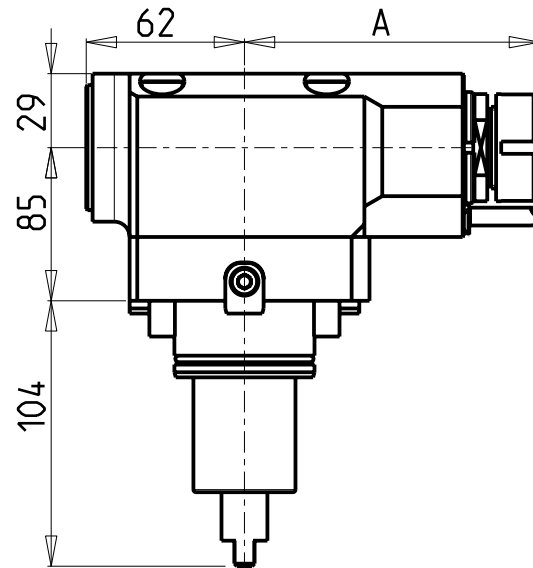
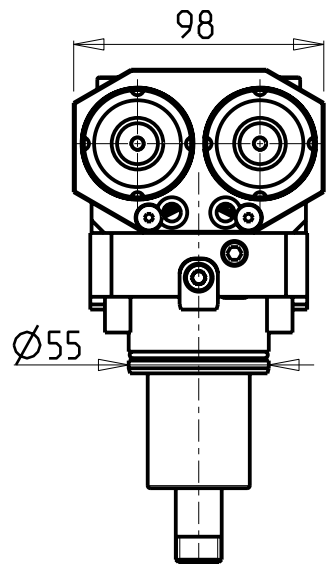
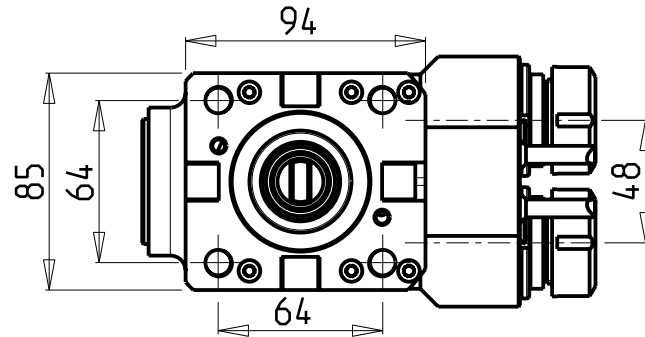

Cod. MT	Mandrino Spindle Spindel	I	RPM	Coppia Max Max Torque Max Drehmoment	Reversibile lato mandrino/contromandrino Reversible sub/main spindle side Umkehrbare Spindel-seite/ Gegenspindel-seite	Lubrificazione est. Ext. coolant Aussenkuehlung	A	CHIAVI NON INCLUSE Keys not included Schlüssel nicht einbegriffen	
					X	X		CHMNER16	CHUB17
DW 00101216	ER16	1:1	6000	30Nm	X	X	115.15	CHMNER16	CHUB17
DW 00101225	ER25	1:1	6000	30Nm	X	X	115.61	CHSTER25	MNL0210007

HYUNDAI-KIA (WIA)

MOD: SKT160TTMS/TTSY (LM1600TTMS/TTSY) - SKT180TTMS/TTSY (LM1800TTMS/TTSY) (L230LMSA)

MODULO MOTORIZZATO ASSIALE 2 USCITE IN Y

Axial single side twin head driven tool in Y

Axial angetriebenes Werkzeug 2 Ausgaenge in Y

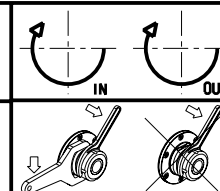

M.T. srl

Via Casino Albini 480
Tel. 0541/956034-957884

Fax 0541/956341

47842 S. GIOVANNI IN M. (RN)

e-mail: mtma@mtmarchetti.com

http://www.mtmarchetti.com

PRODUZIONE MODULI ROTANTI



PAGINA KIA260-2-10

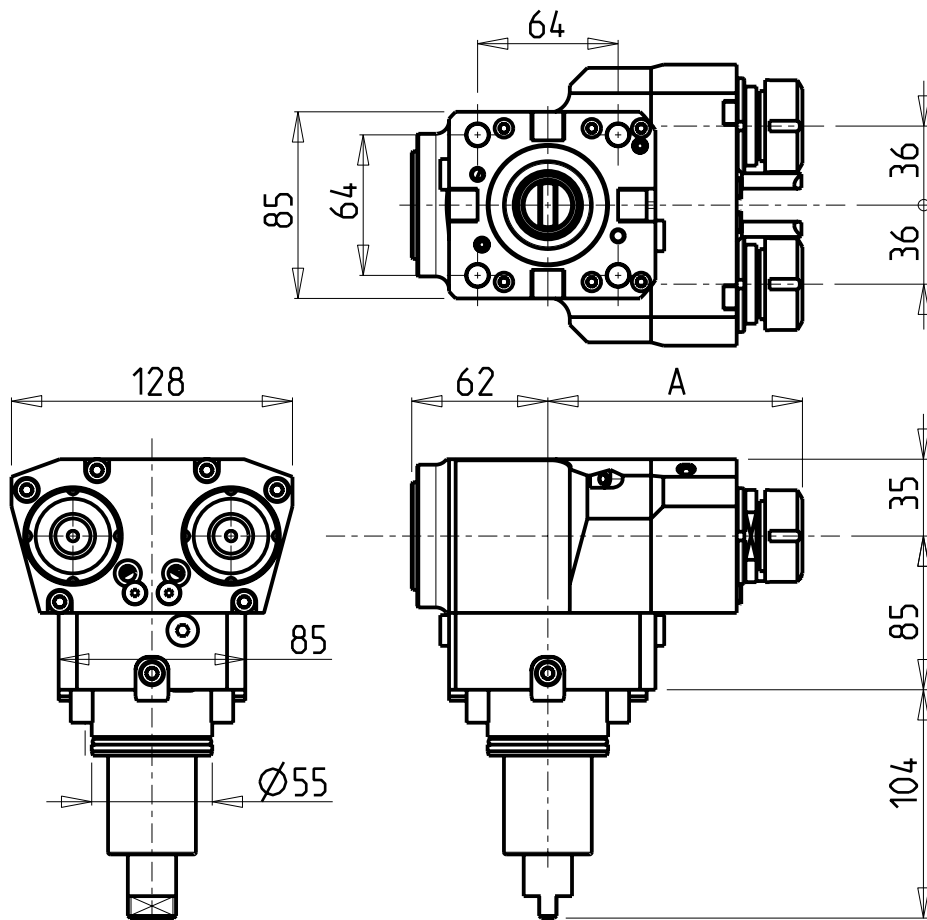

ATTENZIONE - ATTENTION - ACHTUNG

- Per lo smontaggio degli utensili utilizzare sempre la chiave di contrasto come indicato nel manuale d'uso.
- For disassembly of the tools use always the contrast key as mentioned in the user instructions.
- Fuer das Abmontieren der Werkzeuge immer den Gegenschlüssel benutzen wie in der Bedienungsanleitung erwäehnt.

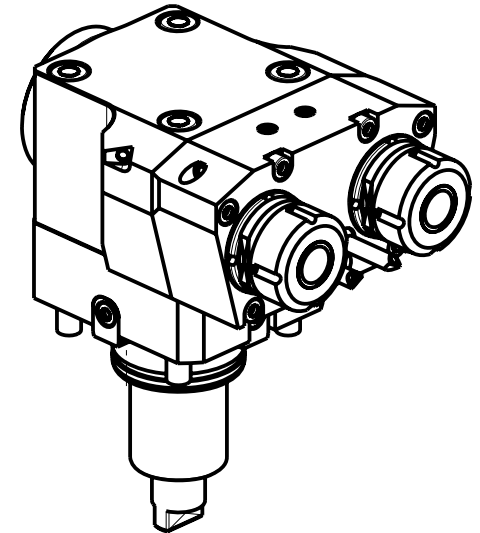

Cod. MT	Mandrino Spindle Spindel	I	RPM	Coppia Max Max Torque Max Drehmoment	Reversibile lato mandrino/contromandrino Reversible sub/main spindle side Umkehrbare Spindel-seite/ Gegenspindel-seite	Lubrificazione est. Ext. coolant Aussenkuehlung	A	CHIAVI NON INCLUSE Keys not included Schlüssel nicht einbegriffen	
								CHMNER16	CHUB17
DW 00952216	ER16	1:2	12000	20Nm	X	X	115	CHMNER16	CHUB17
DW 00952225	ER25	1:2	12000	20Nm	X	X	115.96	CHSTER25	CHUB36

NEW

NEW

HYUNDAI-KIA (WIA)

MOD: SKT160TTMS/TTSY (LM1600TTMS/TTSY) - SKT180TTMS/TTSY (LM1800TTMS/TTSY) (L230LMSA)

MODULO MOTORIZZATO ASSIALE 2 USCITE IN Y MOLTIPLICATO I=1:2

Axial geared-up I=1:2 single side twin head driven tool in Y

Axial angetriebenes Werkzeug 2 Ausgaenge in Y uebersetzt I=1:2

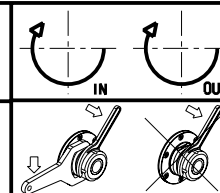

M.T. srl

Via Casino Albini 480
Tel. 0541/956034-957884
Fax 0541/956341

47842 S. GIOVANNI IN M. (RN)
e-mail: mtma@mtmarchetti.com
http://www.mtmarchetti.com

PRODUZIONE MODULI ROTANTI



PAGINA KIA261-2-10

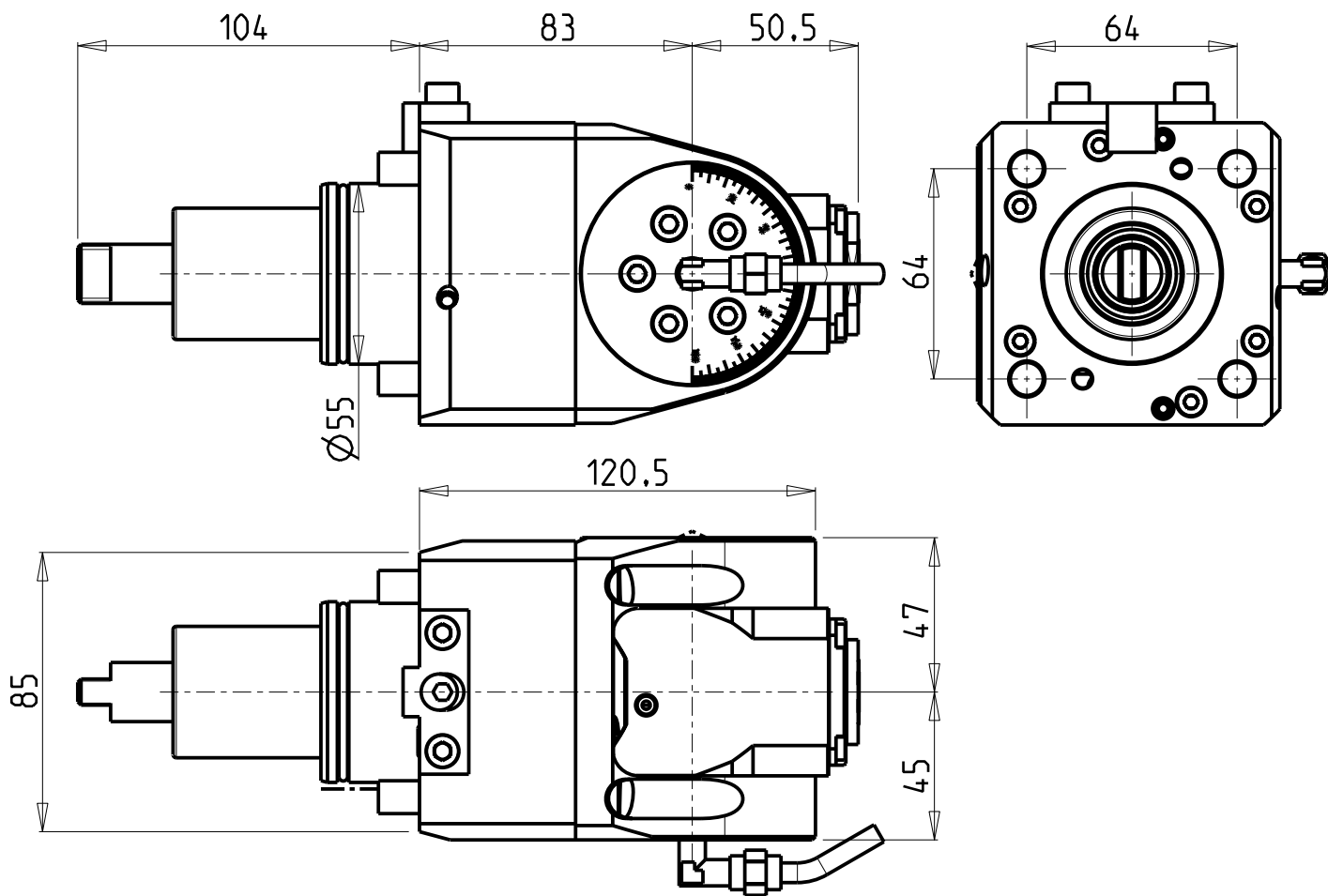

ATTENZIONE - ATTENTION - ACHTUNG

- VERIFICARE LE MISURE DI INGOMBRO PER POSSIBILE INTERFERENZA SU ALCUNI MODELLI DI MACCHINE
- Please check the overall sizes for possible interferences on some machine models
- Bitte überprüfen sie das ausmass um mögliche interferenzen auf einigen maschinen modellen zu vermeiden

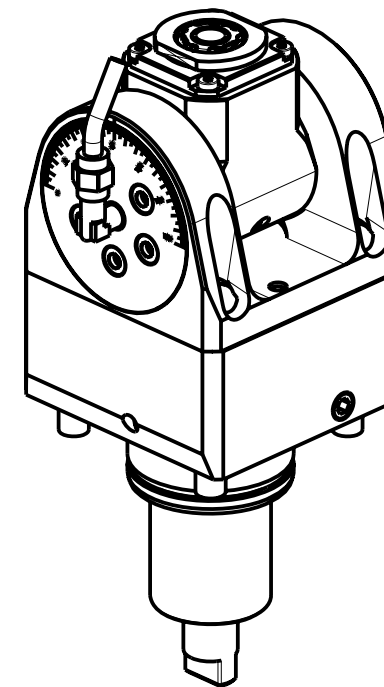

Cod. MT	Mandrino Spindle Spindel	I	RPM	Coppia Max Max Torque Max Drehmoment	Lubrificazione int. Coolant through Innenkuehlung	Lubrificazione est. Ext. coolant Aussenkuehlung	CHIAVI INCLUSE Keys included Schlüssel inbegriffen				
DW 00661120	ERA20	1:1	6000	30Nm		X	CHUB22	CHUB36	CHTAER20ZC	CHESL08	NEW
DW 00661220	ERA20	1:1	6000	30Nm	P=70bar	X	CHUB22	CHUB36	CHTAER20ZC	CHESL08	

HYUNDAI-KIA (WIA)

MOD: SKT160TTMS/TTSY (LM1600TTMS/TTSY) - SKT180TTMS/TTSY (LM1800TTMS/TTSY) (L230LMSA)

MODULO MOTORIZZATO ORIENTABILE ±90°
±90° adjustable angle driven tool

Angetriebenes Werkzeug schwenkbar

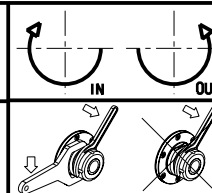

M.T. srl

Via Casino Albini 480
Tel. 0541/956034-957884
Fax 0541/956341

47842 S. GIOVANNI IN M. (RN)
e-mail: mtma@mtmarchetti.com
http://www.mtmarchetti.com

PRODUZIONE MODULI ROTANTI



PAGINA KIA335-2-10

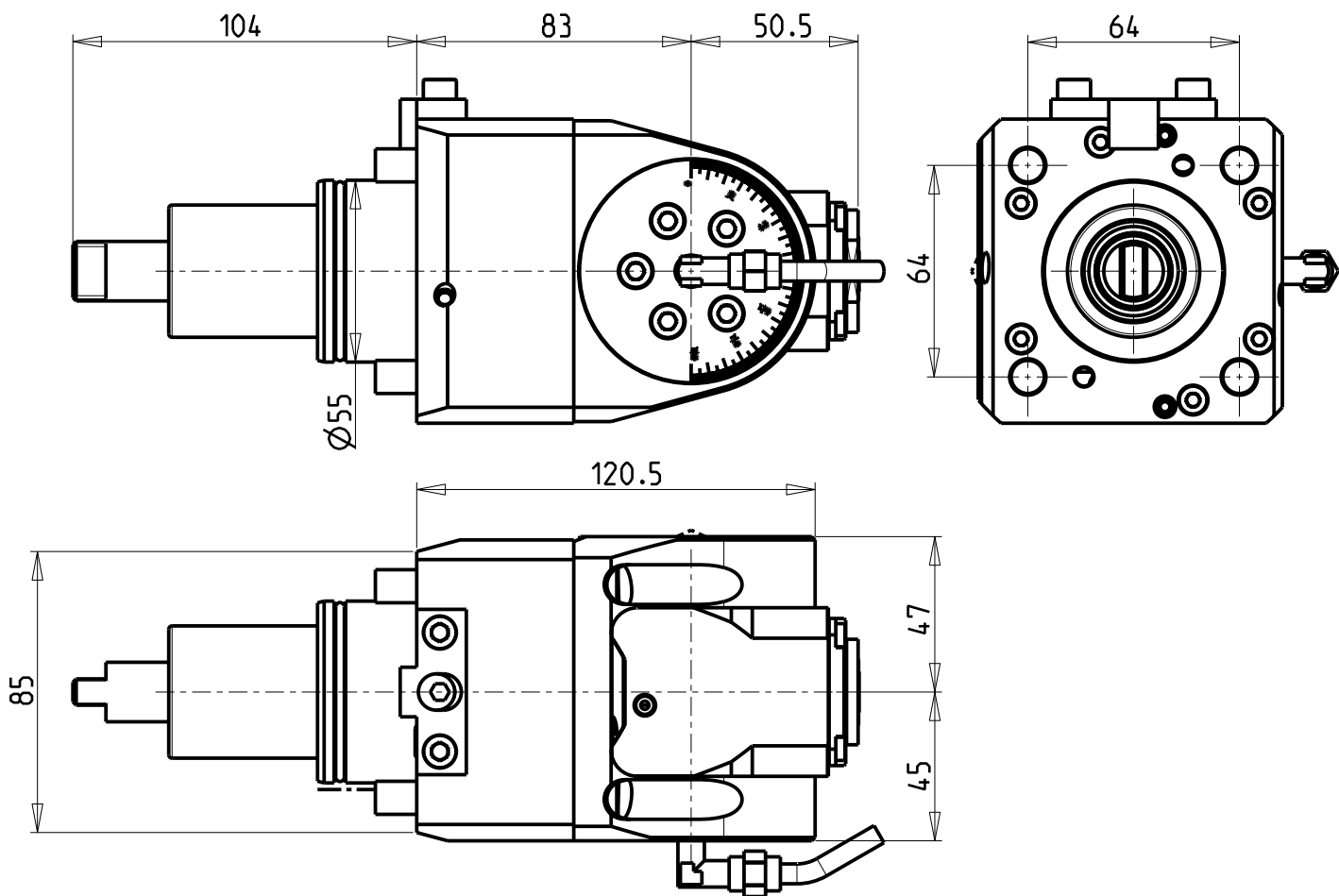

ATTENZIONE - ATTENTION - ACHTUNG

- Per lo smontaggio degli utensili utilizzare sempre la chiave di contrasto come indicato nel manuale d'uso.
- For disassembly of the tools use always the contrast key as mentioned in the user instructions.
- Fuer das Abmontieren der Werkzeuge immer den Gegenschlüssel benutzen wie in der Bedienungsanleitung erwahnt.

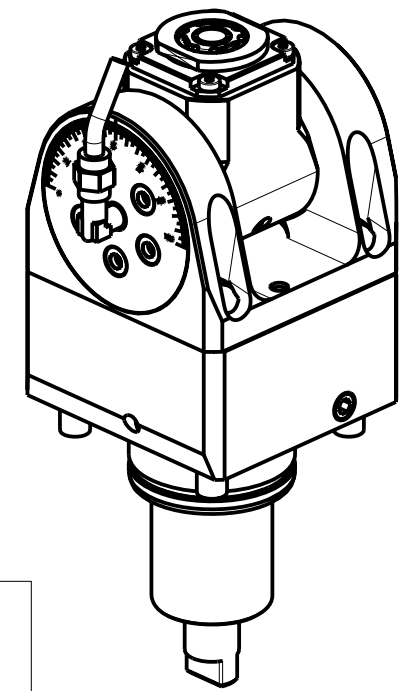

Cod. MT	Mandrino Spindle Spindel	I	RPM	Coppia Max Max Torque Max Drehmoment	Lubrificazione int. Coolant through Innenkuehlung	Lubrificazione est. Ext. coolant Aussenkuehlung	CHIAVI INCLUSE Keys included Schluesssel inbegriffen			
DW 00661316	ERA16	1:2	12000	8Nm		X	CHUB19_SP3	CHUB32	CHTAER16ZC	CHESL07
DW 00661416	ERA16	1:2	12000	8Nm	P=70bar	X	CHUB19_SP3	CHUB32	CHTAER16ZC	CHESL07

HYUNDAI-KIA (WIA)

MOD: SKT160TTMS/TTSY (LM1600TTMS/TTSY) - SKT180TTMS/TTSY (LM1800TTMS/TTSY) (L230LMSA)

MODULO MOTORIZZATO ORIENTABILE +/-90° MOLTIPLICATO I=1:2

+/-90° adjustable angle driven tool geared-up I=1:2

Angetriebenes Werkzeug schwenkbar +/-90° uebersetzt I=1:2

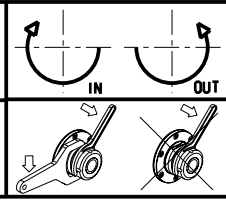

M.T. srl
Via Casino Albini 480
Tel. 0541/956034-957884
Fax 0541/956341
47842 S. GIOVANNI IN M. (RN)
e-mail: mtma@mtmarchetti.com
http://www.mtmarchetti.com

PRODUZIONE MODULI ROTANTI



PAGINA KIA336-2-10

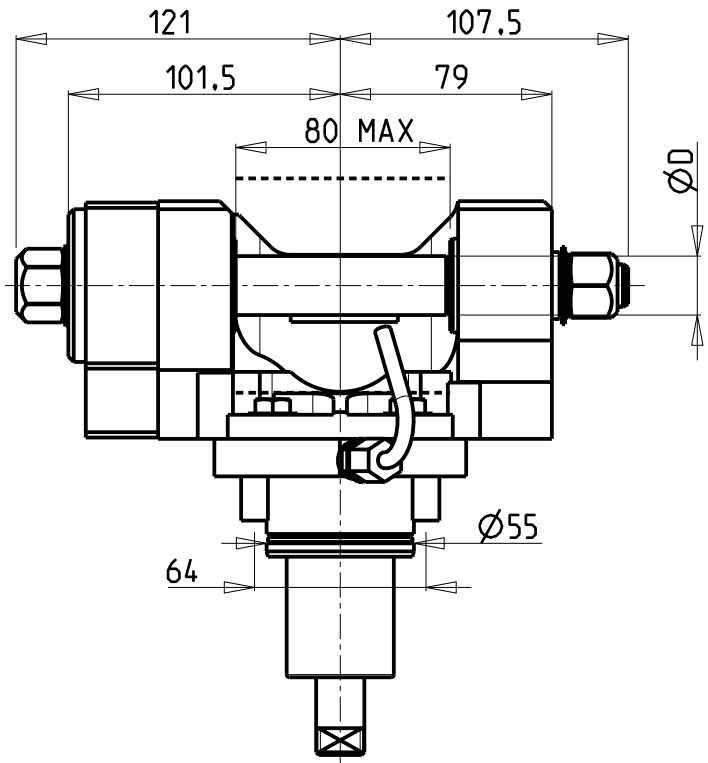
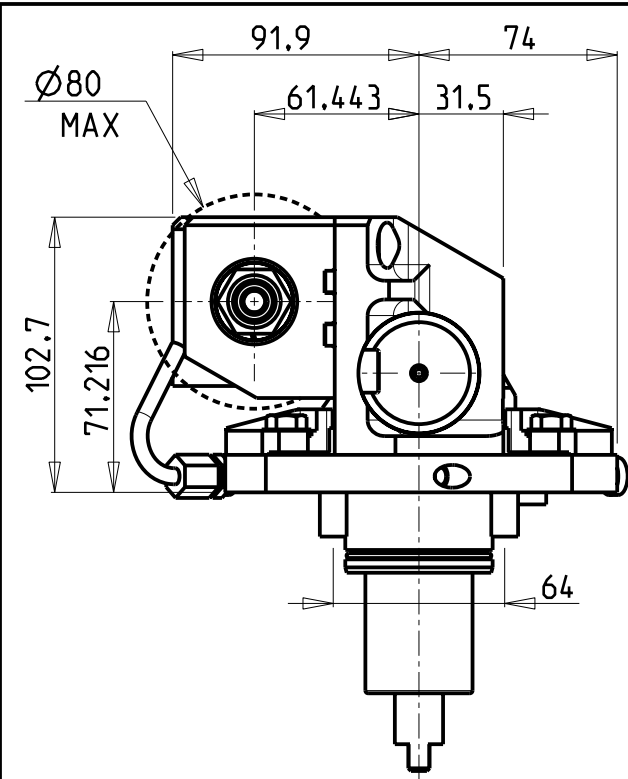

INCLINAZIONE
REGOLABILE $\pm 20^\circ$

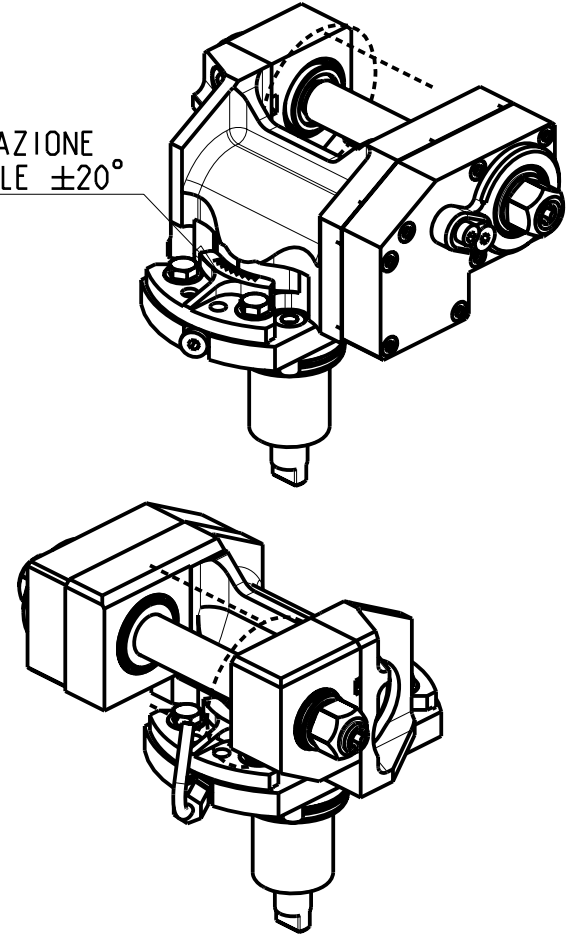

DOTAZIONI - SUPPLIED WITH - AUSSTATTUNG

mm / inch	- N°1 ALBERO + DISTANZIALI - N°1 SHAFT + SPACER - N°1 DORN + ABSTANDSSTUECK
-----------	---

PER ALBERI E DISTANZIALI VEDI PAG. TBL250-1-00
FOR SHAFT END SPACER SEE PAGE TBL250-1-00
FUER DORN UND ABSTANDSSTUECK SEITE TBL250-1-00

Cod. MT	I	RPM max	Coppia Max Max Torque Max Drehmoment	Reversibile lato mandrino/contromandrino Reversible sub/main spindle side Umkehrbare Spindel-seite/ Gegenspindel-seite	Lubrificazione est. Ext. coolant Aussenkuehlung	D (mm)	D (Inch)	CHIAVI INCLUSE Keys included Schlüssel inbegriffen		
								CHUB24	CHUB13	CHESL08
0621100	1:1	6000	60Nm	X	X	16-22-27-32	3/4"-1"-1 1/4"	CHUB24	CHUB13	CHESL08
0622100	2:1	3000	80Nm	X	X	16-22-27-32	3/4"-1"-1 1/4"	CHUB24	CHUB13	CHESL08

HYUNDAI-KIA (WIA)
MOD: SKT160TTMS/TTSY (LM1600TTMS/TTSY) - SKT180TTMS/TTSY (LM1800TTMS/TTSY) (L230LMSA)
MODULO MOTORIZZATO PORTACREATORE
Driven gear hobber
Angetriebenes Zahnradwaelzfraes-Werkzeug

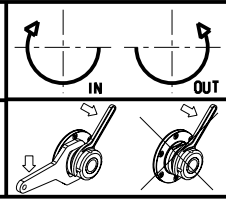

M.T. srl
Via Casino Albini 480
Tel. 0541/956034-957884
Fax 0541/956341
47842 S. GIOVANNI IN M. (RN)
e-mail: mtma@mtmarchetti.com
http://www.mtmarchetti.com

PRODUZIONE MODULI ROTANTI

PAGINA KIA340-2-00

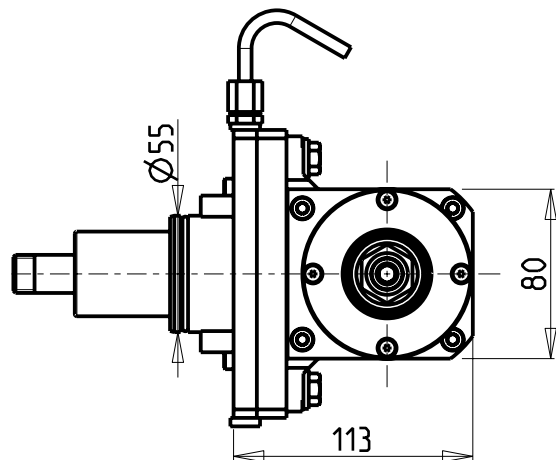
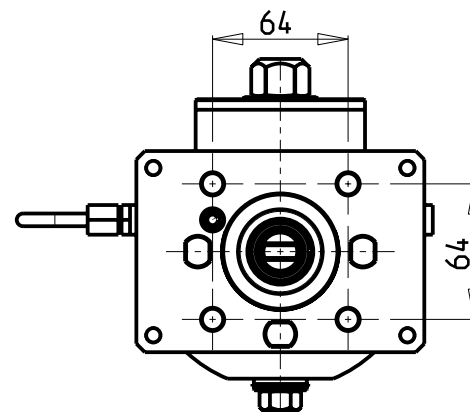
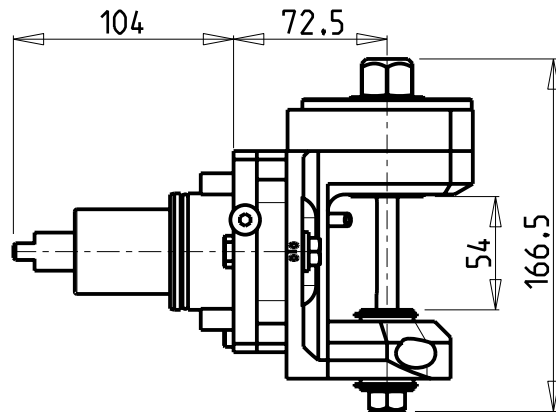
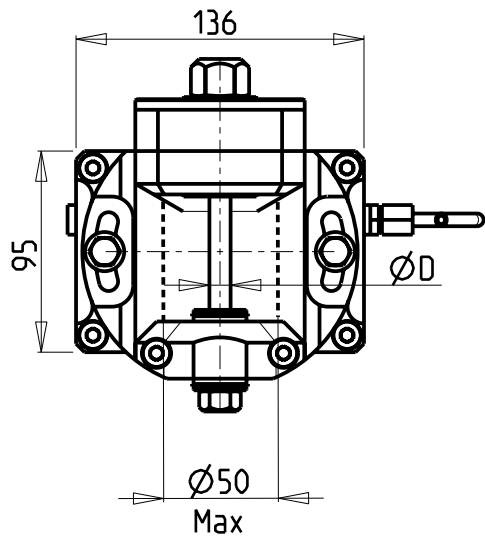

INCLINAZIONE
REGOLABILE $\pm 15^\circ$

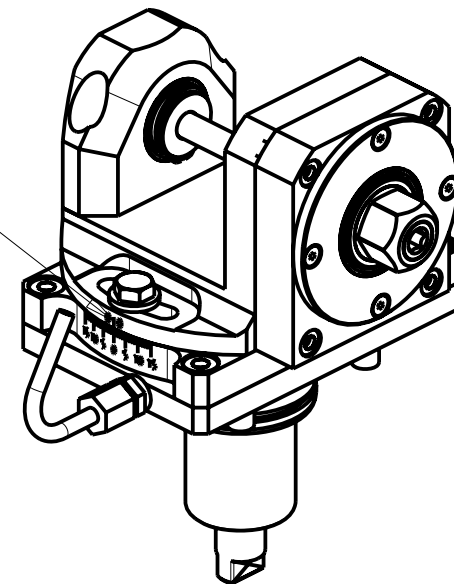

Cod. MT	i	RPM max	Coppia Max Max Torque Max Drehmoment	Lubrificazione est. Ext. coolant Aussenkuehlung	D (mm)	CHIAVI INCLUSE Keys included Schlüssel inbegriffen					
						CHUB24	CHUB13	CHESL08	CHESL06	CHESL04	
DW 00051108	1:1	6000	50Nm	X	8	CHUB24	CHUB13	CHESL08	CHESL06	CHESL04	
DW 00051110	1:1	6000	50Nm	X	10	CHUB24	CHUB17	CHUB13	CHESL08	CHESL06	CHESL05
DW 00051113	1:1	6000	50Nm	X	13	CHUB24	CHUB19	CHUB13	CHESL08	CHESL06	
DW 00051116	1:1	6000	50Nm	X	16	CHUB24	CHUB13	CHESL08	CHESL06		

HYUNDAI-KIA (WIA)

MOD: SKT160TTMS/TTSY (LM1600TTMS/TTSY) - SKT180TTMS/TTSY (LM1800TTMS/TTSY) (L230LMSA)

MODULO MOTORIZZATO PORTACREATORE RADIALE

Radial driven gear hobber tool

Angetriebenes Zahnradwaelzfraes-Werkzeug Radial-Version

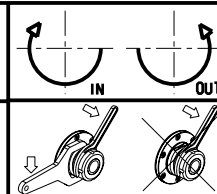

M.T. srl

Via Casino Albini 480
Tel. 0541/956034-957884

Fax 0541/956341

47842 S. GIOVANNI IN M. (RN)

e-mail: mtma@mtmarchetti.com

http://www.mtmarchetti.com

PRODUZIONE MODULI ROTANTI



PAGINA KIA340-2-30

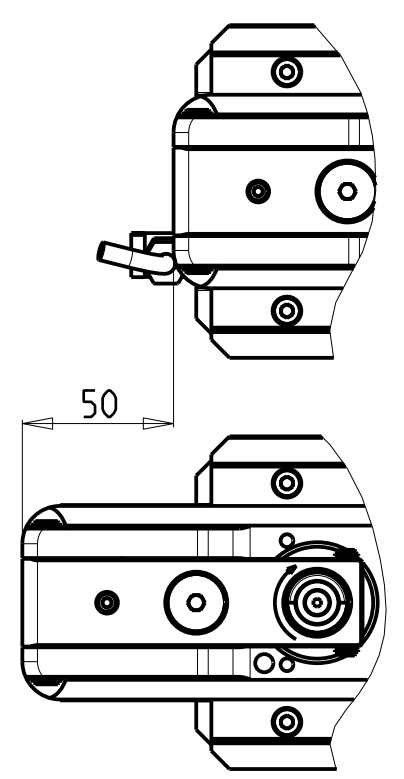
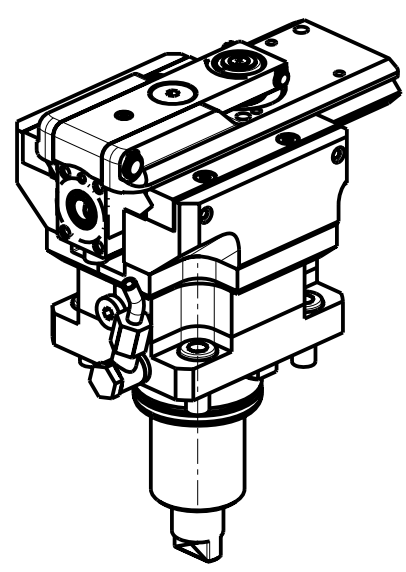
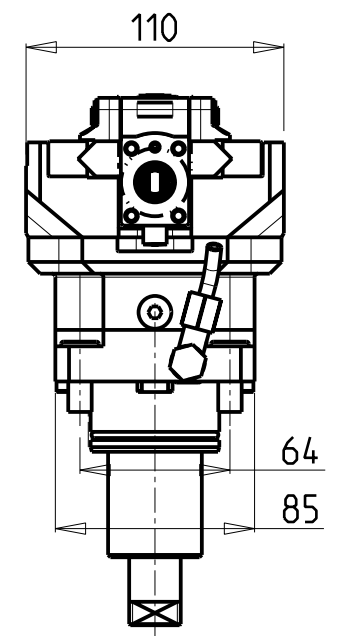
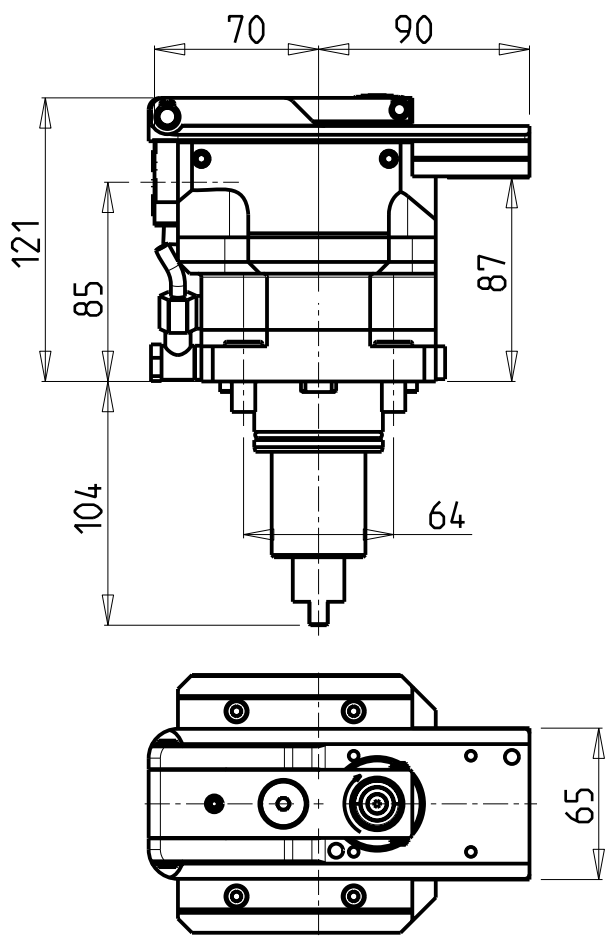

Cod. MT	I	RPM MAX	Reversibile lato mandrino/contromandrino Reversible sub/main spindle side Umkehrbare Spindel-seite/ Gegenspindel-seite	Lubr. esterna Ext. coolant Aussenkuehlung	
DW01030100	4:1	2000	X	X	NEW

PER UTENSILI STOZZATORI VEDI PAG. TBL400-1-00
 FOR DRIVEN SLOTTING TOOL CUTTING-TOOLS SEE PAGE TBL400-1-00
 FÜR NUTENSTOSS-WERKZEUG SCHNEIDWERKZEUGE SIEHE SEITE TBL400-1-00

HYUNDAI-KIA (WIA)
 MOD: SKT160TTMS/TTSY (LM1600TTMS/TTSY) - SKT180TTMS/TTSY (LM1800TTMS/TTSY) (L230LMSA)
 MODULO MOTORIZZATO STOZZATORE
 Slotting driven tool
 Keilnutenstossmaschine

M.T. srl
 Via Casino Albini 480
 Tel. 0541/956034-957884
 Fax 0541/956341
 47842 S. GIOVANNI IN M. (RN)
 e-mail: mtma@mtmarchetti.com
 http://www.mtmarchetti.com

PRODUZIONE MODULI ROTANTI



PAGINA KIA360-2-00

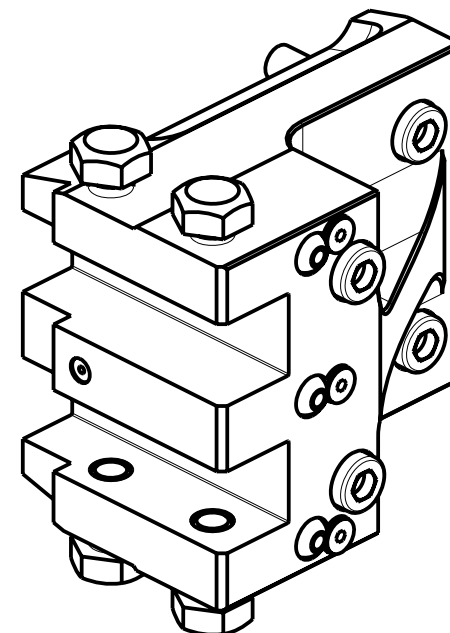
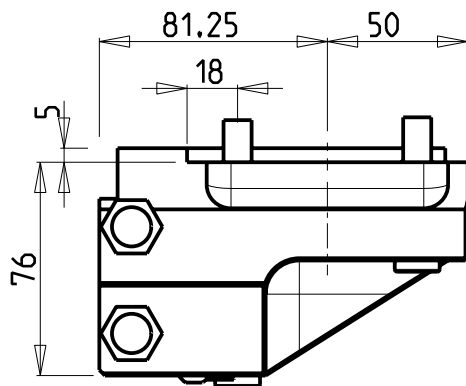
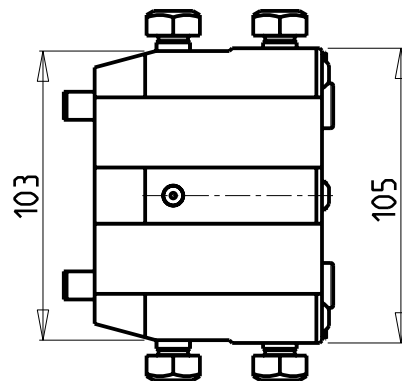
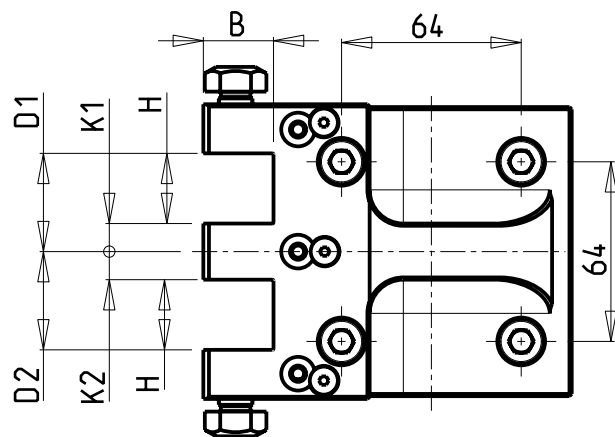

Cod. MT	N°Utensili N°Tools N°Werkzeuge	Reversibile lato mandrino/contromandrino Reversible sub/main spindle side Umkehrbare Spindel-seite/ Gegenspindel-seite	Misure Dimensions Masse	H	B	K1	K2	D1	D2
0772500	2	X	mm	25	25	10	10	35	35
0772540	2	X	inch	1"	1"	3/8"	3/8"	1 3/8"	1 3/8"

HYUNDAI-KIA (WIA)

MOD: SKT160TTMS/TTSY (LM1600TTMS/TTSY) - SKT180TTMS/TTSY (LM1800TTMS/TTSY) (L230LMSA)

PORTAUTENSILE RADIALE SOVRAPPOSTO

Radial single side twin static tool

Radial Werkzeughalter ueberlagert

M.T. srl

Via Casino Albini 480
Tel. 0541/956034-957884
Fax 0541/956341
47842 S. GIOVANNI IN M. (RN)
e-mail: mtma@mtmarchetti.com
http://www.mtmarchetti.com

PRODUZIONE MODULI ROTANTI



PAGINA KIA442-2-00

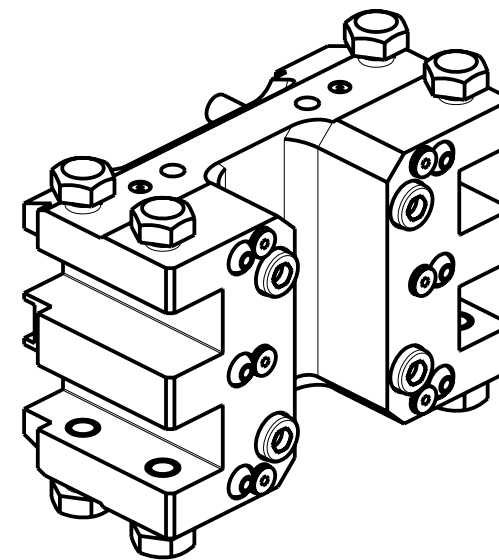
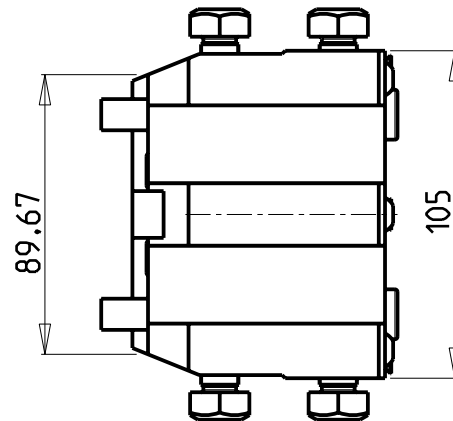
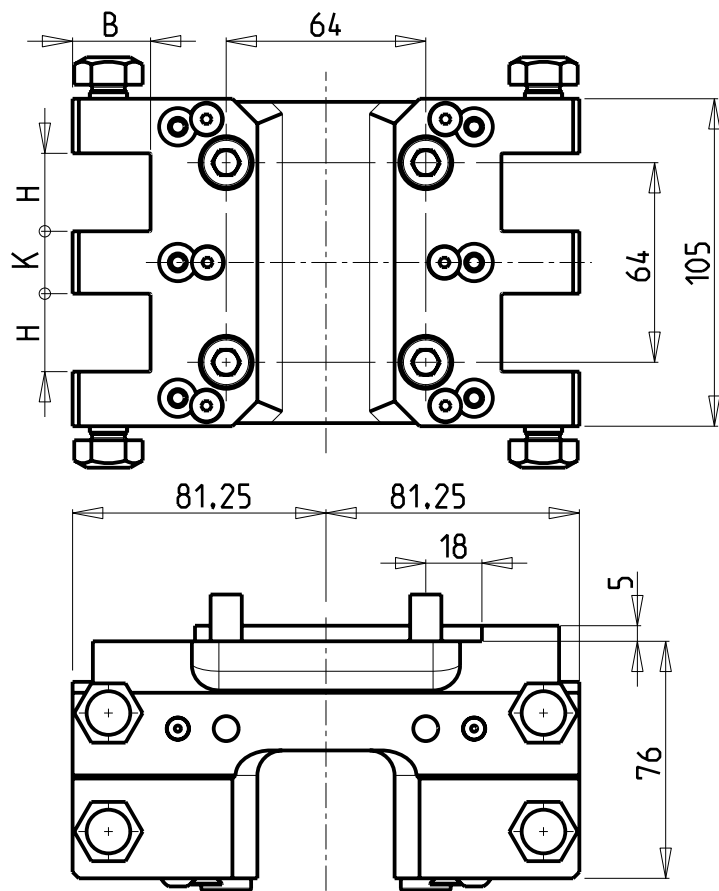

Cod. MT	N°Utensili N°Tools N°Werkzeuge	Reversibile lato mandrino/contromandrino Reversible sub/main spindle side Umkehrbare Spindel-seite/ Gegenspindel-seite	Misure Dimensions Masse	H	K	B
0762500	4	X	mm	25	20	25
0762540	4	X	inch	1"	3/4"	1"

HYUNDAI-KIA (WIA)

MOD: SKT160TTMS/TTSY (LM1600TTMS/TTSY) - SKT180TTMS/TTSY (LM1800TTMS/TTSY) (L230LMSA)

PORTAUTENSILE RADIALE DOPPIO SOVRAPPOSTO

Radial double side twin static tool

Radial Doppel-Werkzeughalter ueberlagert

M.T. srl

Via Casino Albini 480
Tel. 0541/956034-957884
Fax 0541/956341
47842 S. GIOVANNI IN M. (RN)
e-mail: mtma@mtmarchetti.com
http://www.mtmarchetti.com

PRODUZIONE MODULI ROTANTI



PAGINA KIA463-2-00

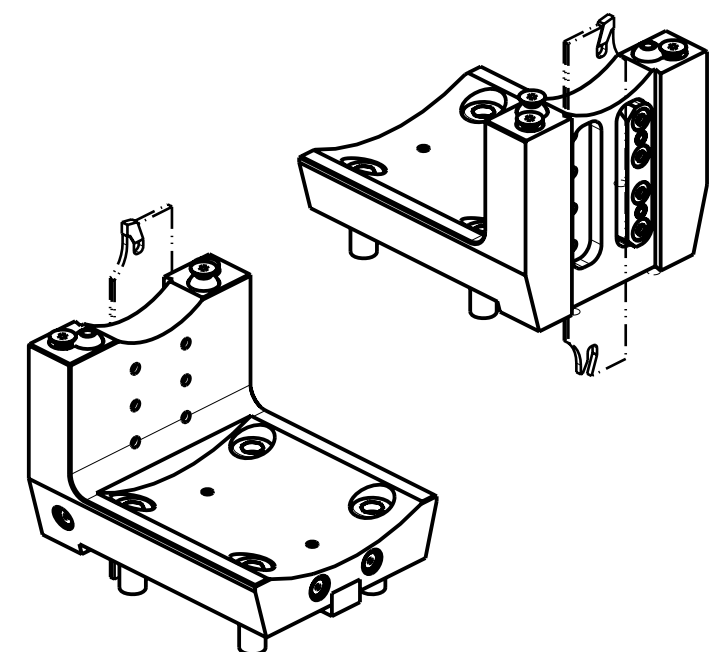
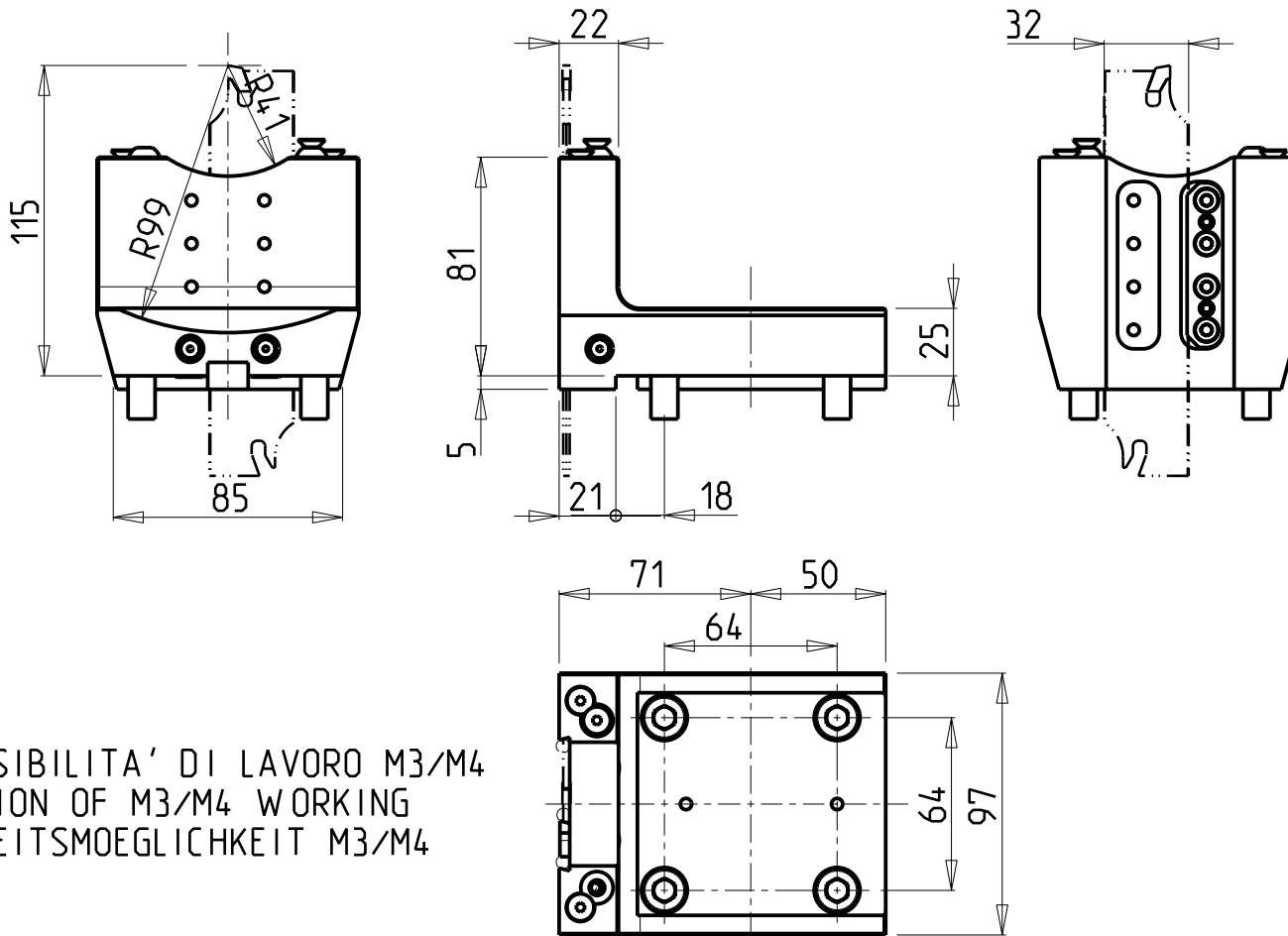

POSSIBILITA' DI LAVORO M3/M4
 OPTION OF M3/M4 WORKING
 ARBEITSMOEGlichkeit M3/M4

DOTAZIONI - SUPPLIED WITH - AUSSTATTUNG

- N°1 - LAMA - BLADE - KLINGE ISCAR H=32 Sp. 3/4mm (KENNAMETAL OPTIONAL)
- N°10 - INSERTI - INSERTS - EINLAGEN
- N°1 - CHIAVE A T PER MONTAGGIO INSERTI
 - T-WRENCH FOR INSERT SET UP
 - T-SCHLUESSEL FUER EINSATZSTUECK-MONTAGE

Cod. MT	N°Utensili N°Tools N°Werkzeuge	Reversibile lato mandrino/contromandrino Reversible sub/main spindle side Umkehrbare Spindel-seite/ Gegenspindel-seite	Lubr.esterna Ext. coolant Aussenkuehlung	
DW 00730132	1	X	X	NEW

HYUNDAI-KIA (WIA)
 MOD: SKT160TTMS/TTSY (LM1600TTMS/TTSY) - SKT180TTMS/TTSY (LM1800TTMS/TTSY) (L230LMSA)

PORTAUTENSILE RADIALE PER LAMA
 Radial blade holder
 Radial Abstechhalter

<p>M.T. srl Via Casino Albini 480 Tel. 0541/956034-957884 Fax 0541/956341 47842 S. GIOVANNI IN M. (RN) e-mail: mtma@mtmarchetti.com http://www.mtmarchetti.com</p>	<p>PRODUZIONE MODULI ROTANTI</p> 
	<p>PAGINA KIA510-2-00</p>

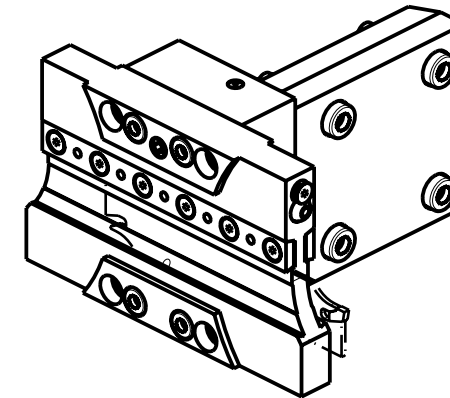
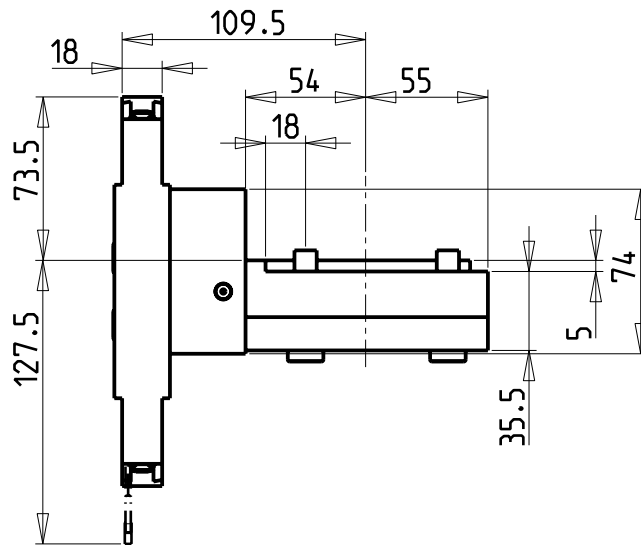
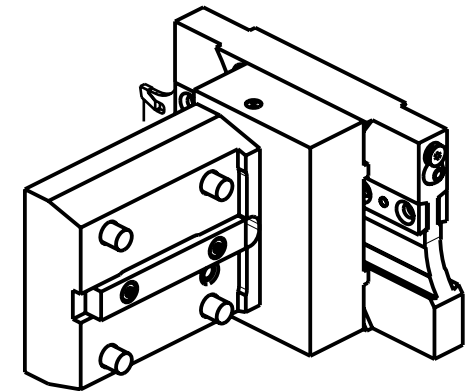
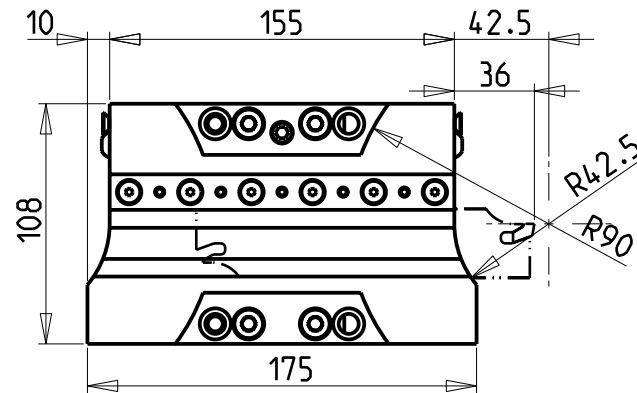
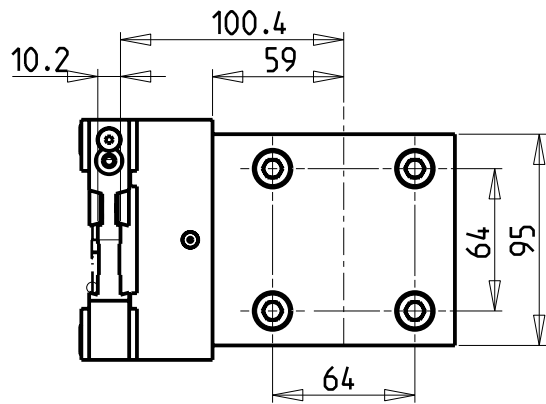

POSSIBILITA' DI LAVORO M3/M4
 OPTION OF M3/M4 WORKING
 ARBEITSMÖGLICHKEIT M3/M4

ATTENZIONE - ATTENTION - ACHTUNG

- FINO AD ESAURIMENTO SCORTE
- clearance sale
- solange vorrat

DOTAZIONI - SUPPLIED WITH - AUSSTATTUNG

- N°1 - LAMA - BLADE - KLINGE ISCAR H=32 Sp. 3/4mm (KENNAMETAL OPTIONAL)
- N°10 - INSERTI - INSERTS - EINLAGEN
- N°1 - CHIAVE A T PER MONTAGGIO INSERTI
 - T-WRENCH FOR INSERT SET UP
 - T-SCHLUESSEL FUER EINSATZSTUECK-MONTAGE

Cod. MT

N°Utensili
 N°Tools
 N°Werkzeuge

0790132

1

HYUNDAI-KIA (WIA)

MOD: SKT160TTMS/TTSY (LM1600TTMS/TTSY) - SKT180TTMS/TTSY (LM1800TTMS/TTSY) (L230LMSA)

PORTAUTENSILE PER LAMA DOPPIO

Radial double blade holder

Radial Doppel-Abstechhalter

M.T. srl

Via Casino Albini 480
 Tel. 0541/956034-957884
 Fax 0541/956341
 47842 S. GIOVANNI IN M. (RN)
 e-mail: mtma@mtmarchetti.com
 http://www.mtmarchetti.com

PRODUZIONE MODULI ROTANTI



PAGINA KIA520-2-00

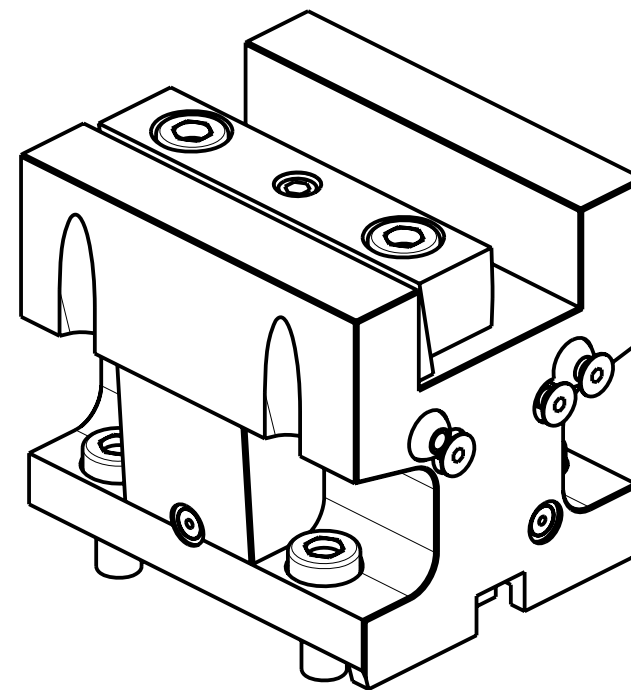
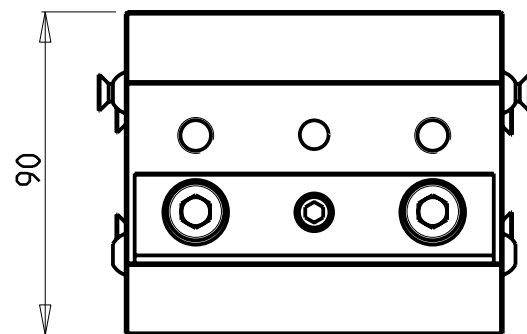
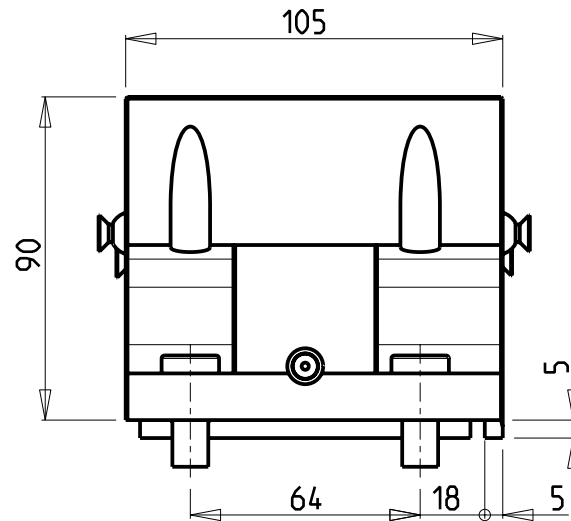
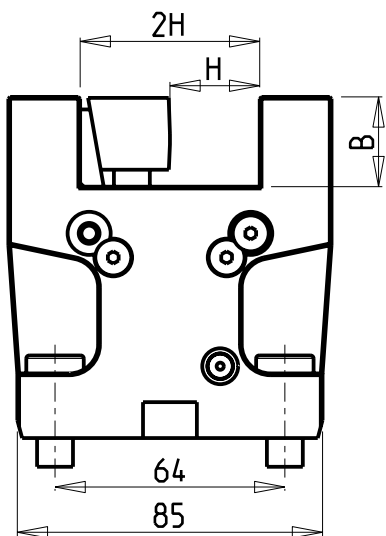

Cod. MT	N°Utensili N°Tools N°Werkzeuge	Reversibile lato mandrino/contromandrino Reversible sub/main spindle side Umkehrbare Spindel-seite/ Gegenspindel-seite	Misure Dimensions Masse	B	H
DW00422500	1	X	mm	25	25
DW00422540	1	X	Inch	1"	1"

HYUNDAI-KIA (WIA)

MOD: SKT160TTMS/TTSY (LM1600TTMS/TTSY) - SKT180TTMS/TTSY (LM1800TTMS/TTSY) (L230LMSA)

PORTAUTENSILE ASSIALE SINGOLO

Axial single static tool

Axial Single-Werkzeughalter

M.T. srl

Via Casino Albini 480
Tel. 0541/956034-957884
Fax 0541/956341
47842 S. GIOVANNI IN M. (RN)
e-mail: mtma@mtmarchetti.com
http://www.mtmarchetti.com

PRODUZIONE MODULI ROTANTI



PAGINA KIA552-2-00

PER BOCCOLE DI RIDUZIONE VEDI PAG. TBL150-1-00
 FOR REDUCING BUSHINGS SEE PAGE TBL150-1-00
 FÜR REDUZIERBUCHSE SIEHE SEITE TBL150-1-00

KIT ADDUZIONE INTERNA (OPZIONALE)
 KIT FOR INTERNAL COOLANT (OPTIONAL)
 KIT FÜR INTERNE KUEHLMITTELZUFUHR (OPTIONAL)
 $\varnothing 40$ cod. KIT1000003
 $\varnothing 1 \frac{1}{2}$ " cod. KIT1000004

ATTENZIONE - ATTENTION - ACHTUNG

FUORI VOLTEGGIO!
 OUT OF MAXIMUM SWING!
 WERKZEUG AUSSER INTERFERENZ!

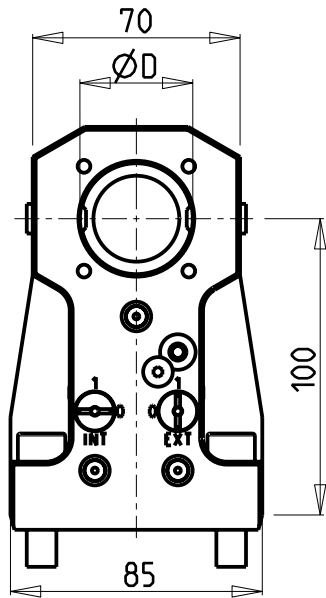
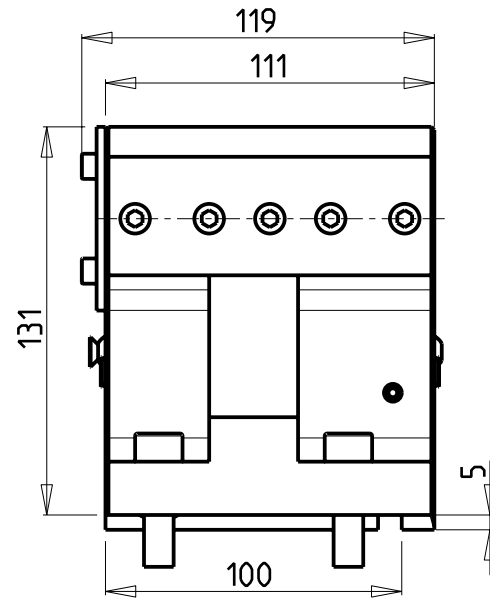
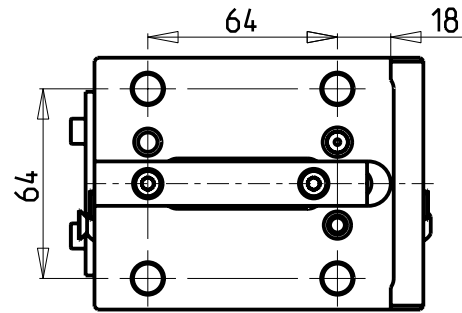
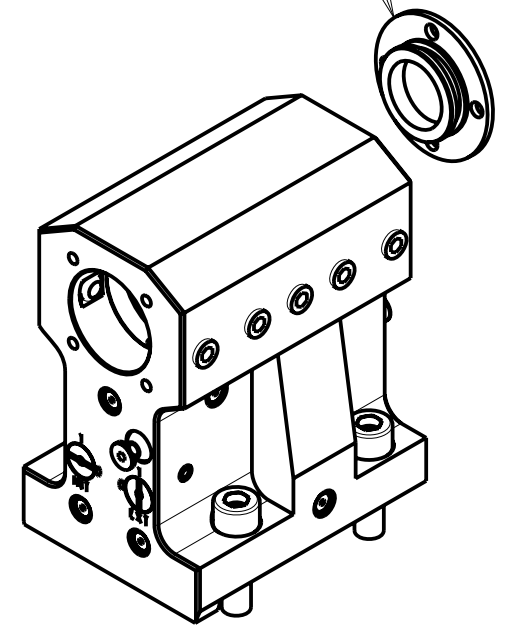

Cod. MT	N°Utensili N° Tools N° Werkzeuge	Reversibile lato mandrino/contromandrino Reversible sub/main spindle side Umkehrbare Spindel-seite/ Gegenspindel-seite	Lubrificazione int. opzionale Coolant through optional Innenkuehlung Optional	Lubrificazione est. Ext. coolant Aussenkuehlung	Misure Dimensions Masse	D
DW 00394000	1	X	X	X	mm	40
DW 00393810	1	X	X	X	Inch	1 1/2"

HYUNDAI-KIA (WIA)
 MOD: SKT160TTMS/TTSY (LM1600TTMS/TTSY) - SKT180TTMS/TTSY (LM1800TTMS/TTSY) (L230LMSA)

PORTAUTENSILE ASSIALE PER BARENO $\varnothing 40$ mm / $\varnothing 1 \frac{1}{2}$ " H=100mm
 Axial single boring bar holder $\varnothing 40$ mm / $\varnothing 1 \frac{1}{2}$ " H=100mm
 Axial Bohrhälter $\varnothing 40$ mm / $\varnothing 1 \frac{1}{2}$ " H=100mm

M.T. srl

Via Casino Albini 480
 Tel. 0541/956034-957884
 Fax 0541/956341
 47842 S. GIOVANNI IN M. (RN)
 e-mail: mtma@mtmarchetti.com
 http://www.mtmarchetti.com

PRODUZIONE MODULI ROTANTI



PAGINA KIA640-2-10

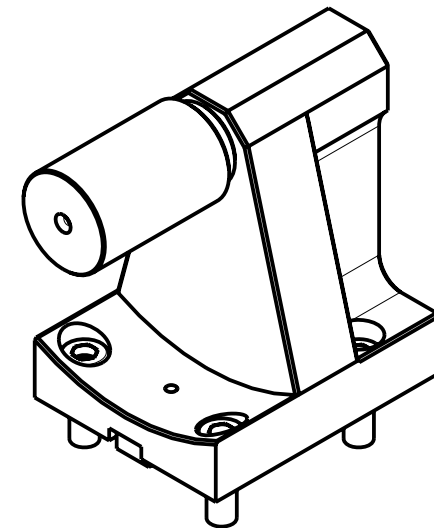
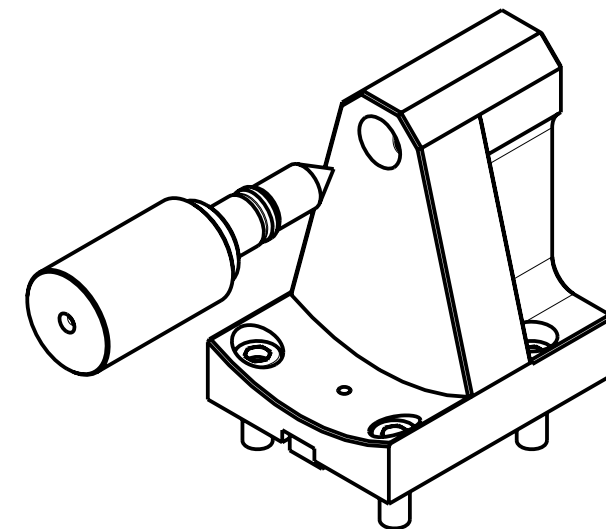
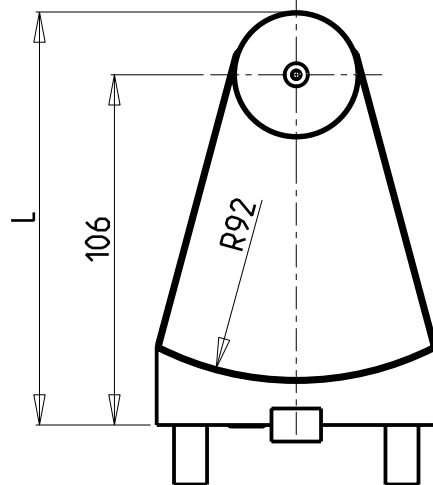
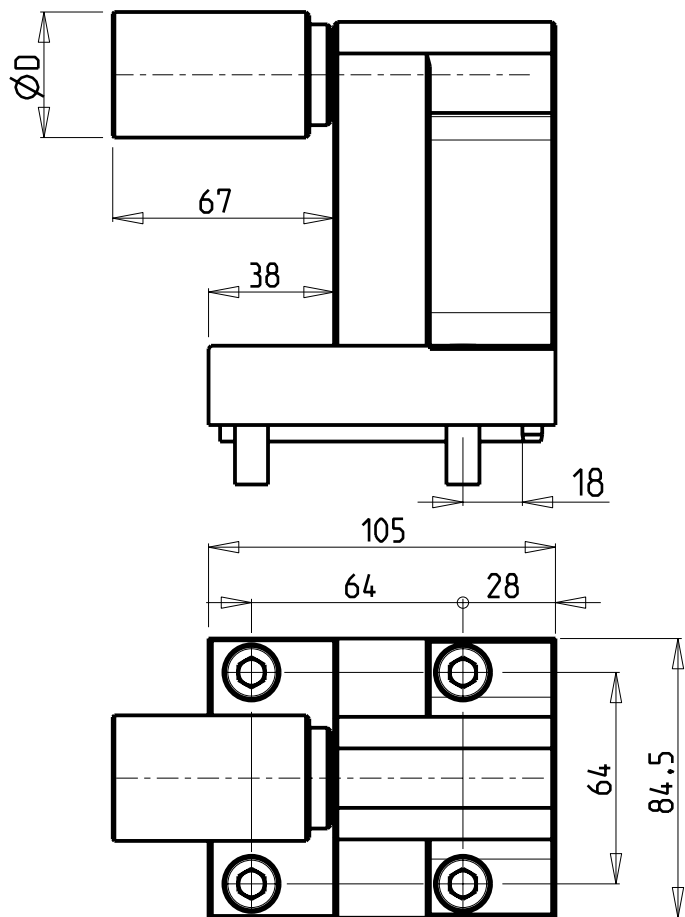

ATTENZIONE - ATTENTION - ACHTUNG

FUORI VOLTEGGIO!

OUT OF MAXIMUM SWING!

WERKZEUG AUSSER INTERFERENZ!

Cod. MT	N°Utensili N°Tools N°Werkzeuge	D	L
0820100	1	38	125
0820100L	1	2"	131.4

HYUNDAI-KIA (WIA)

MOD: SKT160TTMS/TTSY (LM1600TTMS/TTSY) - SKT180TTMS/TTSY (LM1800TTMS/TTSY) (L230LMSA)

CONTROPUNTA PER CONTROMANDRINO

Tailstock for subspindle

Gegenspitz fuer Gegenspindel

M.T. srl

Via Casino Albini 480
Tel. 0541/956034-957884
Fax 0541/956341
47842 S. GIOVANNI IN M. (RN)
e-mail: mtma@mtmarchetti.com
http://www.mtmarchetti.com

PRODUZIONE MODULI ROTANTI



PAGINA KIA950-2-00

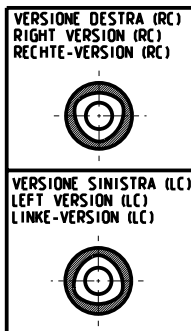
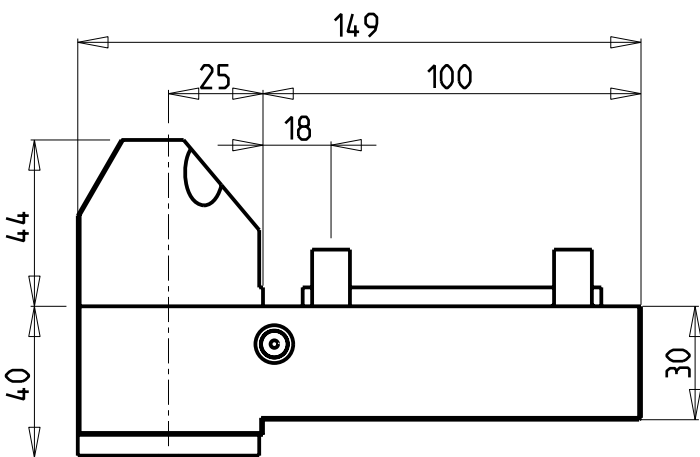
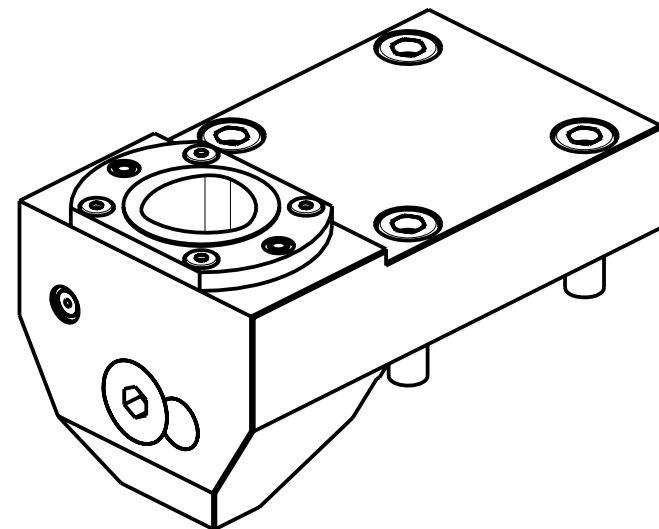
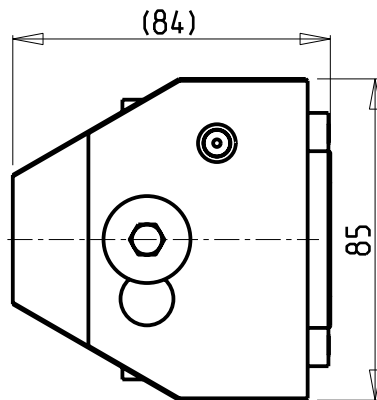
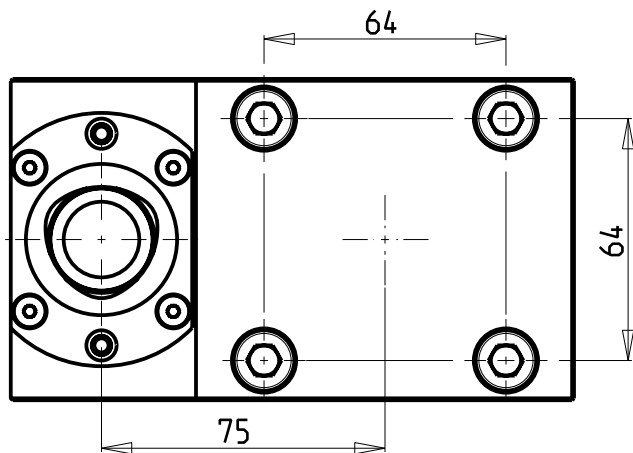

PER ORDINARE LA VERSIONE SX
AGGIUNGERE "LC" AL CODICE IN TABELLA.
ES: MNL0464010 DIVENTA MNL0464010LC

TO ORDER LEFT VERSION
ADD A "LC" IN THE CODE-CHARTS.
EXAMPLE: MNL0464010 BECOMES MNL0464010LC

UM DIE LINKE-VERSION ZU BESTELLEN, BEI DER
ARTIKELBEZEICHNUNG "LC" HINZUFUEGEN.
BEISPIEL: MNL0464010 WIRD DANN MNL0464010LC

Cod. MT	N°Utensili N°Tools N°Werkzeuge	Lubrificazione int. Coolant through Innenkuehlung	Reversibile lato mandrino/contromandrino Reversible sub/main spindle side Umkehrbare Spindelseite/ Gegenspindelseite	TAGLIA Size Masse
DW00444010	1	X	X	C4

HYUNDAI-KIA (WIA)

MOD: SKT160TTMS/TTSY (LM1600TTMS/TTSY) - SKT180TTMS/TTSY (LM1800TTMS/TTSY) (L230LMSA)

PORTAUTENSILE RADIALE SINGOLO ARRETRATO COROMANT CAPTO®

Radial rear-set single static tool COROMANT CAPTO®

Radial Single-Werkzeughalter zurueckversetzt COROMANT CAPTO®

M.T. srl

Via Casino Albini 480
Tel. 0541/956034-957884
Fax 0541/956341

47842 S. GIOVANNI IN M. (RN)
e-mail: mtma@mtmarchetti.com
http://www.mtmarchetti.com

PRODUZIONE MODULI ROTANTI



PAGINA KIA430-B-40

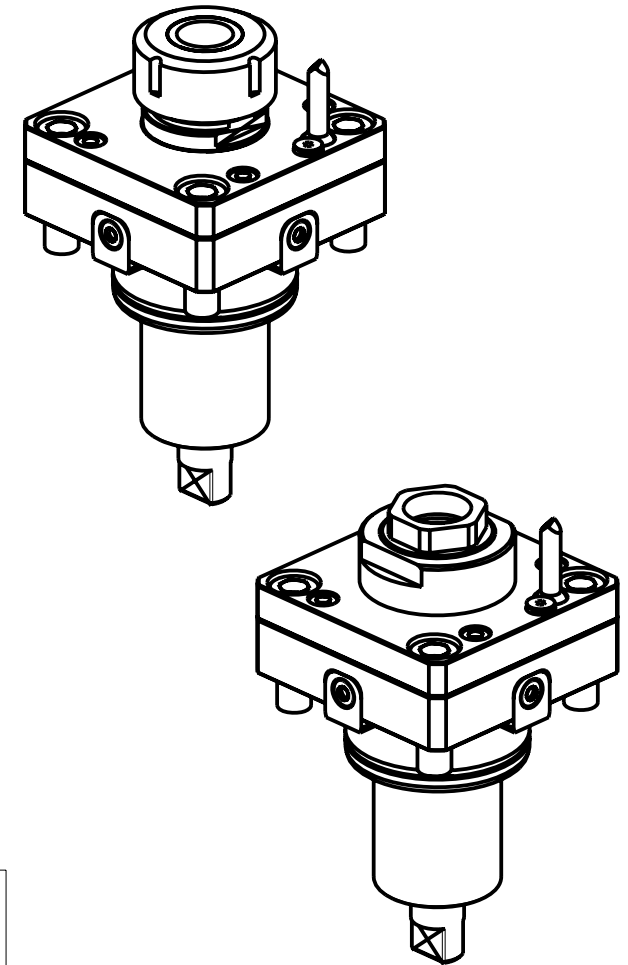
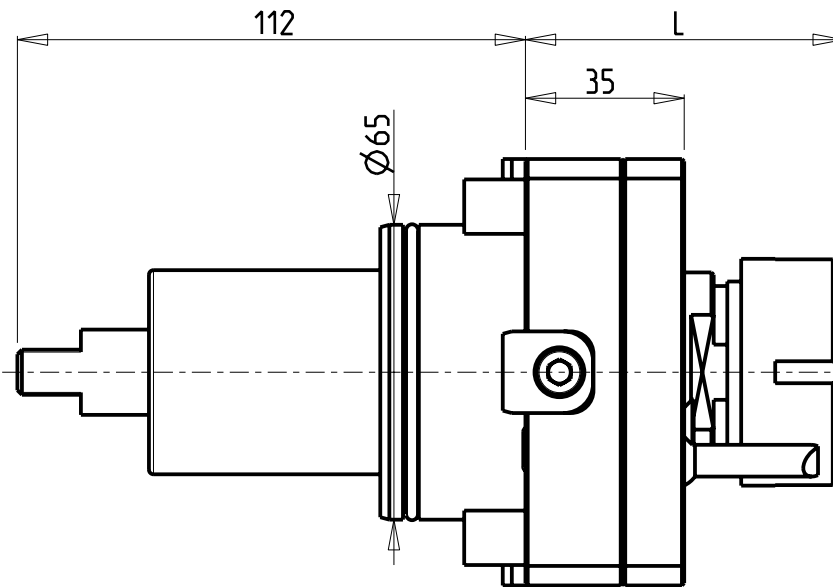
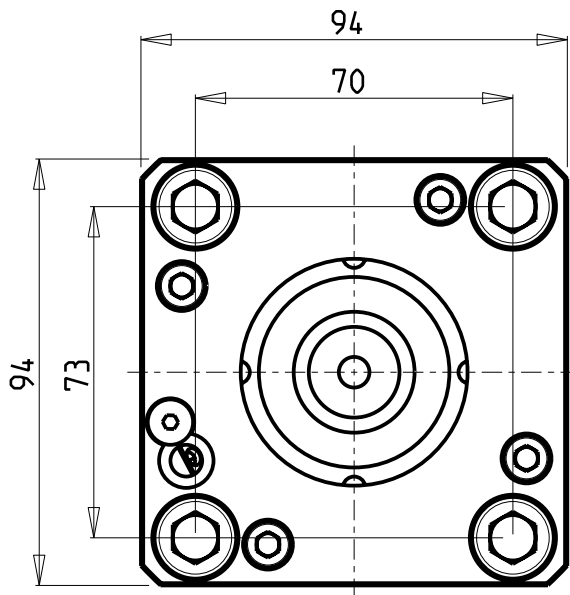

Cod. MT	Mandrino Spindel Spindel	I	RPM	Coppia Max Max Torque Max Drehmoment	Lubrificazione int. Coolant through Innenkuehlung	Lubrificazione est. Ext. coolant Aussenkuehlung	L	CHIAVI NON INCLUSE Keys not included Schluessel nicht einbegriffen	
0281532	ER32	1:1	6000	70Nm		X	70.06	CHSTER32	CHUB36 o 0280018
0281032	ER32	1:1	6000	70Nm	P=30bar		70.06	CHSTER32	CHUB36 o 0280018
0280132	ER A 32	1:1	6000	70Nm		X	64.26	CHUB32	CHUB36 o 0280018
0280232	ER A 32	1:1	6000	70Nm	P=30bar		70.53	CHUB32	CHUB36 o 0280018

HYUNDAI-KIA (WIA)
 SKT200TTM/TTMS/TTSY (LM2000TTM/TTMS/TTSY)
 SKT250TTM/TTMS/TTSY (LM2500TTM/TTMS/TTSY) - SKT250MS - SKT300MS (L300MSA)
 MODULO MOTORIZZATO RADIALE
 Radial driven tool
 Radial angetriebenes Werkzeug

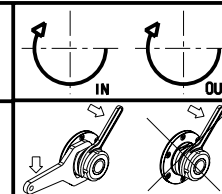

M.T. srl
 Via Casino Albini 480
 Tel. 0541/956034-957884
 Fax 0541/956341
 47842 S. GIOVANNI IN M. (RN)
 e-mail: mtma@mtmarchetti.com
 http://www.mtmarchetti.com

PRODUZIONE MODULI ROTANTI



PAGINA KIA010-3-00

CUSCINETTI MAGGIORATI PER LAVORAZIONI PESANTI

Reinforced bearings for
heavy machining

Vergroesserte Lager fuer
schwerere Bearbeitungen

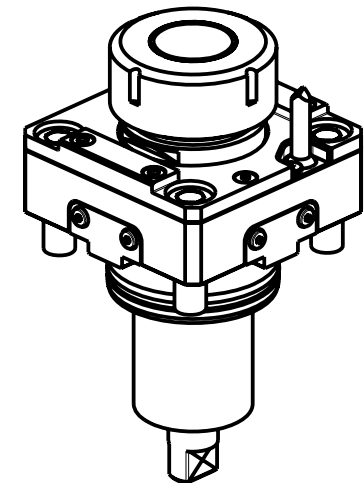
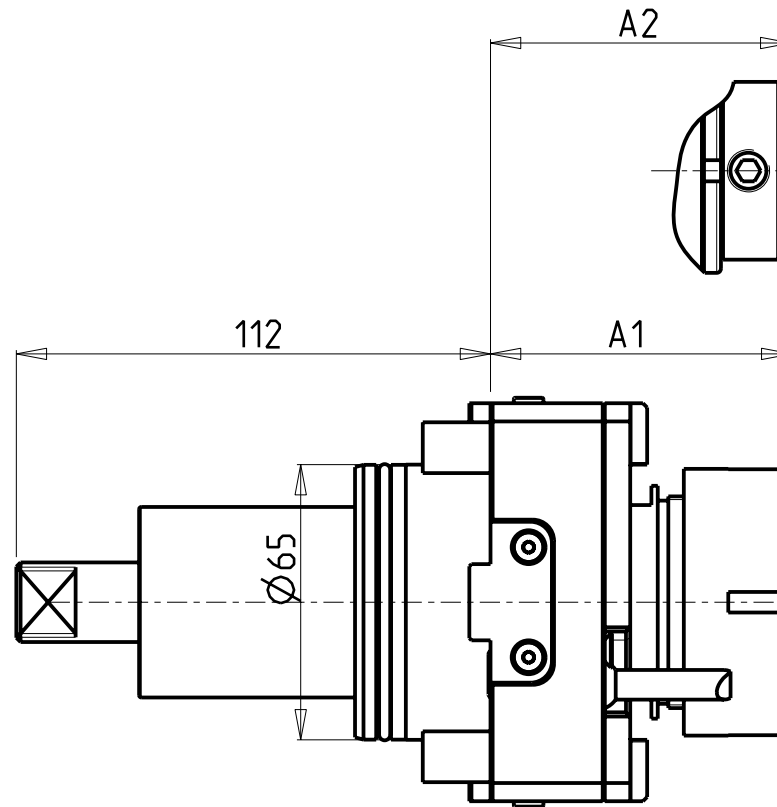
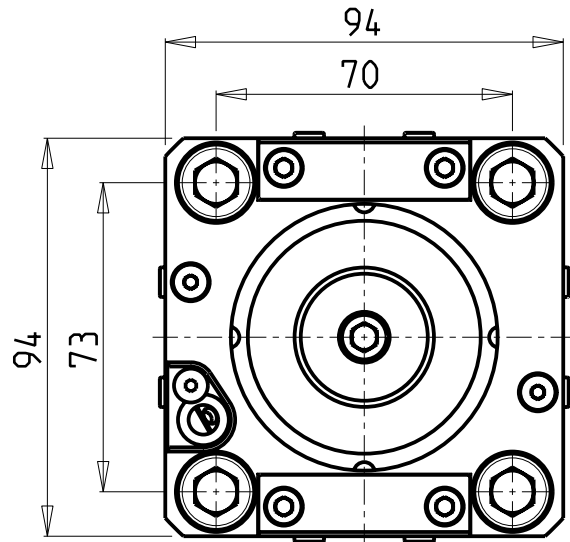

Cod. MT	Mandrino Spindle Spindel	I	RPM	Coppia Max Max Torque Max Drehmoment	Lubrificazione int. Coolant through Innenkuehlung	Lubrificazione est. Ext. coolant Aussenkuehlung	A1	A2	CHIAVI NON INCLUSE Keys not included Schluessel nicht einbegriffen	
DW00640140	ER40	1:1	6000	70Nm		X	71.16		CHSTER40	OKU0650004 ▪
DW00640240	ER40	1:1	6000	70Nm	P=30bar	X	82.16		CHSTER40	OKU0650004 ▪
DW00640625	WELDON25	1:1	6000	70Nm	P=30bar	X		72.5	-	-

- Chiave inclusa
- Key included
- Schluessel inbegriffen

HYUNDAI-KIA (WIA)
 SKT200TTM/TTMS/TTSY (LM2000TTM/TTMS/TTSY)
 SKT250TTM/TTMS/TTSY (LM2500TTM/TTMS/TTSY) - SKT250MS - SKT300MS (L300MSA)
 MODULO MOTORIZZATO RADIALE MAGGIORATO
 Radial reinforced driven tool
 Radial angetriebenes Werkzeug vergroessert

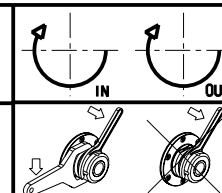

M.T. srl

Via Casino Albini 480
 Tel. 0541/956034-957884
 Fax 0541/956341
 47842 S. GIOVANNI IN M. (RN)
 e-mail: mtma@mtmarchetti.com
 http://www.mtmarchetti.com

PRODUZIONE MODULI ROTANTI



PAGINA KIA020-3-00

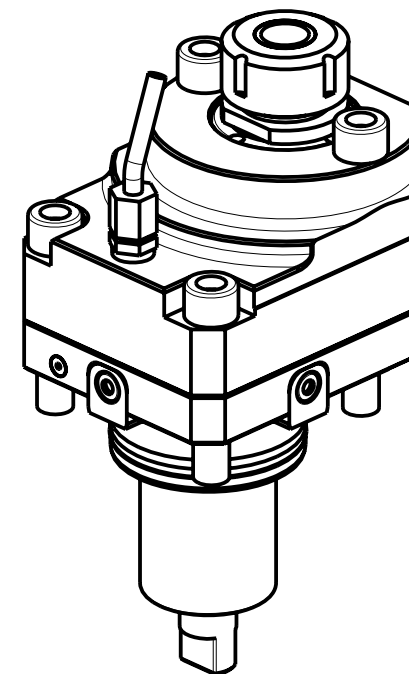
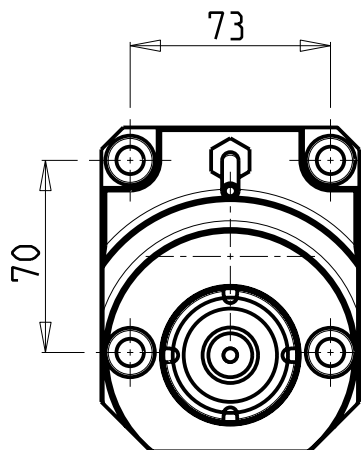
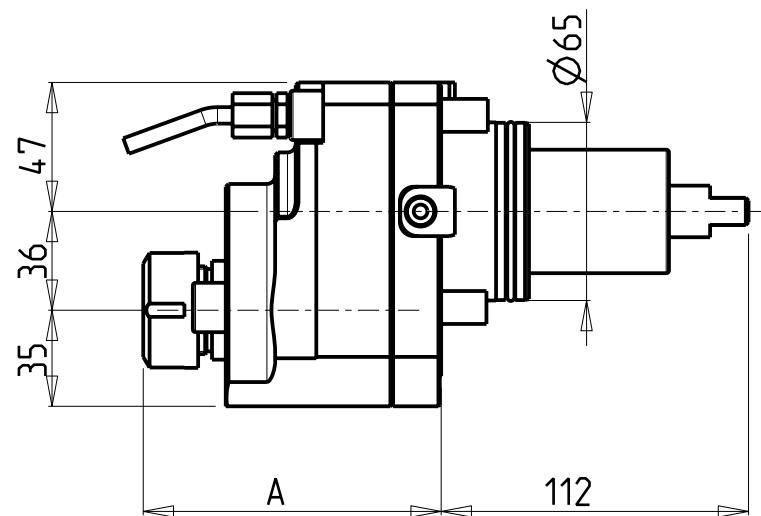
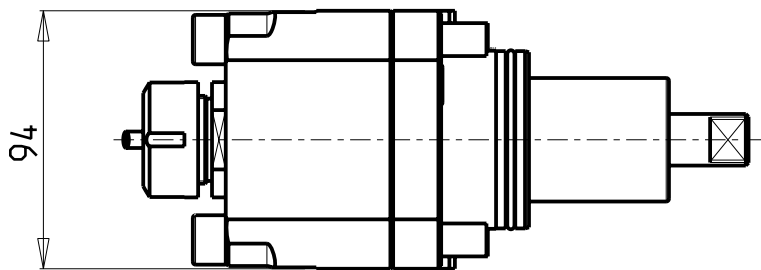

Cod. MT	Mandrino Spindle Spindel	I	RPM	Coppia Max Max Torque Max Drehmoment	Reversibile lato mandrino/contromandrino Reversible sub/main spindle side Umkehrbare Spindelseite/ Gegenspindelseite	Lubrificazione est. Ext. coolant Aussenkuehlung	A	CHIAVI NON INCLUSE Keys not included Schlüssel nicht einbegriffen
DW00140125	ER25	1:2	12000	30Nm	X	X	108.56	CHSTER25 MNL0210007

HYUNDAI-KIA (WIA)

SKT200TTM/TTMS/TTSY (LM2000TTM/TTMS/TTSY)
 SKT250TTM/TTMS/TTSY (LM2500TTM/TTMS/TTSY) - SKT250MS - SKT300MS (L300MSA)
 MODULO MOTORIZZATO RADIALE MOLTIPLICATO I=1:2 DISASSATO IN Z 36mm
 Radial geared-up I=1:2 driven tool re-directed in Z by 36mm
 Radial angetriebenes Werkzeug uebersetzt I=1:2 achsversetzt in Z um 36mm

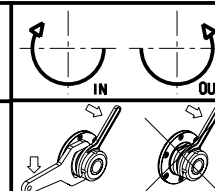

M.T. srl
 Via Casino Albini 480
 Tel. 0541/956034-957884
 Fax 0541/956341
 47842 S. GIOVANNI IN M. (RN)
 e-mail: mtma@mtmarchetti.com
 http://www.mtmarchetti.com

PRODUZIONE MODULI ROTANTI



PAGINA KIA030-3-30

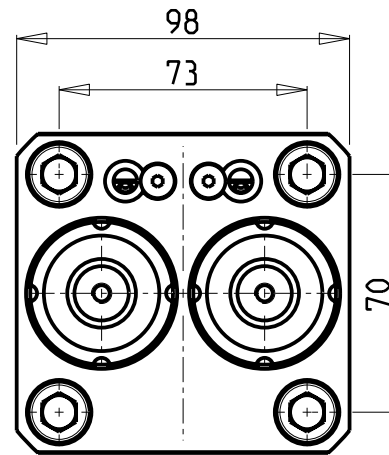
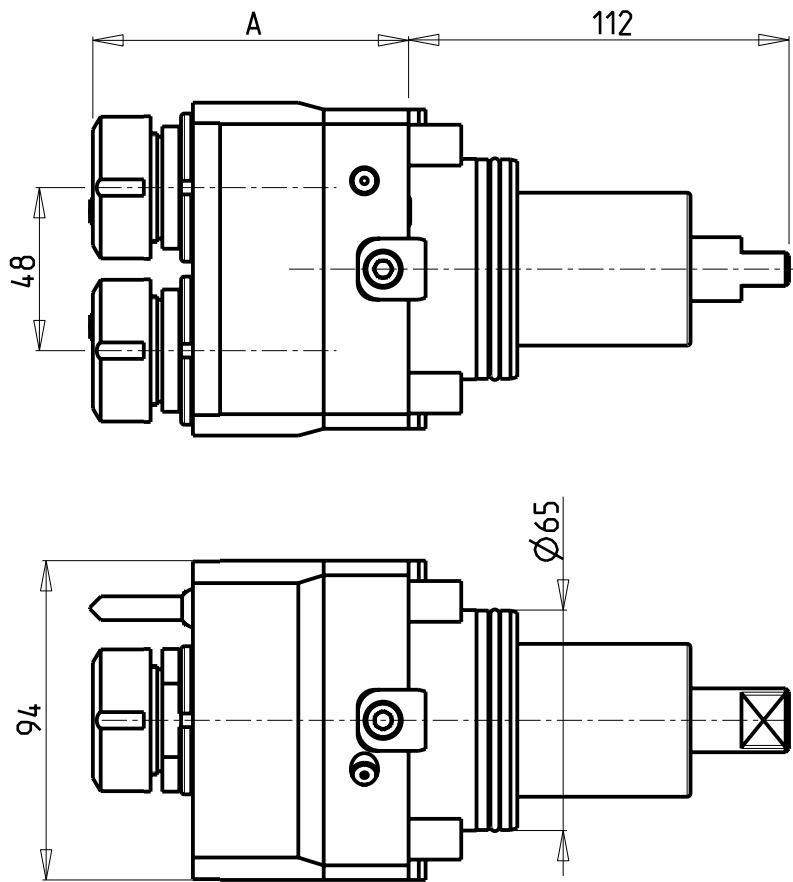

ATTENZIONE - ATTENTION - ACHTUNG

- Per lo smontaggio degli utensili utilizzare sempre la chiave di contrasto come indicato nel manuale d'uso.
- For disassembly of the tools use always the contrast key as mentioned in the user instructions.
- Fuer das Abmontieren der Werkzeuge immer den Gegenschlüssel benutzen wie in der Bedienungsanleitung erwäehnt.

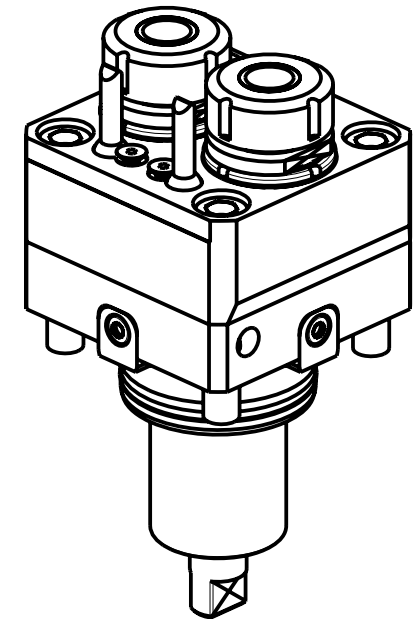

Cod. MT	Mandrino Spindle Spindel	I	RPM	Coppia Max Max Torque Max Drehmoment	Lubrificazione est. Ext. coolant Ausseukuehlung	A	CHIAVI NON INCLUDE Keys not included Schluessel nicht einbegriffen	
							CHMNER16	CHUB17
DW00540216	ER16	1:1	6000	30Nm	X	84.5	CHMNER16	CHUB17
DW00540225	ER25	1:1	6000	30Nm	X	85	CHSTER25	MNL0210007

HYUNDAI-KIA (WIA)

SKT200TTM/TTMS/TTSY (LM2000TTM/TTMS/TTSY)
SKT250TTM/TTMS/TTSY (LM2500TTM/TTMS/TTSY) - SKT250MS - SKT300MS (L300MSA)

MODULO MOTORIZZATO RADIALE 2 USCITE IN Y

Radial single side twin head driven tool in Y

Radial angetriebenes Werkzeug 2 Ausgaenge in Y

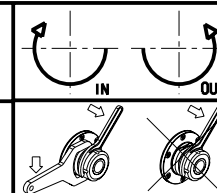

M.T. srl

Via Casino Albini 480
Tel. 0541/956034-957884
Fax 0541/956341
47842 S. GIOVANNI IN M. (RN)
e-mail: mtma@mtmarchetti.com
http://www.mtmarchetti.com

PRODUZIONE MODULI ROTANTI



PAGINA KIA080-3-00

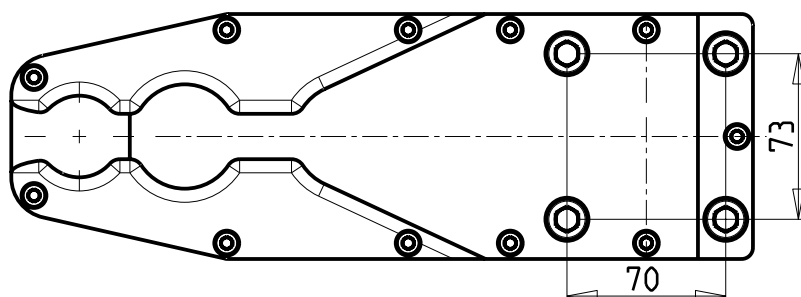
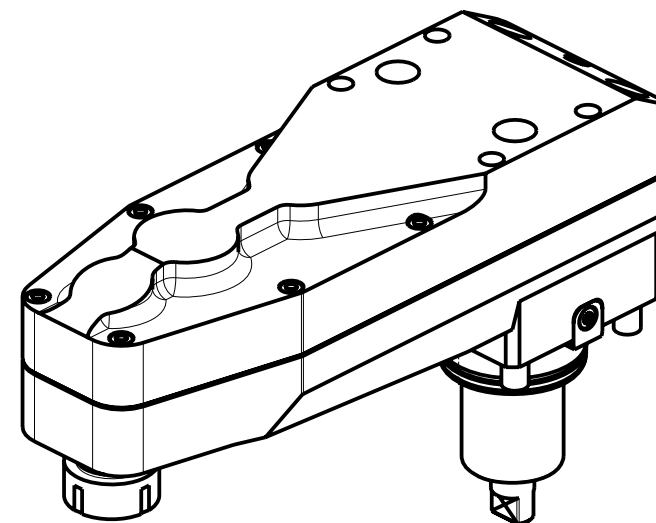
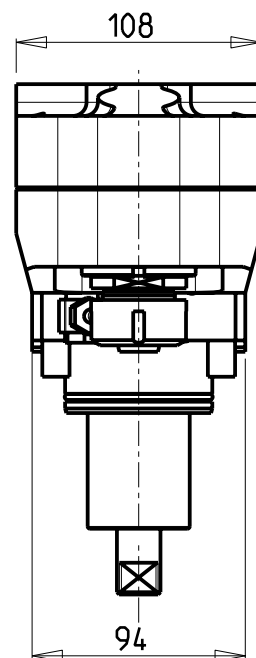
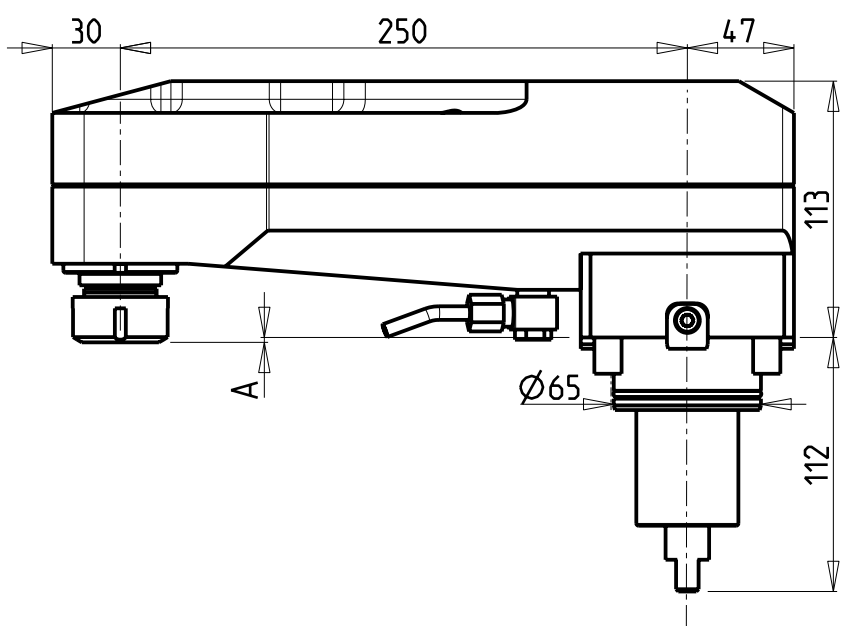

Cod. MT	Mandrino Spindle Spindel	I	RPM	Coppia Max Max Torque Max Drehmoment	Lubrificazione est. Ext. coolant Aussehenkuehlung	A	CHIAVI NON INCLUSE Keys not included Schlüssel nicht einbegriffen	
							CHSTER25	CHUB36
0700025	ER25	1:2	12000	30Nm	X	2.16	CHSTER25	CHUB36
0700032	ER32	1:2	12000	30Nm	X	14.66	CHSTER32	CHUB36

HYUNDAI-KIA (WIA)

SKT200TTM/TTMS/TTSY (LM2000TTM/TTMS/TTSY)
SKT250TTM/TTMS/TTSY (LM2500TTM/TTMS/TTSY) - SKT250MS - SKT300MS (L300MSA)

MODULO MOTORIZZATO RADIALE ROVESCiato INTERASSE DISASSATO IN Z 250mm

Radial inverted driven tool re-directed in Z by 250mm

Radial angetriebenes Werkzeug ungekehrt achsversetzt in Z um 250mm

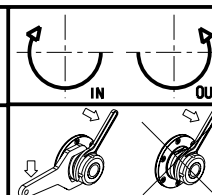

M.T. srl

Via Casino Albini 480
Tel. 0541/956034-957884
Fax 0541/956341

47842 S. GIOVANNI IN M. (RN)
e-mail: mtma@mtmarchetti.com
http://www.mtmarchetti.com

PRODUZIONE MODULI ROTANTI



PAGINA KIA120-3-10

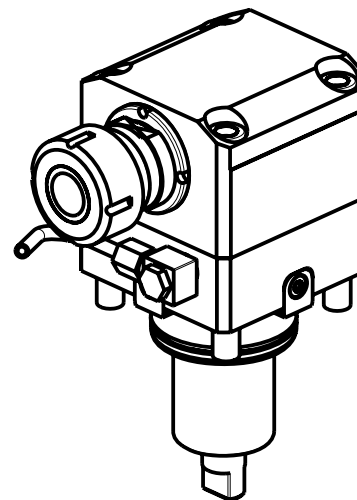
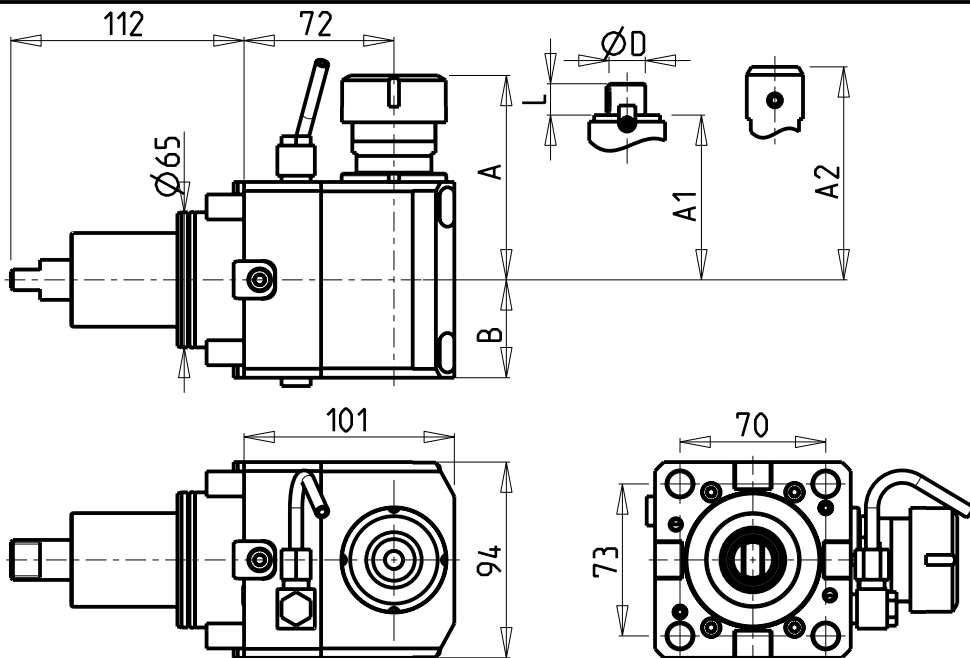

- Chiave inclusa
- Key included
- Schlüssel inbegriffen

Cod. MT	Mandrino Spindle Spindel	I	RPM	Coppia Max Max Torque Max Drehmoment	Reversibile lato mandrino/contromandrino Reversible sub/main spindle side Umkehrbare Spindel-seite/ Gegen-spindel-seite	Lubr.interna Coolant through Innenkuehlung	Lubr.esterna Ext. coolant Aussenkuehlung	A	A1	A2	B	D	L	CHIAVI NON INCLUSE Keys not included Schlüssel nicht einbegriffen	
														CHSTER32	CHUB36
0321432	ER32	1:1	6000	50Nm	X		X	98.16	-	-	47	-	-	CHSTER32	CHUB36
0321032	ER32	1:1	6000	50Nm	X	P=18bar	X	98.16	-	-	79	-	-	CHSTER32	CHUB36
0320022	WELDON 20	1:1	6000	50Nm	X		X	-	-	100	47	-	-		
0321617	Ø16x17	1:1	6000	50Nm	X		X	-	61	-	47	16	17	CH_VTCROCE_M08	CHUB36
0322219	Ø22x19	1:1	6000	50Nm	X		X	-	62	-	47	22	19	CH_VTCROCE_M10	CHUB36
0322240	Ø22x40	1:1	6000	50Nm	X		X	-	62	-	47	22	40	CH_VTCROCE_M10	CHUB36
0322721	Ø27x21	1:1	6000	50Nm	X		X	-	64	-	47	27	21	CH_VTCROCE_M12	CHUB36
0322733	Ø27x33	1:1	6000	50Nm	X		X	-	64	-	47	27	33	CH_VTCROCE_M12	CHUB36
0322750	Ø27x50	1:1	6000	50Nm	X		X	-	64	-	47	27	50	CH_VTCROCE_M12	CHUB36

HYUNDAI-KIA (WIA)
 SKT250MS - SKT300MS (L300MSA)
 MODULO MOTORIZZATO ASSIALE H=72mm
 Axial driven tool H=72mm
 Axial angetriebenes Werkzeug H=72mm

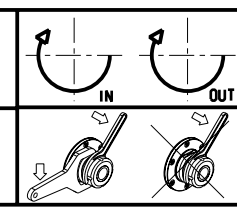

M.T. srl
 Via Casino Albini 480
 Tel. 0541/956034-957884
 Fax 0541/956341
 47842 S. GIOVANNI IN M. (RN)
 e-mail: mtma@mtmarchetti.com
 http://www.mtmarchetti.com

PRODUZIONE MODULI ROTANTI



PAGINA KIA150-3-10

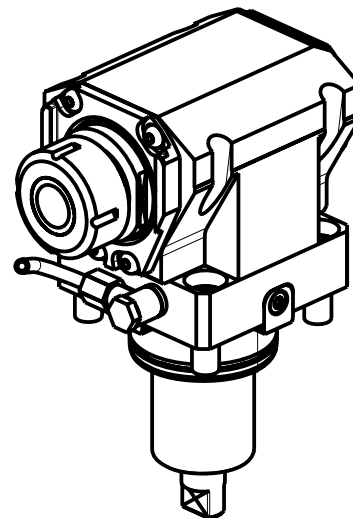
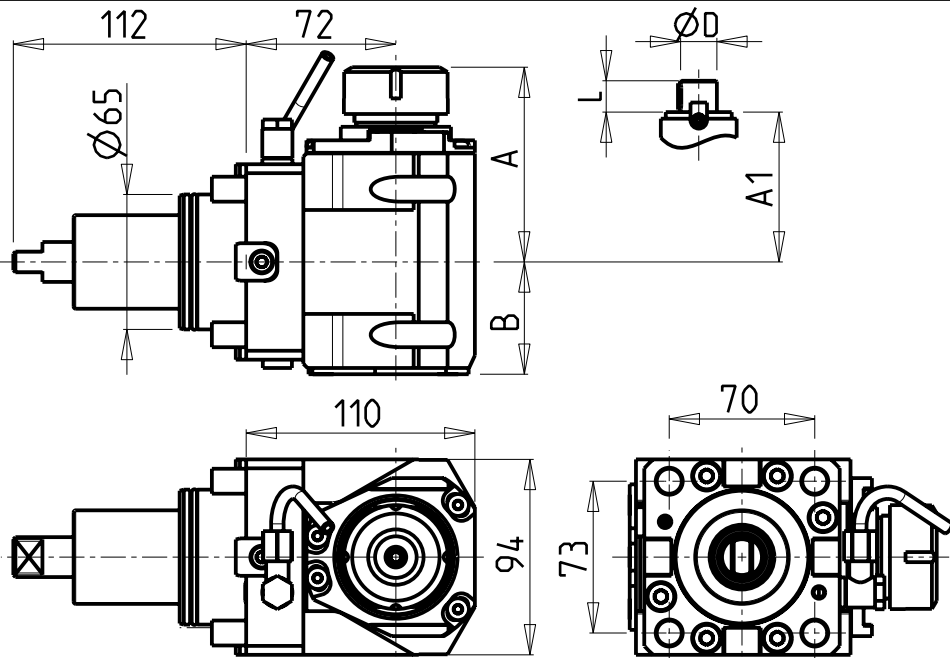

ATTENZIONE - ATTENTION - ACHTUNG

- Per lo smontaggio degli utensili utilizzare sempre la chiave di contrasto come indicato nel manuale d'uso.
- For disassembly of the tools use always the contrast key as mentioned in the user instructions.
- Fuer das Abmontieren der Werkzeuge immer den Gegenschluessel benutzen wie in der Bedienungsanleitung erwaeht.

- Chiave inclusa
- Key included
- Schluessel inbegriffen

Cod. MT	Mandrino Spindle Spindel	I	RPM	Coppia Max Max Torque Max Drehmoment	Reversibile lato mandrino/contromandrino Reversible sub/main spindle side Umkehrbare Spindel-seite/ Gegenspindel-seite	Lubr.interna Coolant through Innenkuehlung	Lubr.esterna Ext. coolant Aussenkuehlung	A	A1	B	D	L	CHIAVI NON INCLUSE Keys not included Schluessel nicht einbegriffen		
DW 00700125	ER25	1:1	6000	70Nm	X		X	91.16	-	54	-	-	CHSTER25	OKU0650004	NEW
DW 00700225	ER25	1:1	6000	70Nm	X	P=70bar	X	91.16	-	65	-	-	CHSTER25	OKU0650004	NEW
DW 00700132	ER32	1:1	6000	70Nm	X		X	93.66	-	54	-	-	CHSTER32	OKU0650004	NEW
DW 00700232	ER32	1:1	6000	70Nm	X	P=70bar	X	93.66	-	65	-	-	CHSTER32	OKU0650004	NEW
DW 00700140	ER40	1:1	6000	70Nm	X		X	98.16	-	54	-	-	CHSTER40	OKU0650004	NEW
DW 00700240	ER40	1:1	6000	70Nm	X	P=70bar	X	98.16	-	65	-	-	CHSTER40	OKU0650004	NEW
DW 00700516	Ø16x17	1:1	6000	70Nm	X		X	-	67.5	54	16	17	CH_VTCROCE_M08	OKU0650004	NEW
DW 00700522	Ø22x19	1:1	6000	70Nm	X		X	-	67.5	54	22	19	CH_VTCROCE_M10	OKU0650004	NEW
DW 00700527	Ø27x21	1:1	6000	70Nm	X		X	-	70	54	27	21	CH_VTCROCE_M12	OKU0650004	NEW

HYUNDAI-KIA (WIA)

SKT200TTM/TTMS/TTSY (LM2000TTM/TTMS/TTSY)
SKT250TTM/TTMS/TTSY (LM2500TTM/TTMS/TTSY) - SKT250MS - SKT300MS (L300MSA)

MODULO MOTORIZZATO ASSIALE H=72mm

Axial driven tool H=72mm

Axial angetriebenes Werkzeug H=72mm

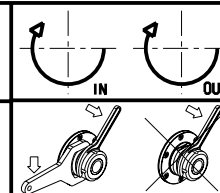

M.T. srl

Via Casino Albini 480
Tel. 0541/956034-957884
Fax 0541/956341
47842 S. GIOVANNI IN M. (RN)
e-mail: mtma@mtmarchetti.com
http://www.mtmarchetti.com

PRODUZIONE MODULI ROTANTI



PAGINA KIA150-3-11

ATTENZIONE - ATTENTION - ACHTUNG

- Per lo smontaggio degli utensili utilizzare sempre la chiave di contrasto come indicato nel manuale d'uso.
- For disassembly of the tools use always the contrast key as mentioned in the user instructions.
- Fuer das Abmontieren der Werkzeuge immer den Gegenschlüssel benutzen wie in der Bedienungsanleitung erwäehnt.

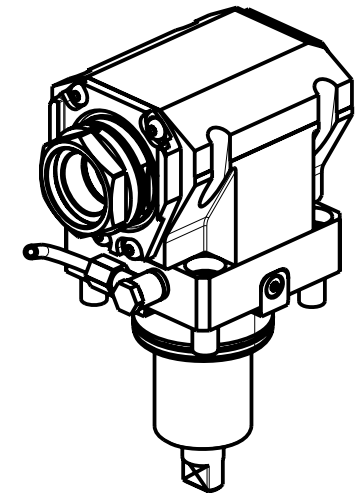
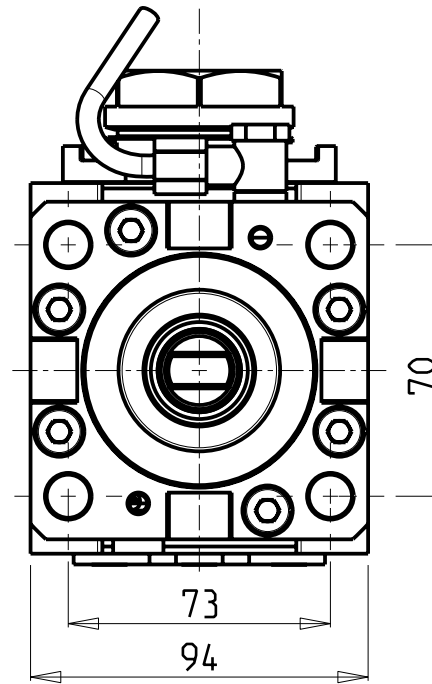
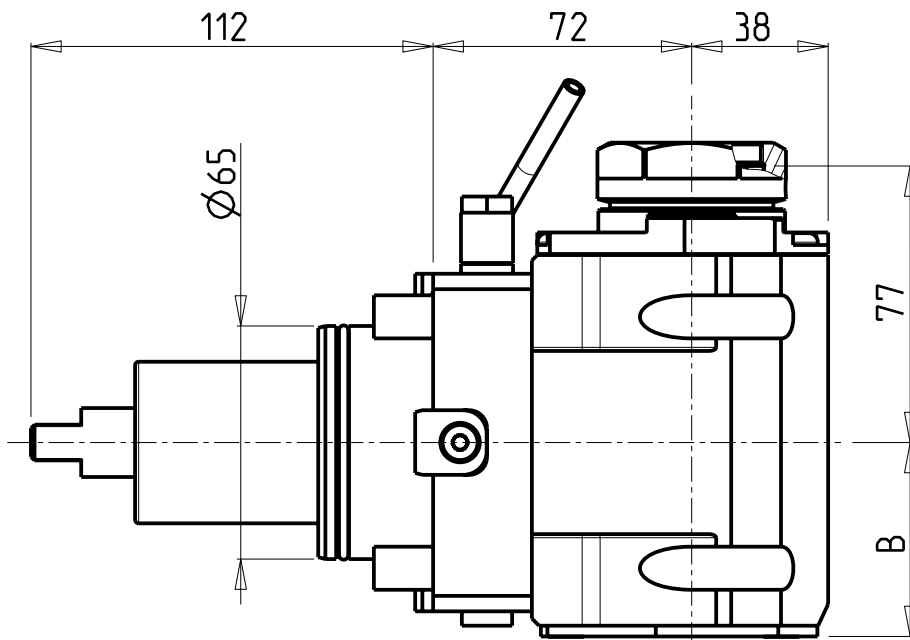

PER PORTAUTENSILI MODULARI MTSK-40 VEDI PAG. TBL300-1-40
 FOR MTSK-40 QUICK CHANGE TOOLHOLDERS CLAMPINGS SEE PAGE TBL300-1-40
 FUER MTSK-40 MODULARE WERKZEUGAUFNAHMEN SIEHE SEITE TBL300-1-40

Cod. MT	Mandrino Spindle Spindel	I	RPM	Coppia Max Max Torque Max Drehmoment	Reversibile lato mandrino/contromandrino Reversible sub/main spindle side Umkehrbare Spindel-seite/ Gegenspindel-seite	Lubr.interna Coolant through Innenkuehlung	Lubr.esterna Ext. coolant Ausseinkuehlung	B	CHIAVI NON INCLUSE Keys not included Schluesssel nicht einbegriffen	
DW01170140	MTSK-40	1:1	6000	70Nm	X		X	54	CHUB46	OKU0650004 *
DW01170240	MTSK-40	1:1	6000	70Nm	X	P=70bar	X	65	CHUB46	OKU0650004 *

- Chiave inclusa
- Key included
- Schluesssel inbegriffen

NEW
NEW

HYUNDAI-KIA (WIA)
 SKT200TTM/TTMS/TTSY (LM2000TTM/TTMS/TTSY)
 SKT250TTM/TTMS/TTSY (LM2500TTM/TTMS/TTSY) - SKT250MS - SKT300MS (L300MSA)
 MODULO MOTORIZZATO ASSIALE MTSK H=72mm
 Axial MTSK driven tool H=72mm
 Axial MTSK angetriebenes Werkzeug H=72mm

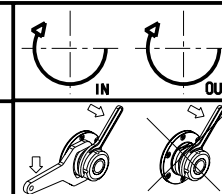

M.T. srl
 Via Casino Albini 480
 Tel. 0541/956034-957884
 Fax 0541/956341
 47842 S. GIOVANNI IN M. (RN)
 e-mail: mtma@mtmarchetti.com
 http://www.mtmarchetti.com

PRODUZIONE MODULI ROTANTI



PAGINA KIA150-3-11-K

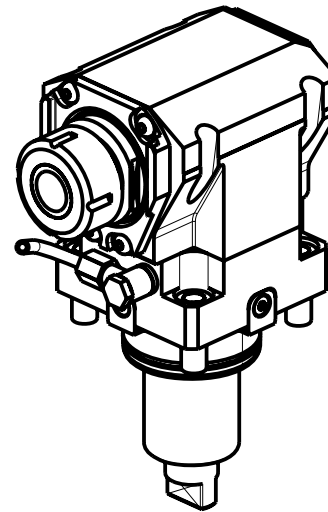
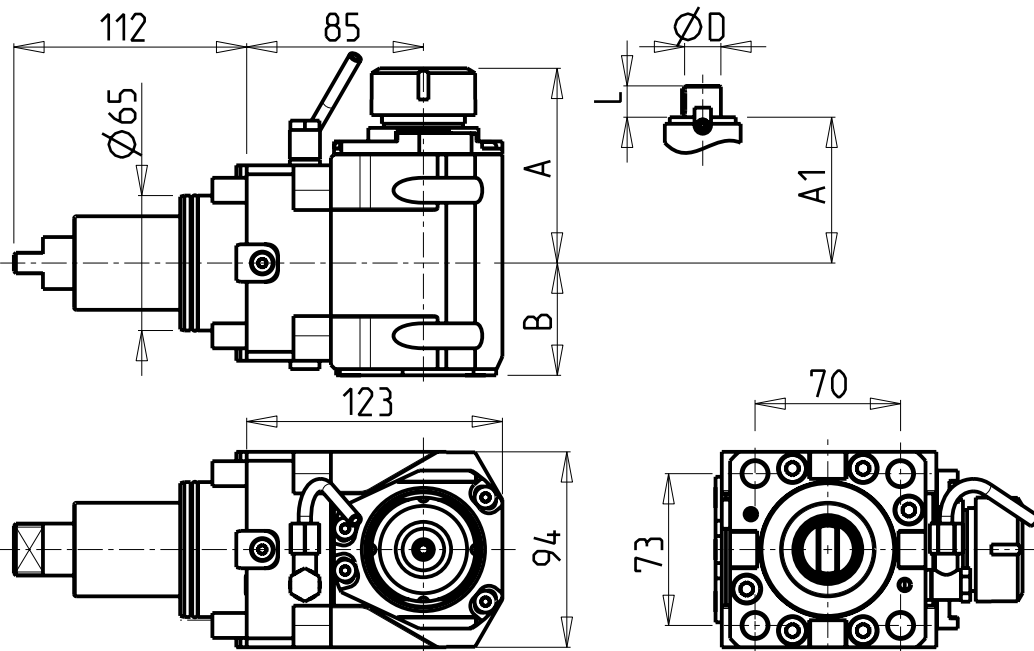

ATTENZIONE - ATTENTION - ACHTUNG

- Per lo smontaggio degli utensili utilizzare sempre la chiave di contrasto come indicato nel manuale d'uso.
- For disassembly of the tools use always the contrast key as mentioned in the user instructions.
- Fuer das Abmontieren der Werkzeuge immer den Gegenschlüssel benutzen wie in der Bedienungsanleitung erwäehnt.

- Chiave inclusa
- Key included
- Schlüssel inbegriffen

Cod. MT	Mandrino Spindle Spindel	I	RPM	Coppia Max Max Torque Max Drehmoment	Reversibile lato mandrino/contromandrino Reversible sub/main spindle side Umkehrbare Spindel-seite/ Gegenspindel-seite	Lubr.interna Coolant through Innenkuehlung	Lubr.esterna Ext. coolant Aussenkuehlung	A	A1	B	D	L	CHIAVI NON INCLUSE Keys not included Schlüssel nicht einbegriffen		
DW 01130125	ER25	1:1	6000	70Nm	X		X	91.16	-	54	-	-	CHSTER25	OKU0650004	NEW
DW 01130225	ER25	1:1	6000	70Nm	X	P=70bar	X	91.16	-	65	-	-	CHSTER25	OKU0650004	NEW
DW 01130132	ER32	1:1	6000	70Nm	X		X	93.66	-	54	-	-	CHSTER32	OKU0650004	NEW
DW 01130232	ER32	1:1	6000	70Nm	X	P=70bar	X	93.66	-	65	-	-	CHSTER32	OKU0650004	NEW
DW 01130140	ER40	1:1	6000	70Nm	X		X	98.16	-	54	-	-	CHSTER40	OKU0650004	NEW
DW 01130240	ER40	1:1	6000	70Nm	X	P=70bar	X	98.16	-	65	-	-	CHSTER40	OKU0650004	NEW
DW 01130516	Ø16x17	1:1	6000	70Nm	X		X	-	67.5	54	16	17	CH_VTCROCE_M08	OKU0650004	NEW
DW 01130522	Ø22x19	1:1	6000	70Nm	X		X	-	67.5	54	22	19	CH_VTCROCE_M10	OKU0650004	NEW
DW 01130527	Ø27x21	1:1	6000	70Nm	X		X	-	70	54	27	21	CH_VTCROCE_M12	OKU0650004	NEW

HYUNDAI-KIA (WIA)

SKT200TTM/TTMS/TTSY (LM2000TTM/TTMS/TTSY)
SKT250TTM/TTMS/TTSY (LM2500TTM/TTMS/TTSY) - SKT250MS - SKT300MS (L300MSA)

MODULO MOTORIZZATO ASSIALE H=85mm

Axial driven tool H=85mm

Axial angetriebenes Werkzeug H=85mm

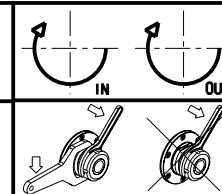

M.T. srl

Via Casino Albini 480
Tel. 0541/956034-957884
Fax 0541/956341
47842 S. GIOVANNI IN M. (RN)
e-mail: mtma@mtmarchetti.com
http://www.mtmarchetti.com

PRODUZIONE MODULI ROTANTI



PAGINA KIA150-3-15

ATTENZIONE - ATTENTION - ACHTUNG

- Per lo smontaggio degli utensili utilizzare sempre la chiave di contrasto come indicato nel manuale d'uso.
- For disassembly of the tools use always the contrast key as mentioned in the user instructions.
- Fuer das Abmontieren der Werkzeuge immer den Gegenschlüssel benutzen wie in der Bedienungsanleitung erwäehnt.

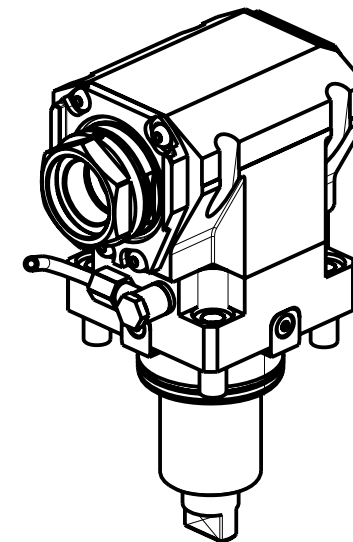
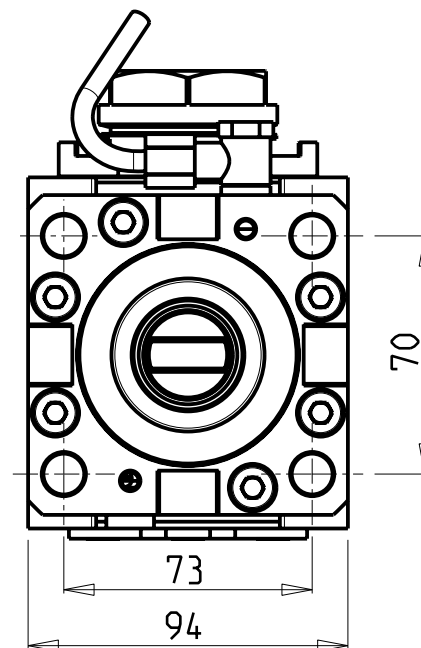
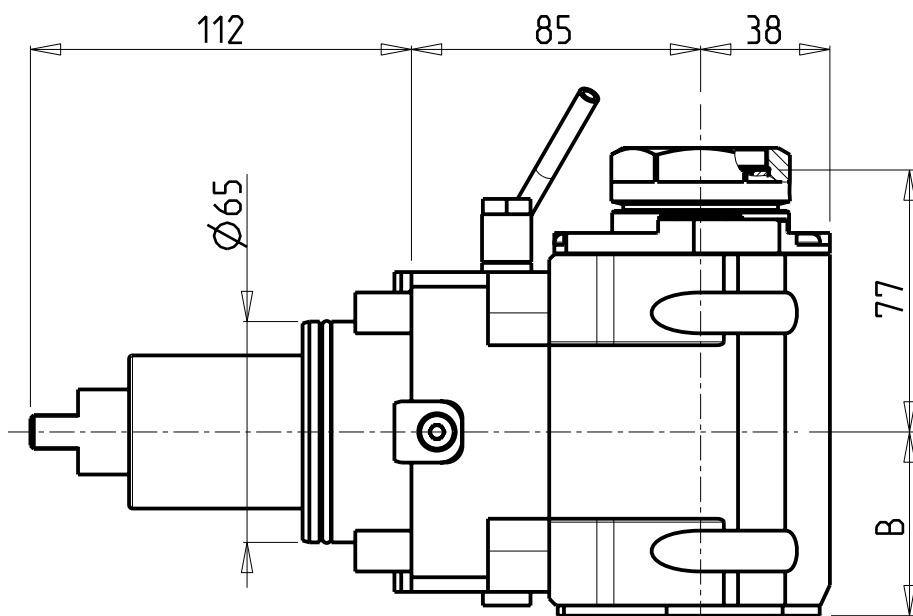

PER PORTAUTENSILI MODULARI MTSK-40 VEDI PAG. TBL300-1-40
 FOR MTSK-40 QUICK CHANGE TOOLHOLDERS CLAMPINGS SEE PAGE TBL300-1-40
 FUER MTSK-40 MODULARE WERKZEUGAUFNAHMEN SIEHE SEITE TBL300-1-40

Cod. MT	Mandrino Spindle Spindel	I	RPM	Coppia Max Max Torque Max Drehmoment	Reversibile lato mandrino/contromandrino Reversible sub/main spindle side Umkehrbare Spindel-seite/ Gegenspindel-seite	Lubr.interna Coolant through Innenkuehlung	Lubr.esterna Ext. coolant Ausseinkuehlung	B	CHIAVI NON INCLUSE Keys not included Schluesssel nicht einbegriffen	
DW01180140	MTSK-40	1:1	6000	70Nm	X		X	54	CHUB46	OKU0650004 •
DW01180240	MTSK-40	1:1	6000	70Nm	X	P=70bar	X	65	CHUB46	OKU0650004 •

- Chiave inclusa
- Key included
- Schluesssel inbegriffen

NEW
NEW

HYUNDAI-KIA (WIA)

SKT200TTM/TTMS/TTSY (LM2000TTM/TTMS/TTSY)
 SKT250TTM/TTMS/TTSY (LM2500TTM/TTMS/TTSY) - SKT250MS - SKT300MS (L300MSA)

MODULO MOTORIZZATO ASSIALE MTSK H=85mm

Axial MTSK driven tool H=85mm

Axial MTSK angetriebenes Werkzeug H=85mm

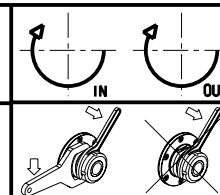

M.T. srl

Via Casino Albini 480
 Tel. 0541/956034-957884
 Fax 0541/956341
 47842 S. GIOVANNI IN M. (RN)
 e-mail: mtma@mtmarchetti.com
 http://www.mtmarchetti.com

PRODUZIONE MODULI ROTANTI



PAGINA KIA150-3-15-K

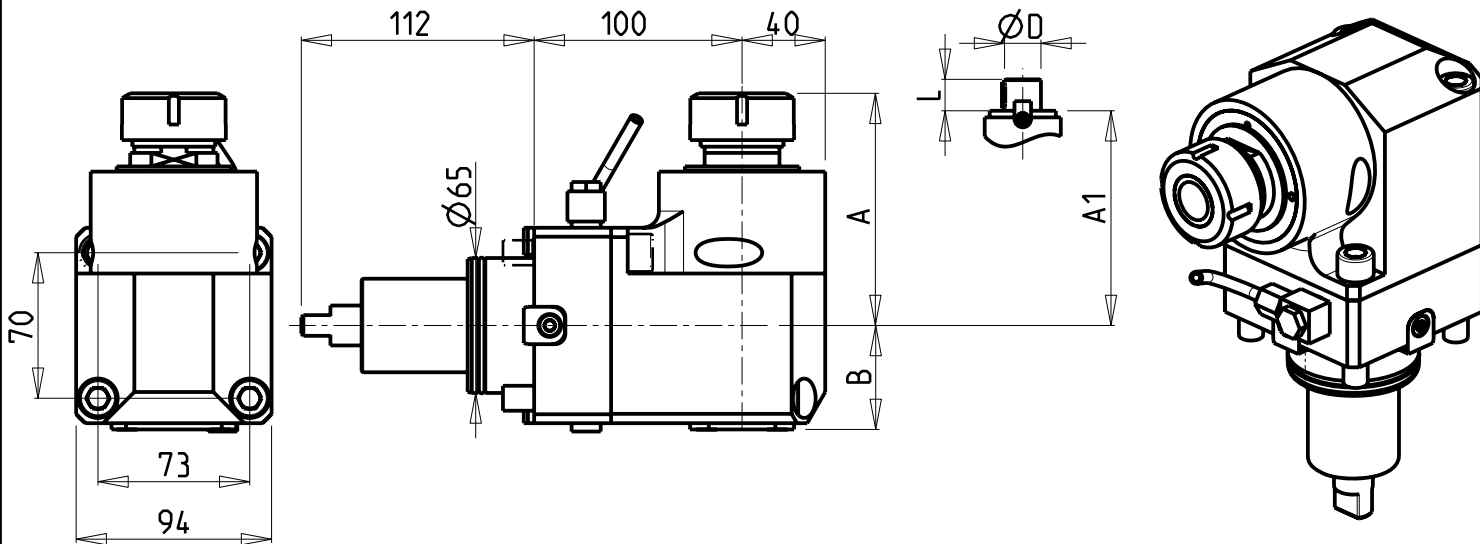

- Chiave inclusa
- Key included
- Schlüssel inbegriffen

Cod. MT	Mandrino Spindle Spindel	I	RPM	Coppia Max Max Torque Max Drehmoment	Reversibile lato mandrino/contromandrino Reversible sub/main spindle side Umkehrbare Spindelsetseite/Gegenspindelsetseite	Lubr.interna Coolant through Innenkuehlung	Lubr.esterna Ext. coolant Aussenkuehlung	A	B	A1	D	L	CHIAVI NON INCLUDE Keys not included Schluessel nicht einbegriffen	
													CHSTER32	CHUB36
0711432	ER32	1:1	6000	70Nm	X		X	111.56	47	-	-	-	CHSTER32	CHUB36
0711032	ER32	1:1	6000	70Nm	X	P=70bar	X	111.56	72	-	-	-	CHSTER32	CHUB36
0712640	ER40	1:1	6000	70Nm	X		X	115	47	-	-	-	CHSTER40	CHUB46
0712540	ER40	1:1	6000	70Nm	X	P=70bar	X	115	72	-	-	-	CHSTER40	CHUB46
0711617	Ø16x17	1:1	6000	70Nm	X		X	-	47	86	16	17	CH_VTCROCE_M08	CHUB36
0712219	Ø22x19	1:1	6000	70Nm	X		X	-	47	88	22	19	CH_VTCROCE_M10	CHUB36
0712240	Ø22x40	1:1	6000	70Nm	X		X	-	47	86	22	40	CH_VTCROCE_M10	CHUB36
0712721	Ø27x21	1:1	6000	70Nm	X		X	-	47	87.5	27	21	CH_VTCROCE_M12	CHUB36
0712733	Ø27x33	1:1	6000	70Nm	X		X	-	47	86	27	33	CH_VTCROCE_M12	CHUB36
0712750	Ø27x50	1:1	6000	70Nm	X		X	-	47	86	27	50	CH_VTCROCE_M12	CHUB36

HYUNDAI-KIA (WIA)
 SKT200TTM/TTMS/TTSY (LM2000TTM/TTMS/TTSY)
 SKT250TTM/TTMS/TTSY (LM2500TTM/TTMS/TTSY) - SKT250MS - SKT300MS (L300MSA)
 MODULO MOTORIZZATO ASSIALE H=100mm
 Axial driven tool H=100mm
 Axial angetriebenes Werkzeug H=100mm

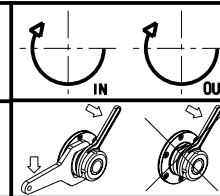

M.T. srl
 Via Casino Albini 480
 Tel. 0541/956034-957884
 Fax 0541/956341
 47842 S. GIOVANNI IN M. (RN)
 e-mail: mtma@mtmarchetti.com
 http://www.mtmarchetti.com

PRODUZIONE MODULI ROTANTI



PAGINA KIA150-3-20

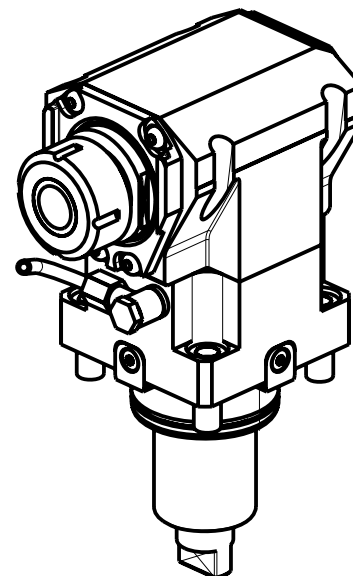
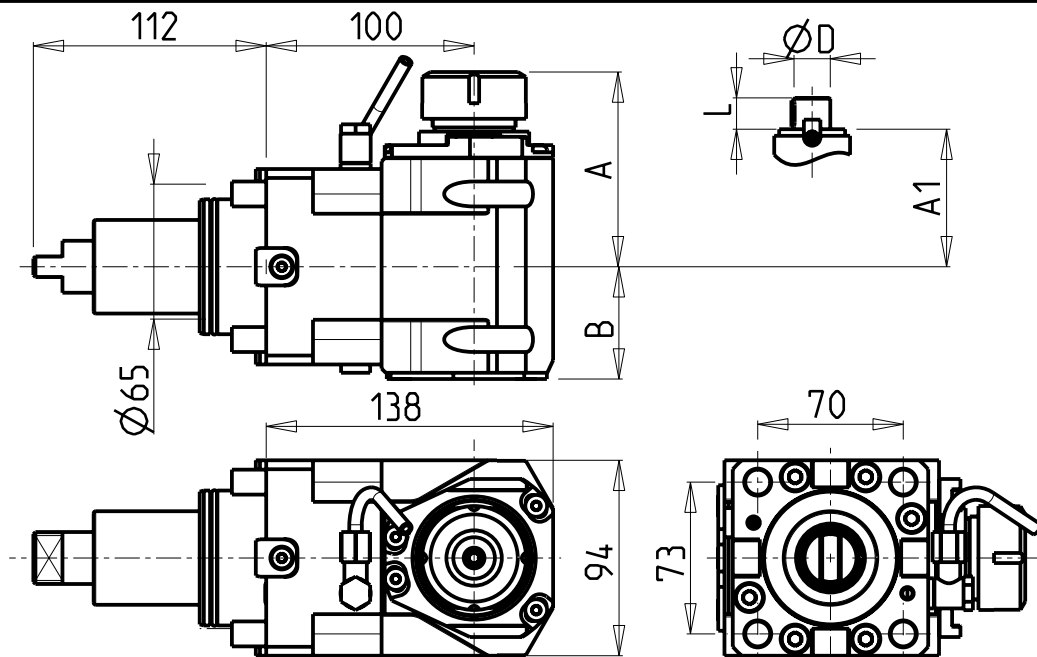

ATTENZIONE - ATTENTION - ACHTUNG

- Per lo smontaggio degli utensili utilizzare sempre la chiave di contrasto come indicato nel manuale d'uso.
- For disassembly of the tools use always the contrast key as mentioned in the user instructions.
- Fuer das Abmontieren der Werkzeuge immer den Gegenschlüssel benutzen wie in der Bedienungsanleitung erwahnt.

- Chiave inclusa
- Key included
- Schlüssel inbegriffen

Cod. MT	Mandrino Spindle Spindel	I	RPM	Coppia Max Max Torque Max Drehmoment	Reversibile lato mandrino/contromandrino Reversible sub/main spindle side Umkehrbare Spindel-seite/ Gegenspindel-seite	Lubr.interna Coolant through Innenkuehlung	Lubr.esterna Ext. coolant Aussenkuehlung	A	A1	B	D	L	CHIAVI NON INCLUSE Keys not included Schluessel nicht einbegriffen		
DW 01140125	ER25	1:1	6000	70Nm	X		X	91.16	-	54	-	-	CHSTER25	OKU0650004	NEW
DW 01140225	ER25	1:1	6000	70Nm	X	P=70bar	X	91.16	-	65	-	-	CHSTER25	OKU0650004	NEW
DW 01140132	ER32	1:1	6000	70Nm	X		X	93.66	-	54	-	-	CHSTER32	OKU0650004	NEW
DW 01140232	ER32	1:1	6000	70Nm	X	P=70bar	X	93.66	-	65	-	-	CHSTER32	OKU0650004	NEW
DW 01140140	ER40	1:1	6000	70Nm	X		X	98.16	-	54	-	-	CHSTER40	OKU0650004	NEW
DW 01140240	ER40	1:1	6000	70Nm	X	P=70bar	X	98.16	-	65	-	-	CHSTER40	OKU0650004	NEW
DW 01140516	Ø16x17	1:1	6000	70Nm	X		X	-	67.5	54	16	17	CH_VTCROCE_M08	OKU0650004	NEW
DW 01140522	Ø22x19	1:1	6000	70Nm	X		X	-	67.5	54	22	19	CH_VTCROCE_M10	OKU0650004	NEW
DW 01140527	Ø27x21	1:1	6000	70Nm	X		X	-	70	54	27	21	CH_VTCROCE_M12	OKU0650004	NEW

HYUNDAI-KIA (WIA)

SKT200TTM/TTMS/TTSY (LM2000TTM/TTMS/TTSY)
SKT250TTM/TTMS/TTSY (LM2500TTM/TTMS/TTSY) - SKT250MS - SKT300MS (L300MSA)

MODULO MOTORIZZATO ASSIALE H=100mm

Axial driven tool H=100mm

Axial angetriebenes Werkzeug H=100mm

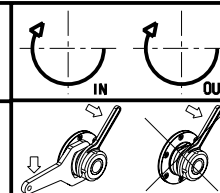

M.T. srl

Via Casino Albini 480
Tel. 0541/956034-957884
Fax 0541/956341
47842 S. GIOVANNI IN M. (RN)
e-mail: mtma@mtmarchetti.com
http://www.mtmarchetti.com

PRODUZIONE MODULI ROTANTI



PAGINA KIA150-3-21

ATTENZIONE - ATTENTION - ACHTUNG

- Per lo smontaggio degli utensili utilizzare sempre la chiave di contrasto come indicato nel manuale d'uso.
- For disassembly of the tools use always the contrast key as mentioned in the user instructions.
- Fuer das Abmontieren der Werkzeuge immer den Gegenschlüssel benutzen wie in der Bedienungsanleitung erwäehnt.

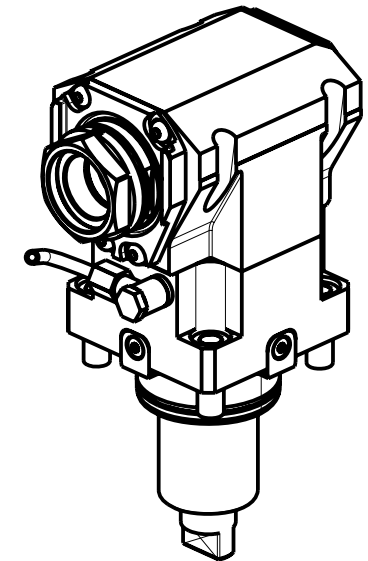
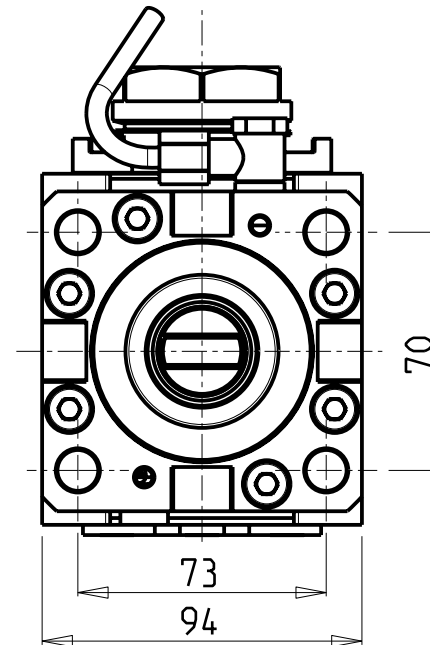
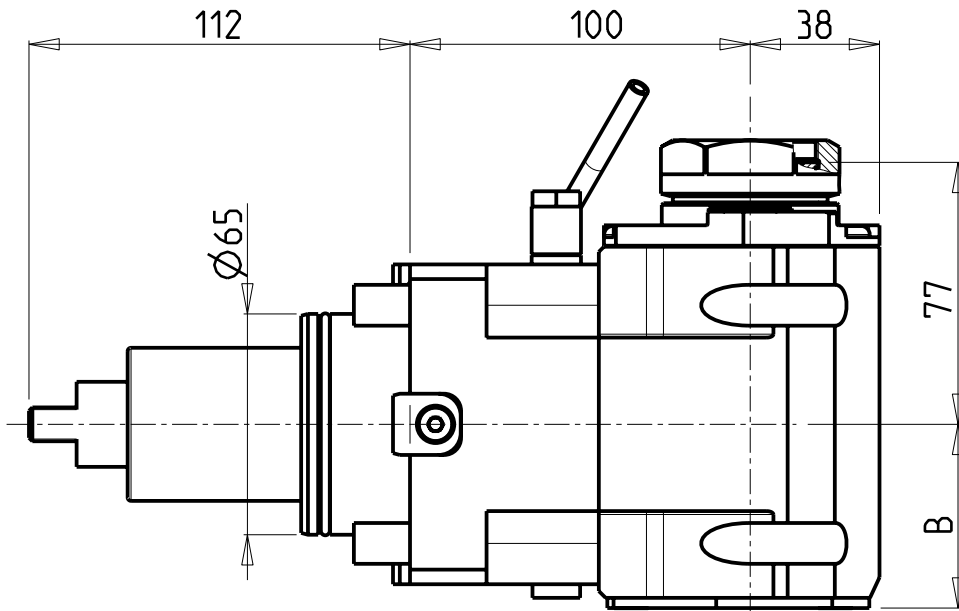

PER PORTAUTENSILI MODULARI MTSK-40 VEDI PAG. TBL300-1-40
 FOR MTSK-40 QUICK CHANGE TOOLHOLDERS CLAMPINGS SEE PAGE TBL300-1-40
 FUER MTSK-40 MODULARE WERKZEUGAUFNAHMEN SIEHE SEITE TBL300-1-40

Cod. MT	Mandrino Spindle Spindel	I	RPM	Coppia Max Max Torque Max Drehmoment	Reversibile lato mandrino/contromandrino Reversible sub/main spindle side Umkehrbare Spindel-seite/ Gegenspindel-seite	Lubr.interna Coolant through Innenkuehlung	Lubr.esterna Ext. coolant Ausseinkuehlung	B	CHIAVI NON INCLUSE Keys not included Schluesssel nicht einbegriffen	
DW01190140	MTSK-40	1:1	6000	70Nm	X		X	54	CHUB46	OKU0650004 •
DW01190240	MTSK-40	1:1	6000	70Nm	X	P=70bar	X	65	CHUB46	OKU0650004 •

- Chiave inclusa
- Key included
- Schluesssel inbegriffen

NEW
NEW

HYUNDAI-KIA (WIA)

SKT200TTM/TTMS/TTSY (LM2000TTM/TTMS/TTSY)
 SKT250TTM/TTMS/TTSY (LM2500TTM/TTMS/TTSY) - SKT250MS - SKT300MS (L300MSA)

MODULO MOTORIZZATO ASSIALE MTSK H=100mm

Axial MTSK driven tool H=100mm

Axial MTSK angetriebenes Werkzeug H=100mm

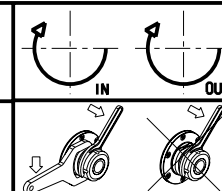

M.T. srl

Via Casino Albini 480
 Tel. 0541/956034-957884
 Fax 0541/956341
 47842 S. GIOVANNI IN M. (RN)
 e-mail: mtma@mtmarchetti.com
 http://www.mtmarchetti.com

PRODUZIONE MODULI ROTANTI



PAGINA KIA150-3-21-K

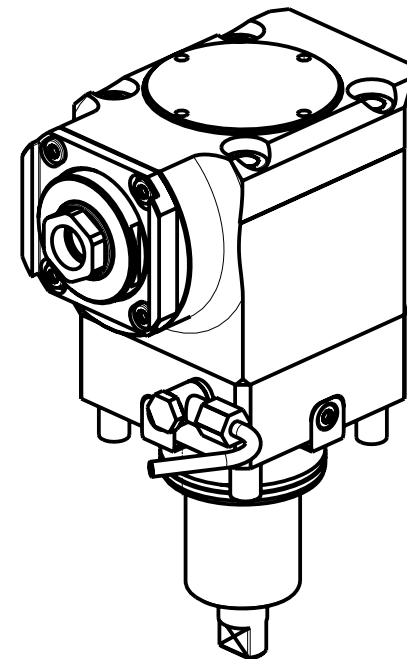
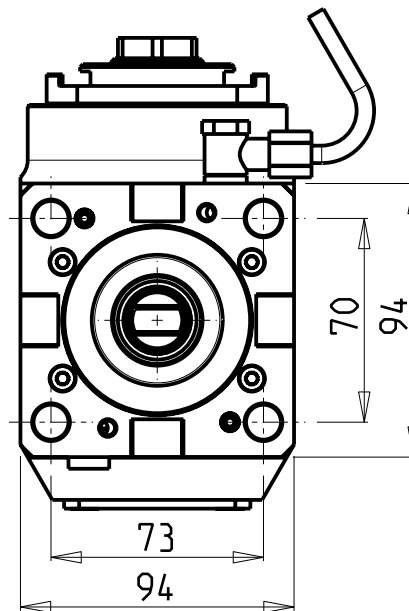
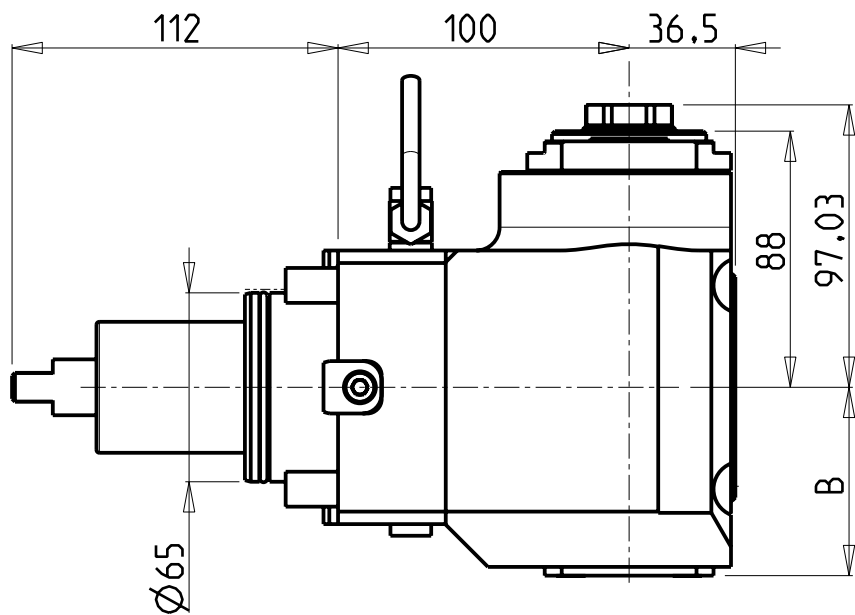

Cod. MT	Mandrino Spindle Spindel	I	RPM	Coppia Max Max Torque Max Drehmoment	Reversibile lato mandrino/contromandrino Reversible sub/main spindle side Umkehrbare Spindel-seite/ Gegenspindel-seite	Lubrificazione int. Coolant through Innenkuehlung	Lubrificazione est. Ext. coolant Aussenkuehlung	B	CHIAVI NON INCLUSE Keys not included Schlüssel nicht einbegriffen
DW00710125	ER A 25	1:2	12000	30Nm	X		X	64.7	OKU0650004 ■ CHUB27
DW00710225	ER A 25	1:2	12000	30Nm	X	P=70bar	X	73.2	OKU0650004 ■ CHUB27

NEW
NEW

- Chiave inclusa
- Key included
- Schlüssel inbegriffen

HYUNDAI-KIA (WIA)

SKT200TTM/TTMS/TTSY (LM2000TTM/TTMS/TTSY)
SKT250TTM/TTMS/TTSY (LM2500TTM/TTMS/TTSY) - SKT250MS - SKT300MS (L300MSA)

MODULO MOTORIZZATO ASSIALE MOLTIPLICATO I=1:2

Axial geared-up I=1:2 driven tool

Axial angetriebenes Werkzeug uebersetzt I=1:2

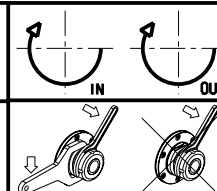

M.T. srl

Via Casino Albini 480
Tel. 0541/956034-957884
Fax 0541/956341

47842 S. GIOVANNI IN M. (RN)
e-mail: mtma@mtmarchetti.com
http://www.mtmarchetti.com

PRODUZIONE MODULI ROTANTI



PAGINA KIA200-3-20

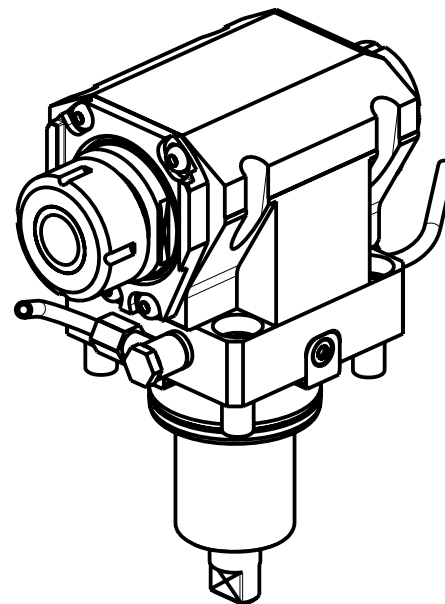
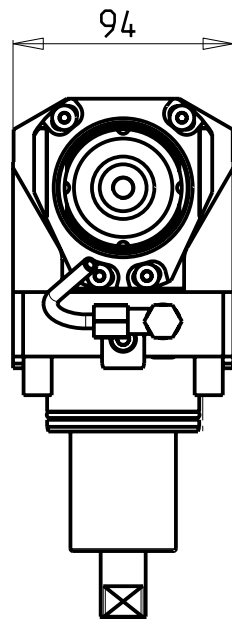
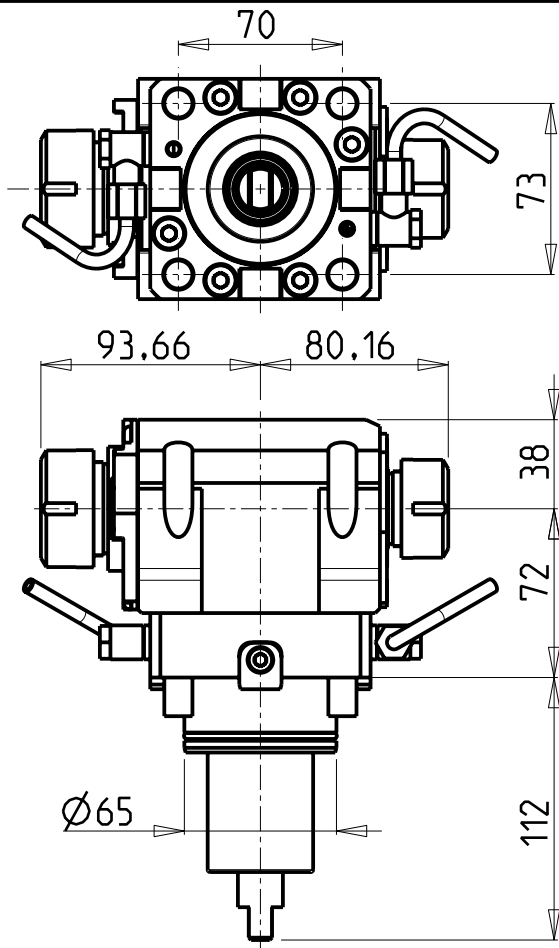

ATTENZIONE - ATTENTION - ACHTUNG

- Per lo smontaggio degli utensili utilizzare sempre la chiave di contrasto come indicato nel manuale d'uso.
- For disassembly of the tools use always the contrast key as mentioned in the user instructions.
- Fuer das Abmontieren der Werkzeuge immer den Gegenschlüssel benutzen wie in der Bedienungsanleitung erwahnt.

Cod. MT	Mandrino Spindle Spindel	I	RPM	Coppia Max Max Torque Max Drehmoment	Reversibile lato mandrino/contromandrino Reversible sub/main spindle side Umkehrbare Spindel-seite/ Gegenspindel-seite	Lubr.esterna Ext. coolant Aussenkuehlung	CHIAVI NON INCLUSE Keys not included Schluesssel nicht einbegriffen		
DW00720132	ER32+ER25	1:1	6000	70Nm	X	X	CHSTER32	CHSTER25	OKU0650004 • NEW

- Chiave inclusa
- Key included
- Schluesssel inbegriffen

HYUNDAI-KIA (WIA)
SKT250MS - SKT300MS (L300MSA)

MODULO MOTORIZZATO ASSIALE BISPORGENTE H=72mm
Axial opposite face driven tool H=72mm
Axial angetriebenes Werkzeug halb vorspringend H=72mm

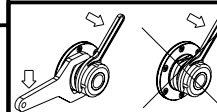

M.T. srl

Via Casino Albini 480
Tel. 0541/956034-957884
Fax 0541/956341
47842 S. GIOVANNI IN M. (RN)
e-mail: mtma@mtmarchetti.com
http://www.mtmarchetti.com

PRODUZIONE MODULI ROTANTI



PAGINA KIA240-3-10

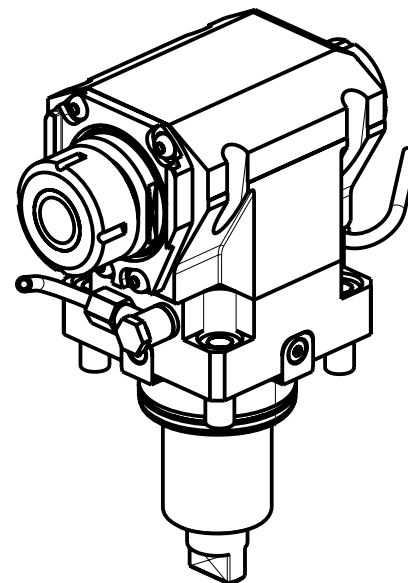
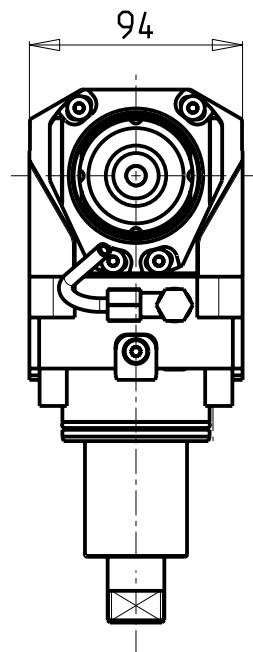
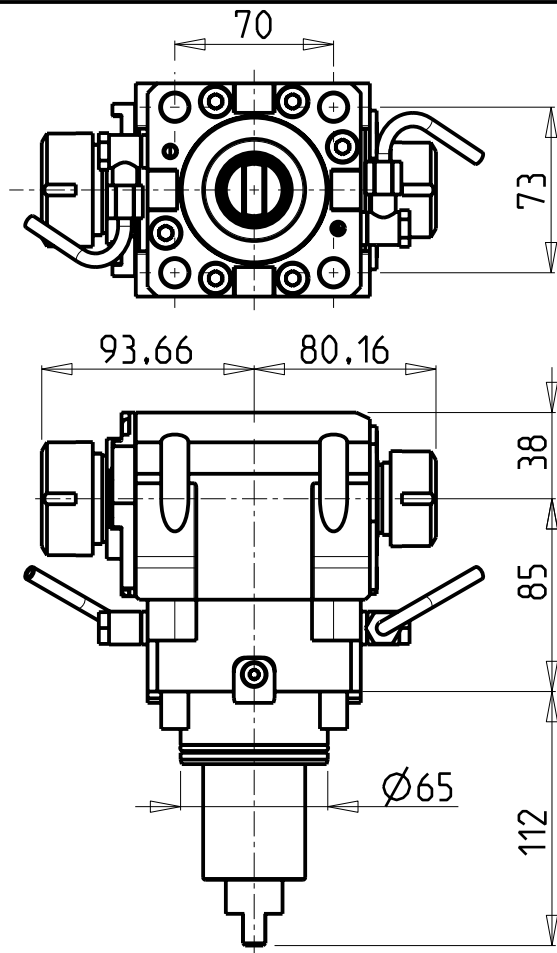

ATTENZIONE - ATTENTION - ACHTUNG

- Per lo smontaggio degli utensili utilizzare sempre la chiave di contrasto come indicato nel manuale d'uso.
- For disassembly of the tools use always the contrast key as mentioned in the user instructions.
- Fuer das Abmontieren der Werkzeuge immer den Gegenschlüssel benutzen wie in der Bedienungsanleitung erwäehnt.

Cod. MT	Mandrino Spindle Spindel	I	RPM	Coppia Max Max Torque Max Drehmoment	Reversibile lato mandrino/contromandrino Reversible sub/main spindle side Umkehrbare Spindelseite/ Gegenspindelseite	Lubr.esterna Ext. coolant Aussenkuehlung	CHIAVI NON INCLUSE Keys not included Schluessel nicht einbegriffen			
DW01150132	ER32+ER25	1:1	6000	70Nm	X	X	CHSTER32	CHSTER25	OKU0650004	NEW

- Chiave inclusa
- Key included
- Schluessel inbegriffen

HYUNDAI-KIA (WIA)

SKT200TTM/TTMS/TTSY (LM2000TTM/TTMS/TTSY)
SKT250TTM/TTMS/TTSY (LM2500TTM/TTMS/TTSY) - SKT250MS - SKT300MS (L300MSA)

MODULO MOTORIZZATO ASSIALE BISPORGENTE H=85mm

Axial opposite face driven tool H=85mm

Axial angetriebenes Werkzeug halb vorspringend H=85mm

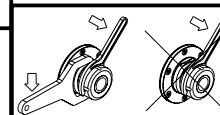

M.T. srl

Via Casino Albini 480
Tel. 0541/956034-957884
Fax 0541/956341
47842 S. GIOVANNI IN M. (RN)
e-mail: mtma@mtmarchetti.com
http://www.mtmarchetti.com

PRODUZIONE MODULI ROTANTI



PAGINA KIA240-3-15

ATTENZIONE - ATTENTION - ACHTUNG

- Per lo smontaggio degli utensili utilizzare sempre la chiave di contrasto come indicato nel manuale d'uso.
- For disassembly of the tools use always the contrast key as mentioned in the user instructions.
- Fuer das Abmontieren der Werkzeuge immer den Gegenschlüssel benutzen wie in der Bedienungsanleitung erwäehnt.

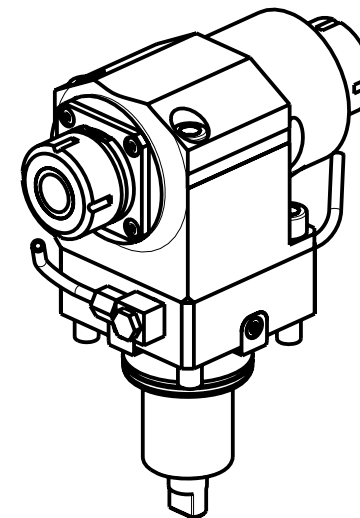
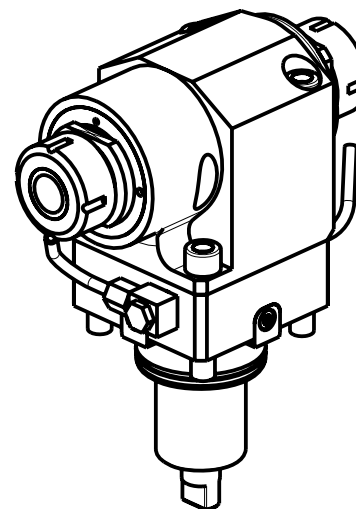
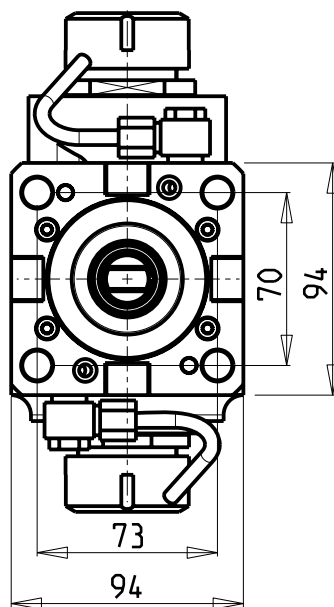
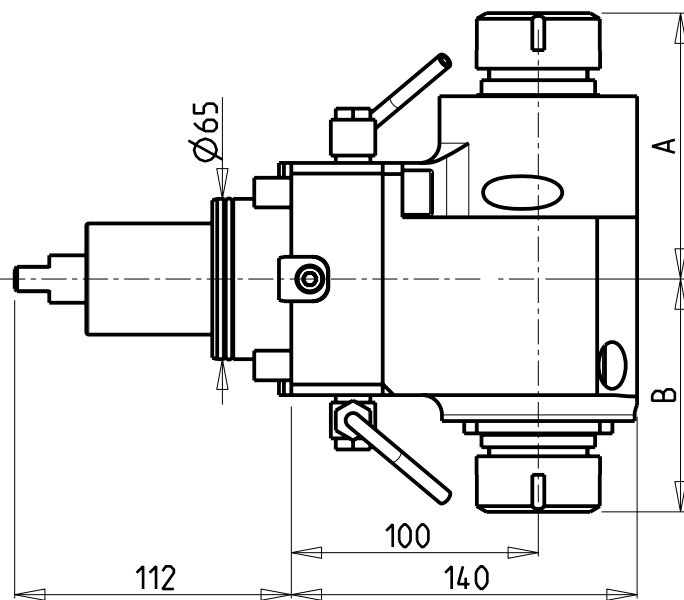

Cod. MT	Mandrino Spindle Spindel	I	RPM	Coppia Max Max Torque Max Drehmoment	Reversibile lato mandrino/contromandrino Reversible sub/main spindle side Umkehrbare Spindel-seite/ Gegenspindel-seite	Lubrificazione est. Ext. coolant Aussenkuehlung	A	B	CHIAVI NON INCLUSE Keys not included Schlüssel nicht einbegriffen		
									CHSTER32	CHUB46	CHUB46
DW 00070232	ER32+ER32	1:1	6000	70Nm	X	X	107.66	94.26	CHSTER32	CHUB46	NEW
DW 00073225	ERA25+ERA32	1:1	6000	70Nm	X	X	106.03	81.13	CHUB27	CHUB32	CHUB46 NEW

HYUNDAI-KIA (WIA)

SKT200TTM/TTMS/TTSY (LM2000TTM/TTMS/TTSY)
SKT250TTM/TTMS/TTSY (LM2500TTM/TTMS/TTSY) - SKT250MS - SKT300MS (L300MSA)

MODULO MOTORIZZATO ASSIALE BISPORGENTE H=100mm

Axial opposite face twin driven tool H=100mm

Axial angetriebenes Werkzeug halb vorspringend H=100mm

M.T. srl

Via Casino Albini 480
Tel. 0541/956034-957884
Fax 0541/956341
47842 S. GIOVANNI IN M. (RN)
e-mail: mtma@mtmarchetti.com
http://www.mtmarchetti.com

PRODUZIONE MODULI ROTANTI



PAGINA KIA240-3-20

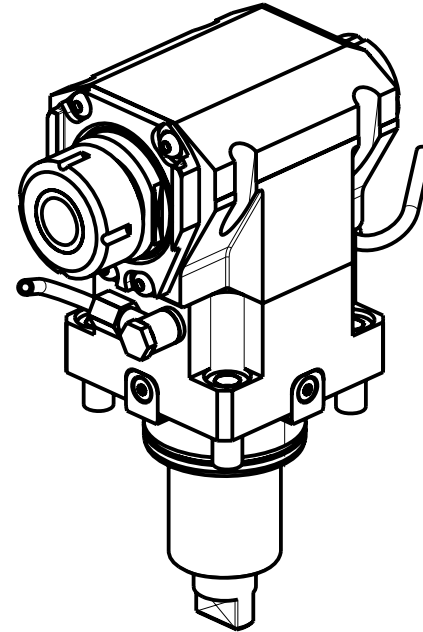
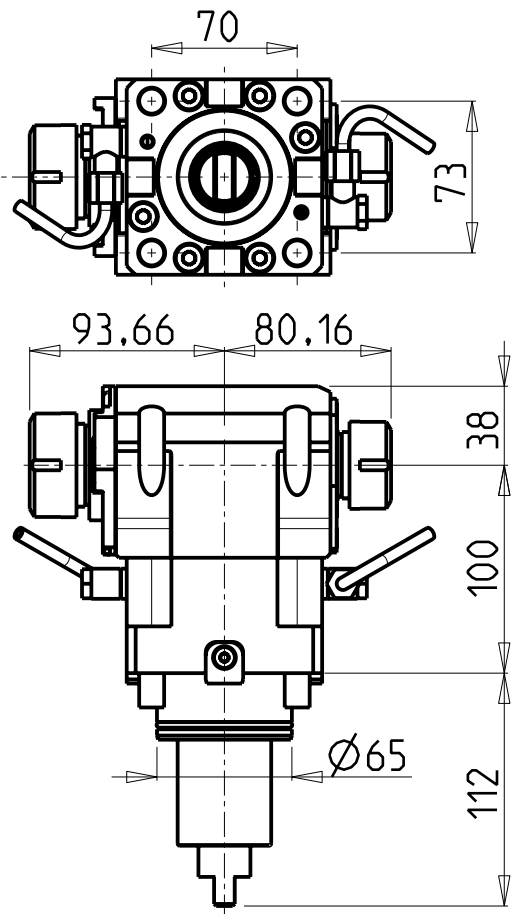

ATTENZIONE - ATTENTION - ACHTUNG

- Per lo smontaggio degli utensili utilizzare sempre la chiave di contrasto come indicato nel manuale d'uso.
- For disassembly of the tools use always the contrast key as mentioned in the user instructions.
- Fuer das Abmontieren der Werkzeuge immer den Gegenschlüssel benutzen wie in der Bedienungsanleitung erwäehnt.

Cod. MT	Mandrino Spindle Spindel	I	RPM	Coppia Max Max Torque Max Drehmoment	Reversibile lato mandrino/contromandrino Reversible sub/main spindle side Umkehrbare Spindel-seite/ Gegenspindel-seite	Lubr.esterna Ext. coolant Aussenkuehlung	CHIAVI NON INCLUSE Keys not included Schluessel nicht einbegriffen			
DW01160132	ER32+ER25	1:1	6000	70Nm	X	X	CHSTER32	CHSTER25	OKU0650004	NEW

- Chiave inclusa
- Key included
- Schluessel inbegriffen

HYUNDAI-KIA (WIA)
 SKT200TTM/TTMS/TTSY (LM2000TTM/TTMS/TTSY)
 SKT250TTM/TTMS/TTSY (LM2500TTM/TTMS/TTSY) - SKT250MS - SKT300MS (L300MSA)
 MODULO MOTORIZZATO ASSIALE BISPORGENTE H=100mm
 Axial opposite face driven tool H=100mm
 Axial angetriebenes Werkzeug halb vorspringend H=100mm

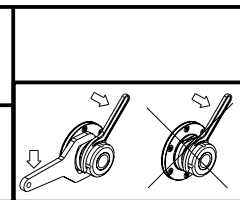

M.T. srl
 Via Casino Albini 480
 Tel. 0541/956034-957884
 Fax 0541/956341
 47842 S. GIOVANNI IN M. (RN)
 e-mail: mtma@mtmarchetti.com
 http://www.mtmarchetti.com

PRODUZIONE MODULI ROTANTI

PAGINA KIA240-3-21

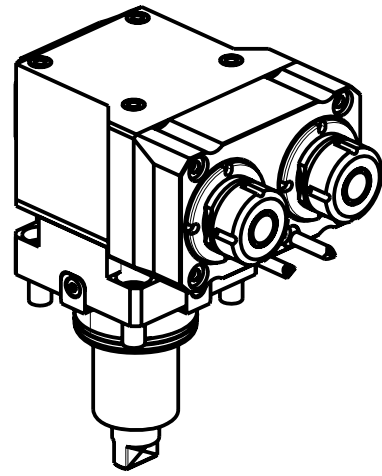
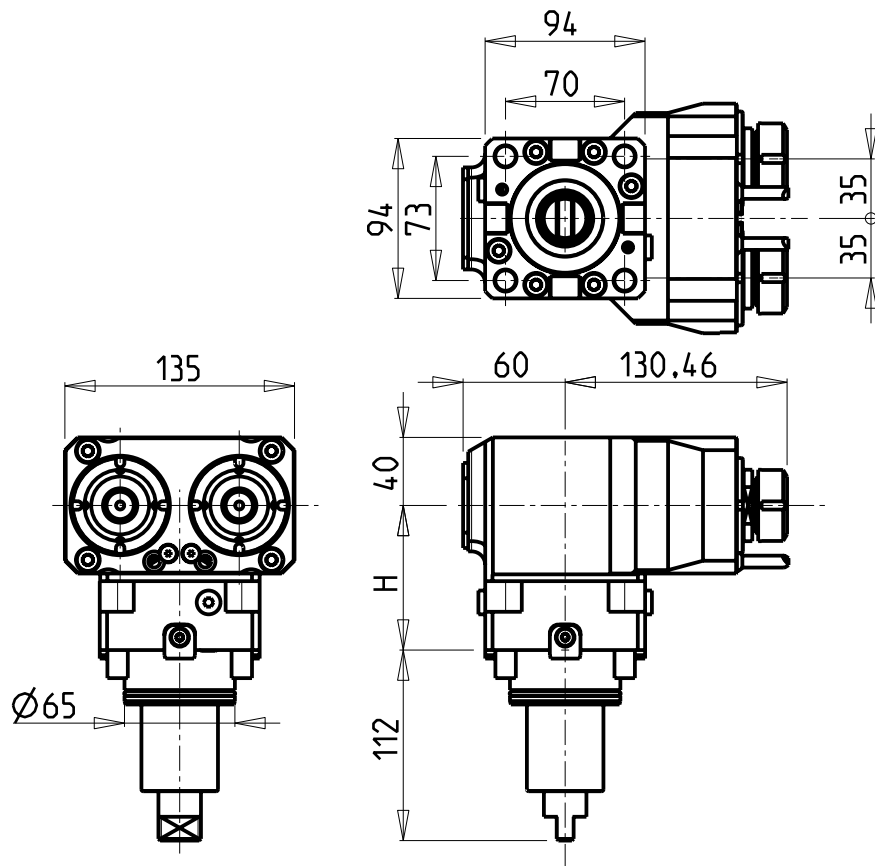

ATTENZIONE - ATTENTION - ACHTUNG

- Per lo smontaggio degli utensili utilizzare sempre la chiave di contrasto come indicato nel manuale d'uso.
- For disassembly of the tools use always the contrast key as mentioned in the user instructions.
- Fuer das Abmontieren der Werkzeuge immer den Gegenschlüssel benutzen wie in der Bedienungsanleitung erwaeht.

Cod. MT	Mandrino Spindle Spindel	I	RPM	Coppia Max Max Torque Max Drehmoment	Reversibile lato mandrino/contromandrino Reversible sub/main spindle side Umkehrbare Spindelseite/ Gegenspindelseite	Lubrificazione est. Ext. coolant Aussenkuehlung	H	CHIAVI NON INCLUSE Keys not included Schluessel nicht einbegriffen		
DW 01120225	ER25	1:1	6000	40Nm	X	X	72	CHUB36	CHSTER25	NEW
DW 01220225	ER25	1:1	6000	40Nm	X	X	85	CHUB36	CHSTER25	NEW
DW 01230225	ER25	1:1	6000	40Nm	X	X	100	CHUB36	CHSTER25	NEW

HYUNDAI-KIA (WIA)
 SKT200TTM/TTMS/TTSY (LM2000TTM/TTMS/TTSY)
 SKT250TTM/TTMS/TTSY (LM2500TTM/TTMS/TTSY) - SKT250MS - SKT300MS (L300MSA)

MODULO MOTORIZZATO ASSIALE 2 USCITE IN Y
 Axial single side twin head driven tool in Y
 Axial angetriebenes Werkzeug 2 Ausgaenge in Y

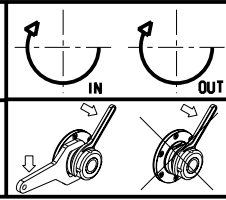

M.T. srl
 Via Casino Albini 480
 Tel. 0541/956034-957884
 Fax 0541/956341
 47842 S. GIOVANNI IN M. (RN)
 e-mail: mtma@mtmarchetti.com
 http://www.mtmarchetti.com

PRODUZIONE MODULI ROTANTI

PAGINA KIA260-3-10

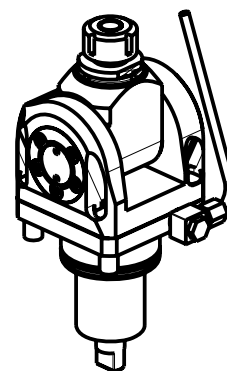
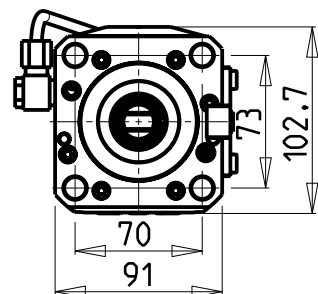
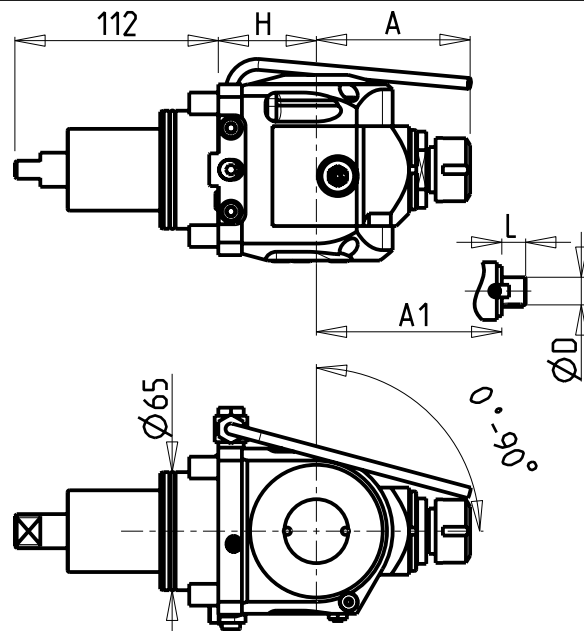

ATTENZIONE - ATTENTION - ACHTUNG

- VERIFICARE LE MISURE DI INGOMBRO PER POSSIBILE INTERFERENZA SU ALCUNI MODELLI DI MACCHINE
- Please check the overall sizes for possible interferences on some machine models
- Bitte überprüfen sie das ausmass um mögliche interferenzen auf einigen maschinen modellen zu vermeiden

ATTENZIONE: In posizione a 90° il motorizzato non arriva in centro mandrino

WARNING: At 90° tool doesn't reach centre of spindle axis.

ACHTUNG: Bei 90° erreicht das Werkzeug nicht die Mitte der Spindel-Achse.

#	Cod. MT	Mandrino Spindle Spindel	I	RPM	Coppia Max Max Torque Max Drehmoment	Reversibile lato mandrino/contromandrino Reversible sub/main spindle side Umkehrbare Spindel-seite/ Gegenspindel-seite	Lubr.esterna Ext. coolant Aussenkuehlung	H	A	A1	D	L	CHIAVI INCLUSE Keys included Schlüssel inbegriffen		
													CHSTER20	CHUB36	CHESL10
#	0370020	ER20	1:1	6000	40Nm	X	X	54	84.66	-	-	-	CHSTER20	CHUB36	CHESL10
#	0370120	ER20	1:1	6000	40Nm	X	X	100	84.66	-	-	-	CHSTER20	CHUB36	CHESL10
#	0370025	ER25	1:1	6000	40Nm	X	X	54	85.66	-	-	-	CHSTER25	CHUB36	CHESL10
#	0370125	ER25	1:1	6000	40Nm	X	X	100	85.66	-	-	-	CHSTER25	CHUB36	CHESL10
#	0371617	Ø16x17	1:1	6000	40Nm	X	X	54	-	65	16	17	CH_VTCROCE_M08	CHUB36	CHESL10
#	0372617	Ø16x17	1:1	6000	40Nm	X	X	100	-	65	16	17	CH_VTCROCE_M08	CHUB36	CHESL10
#	0372219	Ø22x19	1:1	6000	40Nm	X	X	54	-	66	22	19	CH_VTCROCE_M10	CHUB36	CHESL10
#	0373219	Ø22x19	1:1	6000	40Nm	X	X	100	-	66	22	19	CH_VTCROCE_M10	CHUB36	CHESL10
#	0371905	Ø3/4"x3/4"	1:1	6000	40Nm	X	X	54	-	65	3/4"	3/4"	CH_VTCROCE_M08	CHUB36	CHESL10
#	0372905	Ø3/4"x3/4"	1:1	6000	40Nm	X	X	100	-	65	3/4"	3/4"	CH_VTCROCE_M08	CHUB36	CHESL10

HYUNDAI-KIA (WIA)

SKT200TTM/TTMS/TTSY (LM2000TTM/TTMS/TTSY)
SKT250TTM/TTMS/TTSY (LM2500TTM/TTMS/TTSY) - SKT250MS - SKT300MS (L300MSA)

MODULO MOTORIZZATO ORIENTABILE 0-90°

0-90° adjustable angle driven tool

Angetriebenes Werkzeug schwenkbar 0-90°

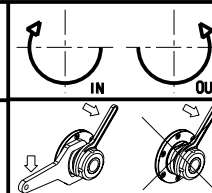

M.T. srl

Via Casino Albini 480
Tel. 0541/956034-957884

Fax 0541/956341

47842 S. GIOVANNI IN M. (RN)
e-mail: mtma@mtmarchetti.com
http://www.mtmarchetti.com

PRODUZIONE MODULI ROTANTI



PAGINA KIA330-3-00

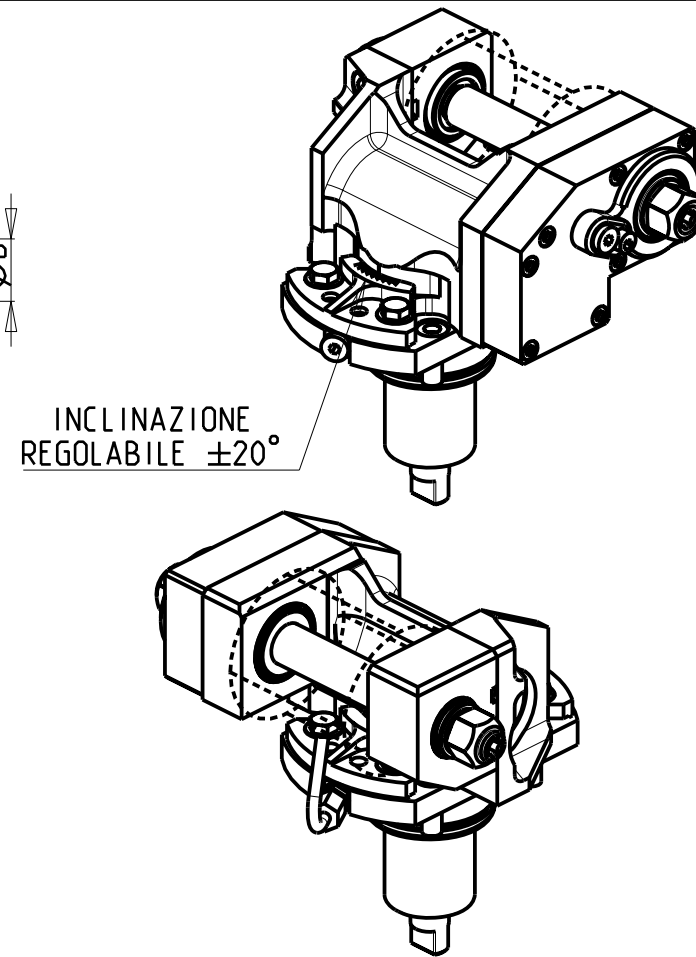
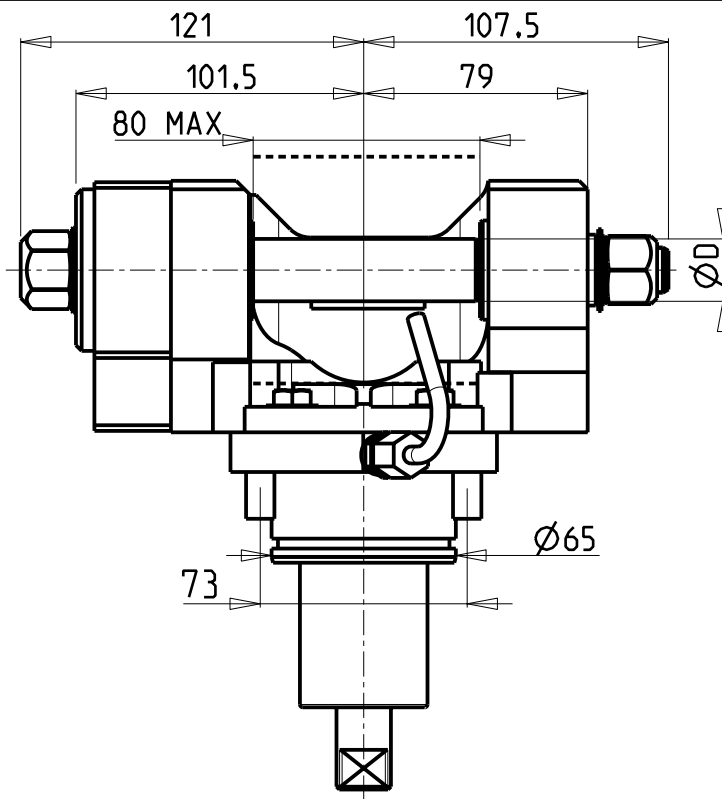
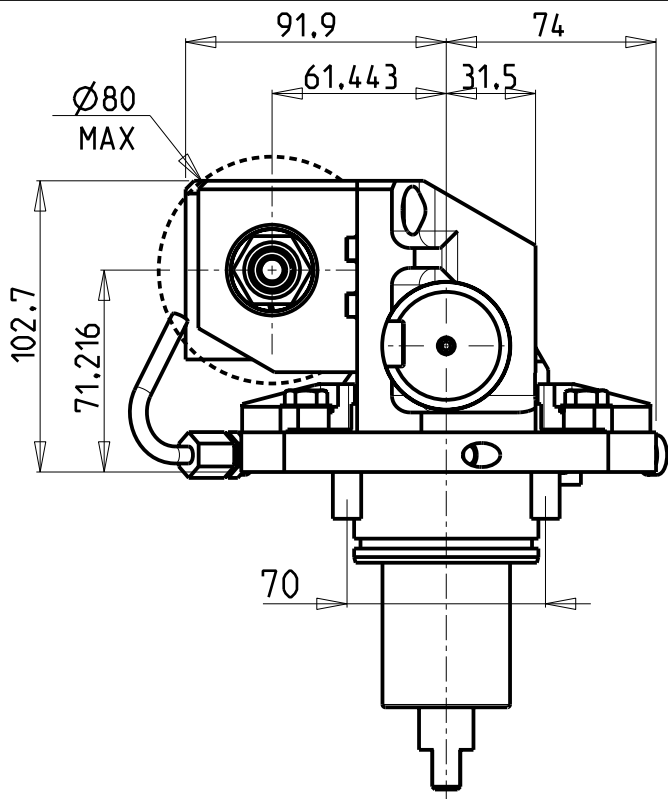

DOTAZIONI - SUPPLIED WITH - AUSSTATTUNG

- mm / inch**
- N°1 ALBERO + DISTANZIALI
 - N°1 SHAFT + SPACER
 - N°1 DORN + ABSTANDSSTUECK

PER ALBERI E DISTANZIALI VEDI PAG. TBL250-1-00
 FOR SHAFT END SPACER SEE PAGE TBL250-1-00
 FUER DORN UND ABSTANDSSTUECK SEITE TBL250-1-00

Cod. MT	I	RPM	Coppia Max Max Torque Max Drehmoment	Reversibile lato mandrino/contromandrino Reversible sub/main spindle side Umkehrbare Spindel-seite/ Gegenspindel-seite	Lubrificazione est. Ext. coolant Aussenkuehlung	D (mm)	D (Inch)	CHIAVI INCLUSE Keys included Schlüssel inbegriffen		
								CHUB24	CHUB13	CHESL08
0321100	1:1	6000	60Nm	X	X	16-22-27-32	3/4"-1"-1 1/4"	CHUB24	CHUB13	CHESL08
0322100	2:1	3000	80Nm	X	X	16-22-27-32	3/4"-1"-1 1/4"	CHUB24	CHUB13	CHESL08

HYUNDAI-KIA (WIA)

SKT200TTM/TTMS/TTSY (LM2000TTM/TTMS/TTSY)
 SKT250TTM/TTMS/TTSY (LM2500TTM/TTMS/TTSY) - SKT250MS - SKT300MS (L300MSA)

MODULO MOTORIZZATO PORTACREATORE

Driven gear hobber

Angetriebenes Zahnradwaelzfraes-Werkzeug

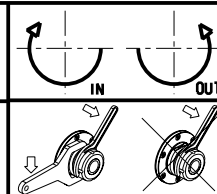

M.T. srl

Via Casino Albini 480
 Tel. 0541/956034-957884
 Fax 0541/956341
 47842 S. GIOVANNI IN M. (RN)
 e-mail: mtma@mtmarchetti.com
 http://www.mtmarchetti.com

PRODUZIONE MODULI ROTANTI



PAGINA KIA340-3-00

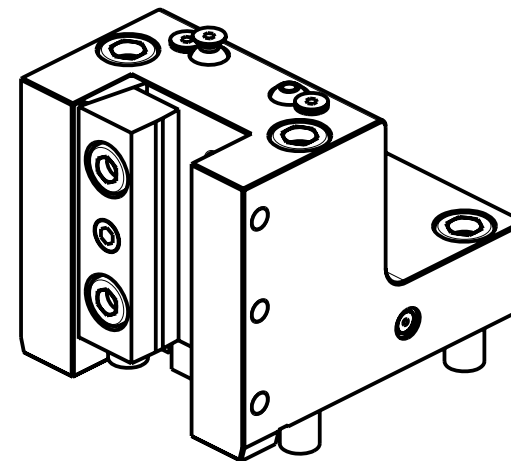
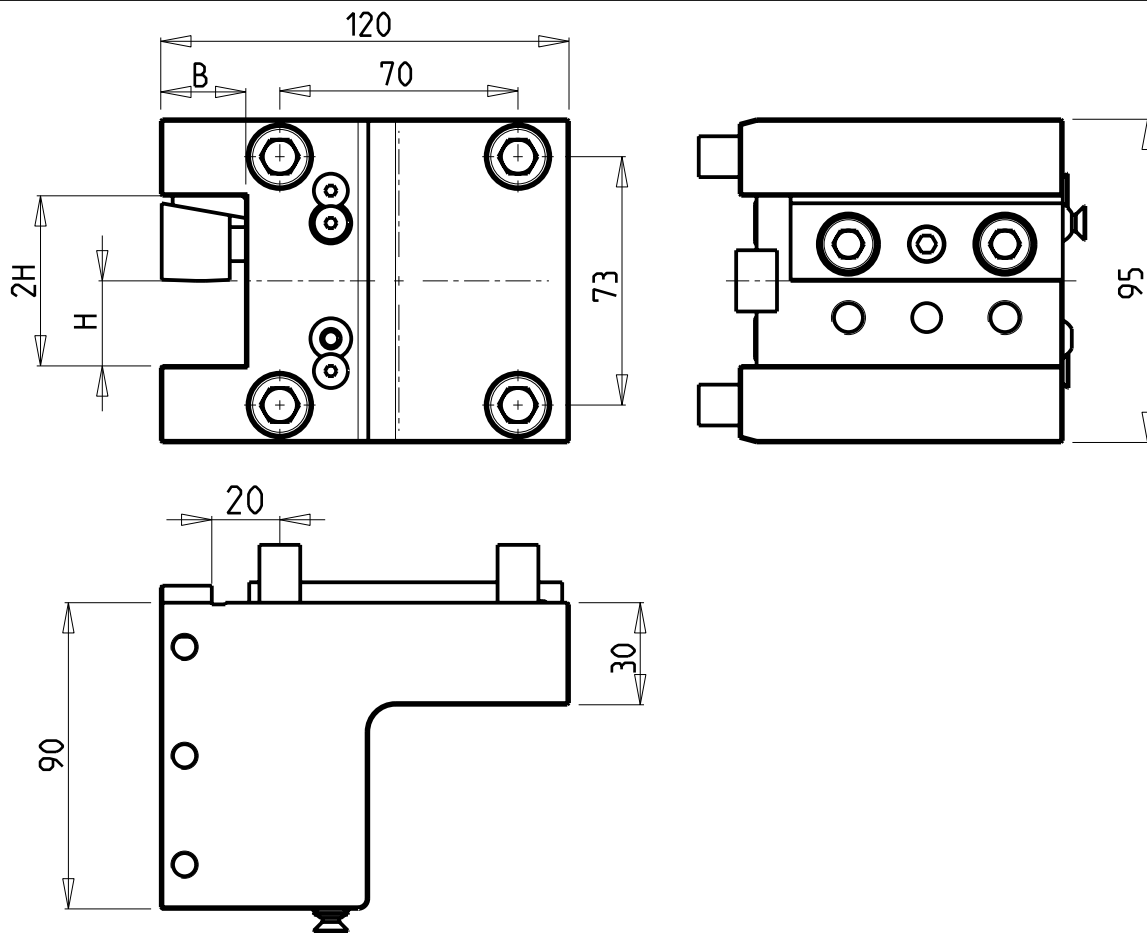

Cod. MT	N°Utensili N°Tools N°Werkzeuge	Reversibile lato mandrino/contromandrino Reversible sub/main spindle side Umkehrbare Spindelseite/ Gegenspindelseite	Misure Dimensions Masse	B	H
DW00482500	1	X	mm	25	25

HYUNDAI-KIA (WIA)
 SKT200TTM/TTMS/TTSY (LM2000TTM/TTMS/TTSY)
 SKT250TTM/TTMS/TTSY (LM2500TTM/TTMS/TTSY) - SKT250MS - SKT300MS (L300MSA)
 PORTAUTENSILE RADIALE SINGOLO
 Radial single static tool
 Radial Single-Werkzeughalter

M.T. srl
 Via Casino Albini 480
 Tel. 0541/956034-957884
 Fax 0541/956341
 47842 S. GIOVANNI IN M. (RN)
 e-mail: mtma@mtmarchetti.com
 http://www.mtmarchetti.com

PRODUZIONE MODULI ROTANTI



PAGINA KIA423-3-00

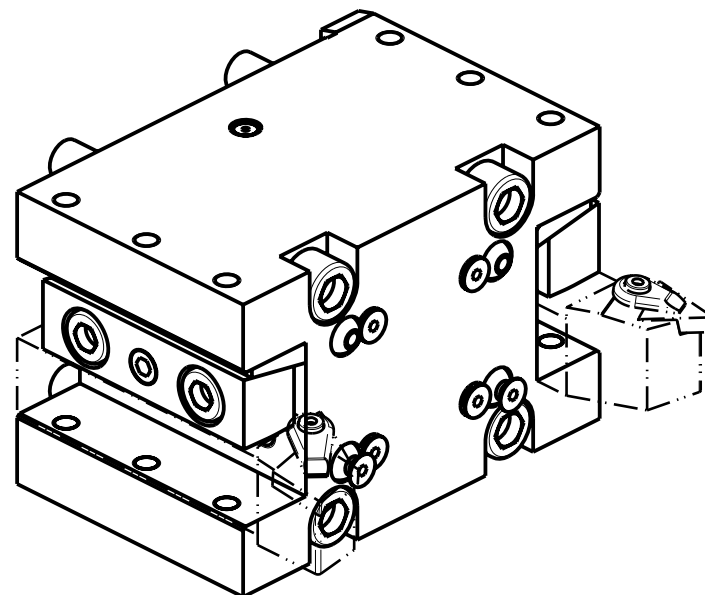
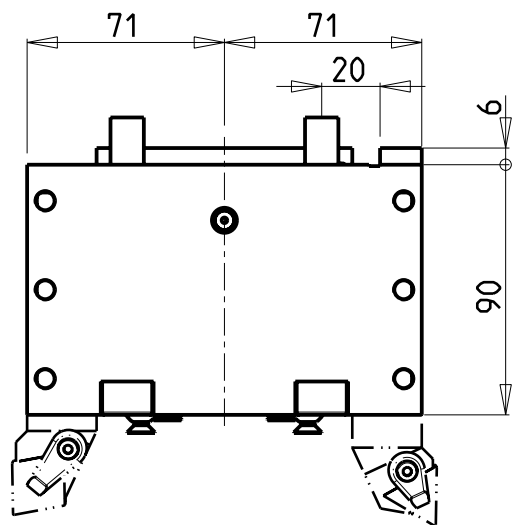
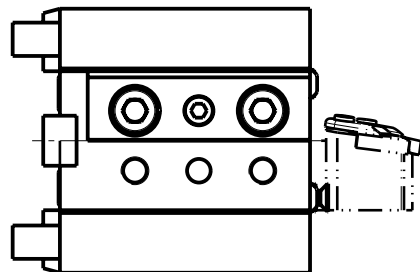
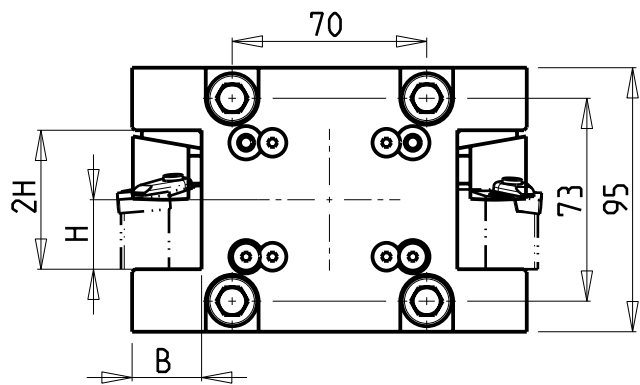

Cod. MT	N°Utensili N° Tools N° Werkzeuge	Reversibile lato mandrino/contromandrino Reversible sub/main spindle side Umkehrbare Spindel-seite/ Gegenspindel-seite	Misure Dimensions Masse	B	H
DW 00272500	2/4	X	mm	25	25
DW 00272540	2/4	X	Inch	1"	1"

HYUNDAI-KIA (WIA)

SKT200TTM/TTMS/TTSY (LM2000TTM/TTMS/TTSY)

SKT250TTM/TTMS/TTSY (LM2500TTM/TTMS/TTSY) - SKT250MS - SKT300MS (L300MSA)

PORTAUTENSILE RADIALE DOPPIO

Radial double static tool

Radial Doppel-Werkzeughalter

M.T. srl

Via Casino Albini 480

Tel. 0541/956034-957884

Fax 0541/956341

47842 S. GIOVANNI IN M. (RN)

e-mail: mtma@mtmarchetti.com

http://www.mtmarchetti.com

PRODUZIONE MODULI ROTANTI



PAGINA KIA453-3-00

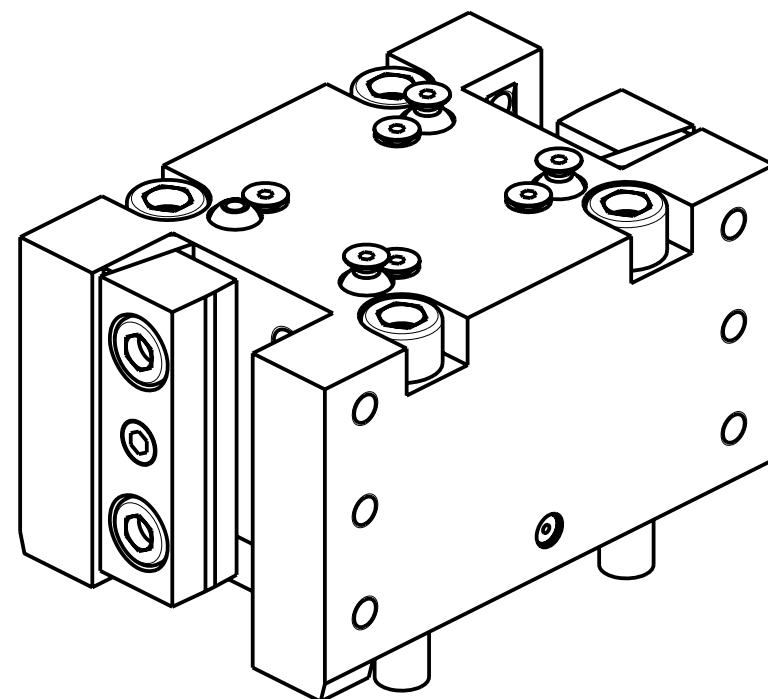
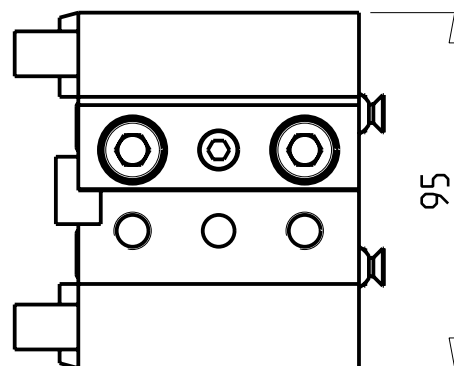
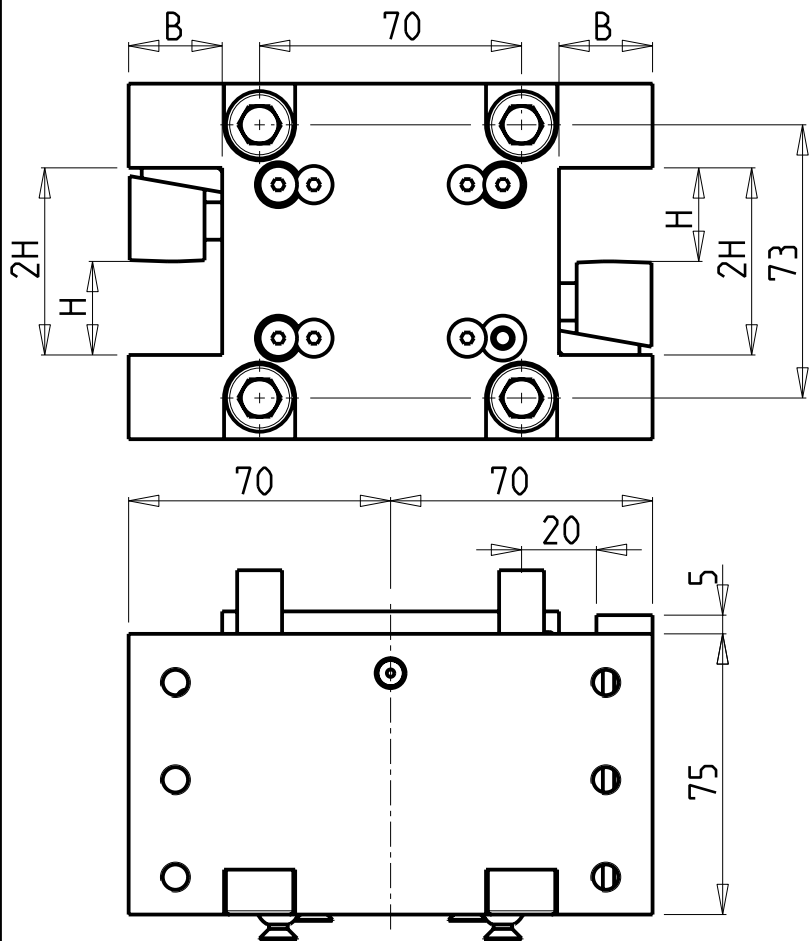

Cod. MT	N°Utensili N°Tools N°Werkzeuge	Reversibile lato mandrino/contromandrino Reversible sub/main spindle side Umkehrbare Spindelseite/ Gegenspindelseite	Misure Dimensions Masse	B	H
DW 00672500	2/4	X	mm	25	25

HYUNDAI-KIA (WIA)

SKT200TTM/TTMS/TTSY (LM2000TTM/TTMS/TTSY)

SKT250TTM/TTMS/TTSY (LM2500TTM/TTMS/TTSY) - SKT250MS - SKT300MS (L300MSA)

PORTAUTENSILE RADIALE DOPPIO

Radial double static tool

Radial Doppel-Werkzeughalter

M.T. srl

Via Casino Albini 480

Tel. 0541/956034-957884

Fax 0541/956341

47842 S. GIOVANNI IN M. (RN)

e-mail: mtma@mtmarchetti.com

http://www.mtmarchetti.com

PRODUZIONE MODULI ROTANTI



PAGINA KIA453-3-10

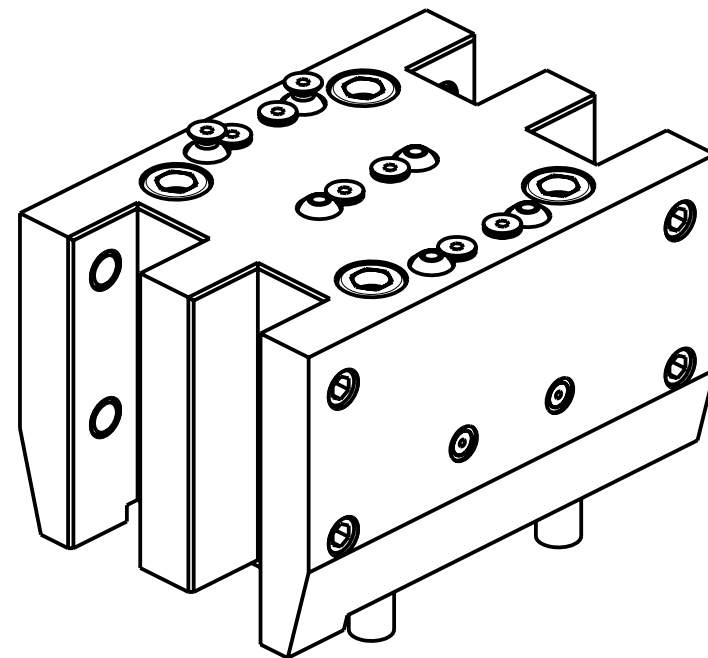
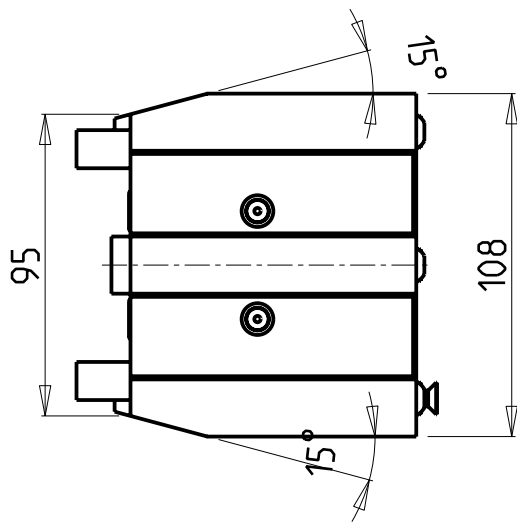
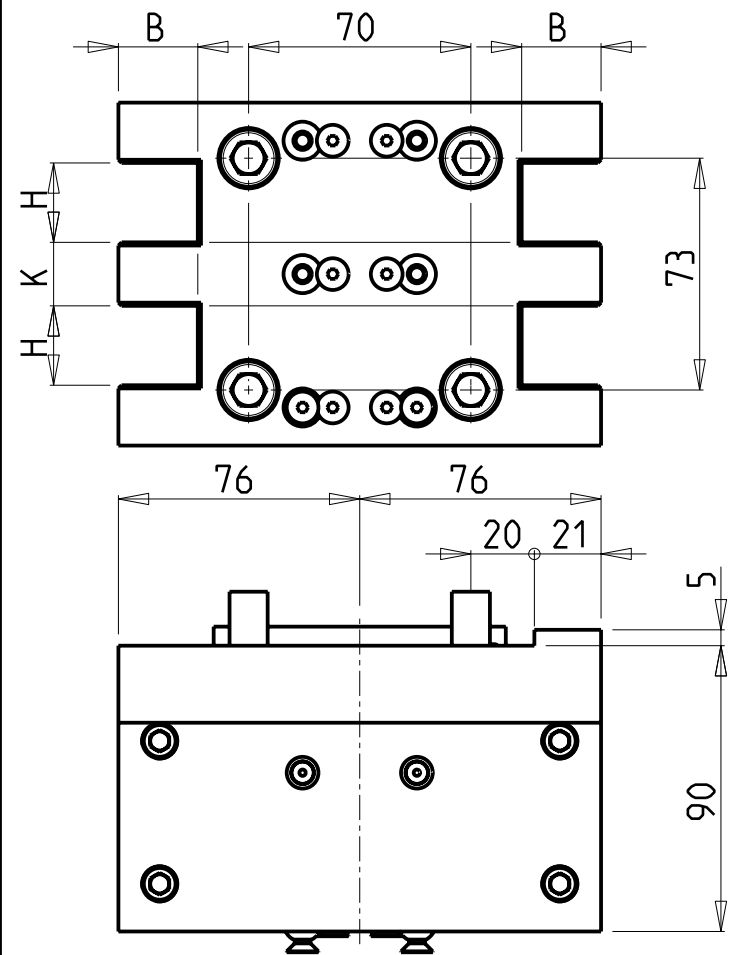

Cod. MT	N°Utensili N°Tools N°Werkzeuge	Reversibile lato mandrino/contromandrino Reversible sub/main spindle side Umkehrbare Spindel-seite/ Gegenspindel-seite	Misure Dimensions Masse	H	K	B
DW 00622500	4	X	mm	25	20	25
DW 00622540	4	X	inch	1"	3/4"	1"

HYUNDAI-KIA (WIA)

SKT200TTM/TTMS/TTSY (LM2000TTM/TTMS/TTSY)
SKT250TTM/TTMS/TTSY (LM2500TTM/TTMS/TTSY) - SKT250MS - SKT300MS (L300MSA)

PORTAUTENSILE RADIALE DOPPIO SOVRAPPOSTO

Radial double side twin static tool

Radial Doppel-Werkzeughalter ueberlagert

M.T. srl

Via Casino Albini 480
Tel. 0541/956034-957884
Fax 0541/956341
47842 S. GIOVANNI IN M. (RN)
e-mail: mtma@mtmarchetti.com
http://www.mtmarchetti.com

PRODUZIONE MODULI ROTANTI



PAGINA KIA463-3-00

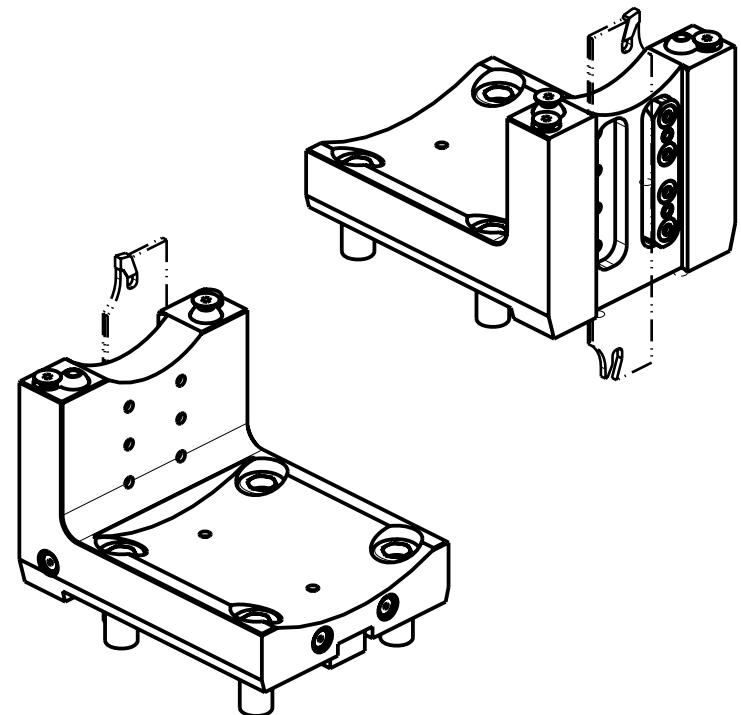
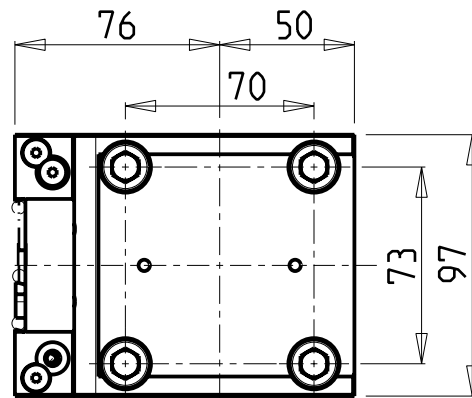
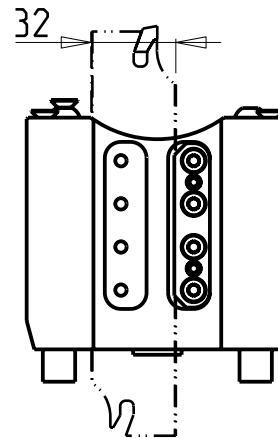
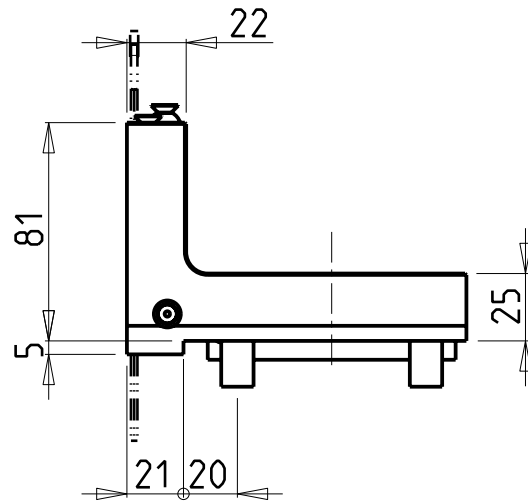
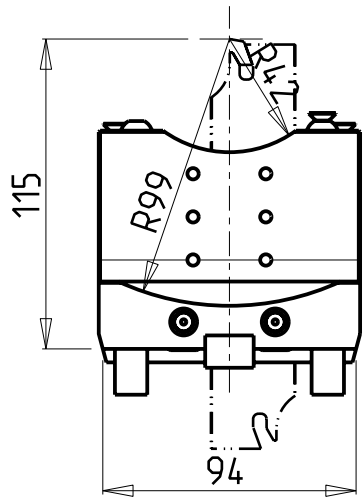

POSSIBILITA' DI LAVORO M3/M4
 OPTION OF M3/M4 WORKING
 ARBEITSMOEGlichkeit M3/M4

- DOTAZIONI - SUPPLIED WITH - AUSSTATTUNG**
- N°1 - LAMA - BLADE - KLINGE ISCAR H=32 Sp. 3/4mm (KENNAMETAL OPTIONAL)
 - N°10 - INSERTI - INSERTS - EINLAGEN
 - N°1 - CHIAVE A T PER MONTAGGIO INSERTI
 - T-WRENCH FOR INSERT SET UP
 - T-SCHLUESSEL FUER EINSATZSTUECK-MONTAGE

Cod. MT	N°Utensili N°Tools N°Werkzeuge	Reversibile lato mandrino/contromandrino Reversible sub/main spindle side Umkehrbare Spindelseite/ Gegenspindelseite	Lubr.esterna Ext. coolant Aussenkuehlung
DW 00690132	1	X	X

NEW

HYUNDAI-KIA (WIA)
 SKT200TTM/TTMS/TTSY (LM2000TTM/TTMS/TTSY)
 SKT250TTM/TTMS/TTSY (LM2500TTM/TTMS/TTSY) - SKT250MS - SKT300MS (L300MSA)
 PORTAUTENSILE RADIALE PER LAMA
 Radial blade holder
 Radial Abstechhalter



M.T. srl
 Via Casino Albini 480
 Tel. 0541/956034-957884
 Fax 0541/956341
 47842 S. GIOVANNI IN M. (RN)
 e-mail: mtma@mtmarchetti.com
 http://www.mtmarchetti.com

PRODUZIONE MODULI ROTANTI

PAGINA KIA510-3-00

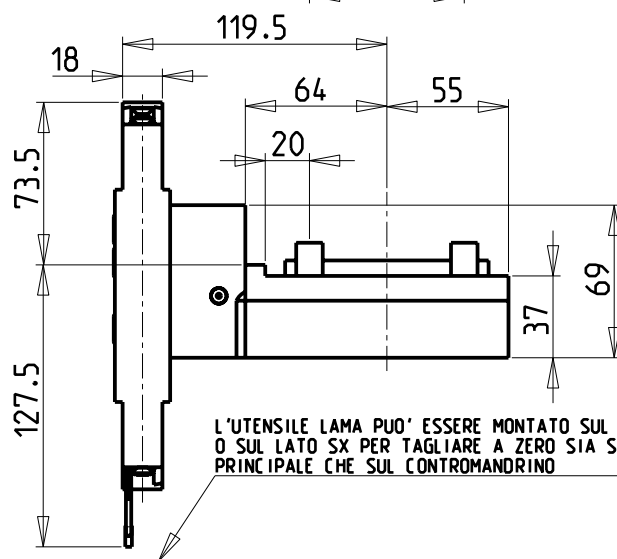
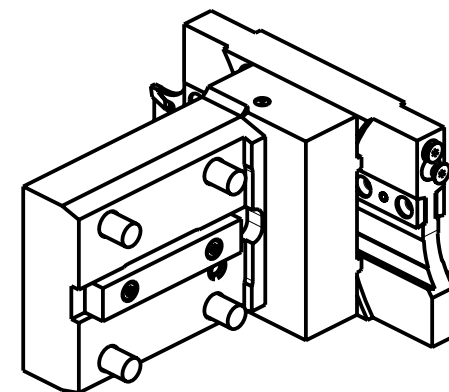
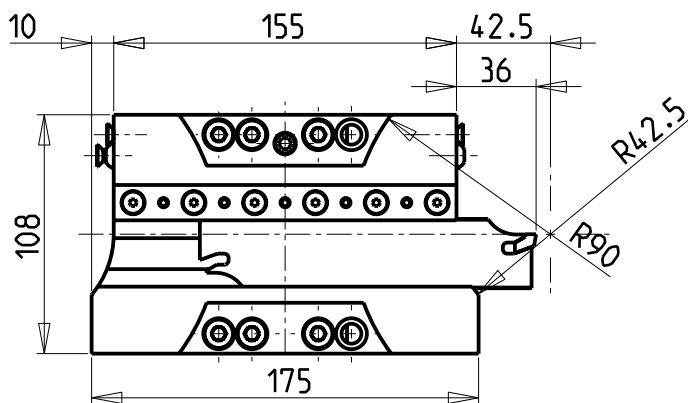
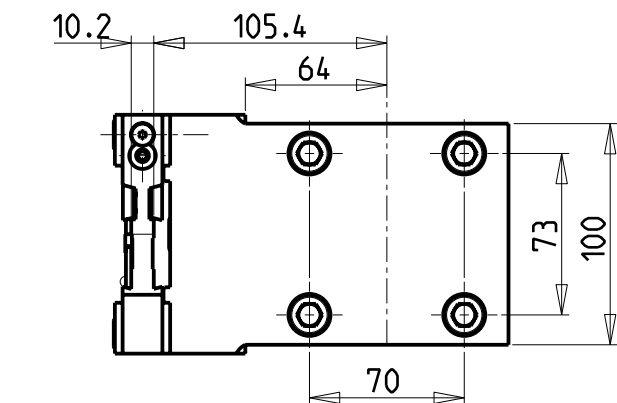

L'UTENSILE LAMA PUO' ESSERE MONTATO SUL LATO DX
O SUL LATO SX PER TAGLIARE A ZERO SIA SUL MANDRINO
PRINCIPALE CHE SUL CONTROMANDRINO

POSSIBILITA' DI LAVORO M3/M4
OPTION OF M3/M4 WORKING
ARBEITSMÖGLICHKEIT M3/M4

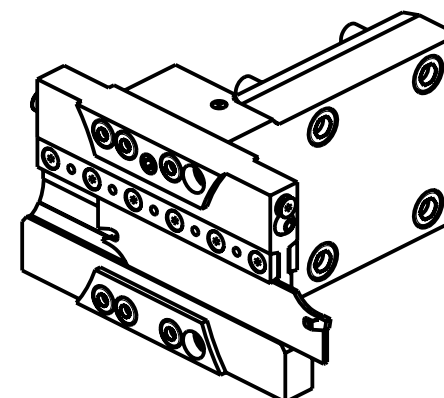

ATTENZIONE - ATTENTION - ACHTUNG

- FINO AD ESAURIMENTO SCORTE
- clearance sale
- solange vorrat

DOTAZIONI - SUPPLIED WITH - AUSSTATTUNG

- N°1 - LAMA - BLADE - KLINGE ISCAR H=32 Sp. 3/4mm (KENNAMETAL OPTIONAL)
- N°10 - INSERTI - INSERTS - EINLAGEN
- N°1 - CHIAVE A T PER MONTAGGIO INSERTI
- T-WRENCH FOR INSERT SET UP
- T-SCHLUESSEL FUER EINSATZSTUECK-MONTAGE

Cod. MT

N°Utensili
N°Tools
N°Werkzeuge

DW 00120132

1

HYUNDAI-KIA (WIA)
MOD: SKT250MS - SKT300MS (L300MSA)

PORTAUTENSILE PER LAMA DOPPIO
Radial double blade holder
Radial Doppel-Abstechhalter

M.T. srl

Via Casino Albini 480
Tel. 0541/956034-957884
Fax 0541/956341
47842 S. GIOVANNI IN M. (RN)
e-mail: mtma@mtmarchetti.com
http://www.mtmarchetti.com

PRODUZIONE MODULI ROTANTI



PAGINA KIA520-3-00

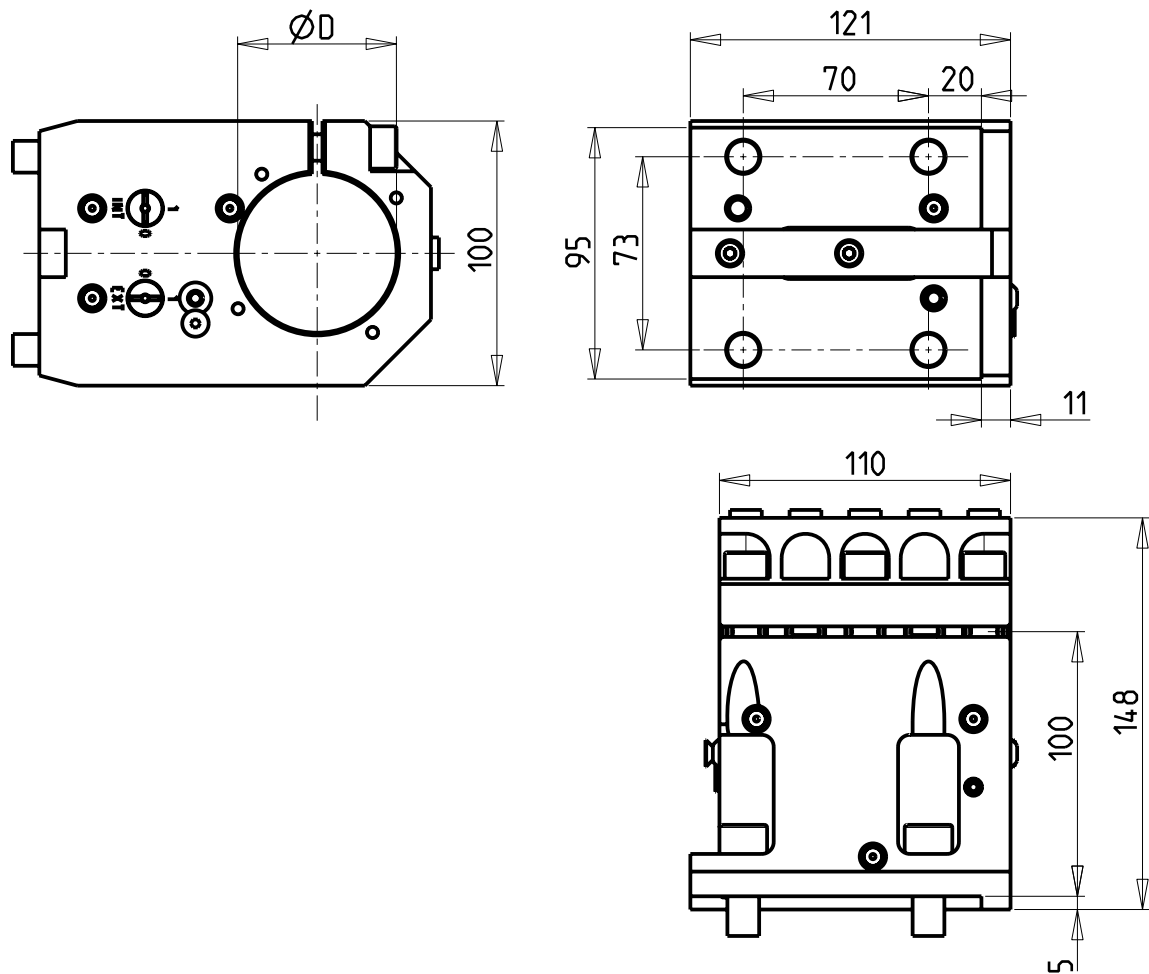

KIT ADDUZIONE INTERNA (OPZIONALE)
 KIT FOR INTERNAL COOLANT (OPTIONAL)
 KIT FUR INTERNE KUEHLMITTELZUFUHR (OPTIONAL)
 Ø60 cod. KIT1003025

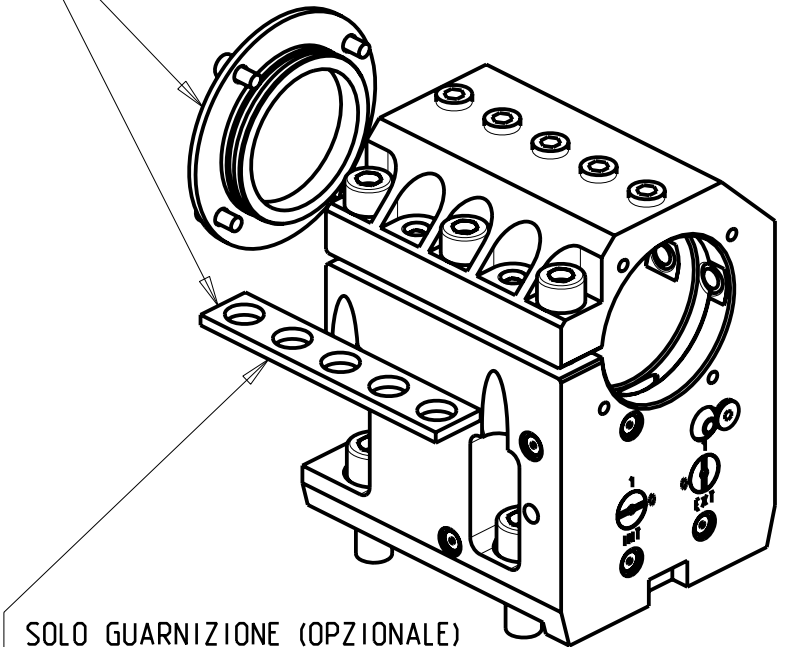

SOLO GUARNIZIONE (OPZIONALE)
 ONLY SEAL (OPTIONAL) NUR
 DICHTUNG (OPTIONAL) cod.
 0520013

PER BOCCOLE DI RIDUZIONE VEDI PAG. TBL150-1-00
 FOR REDUCING BUSHINGS SEE PAGE TBL150-1-00
 FUR REDUZIERBUCHSE SIEHE SEITE TBL150-1-00

Cod. MT	N°Utensili N°Tools N°Werkzeuge	Reversibile lato mandrino/contromandrino Reversible sub/main spindle side Umkehrbare Spindel-seite/ Gegenspindel-seite	Lubrificazione int. opzionale Coolant through optional Innenkuehlung Optional	Lubrificazione est. Ext. coolant Aussenkuehlung	Misure Dimensions Masse	D
DW00746000	1	X	X	X	mm	60

NEW

HYUNDAI-KIA (WIA)

SKT200TTM/TTMS/TTSY (LM2000TTM/TTMS/TTSY)
 SKT250TTM/TTMS/TTSY (LM2500TTM/TTMS/TTSY) - SKT250MS - SKT300MS (L300MSA)

PORTAUTENSILE ASSIALE PER BARENO Ø60mm H=100mm

Axial single boring bar holder Ø60mm H=100mm

Axial Bohrhälter Ø60mm H=100mm

M.T. srl

Via Casino Albini 480
 Tel. 0541/956034-957884
 Fax 0541/956341
 47842 S. GIOVANNI IN M. (RN)
 e-mail: mtma@mtmarchetti.com
 http://www.mtmarchetti.com

PRODUZIONE MODULI ROTANTI



PAGINA KIA590-3-20

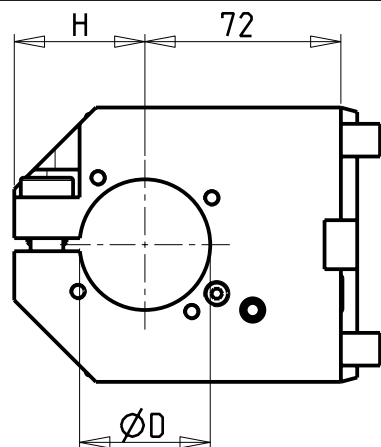
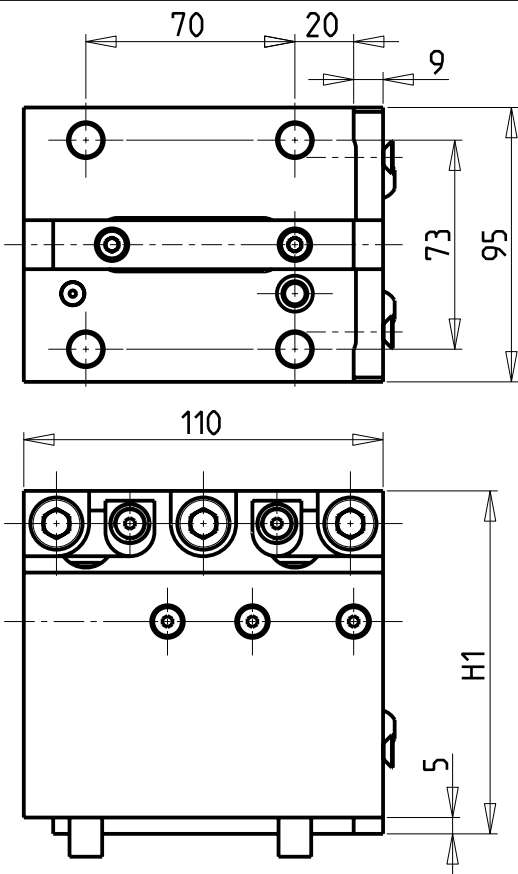

KIT ADDUZIONE INTERNA (OPZIONALE)
 KIT FOR INTERNAL COOLANT (OPTIONAL)
 KIT FUER INTERNE KUEHLMITTELZUFUHR (OPTIONAL)
 Ø1 1/2" cod. KIT1003004
 Ø40 cod. KIT1003003
 Ø50-Ø2" cod. KIT1003002

SOLO GUARNIZIONE (OPZIONALE)
 ONLY SEAL (OPTIONAL)
 NUR DICHTUNG (OPTIONAL)
 cod. 0520013

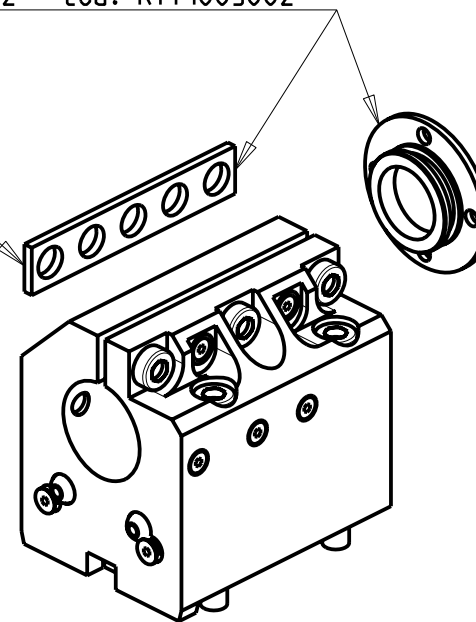

PER BOCCOLE DI RIDUZIONE VEDI PAG. TBL150-1-00
 FOR REDUCING BUSHINGS SEE PAGE TBL150-1-00
 FÜR REDUZIERBUCHSE SIEHE SEITE TBL150-1-00

Cod. MT	N°Utensili N°Tools N°Werkzeuge	Reversibile lato mandrino/contromandrino Reversible sub/main spindle side Umkehrbare Spindel-seite/ Gegenspindel-seite	Lubrificazione int. opzionale Coolant through optional Innenkuehlung Optional	Lubrificazione est. Ext. coolant Aussenkuehlung	Misure Dimensions Masse	D	H	H1
0834000	1	X	X	X	mm	40	40	117.5
0833810	1	X	X	X	Inch	1 1/2"	40	117.5
0835000	1	X	X	X	mm	50	46.5	123.5
0835080	1	X	X	X	Inch	2"	46.5	123.5

HYUNDAI-KIA (WIA)

MOD: SKT250MS - SKT300MS (L300MSA)

PORTAUTENSILE ASSIALE PER BARENO Ø40mm / Ø1 1/2" / Ø50mm / Ø2" H=72mm

Axial single boring bar holder Ø40mm / Ø1 1/2" / Ø50mm / Ø2" H=72mm

Axial Bohrhälter Ø40mm / Ø1 1/2" / Ø50mm / Ø2" H=72mm

M.T. srl

Via Casino Albini 480
 Tel. 0541/956034-957884
 Fax 0541/956341

47842 S. GIOVANNI IN M. (RN)
 e-mail: mtma@mtmarchetti.com
 http://www.mtmarchetti.com

PRODUZIONE MODULI ROTANTI



PAGINA KIA610-3-20

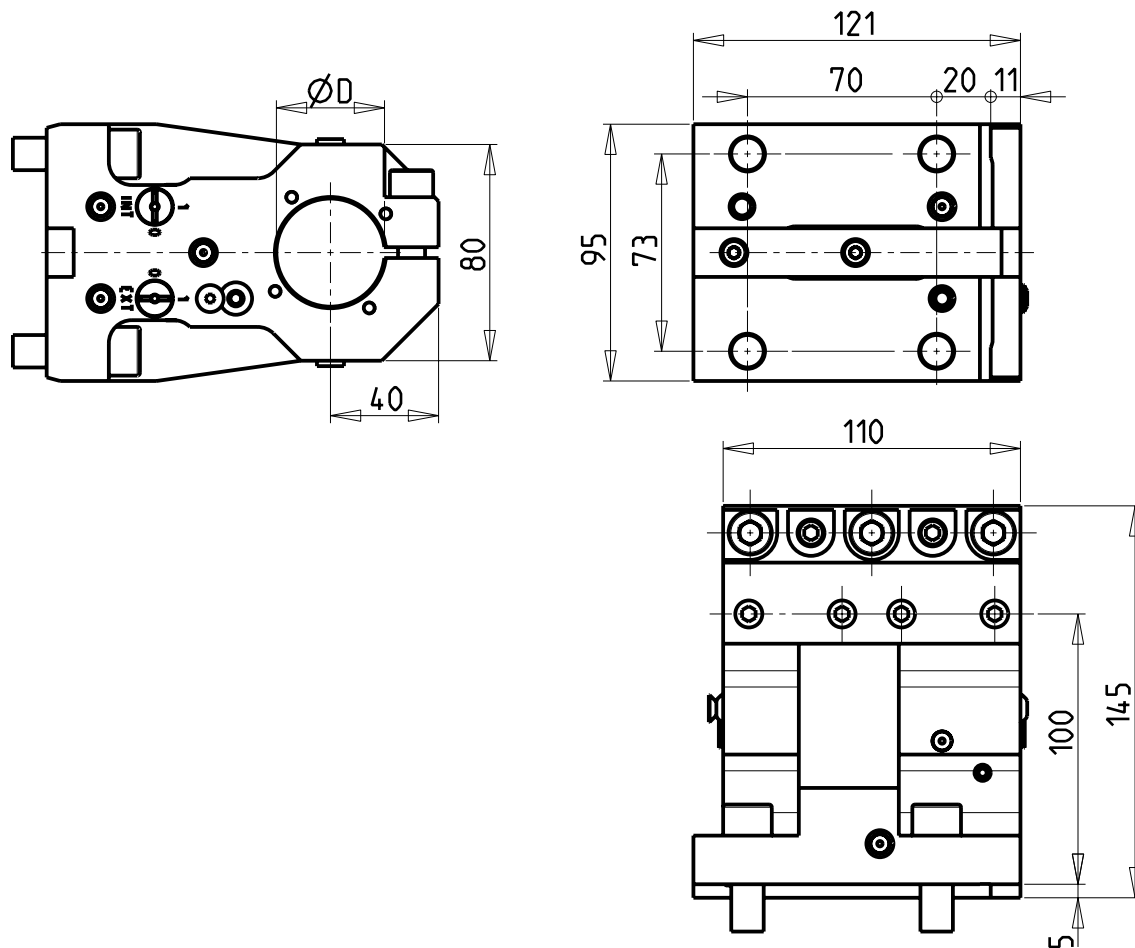

KIT ADDUZIONE INTERNA (OPZIONALE)
 KIT FOR INTERNAL COOLANT (OPTIONAL)
 KIT FUER INTERNE KUEHLMITTELZUFUHR (OPTIONAL)
 Ø40 cod. KIT1003003

SOLO GUARNIZIONE (OPZIONALE)
 ONLY SEAL (OPTIONAL)
 NUR DICHTUNG (OPTIONAL)
 cod. 0520013

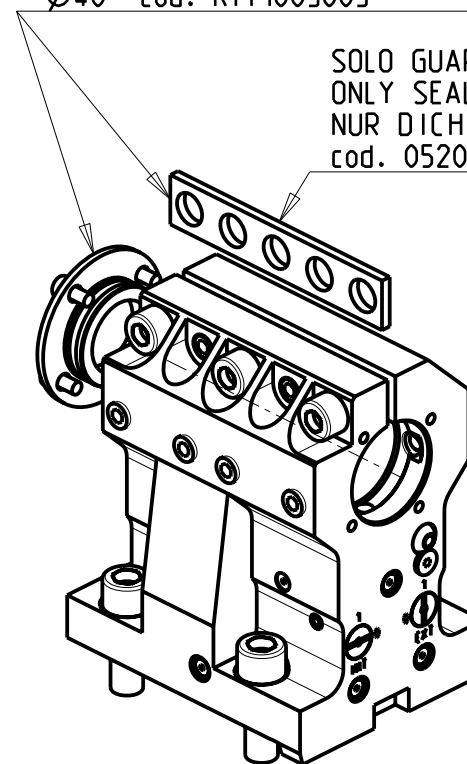

PER BOCCOLE DI RIDUZIONE VEDI PAG. TBL150-1-00
 FOR REDUCING BUSHINGS SEE PAGE TBL150-1-00
 FÜR REDUZIERBUCHSE SIEHE SEITE TBL150-1-00

Cod. MT	N°Utensili N°Tools N°Werkzeuge	Reversibile lato mandrino/contromandrino Reversible sub/main spindle side Umkehrbare Spindel-seite/ Gegenspindel-seite	Lubrificazione int. opzionale Coolant through optional Innenkuehlung Optional	Lubrificazione est. Ext. coolant Aussenkuehlung	Misure Dimensions Masse	D
DW00204000	1	X	X	X	mm	40

HYUNDAI-KIA (WIA)

SKT200TTM/TTMS/TTSY (LM2000TTM/TTMS/TTSY)
 SKT250TTM/TTMS/TTSY (LM2500TTM/TTMS/TTSY) - SKT250MS - SKT300MS (L300MSA)

PORTAUTENSILE ASSIALE PER BARENO Ø40mm H=100mm

Axial single boring bar holder Ø40mm H=100mm

Axial Bohrhalter Ø40mm H=100mm

M.T. srl

Via Casino Albini 480
 Tel. 0541/956034-957884
 Fax 0541/956341
 47842 S. GIOVANNI IN M. (RN)
 e-mail: mtma@mtmarchetti.com
 http://www.mtmarchetti.com

PRODUZIONE MODULI ROTANTI



PAGINA KIA640-3-20

KIT ADDUZIONE INTERNA (OPZIONALE)
 KIT FOR INTERNAL COOLANT (OPTIONAL)
 KIT FUER INTERNE KUEHLMITTELZUFUHR (OPTIONAL)
 cod. KIT1000001

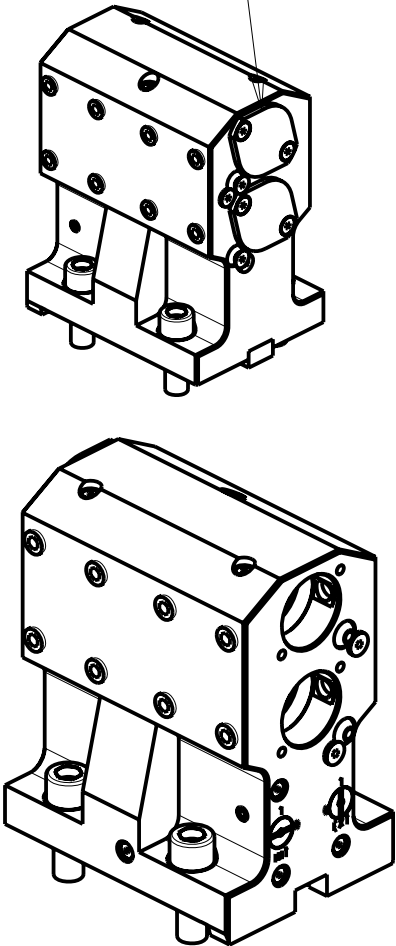
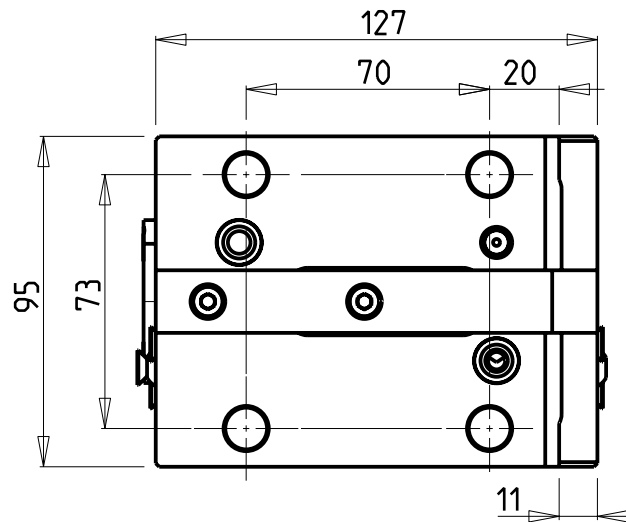
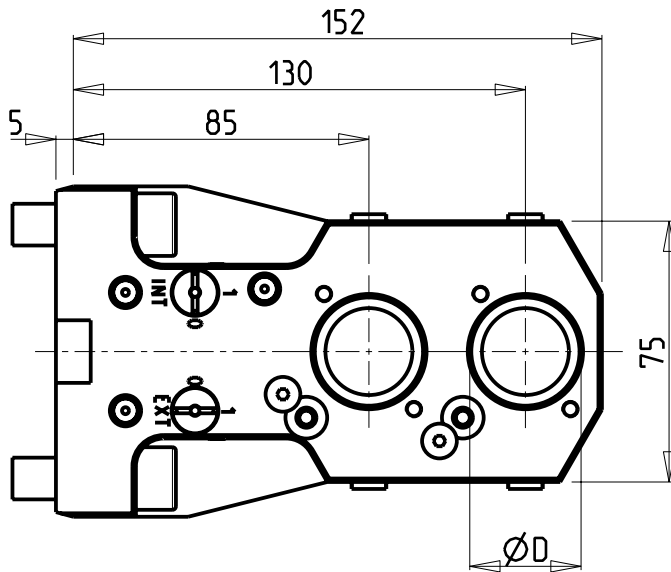

PER BOCCOLE DI RIDUZIONE VEDI PAG. TBL150-1-00
 FOR REDUCING BUSHINGS SEE PAGE TBL150-1-00
 FÜR REDUZIERBUCHSE SIEHE SEITE TBL150-1-00

Cod. MT	N°Utensili N°Tools N°Werkzeuge	Reversibile lato mandrino/contromandrino Reversible sub/main spindle side Umkehrbare Spindel-seite/ Gegenspindel-seite	Lubrificazione int. opzionale Coolant through optional Innenkuehlung Optional	Lubrificazione est. Ext. coolant Aussenkuehlung	Misure Dimensions Masse	Ø
DW 00213200	2+2	X	X	X	mm	32

HYUNDAI-KIA (WIA)
 MOD: SKT250MS - SKT300MS (L300MSA)

PORTAUTENSILE ASSIALE PER BARENO 2 POSIZIONI Ø32mm
 Axial double boring bar holder Ø32mm
 Axial Bohrhälter 2 Positionen Ø32mm

M.T. srl

Via Casino Albini 480
 Tel. 0541/956034-957884
 Fax 0541/956341
 47842 S. GIOVANNI IN M. (RN)
 e-mail: mtma@mtmarchetti.com
 http://www.mtmarchetti.com

PRODUZIONE MODULI ROTANTI



PAGINA KIA862-3-00

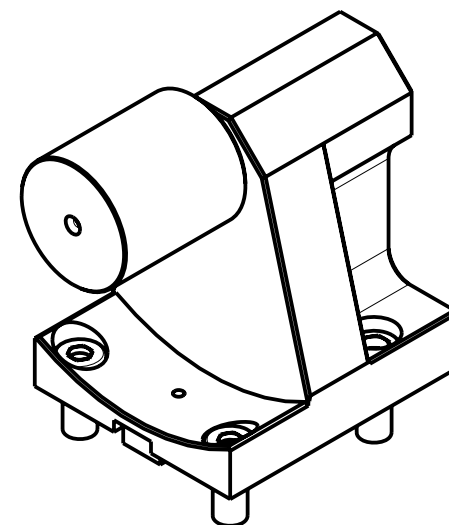
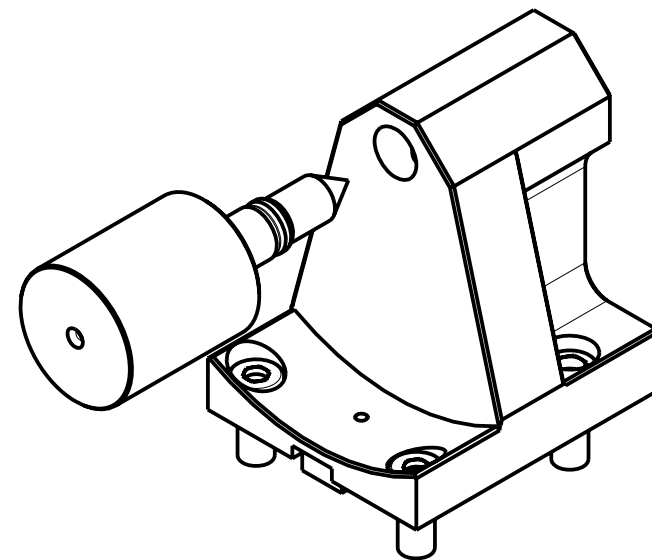
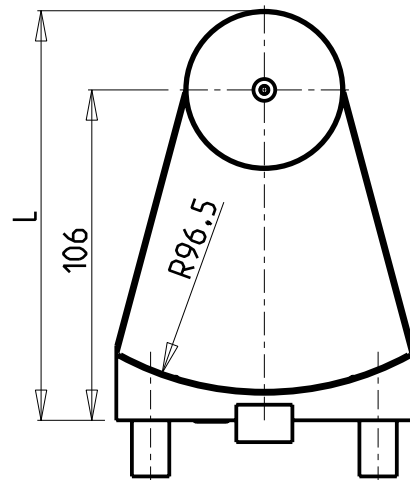
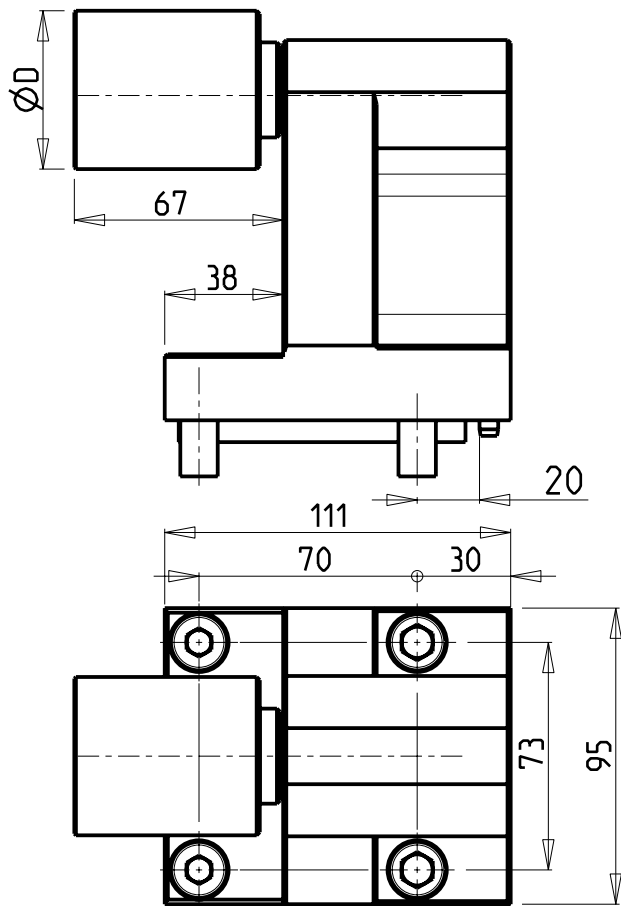

Cod. MT	N°Utensili N°Tools N°Werkzeuge	D	L
0820200	1	38	125
0820200L	1	2"	131.4

HYUNDAI-KIA (WIA)
 SKT200TTM/TTMS/TTSY (LM2000TTM/TTMS/TTSY)
 SKT250TTM/TTMS/TTSY (LM2500TTM/TTMS/TTSY) - SKT250MS - SKT300MS (L300MSA)
 CONTROPUNTA PER CONTROMANDRINO
 Tailstock for subspindle
 Gegenspitz fuer Gegenspindel

M.T. srl
 Via Casino Albini 480
 Tel. 0541/956034-957884
 Fax 0541/956341
 47842 S. GIOVANNI IN M. (RN)
 e-mail: mtma@mtmarchetti.com
 http://www.mtmarchetti.com

PRODUZIONE MODULI ROTANTI

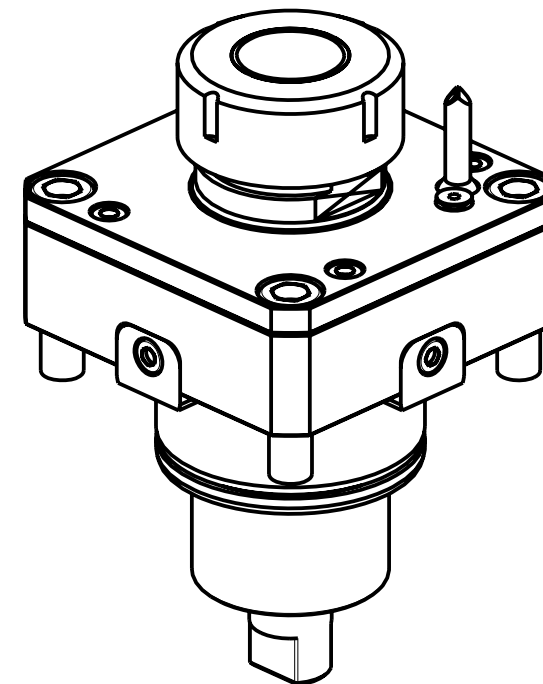
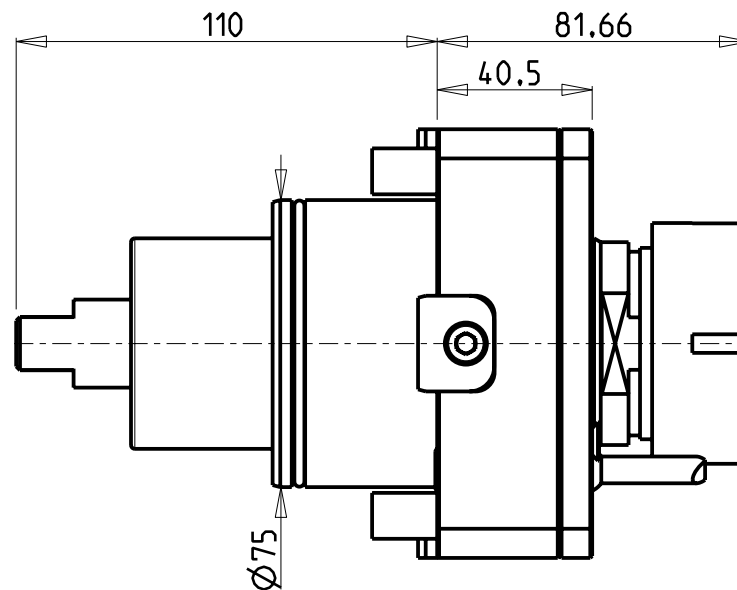
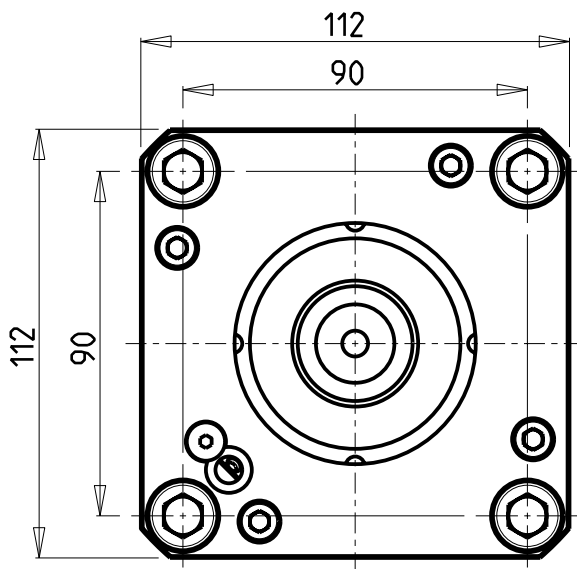
 PAGINA KIA950-3-00



Cod. MT	Mandrino Spindle Spindel	I	RPM	Coppia Max Max Torque Max Drehmoment	Lubrificazione int. Coolant through Innenkuehlung	Lubrificazione est. Ext. coolant Aussenkuehlung	CHIAVI NON INCLUSE Keys not included Schluessel nicht einbegriffen	
							CHSTER40	CHUB46 o 0290018
0291540	ER40	1:1	6000	100Nm		X	CHSTER40	CHUB46 o 0290018
0291040	ER40	1:1	6000	100Nm	P=30bar		CHSTER40	CHUB46 o 0290018

HYUNDAI-KIA (WIA)
MOD: SKT400M (L400MA) (LV500RM/LM - LV800RM/LM)

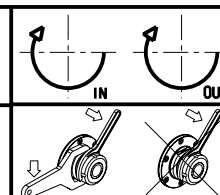
MODULO MOTORIZZATO RADIALE
Radial driven tool
Radial angetriebenes Werkzeug



M.T. srl
Via Casino Albini 480
Tel. 0541/956034-957884
Fax 0541/956341
47842 S. GIOVANNI IN M. (RN)
e-mail: mtma@mtmarchetti.com
http://www.mtmarchetti.com

PRODUZIONE MODULI ROTANTI



PAGINA KIA010-4-00

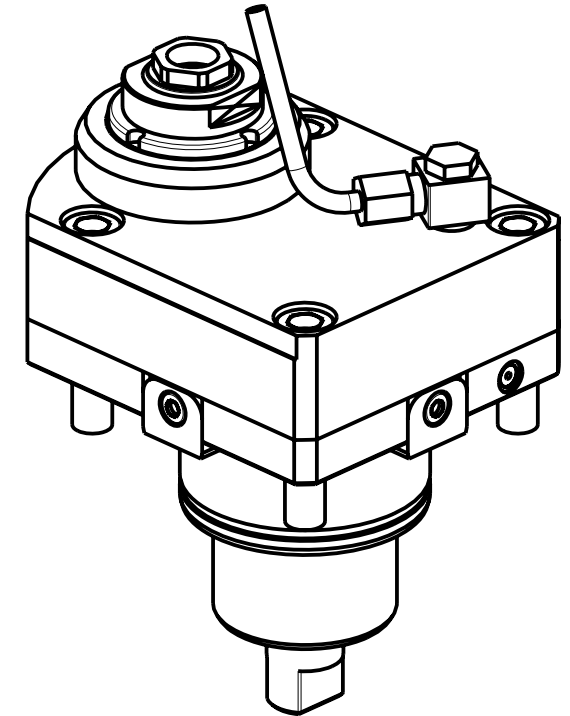
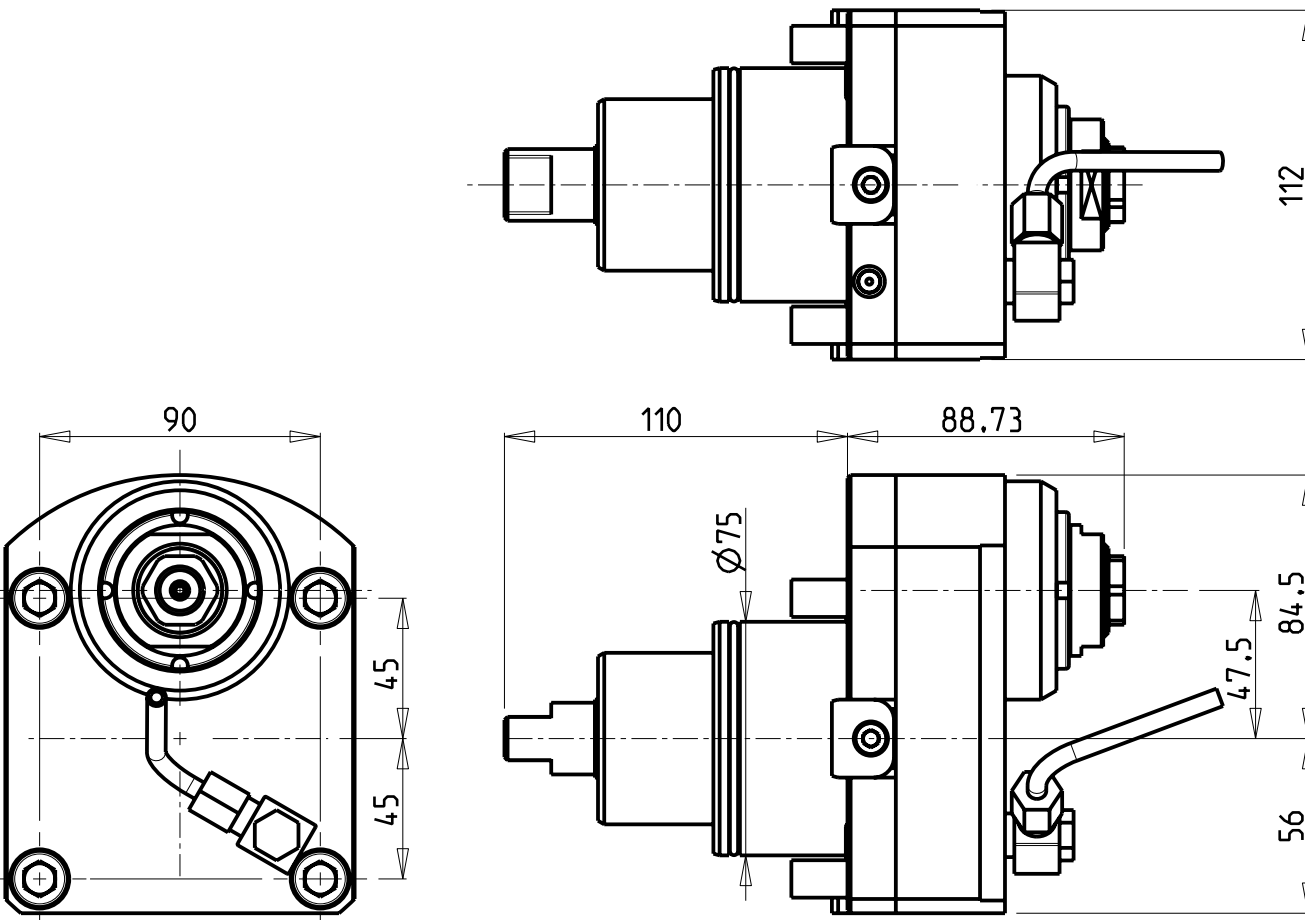

Cod. MT	Mandrino Spindle Spindel	I	RPM	Coppia Max Max Torque Max Drehmoment	Reversibile lato mandrino/contromandrino Reversible sub/main spindle side Umkehrbare Spindelseite/ Gegenspindelseite	Lubr. esterna Ext. coolant Aussenkuehlung	CHIAVI NON INCLUSE Keys not included Schluessel nicht einbegriffen
DW00430120	ERA20	1:1	6000	80Nm	X	X	CHUB36 CHUB22

HYUNDAI-KIA (WIA)
MOD: SKT400M (L400MA) (LV500RM/LM - LV800RM/LM)

MODULO MOTORIZZATO RADIALE DISASSATO IN Z 47.5mm
Radial driven tool re-directed in Z by 47.5mm
Radial angetriebenes Werkzeug achsversetzt in Z um 47.5mm

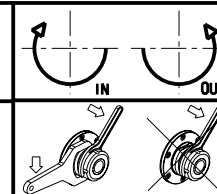

M.T. srl
Via Casino Albini 480
Tel. 0541/956034-957884
Fax 0541/956341
47842 S. GIOVANNI IN M. (RN)
e-mail: mtma@mtmarchetti.com
http://www.mtmarchetti.com

PRODUZIONE MODULI ROTANTI



PAGINA KIA033-4-10

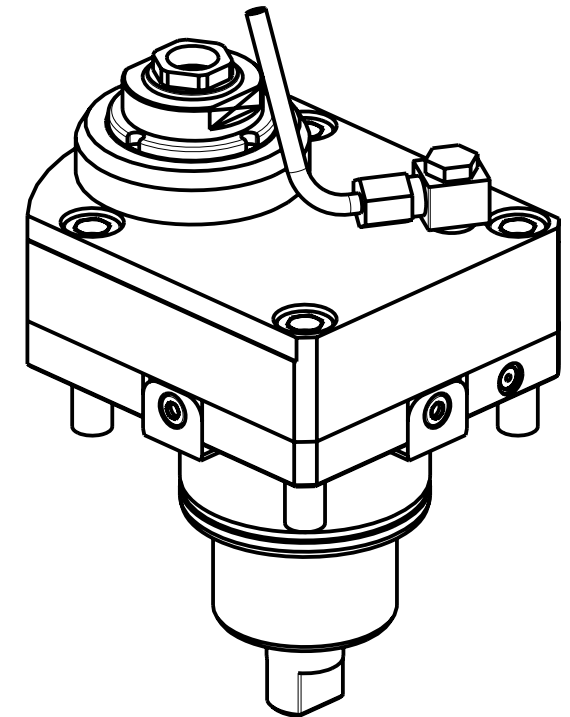
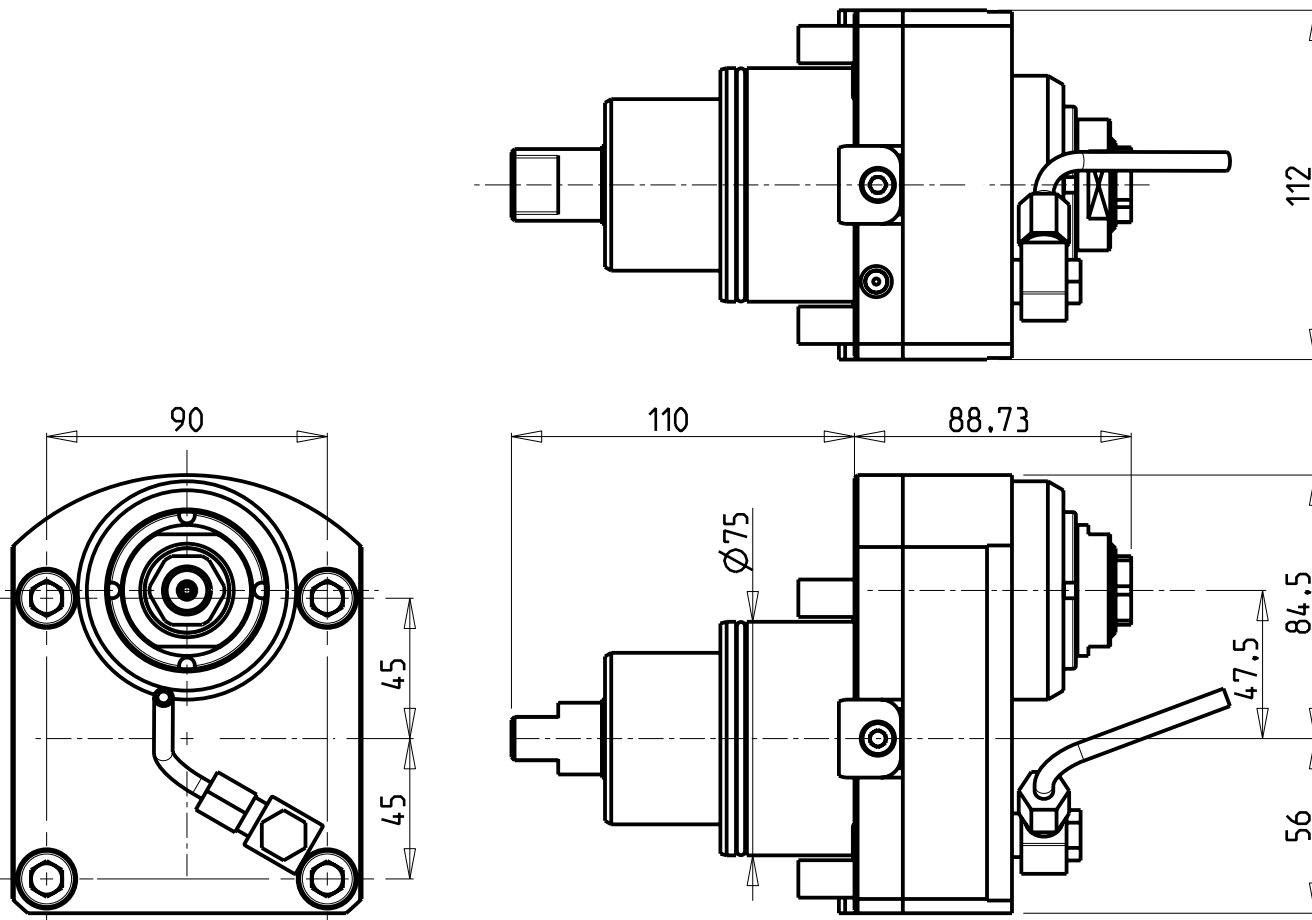

Cod. MT	Mandrino Spindle Spindel	I	RPM	Coppia Max Max Torque Max Drehmoment	Reversibile lato mandrino/controlmandrino Reversible sub/main spindle side Umkehrbare Spindelseite/ Gegenspindelseite	Lubr. esterna Ext. coolant Aussenkuehlung	CHIAVI NON INCLUSE Keys not included Schluessel nicht einbegriffen
DW00430220	ERA20	1:2	12000	50Nm	X	X	CHUB36 CHUB22

HYUNDAI-KIA (WIA)
 MOD: SKT400M (L400MA) (LV500RM/LM - LV800RM/LM)
 MODULO MOTORIZZATO RADIALE MOLTIPLICATO I=1:2 DISASSATO IN Z 47.5mm
 Radial geared-up I=1:2 driven tool re-directed in Z by 47.5mm
 Radial angetriebenes Werkzeug uebersetzt I=1:2 achsversetzt in Z um 47.5mm

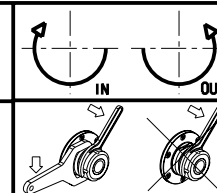

M.T. srl
 Via Casino Albini 480
 Tel. 0541/956034-957884
 Fax 0541/956341
 47842 S. GIOVANNI IN M. (RN)
 e-mail: mtma@mtmarchetti.com
 http://www.mtmarchetti.com

PRODUZIONE MODULI ROTANTI



PAGINA KIA033-4-30

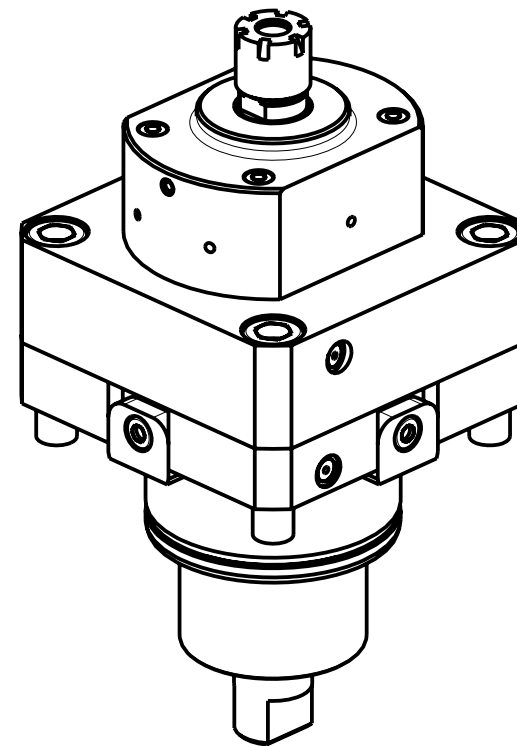
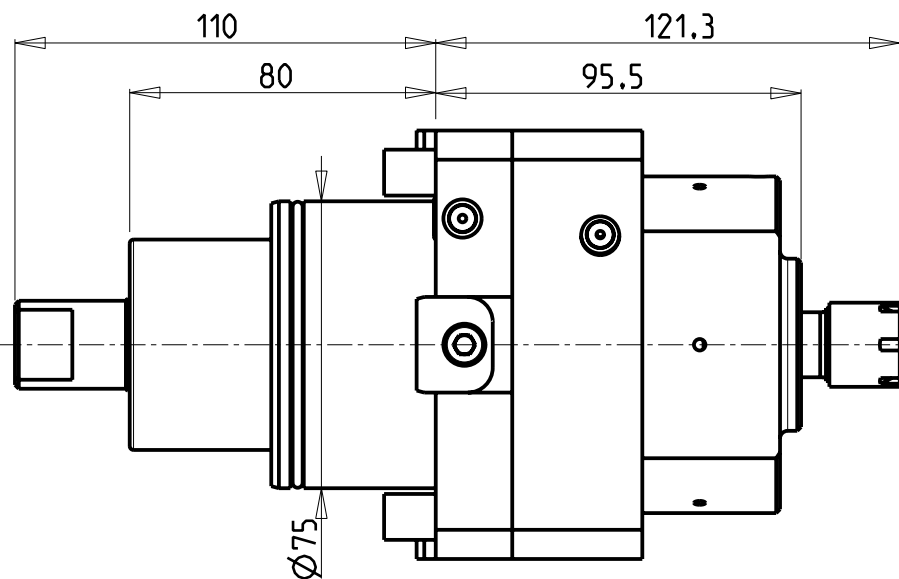
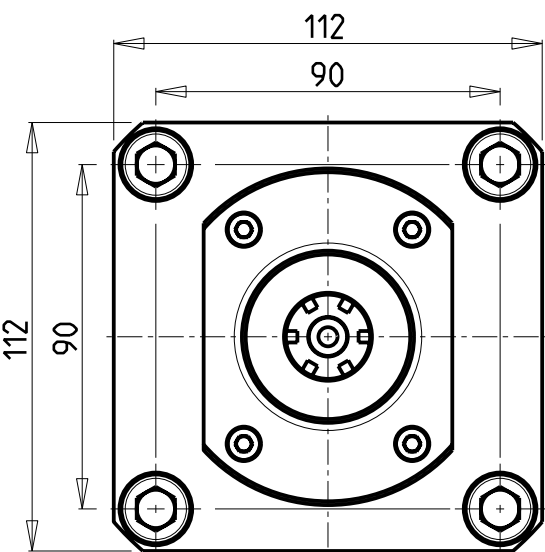

ATTENZIONE - ATTENTION - ACHTUNG

- PRIMA DI UTILIZZARE IL MOTORIZZATO CONSULTARE LE ISTRUZIONI ALLEGATE!
- BEFORE USING THE DRIVEN TOOL, PLEASE CHECK THE ENCLOSED INSTRUCTION SHEET!
- VOR DER BENUTZUNG DES ANGETRIEBENEN WERKZEUGES, DIE BEILIEGENDEN INSTRUKTIONEN DURCHLESEN!

ATTENZIONE - ATTENTION - ACHTUNG

- Per lo smontaggio degli utensili utilizzare sempre la chiave di contrasto come indicato nel manuale d'uso.
- For disassembly of the tools use always the contrast key as mentioned in the user instructions.
- Fuer das Abmontieren der Werkzeuge immer den Gegenschlüssel benutzen wie in der Bedienungsanleitung erwähnt.

Cod. MT	Mandrino Spindle Spindel	I	RPM	Coppia Max Max Torque Max Drehmoment	Lubrificazione int. Coolant through Innenkuehlung	CHIAVI INCLUSE Keys included Schluessel einbegriffen	
DW00450116	ER16	1:4	12000	15Nm	P=30bar	CHMNER16	CHUB17

HYUNDAI-KIA (WIA)
 MOD: SKT400M (L400MA) (LV500RM/LM - LV800RM/LM)

MODULO MOTORIZZATO RADIALE MOLTIPLICATO I=1:4
 Radial geared-up I=1:4 driven tool
 Radial angetriebenes Werkzeug uebersetzt I=1:4

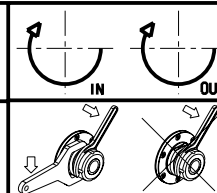

M.T. srl
 Via Casino Albini 480
 Tel. 0541/956034-957884
 Fax 0541/956341
 47842 S. GIOVANNI IN M. (RN)
 e-mail: mtma@mtmarchetti.com
 http://www.mtmarchetti.com

PRODUZIONE MODULI ROTANTI



PAGINA KIA058-4-00

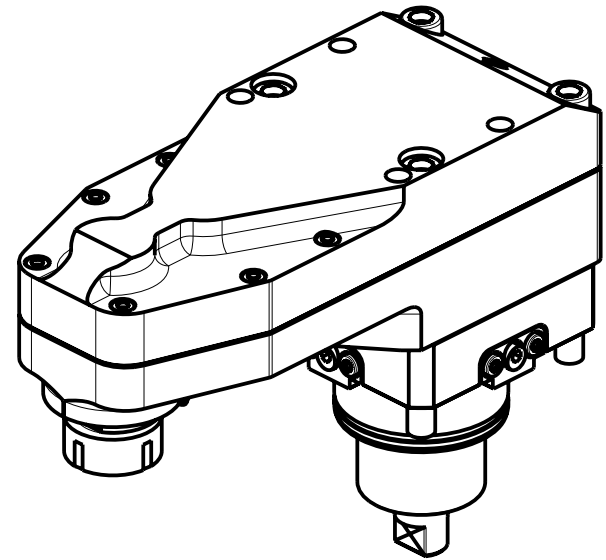
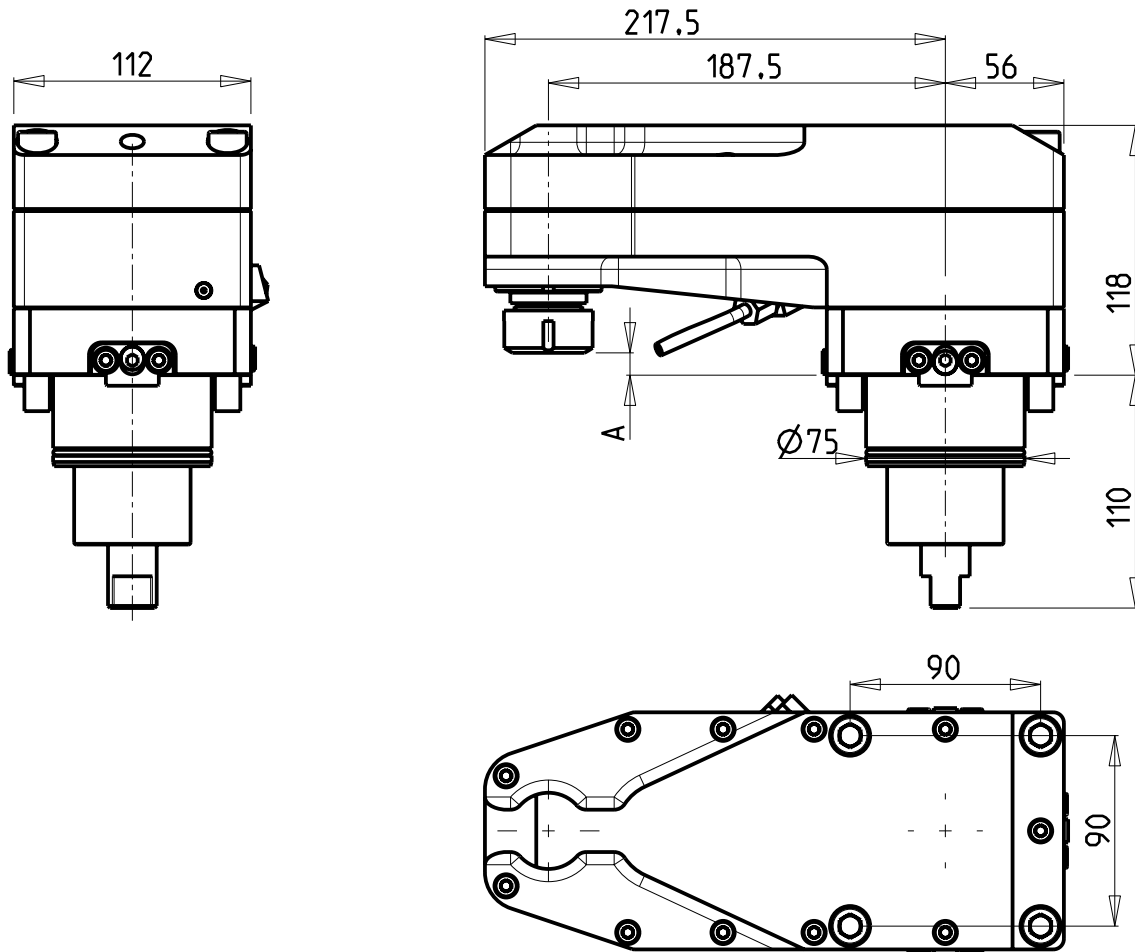

Cod. MT	Mandrino Spindle Spindel	I	RPM MAX	Coppia Max Max Torque Max Drehmoment	Lubrificazione est. Ext. coolant Ausseinkuehlung	A	CHIAVI NON INCLUSE Keys not included Schlüssel nicht einbegriffen	
0841225	ER25	1:2	8000	40Nm	X	8.84	CHSTER25	CHUB36
0841232	ER32	1:2	8000	40Nm	X	3.66	CHSTER32	CHUB36

HYUNDAI-KIA (WIA)

MOD: SKT400M (L400MA) (LV500RM/LM - LV800RM/LM)

MODULO MOTORIZZATO RADIALE ROVESCiato DISASSATO IN Z 187.5mm

Radial inverted driven tool re-directed in Z by 187.5mm

Radial angetriebenes Werkzeug ungekehrt achsversetzt in Z um 187.5mm

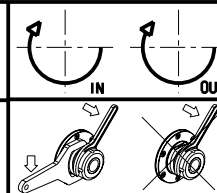

M.T. srl

Via Casino Albini 480
Tel. 0541/956034-957884

Fax 0541/956341

47842 S. GIOVANNI IN M. (RN)

e-mail: mtma@mtmarchetti.com

http://www.mtmarchetti.com

PRODUZIONE MODULI ROTANTI



PAGINA KIA120-4-10

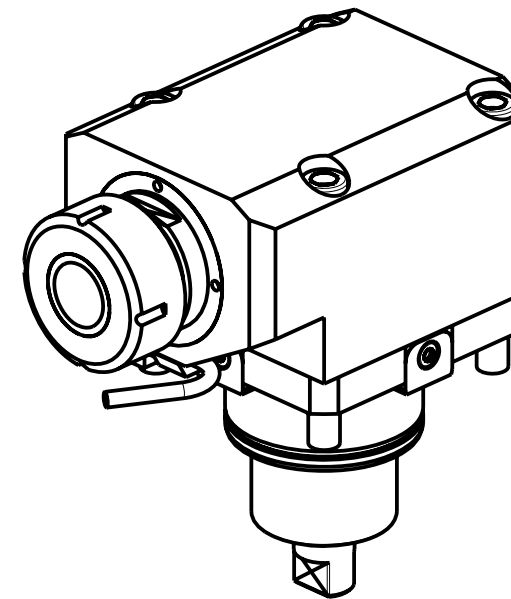
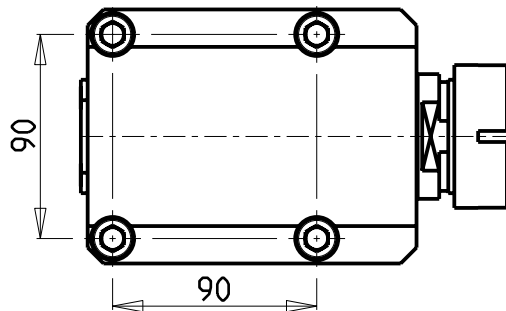
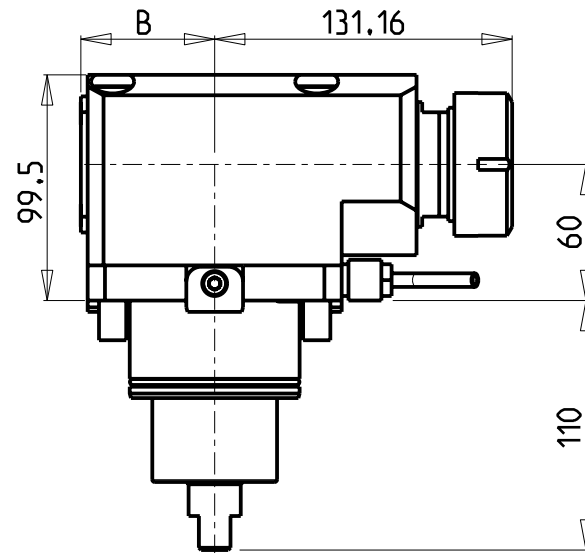
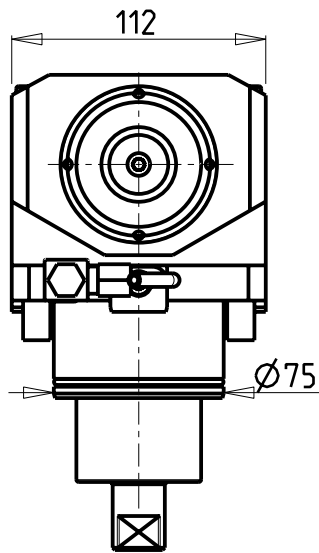

Cod. MT	Cod. EPPINGER	Mandrino Spindle Spindel	I	RPM	Coppia Max Max Torque Max Drehmoment	Lubrificazione int. Coolant through Innenkuehlung	Lubrificazione est. Ext. coolant Aussenkuehlung	B	CHIAVI NON INCLUSE Keys not included Schlüssel nicht einbegriffen	
									CHSTER40	CHUB46
0330840	7.070.935	ER40	1:1	6000	100Nm		X	59	CHSTER40	CHUB46
0331040	-	ER40	1:1	6000	100Nm	P=70bar	X	85	CHSTER40	CHUB46

HYUNDAI-KIA (WIA)

MOD: (LV800RM/LM)

MODULO MOTORIZZATO ASSIALE H=60mm

Axial driven tool H=60mm

Axial angetriebenes Werkzeug H=60mm

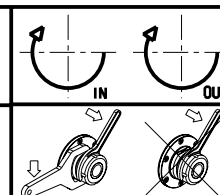

M.T. srl

Via Casino Albini 480
Tel. 0541/956034-957884

Fax 0541/956341

47842 S. GIOVANNI IN M. (RN)

e-mail: mtma@mtmarchetti.com

http://www.mtmarchetti.com

PRODUZIONE MODULI ROTANTI



PAGINA KIA150-4-10

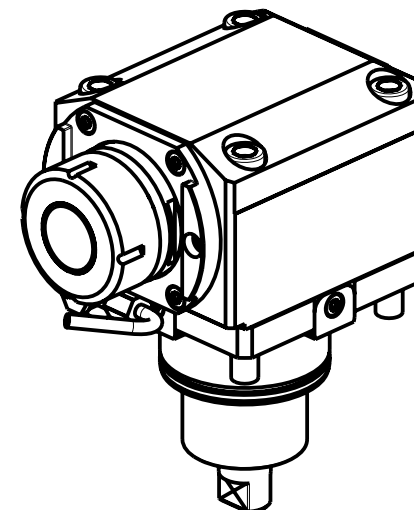
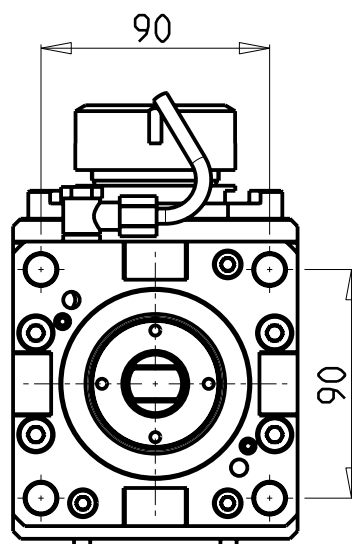
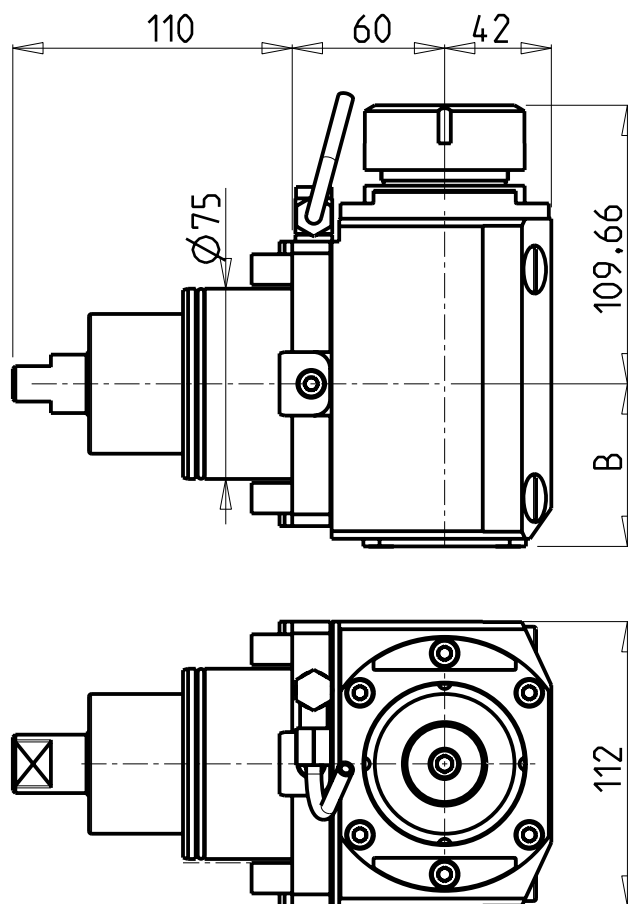

CUSCINETTI MAGGIORATI PER LAVORAZIONI PESANTI

Reinforced bearings for
heavy machining

Vergroesserte Lager fuer
schwerere Bearbeitungen

Cod. MT	Mandrino Spindle Spindel	I	RPM	Coppia Max Max Torque Max Drehmoment	Lubrificazione int. Coolant through Innenkuehlung	Lubrificazione est. Ext. coolant Aussenkuehlung	B	CHIAVI NON INCLUSE Keys not included Schlüssel nicht einbegriffen	
								CHSTER40	OKU0430007 •
DW00680140	ER40	1:1	6000	100Nm		X	64	CHSTER40	OKU0430007 •
DW00680240	ER40	1:1	6000	100Nm	P=70bar	X	77.5	CHSTER40	OKU0430007 •

- Chiave inclusa
- Key included
- Schlüssel inbegriffen

HYUNDAI-KIA (WIA)

MOD: (LV800RM/LM)

MODULO MOTORIZZATO ASSIALE MAGGIORATO H=60mm

Axial reinforced driven tool H=60mm

Axial angetriebenes Werkzeug vergroessert H=60mm

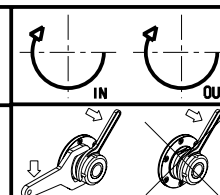

M.T. srl

Via Casino Albini 480
Tel. 0541/956034-957884
Fax 0541/956341

47842 S. GIOVANNI IN M. (RN)
e-mail: mtma@mtmarchetti.com
http://www.mtmarchetti.com

PRODUZIONE MODULI ROTANTI



PAGINA KIA170-4-10

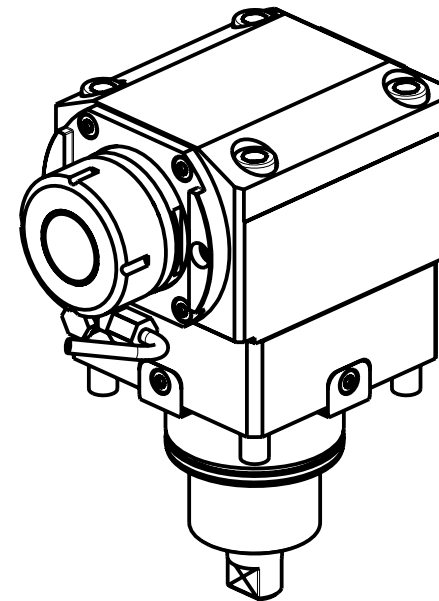
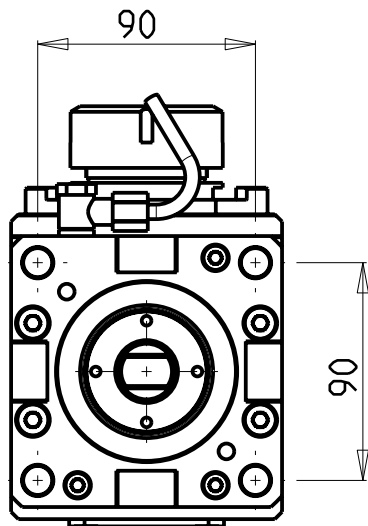
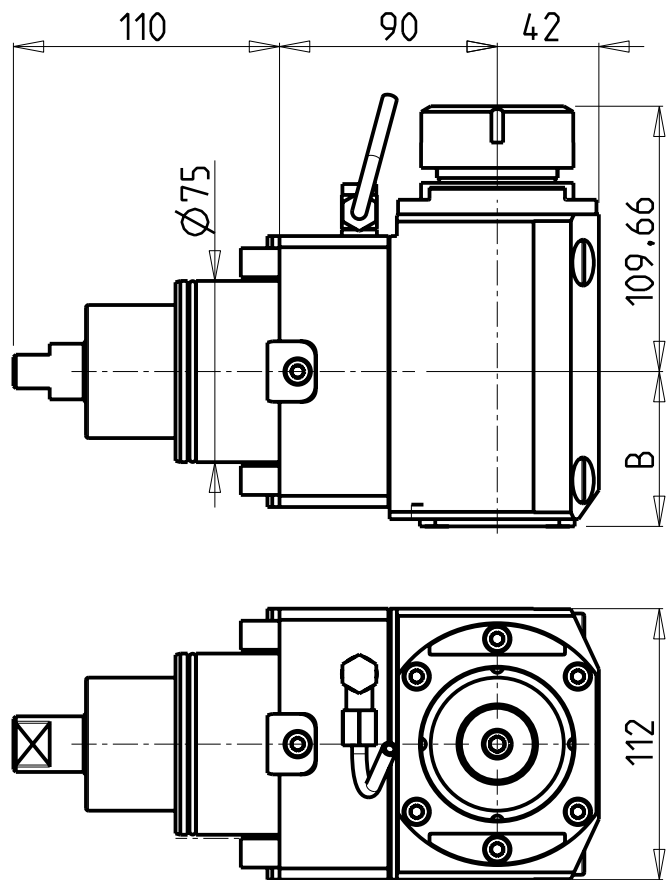

CUSCINETTI MAGGIORATI PER LAVORAZIONI PESANTI

Reinforced bearings for
heavy machining

Vergroesserte Lager fuer
schwerere Bearbeitungen

Cod. MT	Mandrino Spindle Spindel	I	RPM	Coppia Max Max Torque Max Drehmoment	Lubrificazione int. Coolant through Innenkuehlung	Lubrificazione est. Ext. coolant Aussenkuehlung	B	CHIAVI NON INCLUSE Keys not included Schlüssel nicht einbegriffen	
								CHSTER40	OKU0430007
DW00650140	ER40	1:1	6000	100Nm		X	64	CHSTER40	OKU0430007
DW00650240	ER40	1:1	6000	100Nm	P=70bar	X	77.5	CHSTER40	OKU0430007

• Chiave inclusa
• Key included
• Schlüssel inbegriffen

HYUNDAI-KIA (WIA)
MOD: SKT400M (L400MA) (LV500RM/LM - LV800RM/LM)

MODULO MOTORIZZATO ASSIALE MAGGIORATO
Axial reinforced driven tool
Axial angetriebenes Werkzeug vergroessert

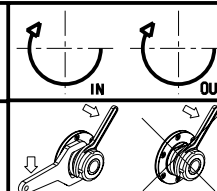

M.T. srl

Via Casino Albini 480
Tel. 0541/956034-957884
Fax 0541/956341

47842 S. GIOVANNI IN M. (RN)
e-mail: mtma@mtmarchetti.com
http://www.mtmarchetti.com

PRODUZIONE MODULI ROTANTI



PAGINA KIA170-4-20

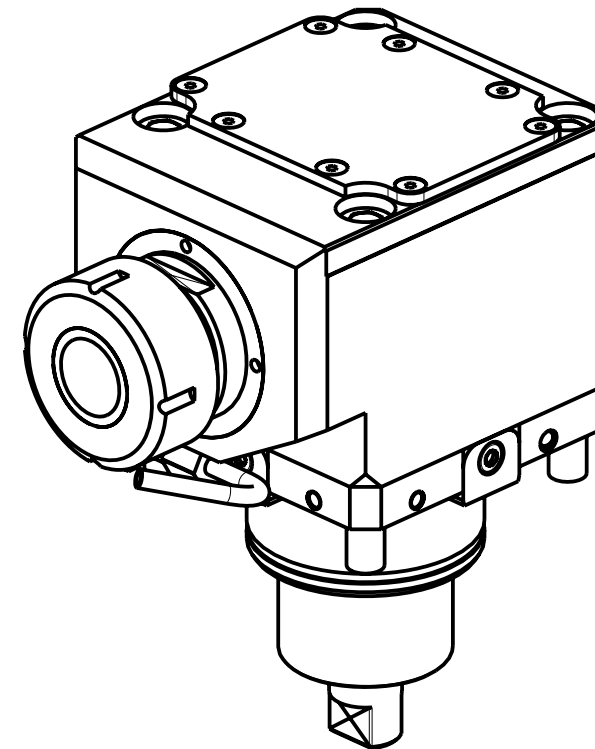
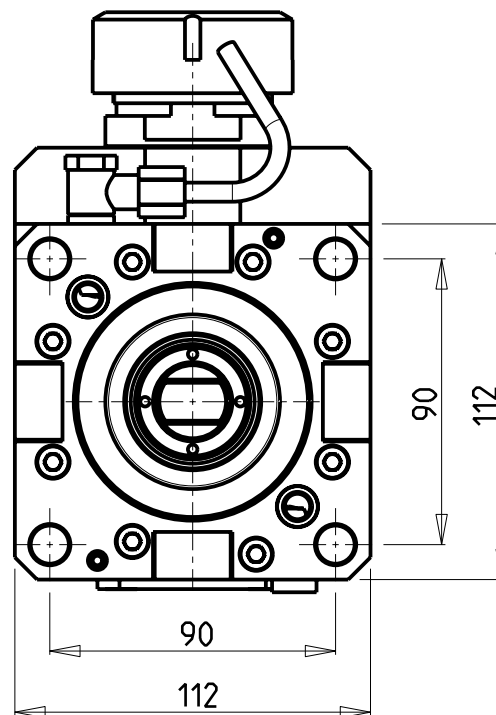
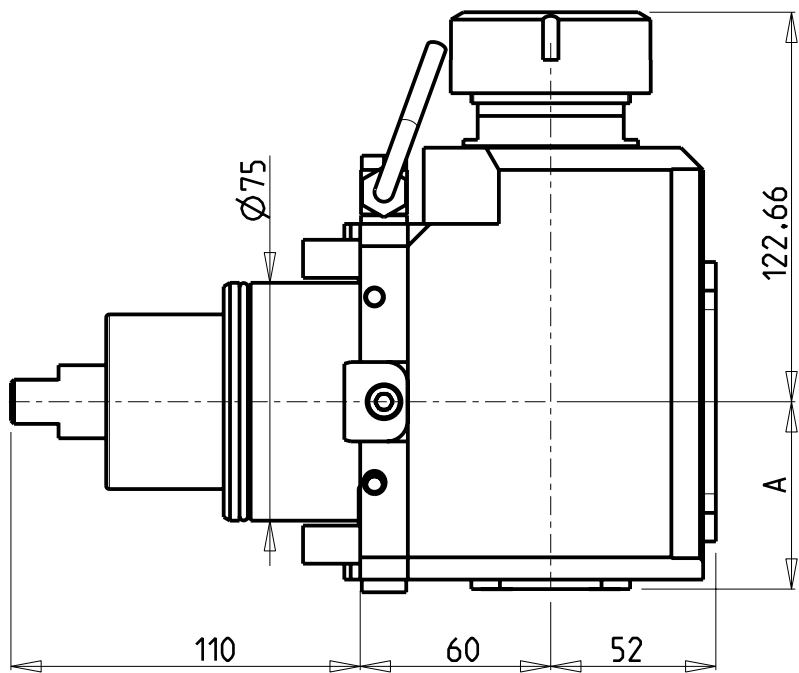

Cod. MT	Mandrino Spindle Spindel	I	RPM	Coppia Max Max Torque Max Drehmoment	Reversibile lato mandrino/contromandrino Reversible sub/main spindle side Umkehrbare Spindel-seite/ Gegenspindel-seite	Lubrificazione int. Coolant through Innenkühlung	Lubrificazione est. Ext. coolant Aussenkühlung	A	CHIAVI NON INCLUSE Keys not included Schlüssel nicht einbegriffen	
DW00470140	ER40	2:1	3000	140Nm	X		X	59	CHUB46	CHSTER40
DW00470240	ER40	2:1	3000	140Nm	X	P=70bar	X	72.5	CHUB46	CHSTER40

HYUNDAI-KIA (WIA)

MOD: (LV800RM/LM)

MODULO MOTORIZZATO ASSIALE RIDOTTO I=2:1

Axial geared-down I=2:1 driven tool

Axial angetriebenes Werkzeug untersetzt I=2:1

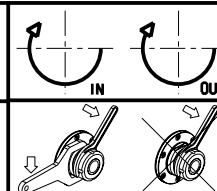

M.T. srl

Via Casino Albini 480
Tel. 0541/956034-957884
Fax 0541/956341

47842 S. GIOVANNI IN M. (RN)
e-mail: mtma@mtmarchetti.com
http://www.mtmarchetti.com

PRODUZIONE MODULI ROTANTI



PAGINA KIA190-4-10

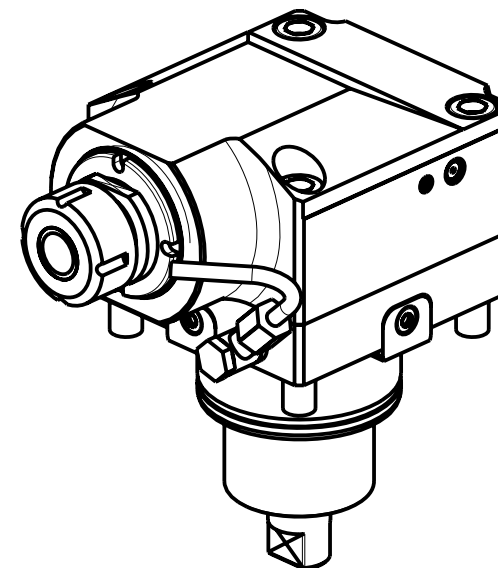
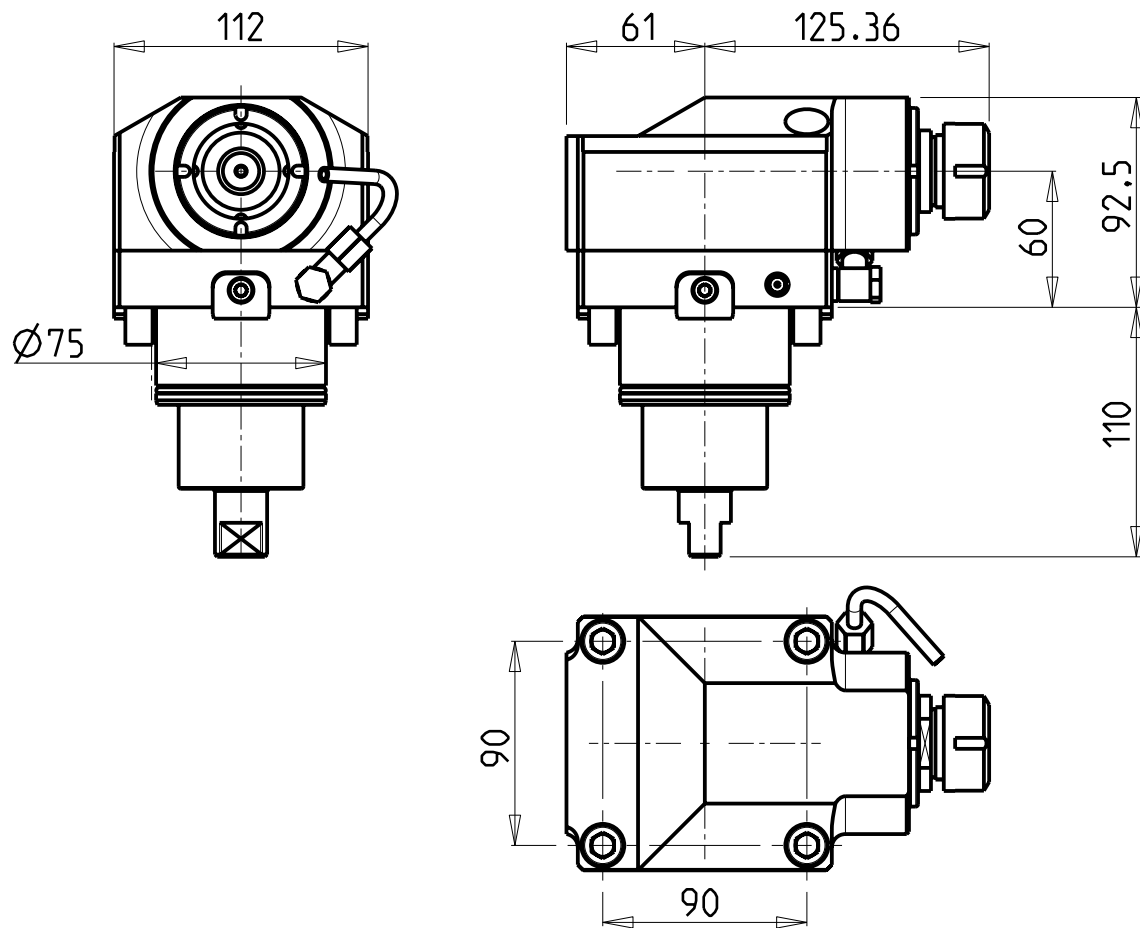

Cod. MT	Mandrino Spindel Spindel	i	RPM MAX	Coppia Max Max Torque Max Drehmoment	Lubrificazione int. Coolant through Innenkuehlung	Lubrificazione est. Ext. coolant Aussenkuehlung	CHIAVI NON INCLUSE Keys not included Schlüssel nicht einbegriffen	
							CHSTER25	CHUB36
DW00570125	ER25	1:3	12000	60Nm		X	CHSTER25	CHUB36
DW00570225	ER25	1:3	12000	60Nm	P=70bar	X	CHSTER25	CHUB36

HYUNDAI-KIA (WIA)

MOD: (LV800RM/LM)

MODULO MOTORIZZATO ASSIALE MOLTIPLICATO I=1:3

Axial geared-up I=1:3 driven tool

Axial angetriebenes Werkzeug uebersetzt I=1:3

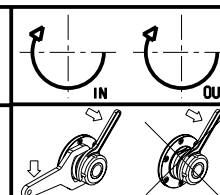

M.T. srl

Via Casino Albini 480
Tel. 0541/956034-957884
Fax 0541/956341

47842 S. GIOVANNI IN M. (RN)
e-mail: mtma@mtmarchetti.com
http://www.mtmarchetti.com

PRODUZIONE MODULI ROTANTI



PAGINA KIA205-4-10

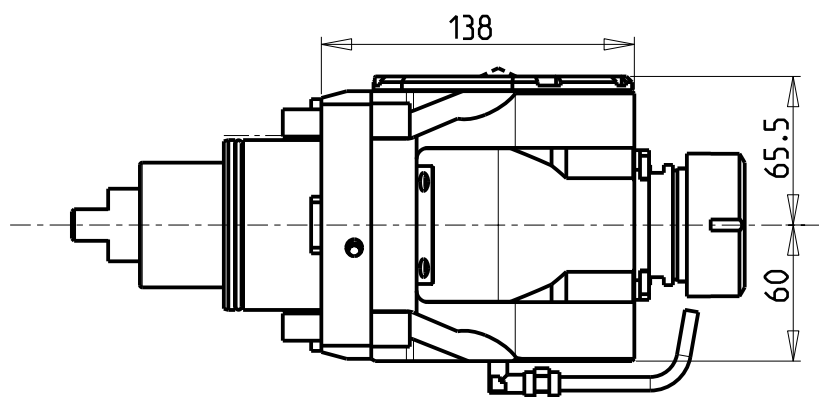
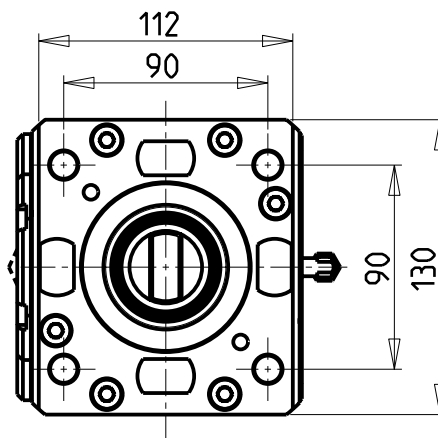
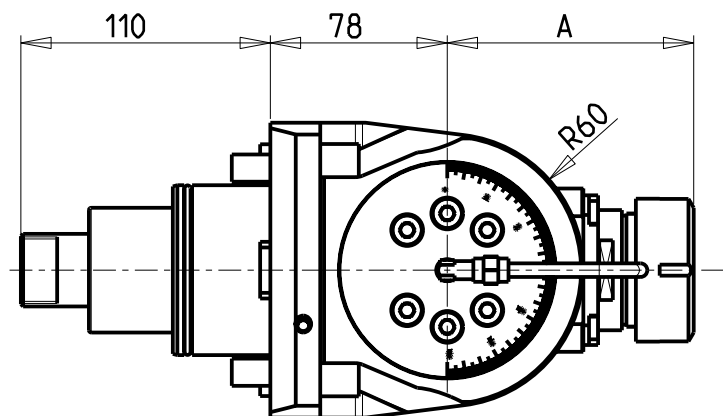

ATTENZIONE - ATTENTION - ACHTUNG

- VERIFICARE LE MISURE DI INGOMBRO PER POSSIBILE INTERFERENZA SU ALCUNI MODELLI DI MACCHINE
- Please check the overall sizes for possible interferences on some machine models
- Bitte überprüfen sie das ausmass um mögliche interferenzen auf einigen maschinen modellen zu vermeiden

ATTENZIONE - ATTENTION - ACHTUNG

- Su macchine SKT400 (L400MA) non arriva in centro mandrino
- On machines SKT400 (L400MA) tool does not get to the centre of the spindle axis.
- Auf Maschinen SKT400 (L400MA) erreicht das Werkzeug nicht die Mitte der Werkzeug-Achse.

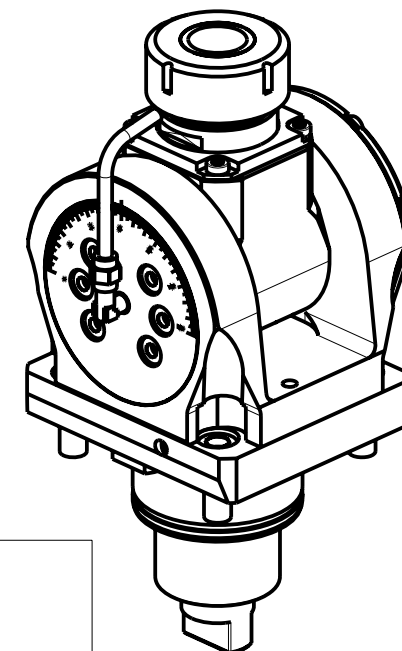

Cod. MT	Mandrino Spindel Spindel	I	RPM	Coppia Max Max Torque Max Drehmoment	Lubrificazione int. Coolant through Innenkuehlung	Lubrificazione est. Ext. coolant Aussenkuehlung	A	CHIAVI INCLUSE Keys included Schluessel inbegriffen					
								CHUB30	CHUB46	CHTAER32ZC	CHESL10		CHESL06
DW00820332	ERA32	1:1	6000	50Nm		X	81	CHUB30	CHUB46	CHTAER32ZC	CHESL10	CHESL06	NEW
DW00820432	ERA32	1:1	6000	50Nm	P=70bar	X	81	CHUB30	CHUB46	CHTAER32ZC	CHESL10	CHESL06	NEW
DW00820140	ER40	1:1	6000	50Nm		X	108.66	-	CHUB46	CHSTER40	CHESL10	CHESL06	NEW
DW00820240	ER40	1:1	6000	50Nm	P=70bar	X	108.66	-	CHUB46	CHSTER40	CHESL10	CHESL06	NEW

HYUNDAI-KIA (WIA)

MOD: SKT400M (L400MA) (LV500RM/LM - LV800RM/LM)

MODULO MOTORIZZATO ORIENTABILE +/-90°

+/-90° adjustable angle driven tool

Angetriebenes Werkzeug schwenkbar +/-90°

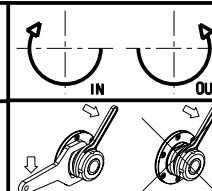

M.T. srl

Via Casino Albini 480
Tel. 0541/956034-957884

Fax 0541/956341

47842 S. GIOVANNI IN M. (RN)

e-mail: mtma@mtmarchetti.com

http://www.mtmarchetti.com

PRODUZIONE MODULI ROTANTI



PAGINA KIA339-4-00

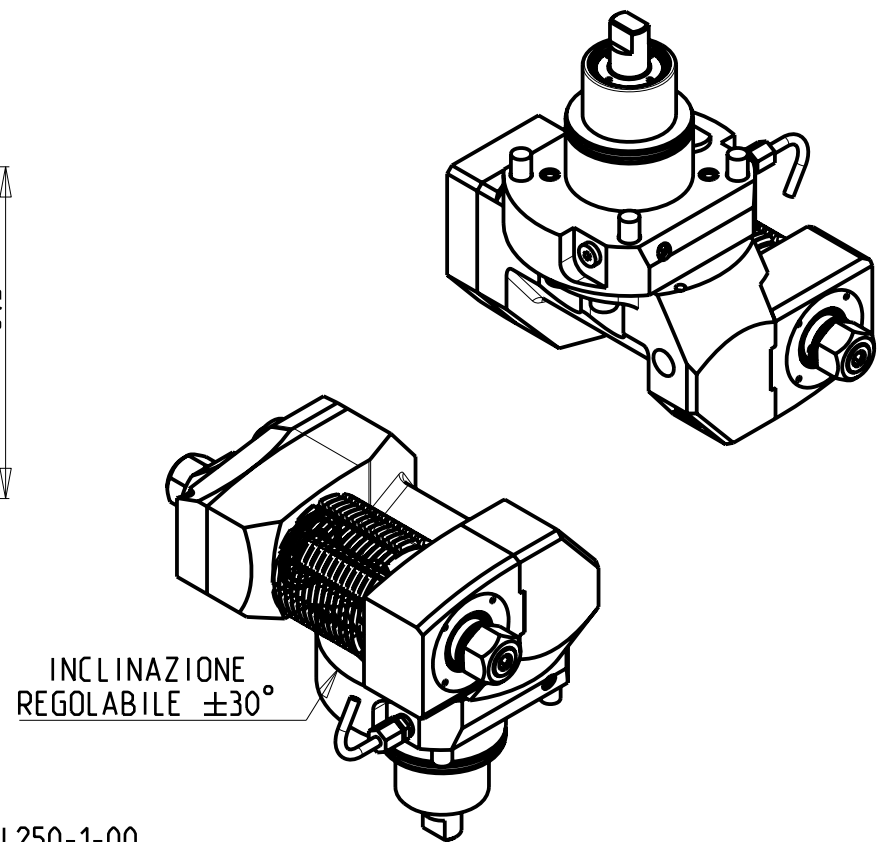
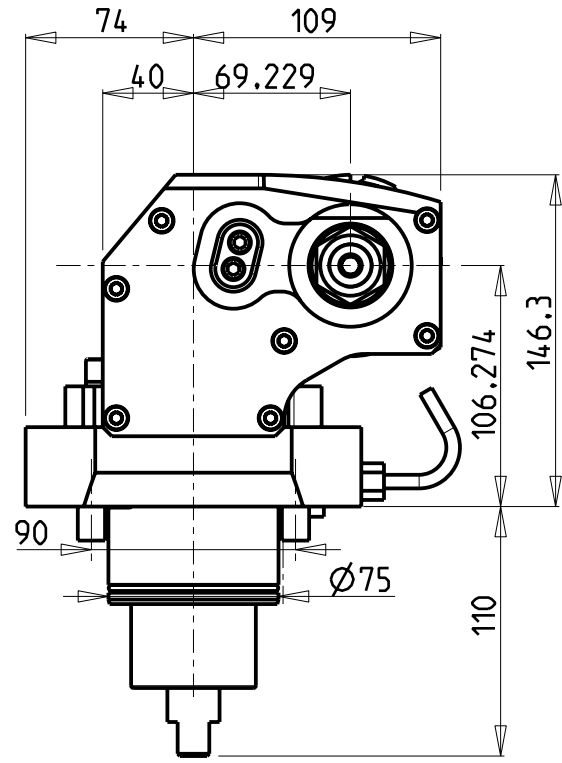
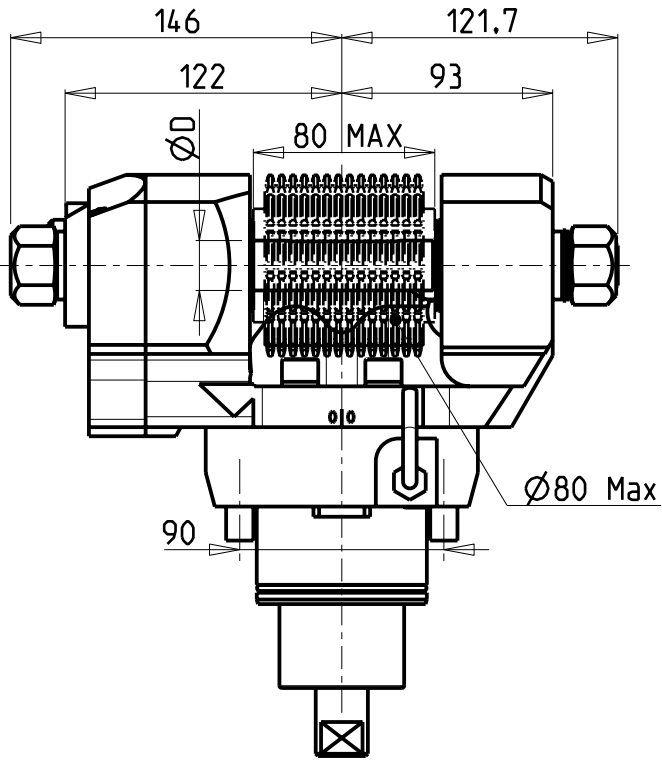

INCLINAZIONE
REGOLABILE ±30°

DOTAZIONI - SUPPLIED WITH - AUSSTATTUNG

- N°1 ALBERO + DISTANZIALI
- N°1 SHAFT + SPACER
- N°1 DORN + ABSTANDSSTUECK

PER ALBERI E DISTANZIALI VEDI PAG. TBL250-1-00
FOR SHAFT END SPACER SEE PAGE TBL250-1-00
FUER DORN UND ABSTANDSSTUECK SEITE TBL250-1-00

Cod. MT	I	RPM	Coppia Max Max Torque Max Drehmoment	Reversibile lato mandrino/contromandrino Reversible sub/main spindle side Umkehrbare Spindel-seite/ Gegenspindel-seite	Lubrificazione est. Ext. coolant Aussenkuehlung	D (mm)	D (Inch)	CHIAVI INCLUSE Keys included Schlüssel inbegriffen		
				X				X	CHUB30	CHE8L08
DW 00251100	1:1	6000	90Nm	X	X	16-22-27-32	3/4"-1"-1 1/4"	CHUB30	CHE8L08	CHUB24 (Ø16 / Ø3/4")
DW 00252100	2:1	3000	110Nm	X	X	16-22-27-32	3/4"-1"-1 1/4"	CHUB30	CHE8L08	CHUB24 (Ø16 / Ø3/4")

HYUNDAI-KIA (WIA)
MOD: SKT400M (L400MA) (LV500RM/LM - LV800RM/LM)

MODULO MOTORIZZATO PORTACREATORE MAGGIORATO
Reinforced driven gear hobber
Angetriebenes Zahnradwaelzfraes-Werkzeug vergroessert

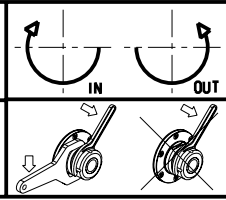

M.T. srl
Via Casino Albini 480
Tel. 0541/956034-957884
Fax 0541/956341
47842 S. GIOVANNI IN M. (RN)
e-mail: mtma@mtmarchetti.com
http://www.mtmarchetti.com

PRODUZIONE MODULI ROTANTI

PAGINA KIA340-4-60

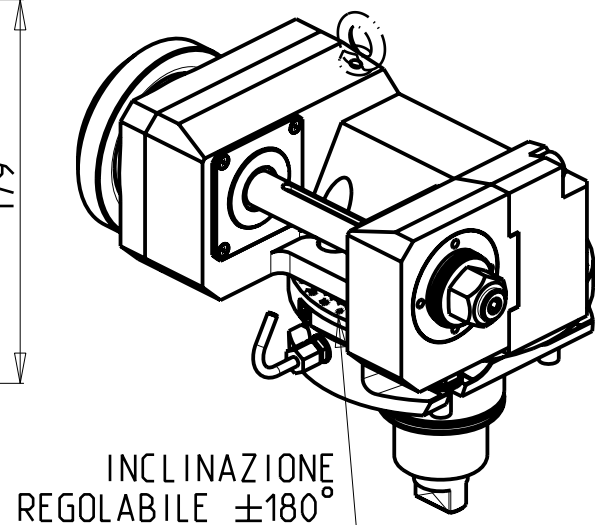
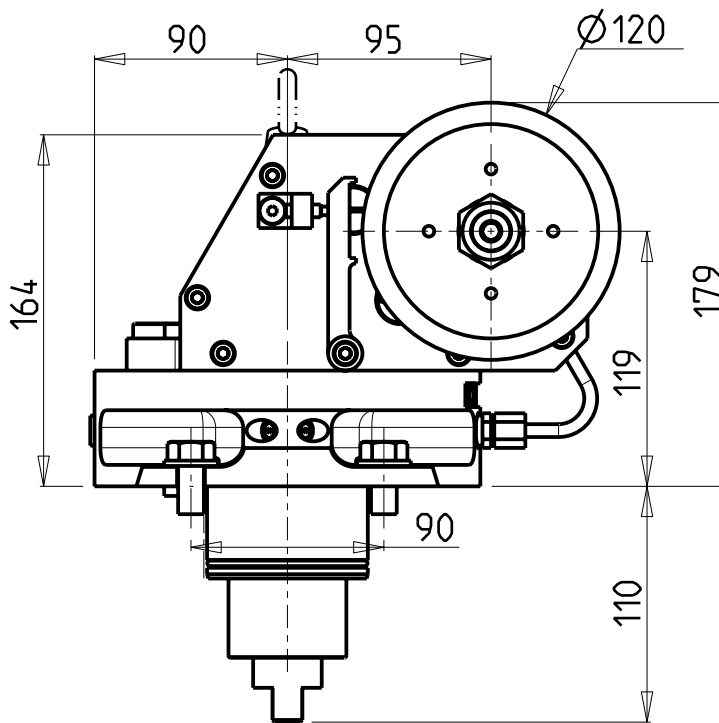
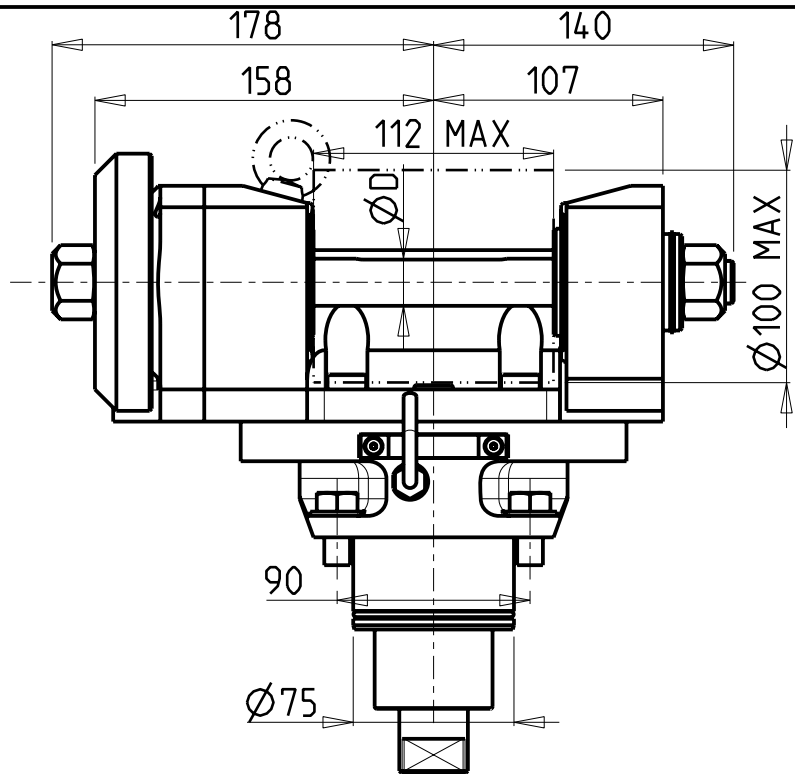

DOTAZIONI - SUPPLIED WITH - AUSSTATTUNG

mm / inch

- N°1 ALBERO + DISTANZIALI
- N°1 SHAFT + SPACER
- N°1 DORN + ABSTANDSSTUECK

PER ALBERI E DISTANZIALI VEDI PAG. TBL250-1-00
 FOR SHAFT END SPACER SEE PAGE TBL250-1-00
 FUER DORN UND ABSTANDSSTUECK SEITE TBL250-1-00

ATTENZIONE - ATTENTION - ACHTUNG

- VERIFICARE LE MISURE DI INGOMBRO PER POSSIBILE INTERFERENZA SU ALCUNI MODELLI DI MACCHINE
- Please check the overall sizes for possible interferences on some machine models
- Bitte überprüfen sie das ausmass um mögliche interferenzen auf einigen maschinen modellen zu vermeiden

Cod. MT	I	RPM MAX	Coppia Max Max Torque Max Drehmoment	Lubrificazione est. Ext. coolant Aussenkuehlung	D (mm)	CHIAVI INCLUSE Keys included Schlüssel inbegriffen				
						CHUB30	CHESL08	CHESL10	CHUB19	
DW0081100	1:1	6000	110Nm	X	22-27-32	CHUB30	CHESL08	CHESL10	CHUB19	NEW
DW00812100	2:1	3000	130Nm	X	22-27-32	CHUB30	CHESL08	CHESL10	CHUB19	NEW

HYUNDAI-KIA (WIA)
 MOD: SKT400M (L400MA) (LV500RM/LM - LV800RM/LM)
 MODULO MOTORIZZATO PORTACREATORE (TAGLIA GRANDE)
 Driven gear hobber (big size)
 Angetriebenes Zahnradwaelzfraes-Werkzeug (grosse version)

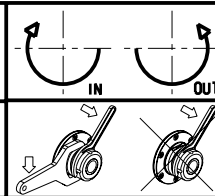

M.T. srl
 Via Casino Albini 480
 Tel. 0541/956034-957884
 Fax 0541/956341
 47842 S. GIOVANNI IN M. (RN)
 e-mail: mtma@mtmarchetti.com
 http://www.mtmarchetti.com

PRODUZIONE MODULI ROTANTI



PAGINA KIA340-4-80

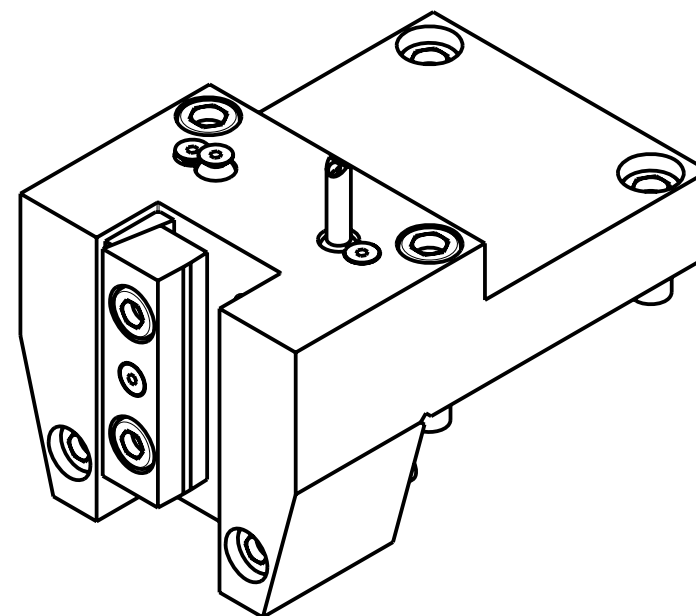
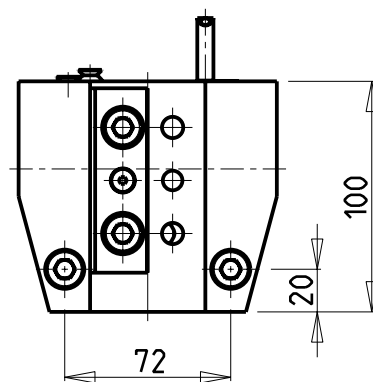
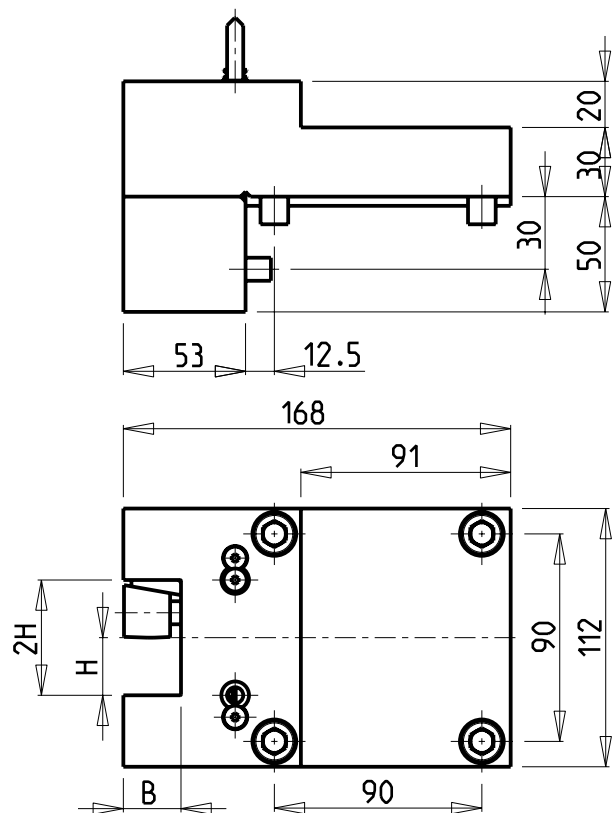

Cod. MT	N°Utensili N°Tools N°Werkzeuge	Misure Dimensions Masse	B	H
0902500	1	mm	25	25
0902540	1	Inch	1"	1"
0903200	1	mm	32	32
0903175	1	Inch	1-1/4"	1-1/4"

HYUNDAI-KIA (WIA)
 MOD: SKT400M (L400MA) (LV500RM/LM - LV800RM/LM)

PORTAUTENSILE RADIALE SINGOLO
 Radial single static tool
 Radial Single-Werkzeughalter

M.T. srl

Via Casino Albini 480
 Tel. 0541/956034-957884
 Fax 0541/956341
 47842 S. GIOVANNI IN M. (RN)
 e-mail: mtma@mtmarchetti.com
 http://www.mtmarchetti.com

PRODUZIONE MODULI ROTANTI



PAGINA KIA423-4-00

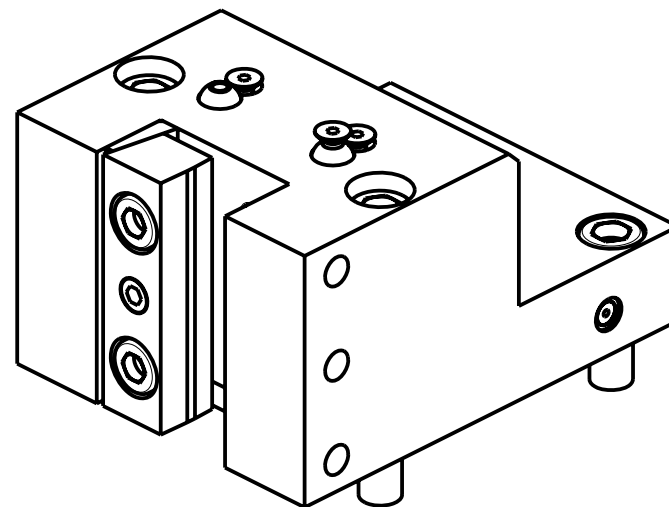
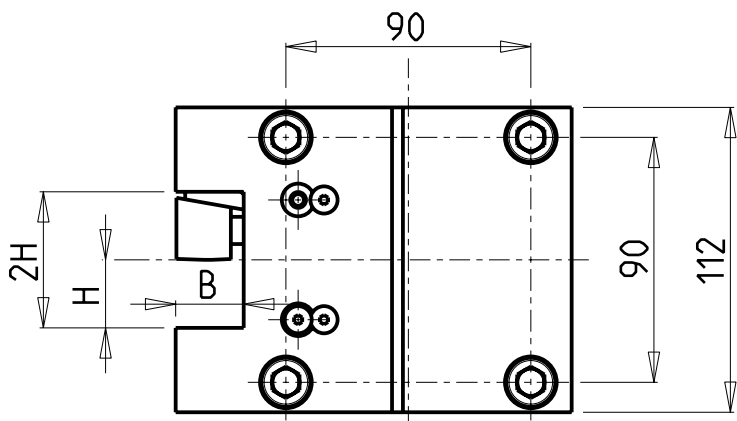
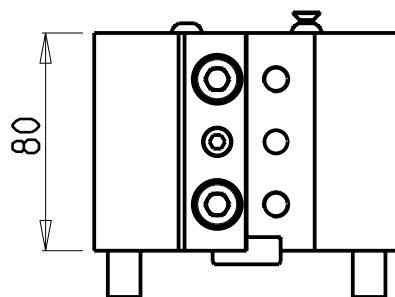
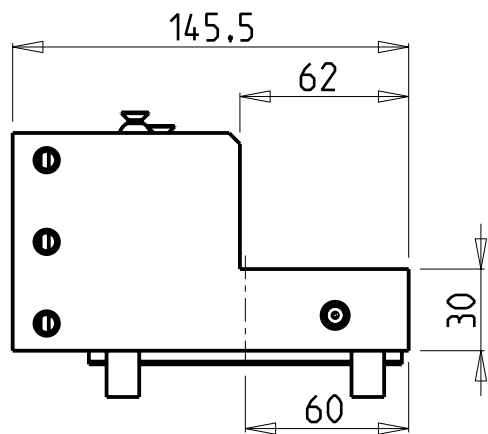

Cod. MT	N°Utensili N°Tools N°Werkzeuge	Reversibile lato mandrino/contromandrino Reversible sub/main spindle side Umkehrbare Spindelseite/ Gegenspindelseite	Misure Dimensions Masse	B	H	
DW 00752500	1	X	mm	25	25	NEW

HYUNDAI-KIA (WIA)
MOD: SKT400M (L400MA) (LV500RM/LM - LV800RM/LM)

PORTAUTENSILE RADIALE SINGOLO
Radial single static tool
Radial Single-Werkzeughalter

M.T. srl

Via Casino Albini 480
Tel. 0541/956034-957884
Fax 0541/956341
47842 S. GIOVANNI IN M. (RN)
e-mail: mtma@mtmarchetti.com
http://www.mtmarchetti.com

PRODUZIONE MODULI ROTANTI



PAGINA KIA423-4-01

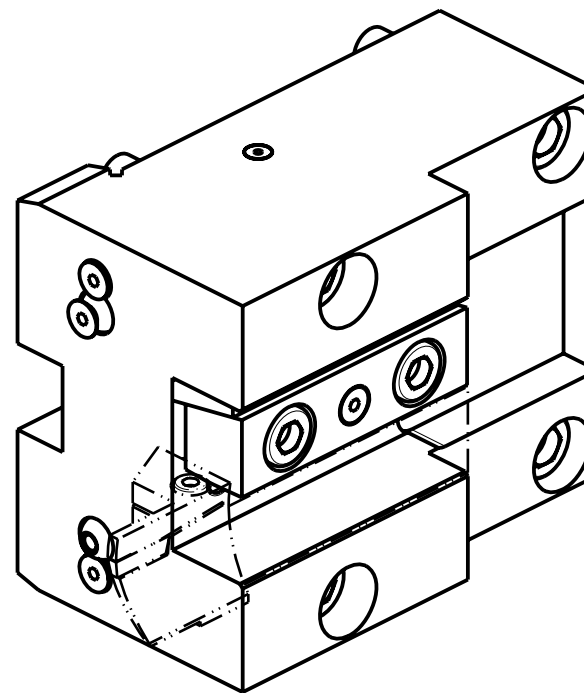
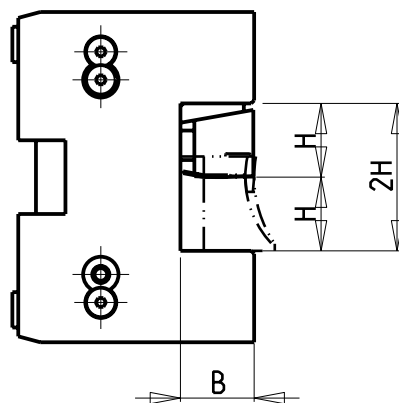
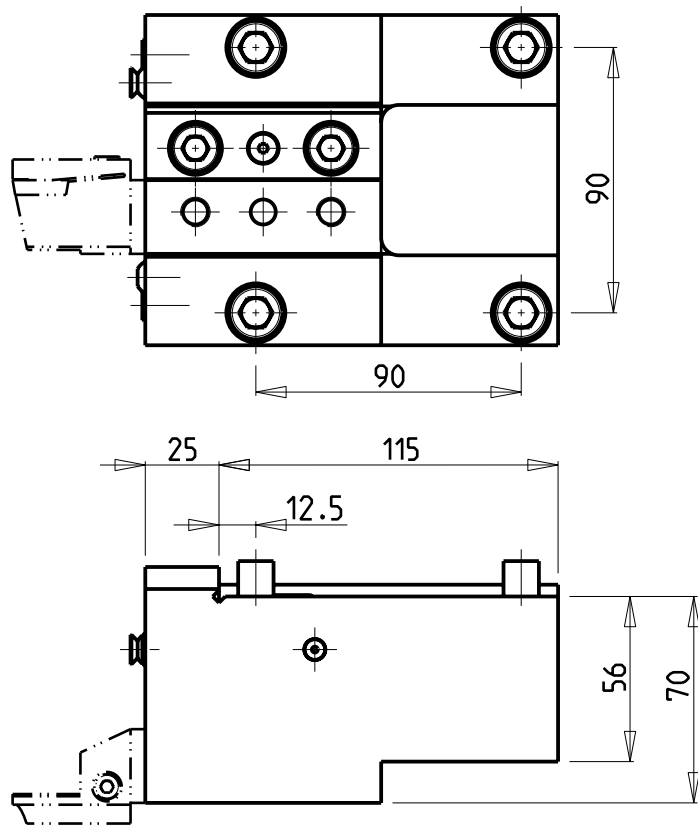

Cod. MT	N°Utensili N°Tools N°Werkzeuge	Reversibile lato mandrino/controlmandrino Reversible sub/main spindle side Umkehrbare Spindel-seite/ Gegenspindel-seite	Misure Dimensions Masse	B	H
0912500	1	X	mm	25	25
0912540	1	X	Inch	1"	1"
0913175	1	X	Inch	1-1/4"	1-1/4"
0913200	1	X	mm	32	32

HYUNDAI-KIA (WIA)
MOD: SKT400M (L400MA) (LV500RM/LM - LV800RM/LM)

PORTAUTENSILE ASSIALE SINGOLO
Axial single static tool
Axial Single-Werkzeughalter

M.T. srl

Via Casino Albini 480
Tel. 0541/956034-957884
Fax 0541/956341
47842 S. GIOVANNI IN M. (RN)
e-mail: mtma@mtmarchetti.com
http://www.mtmarchetti.com

PRODUZIONE MODULI ROTANTI



PAGINA KIA552-4-00

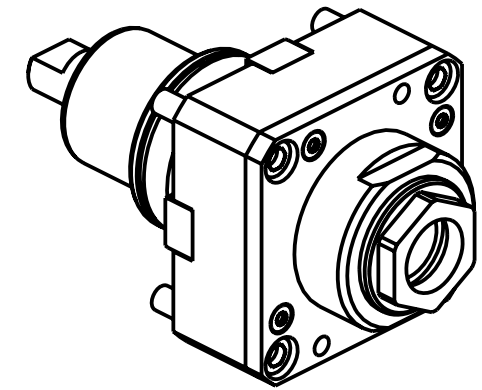
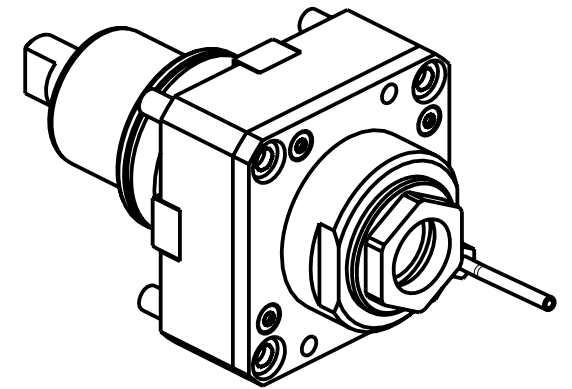
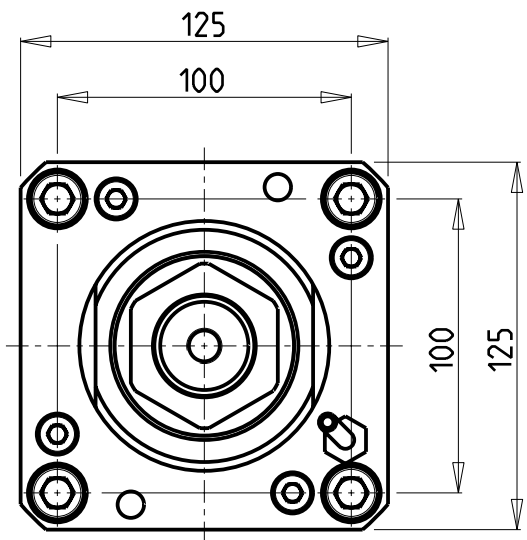
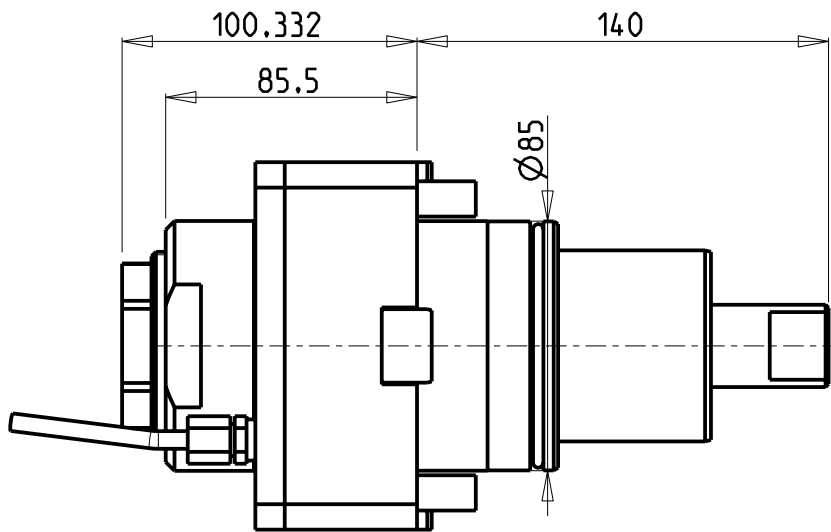

Cod. MT	Mandrino Spindle Spindel	I	RPM	Coppia Max Max Torque Max Drehmoment	Lubrificazione int. Coolant through Innenkuehlung	Lubrificazione est. Ext. coolant Aussenkuehlung	CHIAVI NON INCLUSE Keys not included Schluessel nicht einbegriffen	
DW 00160150	ER A 50	1:1	3000	210Nm		X	CHUB50	CHUB74
DW 00160250	ER A 50	1:1	3000	210Nm	P=30bar	X	CHUB50	CHUB74

HYUNDAI-KIA (WIA)
 MOD: SKT600LM (L600LMA) - SKT700LM (L700LMA) (LV1100RM)

MODULO MOTORIZZATO RADIALE
 Radial driven tool
 Radial angetriebenes Werkzeug

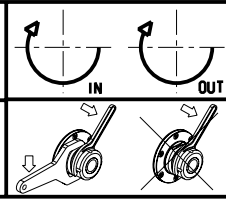

M.T. srl
 Via Casino Albini 480
 Tel. 0541/956034-957884
 Fax 0541/956341
 47842 S. GIOVANNI IN M. (RN)
 e-mail: mtma@mtmarchetti.com
 http://www.mtmarchetti.com

PRODUZIONE MODULI ROTANTI



PAGINA KIA010-5-00

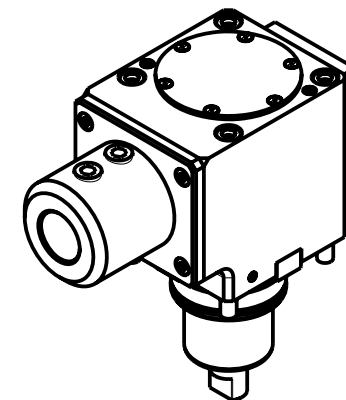
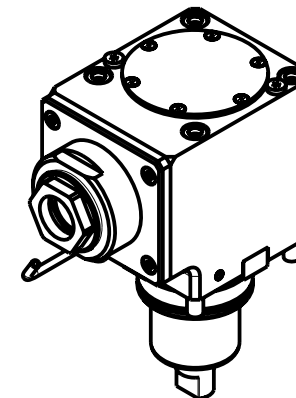
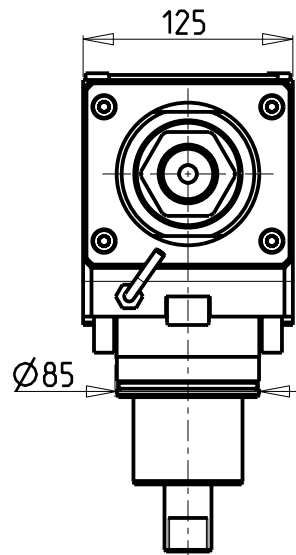
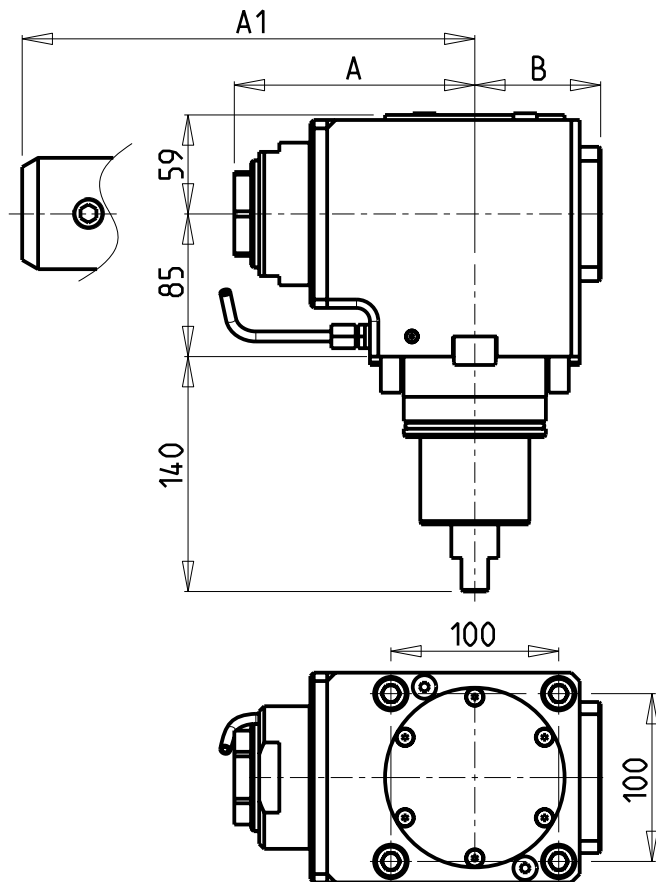

Cod. MT	Mandrino Spindel Spindel	I	RPM	Coppia Max Max Torque Max Drehmoment	Reversibile lato mandrino/controlmandrino Reversible sub/main spindle side Umkehrbare Spindelseite/Gegenspindelseite	Lubr.interna Coolant through Innenkuehlung	Lubr. esterna Ext. coolant Aussenkuehlung	A	A1	B	CHIAVI NON INCLUSE Keys not included Schluessel nicht einbegriffen	
DW 00150150	ER A 50	1:1	3000	210Nm	X		X	143.33	-	75	CHUB50	CHUB74
DW 00150250	ER A 50	1:1	3000	210Nm	X	P=70bar	X	143.33	-	91	CHUB50	CHUB74
DW 00151250	ER A 50	1:1	3000	210Nm	X	P=70bar	X	143.33	-	86	CHUB50	CHUB74
DW 00150140	Weldon 40	1:1	3000	210Nm	X	P=70bar	X	-	175.5	91	-	-

HYUNDAI-KIA (WIA)

MOD: SKT600LM (L600LMA) - SKT700LM (L700LMA)

MODULO MOTORIZZATO ASSIALE H=85mm

Axial driven tool H=85mm

Axial angetriebenes Werkzeug H=85mm

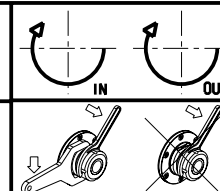

M.T. srl

Via Casino Albini 480
Tel. 0541/956034-957884

Fax 0541/956341

47842 S. GIOVANNI IN M. (RN)

e-mail: mtma@mtmarchetti.com

http://www.mtmarchetti.com

PRODUZIONE MODULI ROTANTI



PAGINA KIA150-5-10

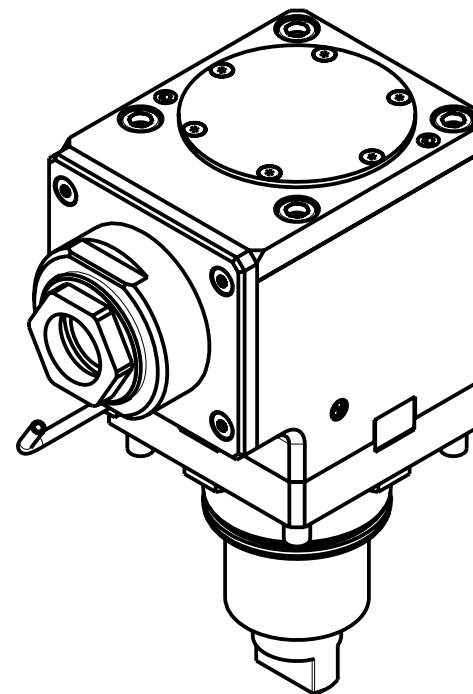
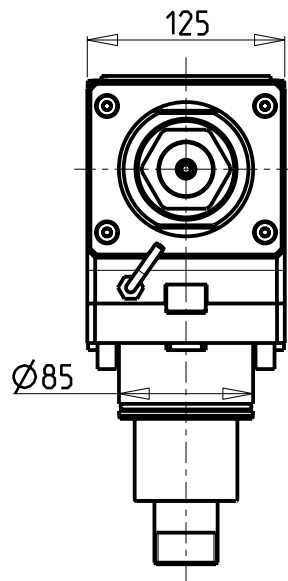
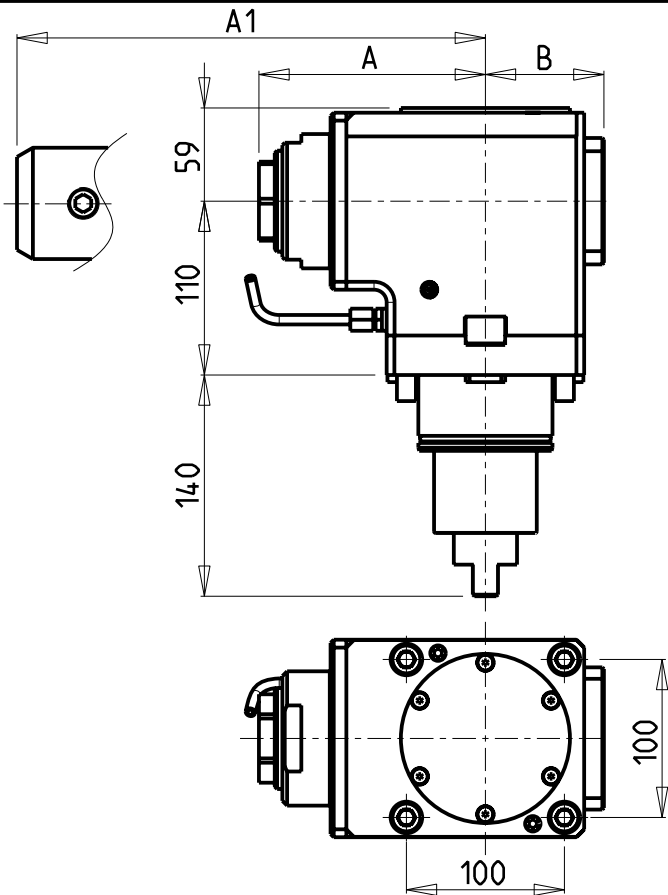

Cod. MT	Mandrino Spindel	I	RPM	Coppia Max Max Torque Max Drehmoment	Reversibile lato mandrino/contromandrino Reversible sub/main spindle side Umkehrbare Spindelseite/ Gegenspindelseite	Lubr.interna Coolant through Innenkuehlung	Lubr. esterna Ext. coolant Aussenkuehlung	A	A1	B	CHIAVI NON INCLUSE Keys not included Schluessel nicht einbegriffen	
DW 01290150	ER A 50	1:1	3000	210Nm	X		X	143.33	-	75	CHUB50	CHUB74
DW 01291250	ER A 50	1:1	3000	210Nm	X	P=70bar	X	143.33	-	86	CHUB50	CHUB74
DW 01290240	Weldon 40	1:1	3000	210Nm	X		X	-	175.5	75	-	-
DW 01290140	Weldon 40	1:1	3000	210Nm	X	P=70bar	X	-	175.5	86	-	-

NEW
NEW
NEW
NEW

HYUNDAI-KIA (WIA)
MOD: SKT600LM (L600LMA) - SKT700LM (L700LMA) (LV1100RM)

MODULO MOTORIZZATO ASSIALE H=110mm
Axial driven tool H=110mm
Axial angetriebenes Werkzeug H=110mm

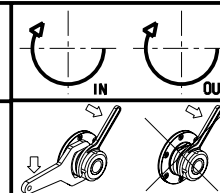

M.T. srl
Via Casino Albini 480
Tel. 0541/956034-957884
Fax 0541/956341
47842 S. GIOVANNI IN M. (RN)
e-mail: mtma@mtmarchetti.com
http://www.mtmarchetti.com

PRODUZIONE MODULI ROTANTI



PAGINA KIA150-5-20

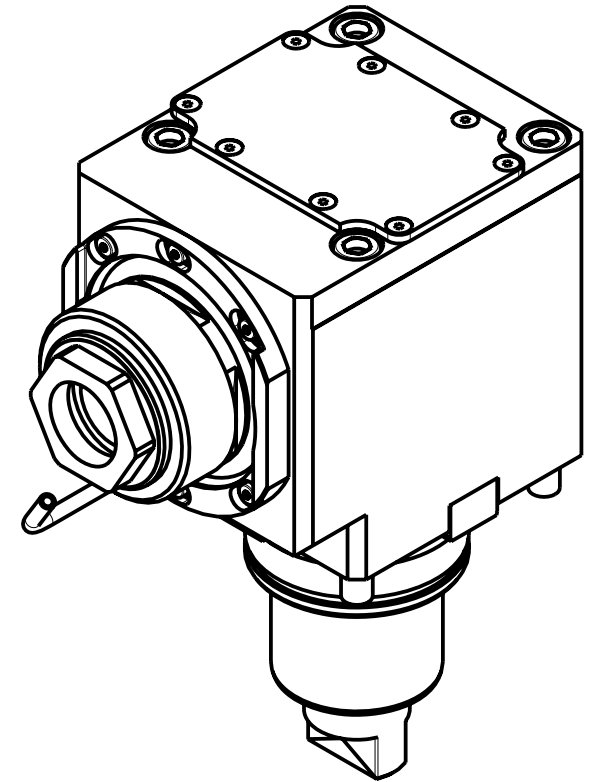
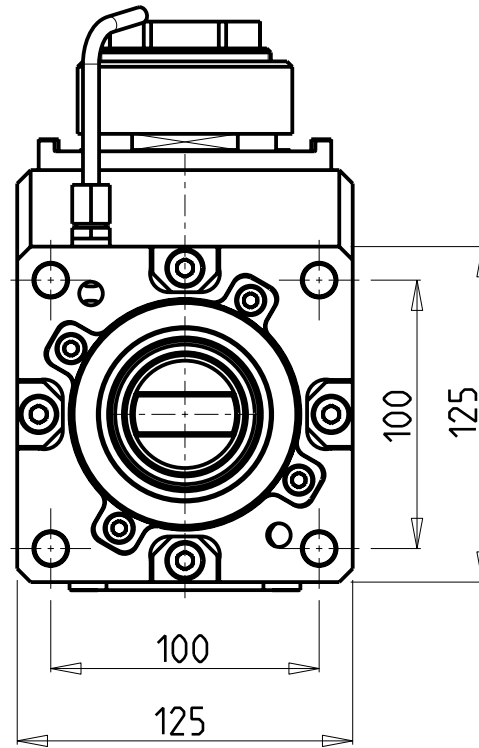
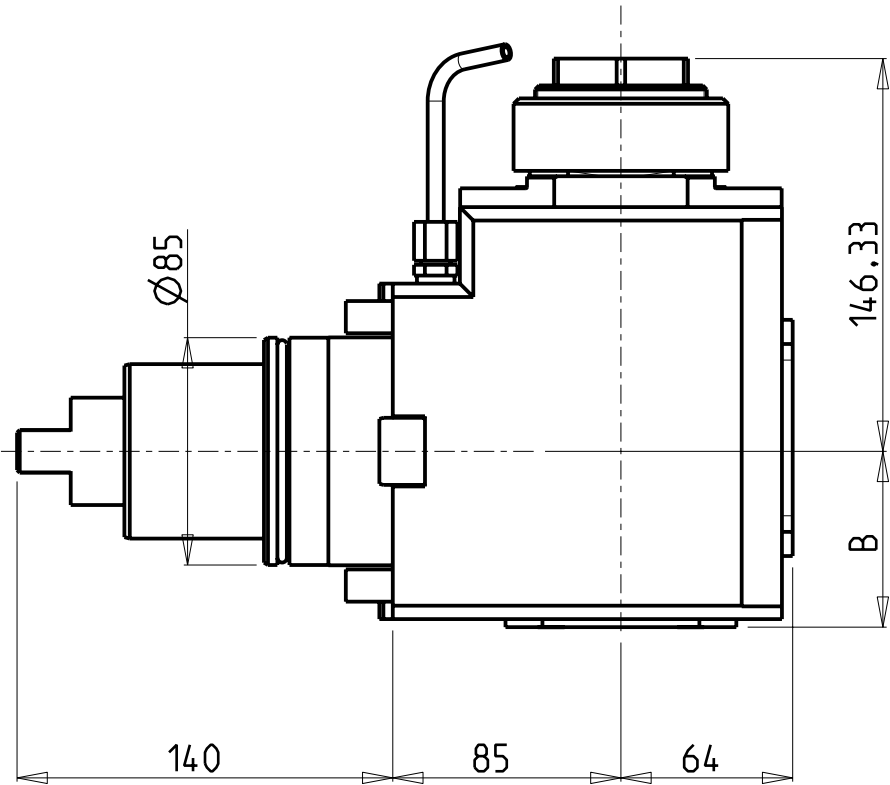

Cod. MT	Mandrino Spindle Spindel	I	RPM	Coppia Max Max Torque Max Drehmoment	Reversibile lato mandrino/contromandrino Reversible sub/main spindle side Umkehrbare Spindel-seite/ Gegenspindel-seite	Lubrificazione int. Coolant through Innenkühlung	Lubrificazione est. Ext. coolant Aussenkühlung	B	CHIAVI NON INCLUSE Keys not included Schlüssel nicht einbegriffen		
DW00460150	ER A 50	2:1	1500	300Nm	X		X	65.5	CHUB50	NZL0010023 •	NEW
DW00460250	ER A 50	2:1	1500	300Nm	X	P=70bar	X	82	CHUB50	NZL0010023 •	NEW

• Chiave inclusa
• Key included
• Schlüssel inbegriffen

HYUNDAI-KIA (WIA)
MOD: SKT600LM (L600LMA) - SKT700LM (L700LMA)

MODULO MOTORIZZATO ASSIALE RIDOTTO I=2:1 H=85mm
Axial geared-down I=2:1 driven tool H=85mm
Axial angetriebenes Werkzeug untersetzt I=2:1 H=85mm

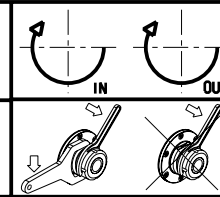

M.T. srl
Via Casino Albini 480
Tel. 0541/956034-957884
Fax 0541/956341
47842 S. GIOVANNI IN M. (RN)
e-mail: mtma@mtmarchetti.com
http://www.mtmarchetti.com

PRODUZIONE MODULI ROTANTI



PAGINA KIA190-5-10

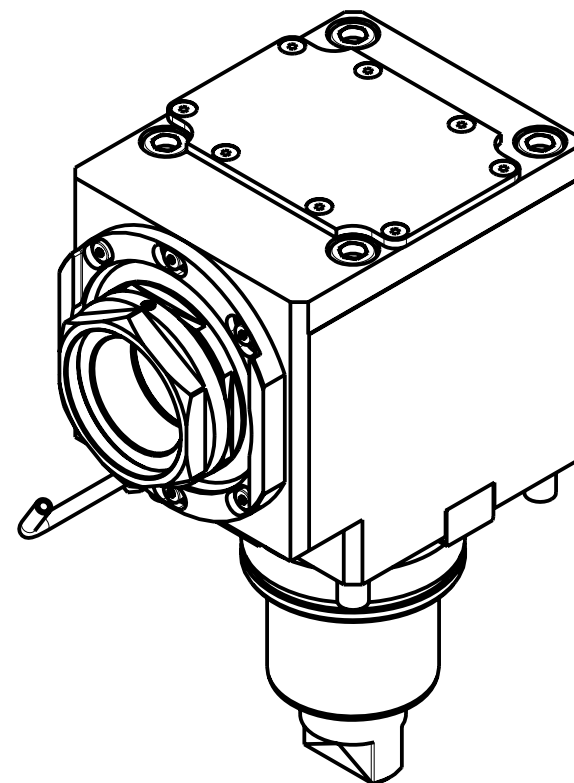
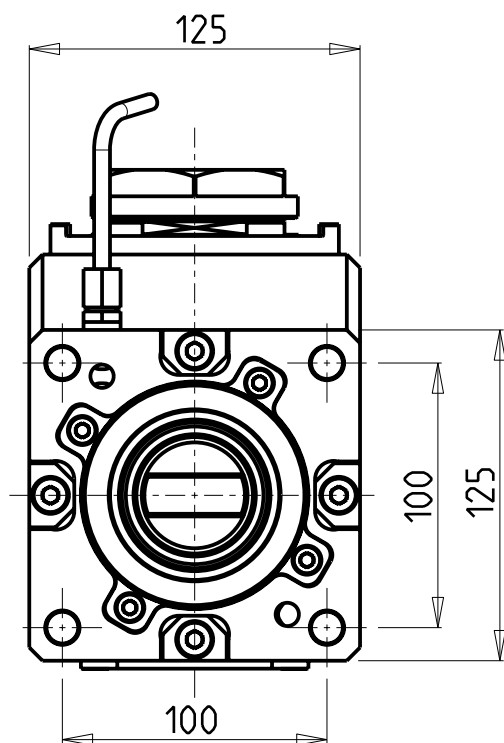
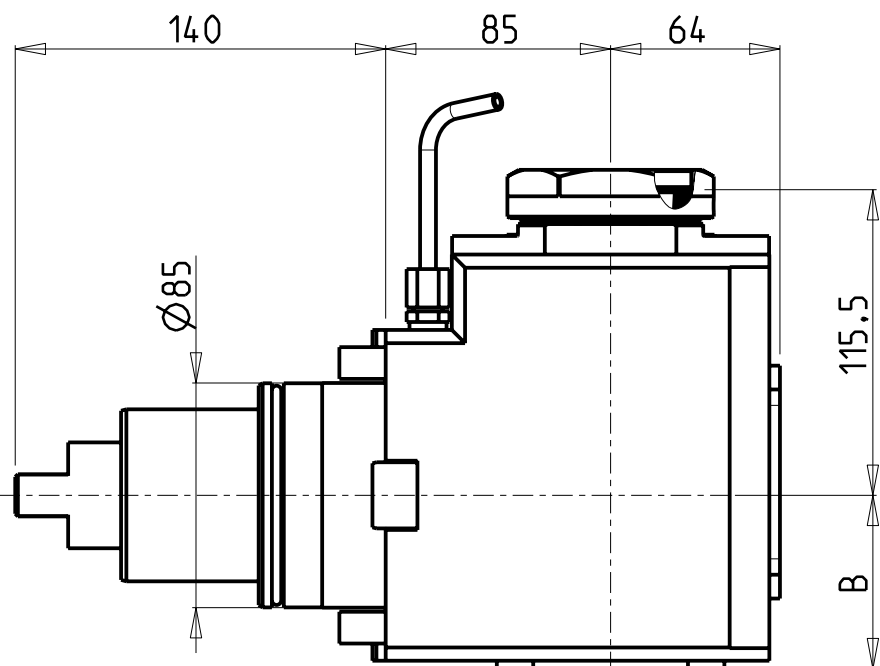

PER PORTAUTENSILI MODULARI MTSK-63 VEDI PAG. TBL300-1-63
 FOR MTSK-63 QUICK CHANGE TOOLHOLDERS CLAMPINGS SEE PAGE TBL300-1-63
 FUER MTSK-63 MODULARE WERKZEUGAUFNAHMEN SIEHE SEITE TBL300-1-63

Cod. MT	Mandrino Spindle Spindel	I	RPM	Coppia Max Max Torque Max Drehmoment	Reversibile lato mandrino/contromandrino Reversible sub/main spindle side Umkehrbare Spindel-seite/ Gegenspindel-seite	Lubrificazione int. Coolant through Innenkühlung	Lubrificazione est. Ext. coolant Aussenkühlung	B	CHIAVI NON INCLUSE Keys not included Schlüssel nicht einbegriffen	
DW00760163	MTSK-63	2:1	1500	300Nm	X		X	65.5	CHUB68	NZL0010023 •
DW00760263	MTSK-63	2:1	1500	300Nm	X	P=70bar	X	82	CHUB68	NZL0010023 •

- Chiave inclusa
- Key included
- Schlüssel inbegriffen

NEW
NEW

HYUNDAI-KIA (WIA)
 MOD: SKT600LM (L600LMA) - SKT700LM (L700LMA)

MODULO MOTORIZZATO ASSIALE MTSK RIDOTTO I=2:1 H=85mm
 Axial MTSK geared-down I=2:1 driven tool H=85mm
 Axial MTSK angetriebenes Werkzeug untersetzt I=2:1 H=85mm

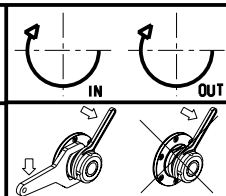

M.T. srl
 Via Casino Albini 480
 Tel. 0541/956034-957884
 Fax 0541/956341
 47842 S. GIOVANNI IN M. (RN)
 e-mail: mtma@mtmarchetti.com
 http://www.mtmarchetti.com

PRODUZIONE MODULI ROTANTI



PAGINA KIA190-5-10-K

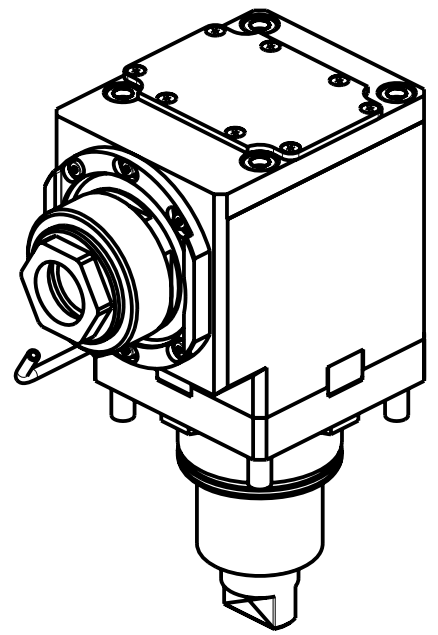
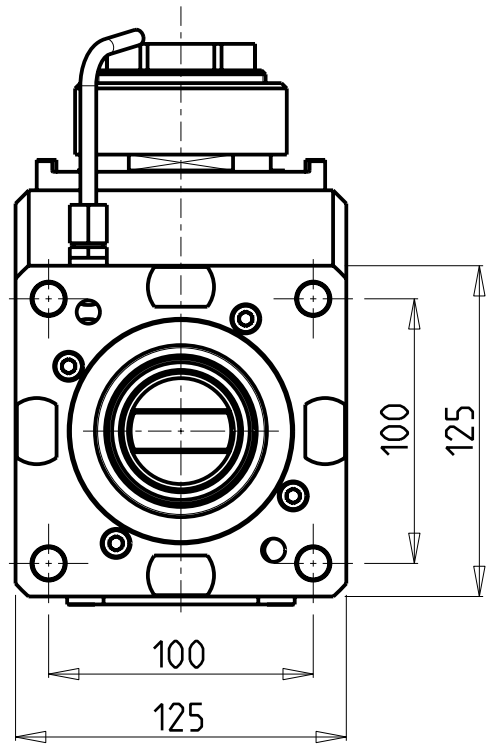
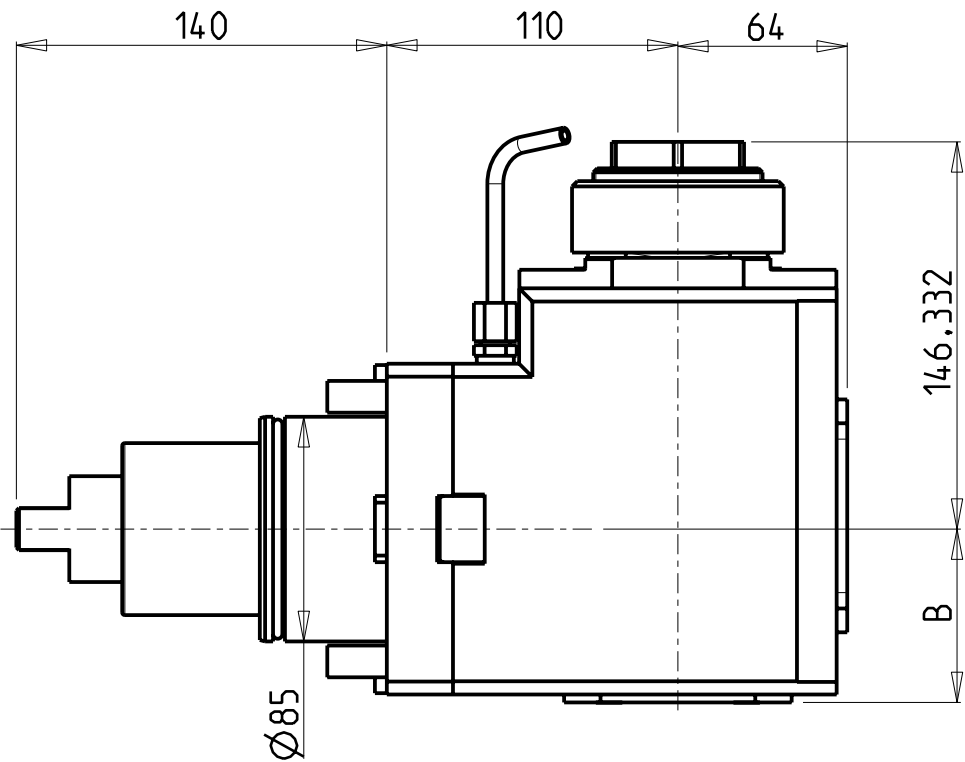

Cod. MT	Mandrino Spindle Spindel	I	RPM	Coppia Max Max Torque Max Drehmoment	Reversibile lato mandrino/contromandrino Reversible sub/main spindle side Umkehrbare Spindel-seite/ Gegen-spindel-seite	Lubrificazione int. Coolant through Innenkühlung	Lubrificazione est. Ext. coolant Aussenkühlung	B	CHIAVI NON INCLUSE Keys not included Schlüssel nicht einbegriffen	
DW 01210150	ER A 50	2:1	1500	300Nm	X		X	65.5	CHUB50	NZL0010023 •
DW 01210250	ER A 50	2:1	1500	300Nm	X	P=70bar	X	82	CHUB50	NZL0010023 •

- Chiave inclusa
- Key included
- Schlüssel inbegriffen

NEW
NEW

HYUNDAI-KIA (WIA)
MOD: SKT600LM (L600LMA) - SKT700LM (L700LMA) (LV1100RM)

MODULO MOTORIZZATO ASSIALE RIDOTTO I=2:1 H=110mm
Axial geared-down I=2:1 driven tool H=110mm
Axial angetriebenes Werkzeug untersetzt I=2:1 H=110mm

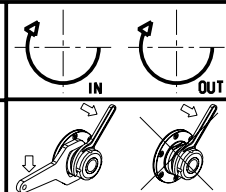

M.T. srl
Via Casino Albini 480
Tel. 0541/956034-957884
Fax 0541/956341
47842 S. GIOVANNI IN M. (RN)
e-mail: mtma@mtmarchetti.com
http://www.mtmarchetti.com

PRODUZIONE MODULI ROTANTI



PAGINA KIA190-5-20

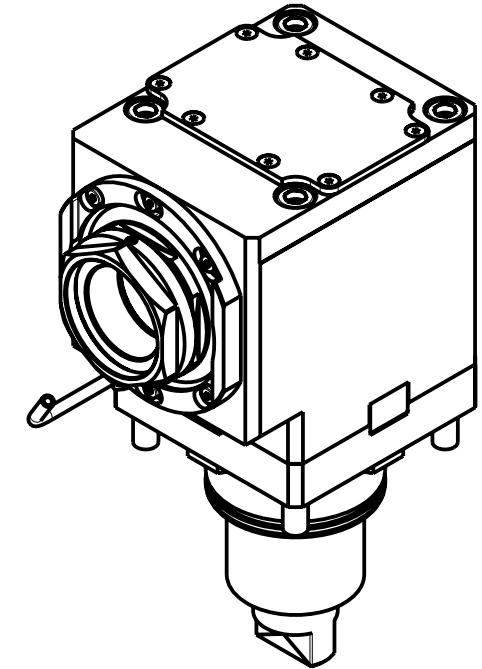
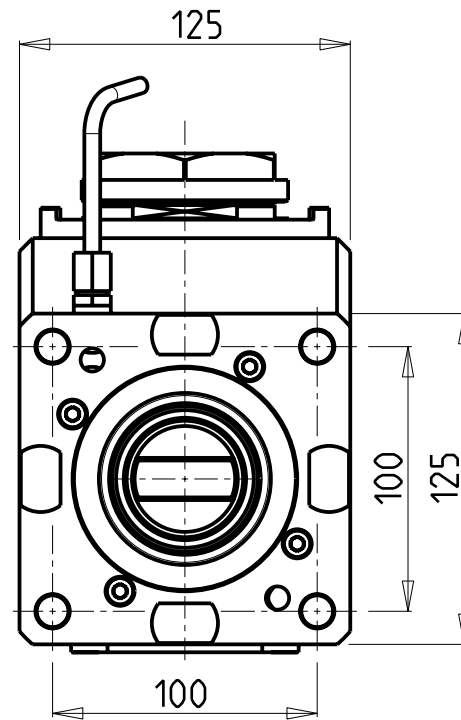
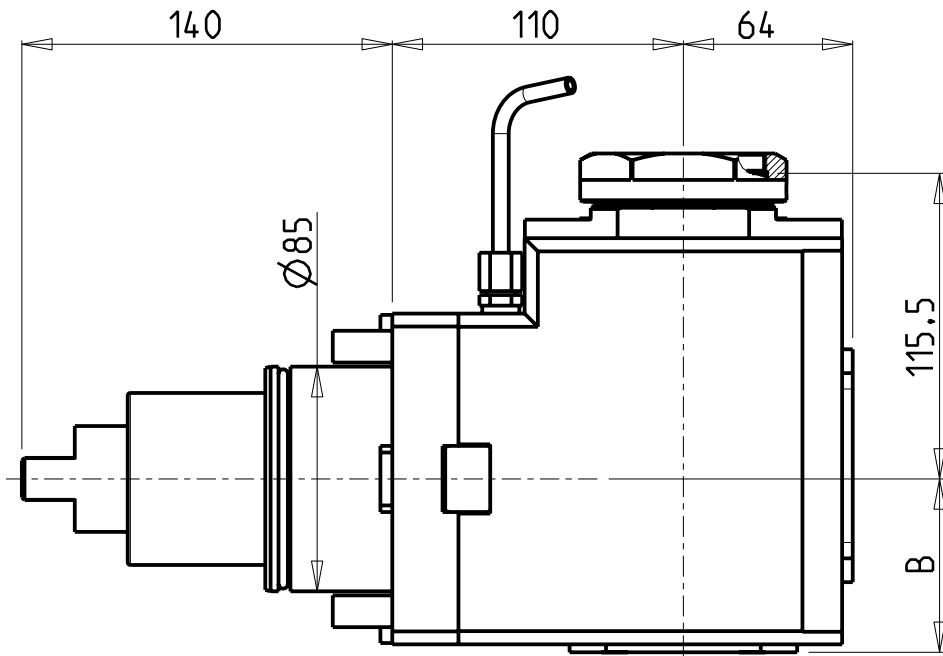

PER PORTAUTENSILI MODULARI MTSK-63 VEDI PAG. TBL300-1-63
 FOR MTSK-63 QUICK CHANGE TOOLHOLDERS CLAMPINGS SEE PAGE TBL300-1-63
 FÜR MTSK-63 MODULARE WERKZEUGAUFNAHMEN SIEHE SEITE TBL300-1-63

Cod. MT	Mandrino Spindle Spindel	I	RPM	Coppia Max Max Torque Max Drehmoment	Reversibile lato mandrino/contromandrino Reversible sub/main spindle side Umkehrbare Spindel-seite/ Gegenspindel-seite	Lubrificazione int. Coolant through Innenkühlung	Lubrificazione est. Ext. coolant Aussenkühlung	B	CHIAVI NON INCLUSE Keys not included Schlüssel nicht einbegriffen	
DW01200163	MTSK-63	2:1	1500	300Nm	X		X	65.5	CHUB68	NZL0010023 •
DW01200263	MTSK-63	2:1	1500	300Nm	X	P=70bar	X	82	CHUB68	NZL0010023 •

NEW
NEW

- Chiave inclusa
- Key included
- Schlüssel inbegriffen

HYUNDAI-KIA (WIA)
 MOD: SKT600LM (L600LMA) - SKT700LM (L700LMA) (LV1100RM)

MODULO MOTORIZZATO ASSIALE MTSK RIDOTTO I=2:1 H=110mm
 Axial MTSK geared-down I=2:1 driven tool H=110mm
 Axial MTSK angetriebenes Werkzeug untersetzt I=2:1 H=110mm

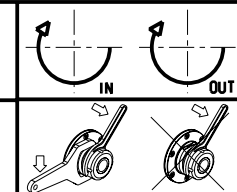

M.T. srl
 Via Casino Albini 480
 Tel. 0541/956034-957884
 Fax 0541/956341
 47842 S. GIOVANNI IN M. (RN)
 e-mail: mtma@mtmarchetti.com
 http://www.mtmarchetti.com

PRODUZIONE MODULI ROTANTI

PAGINA KIA190-5-20-K

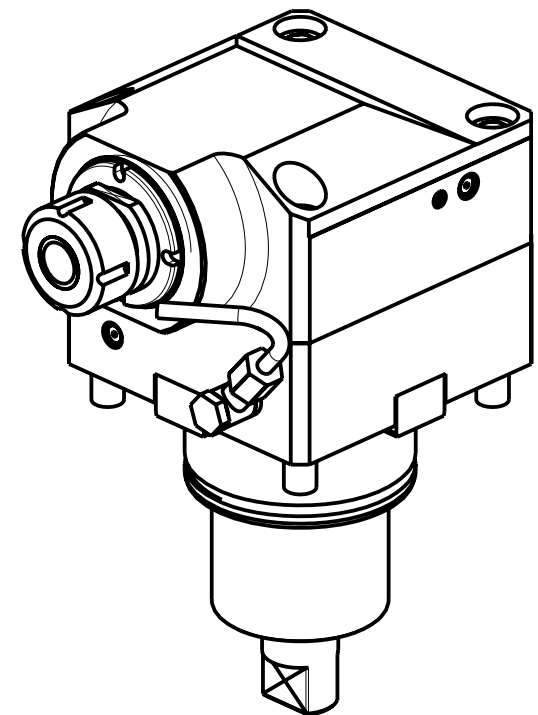
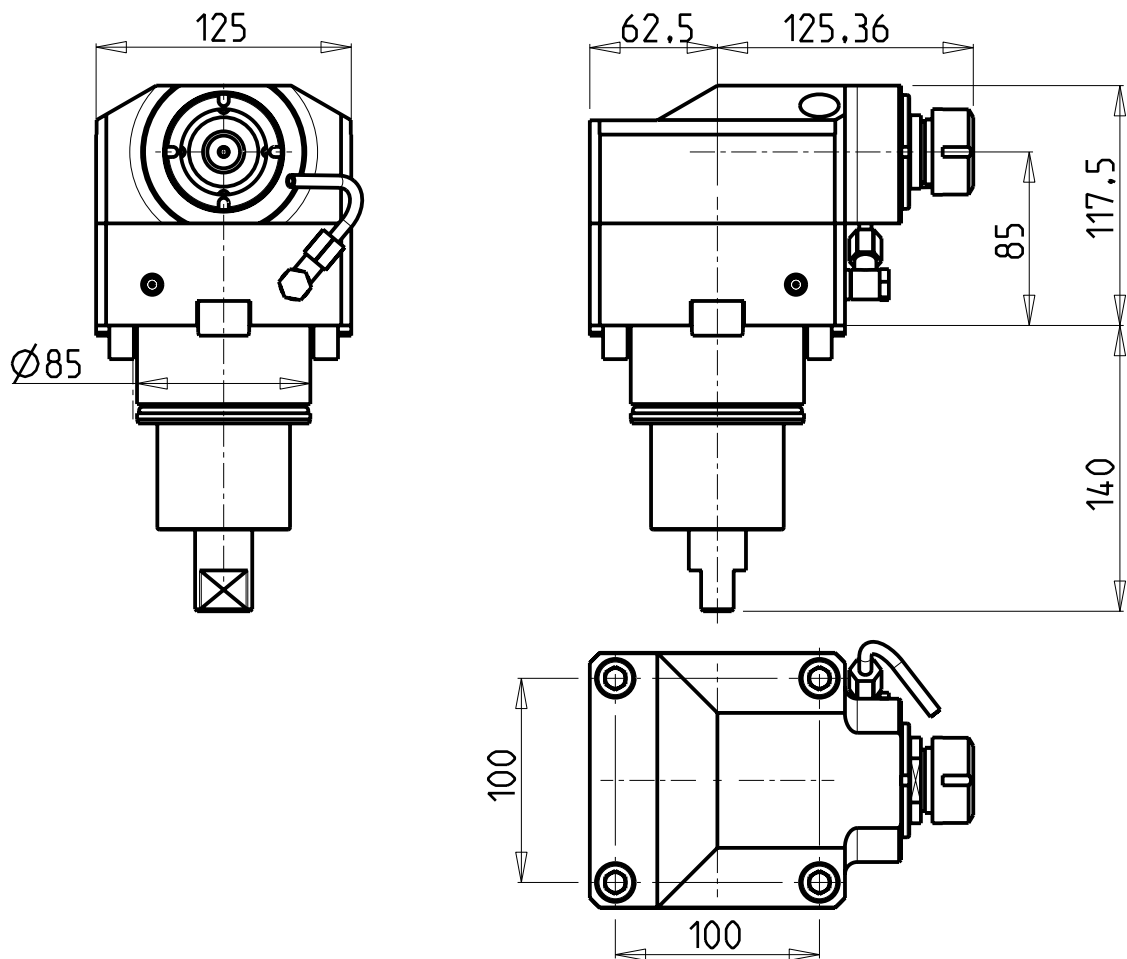

Cod. MT	Mandrino Spindel Spindel	i	RPM MAX	Coppia Max Max Torque Max Drehmoment	Lubrificazione int. Coolant through Innenkuehlung	Lubrificazione est. Ext. coolant Aussenkuehlung	CHIAVI NON INCLUSE Keys not included Schlüssel nicht einbegriffen	
							CHSTER25	CHUB36
DW00580125	ER25	1:3	12000	70Nm		X	CHSTER25	CHUB36
DW00580225	ER25	1:3	12000	70Nm	P=70bar	X	CHSTER25	CHUB36

HYUNDAI-KIA (WIA)
 MOD: SKT600LM (L600LMA) - SKT700LM (L700LMA)
 MODULO MOTORIZZATO ASSIALE MOLTIPLICATO I=1:3
 Axial geared-up I=1:3 driven tool
 Axial angetriebenes Werkzeug uebersetzt I=1:3

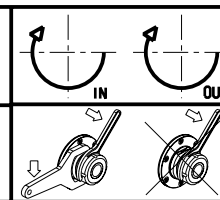

M.T. srl
 Via Casino Albini 480
 Tel. 0541/956034-957884
 Fax 0541/956341
 47842 S. GIOVANNI IN M. (RN)
 e-mail: mtma@mtmarchetti.com
 http://www.mtmarchetti.com

PRODUZIONE MODULI ROTANTI

PAGINA KIA205-5-10

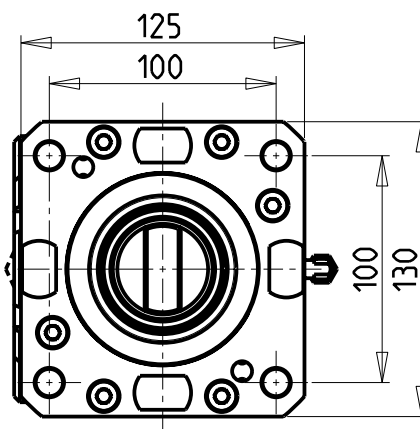
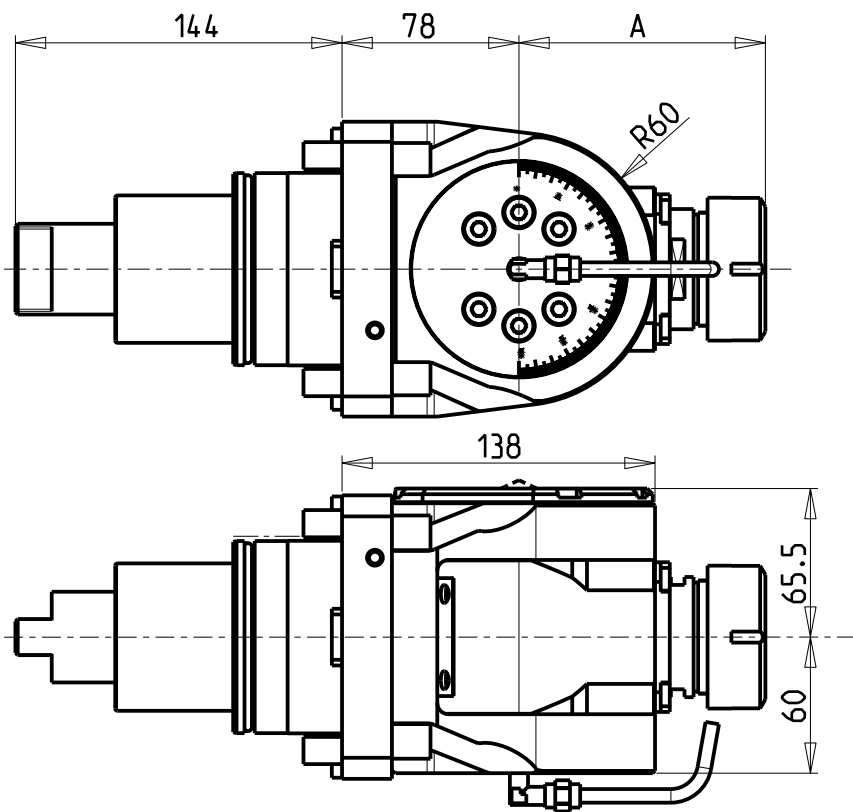

ATTENZIONE - ATTENTION - ACHTUNG

- Su macchine SKT400 (L400MA) non arriva in centro mandrino
- On machines SKT400 (L400MA) tool does not get to the centre of the spindle axis.
- Auf Maschinen SKT400 (L400MA) erreicht das Werkzeug nicht die Mitte der Werkzeug-Achse.

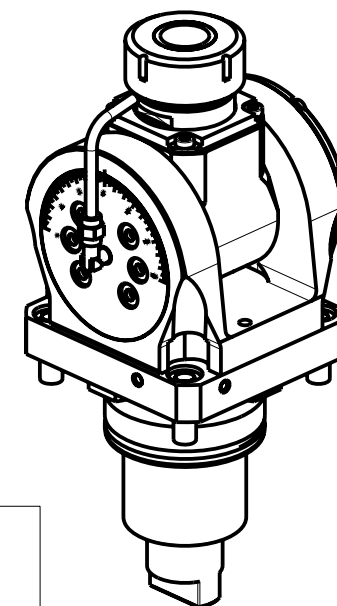

Cod. MT	Mandrino Spindel Spindel	I	RPM	Coppia Max Max Torque Max Drehmoment	Lubrificazione int. Coolant through Innenkuehlung	Lubrificazione est. Ext. coolant Aussenkuehlung	A	CHIAVI INCLUSE Keys included Schluessel inbegriffen					
DW 00830332	ERA32	1:1	3000	50Nm		X	81	CHUB30	CHUB46	CHTAER32ZC	CHESL10	CHESL06	NEW
DW 00830432	ERA32	1:1	3000	50Nm	P=70bar	X	81	CHUB30	CHUB46	CHTAER32ZC	CHESL10	CHESL06	NEW
DW 00830140	ER40	1:1	3000	50Nm		X	108.66	-	CHUB46	CHSTER40	CHESL10	CHESL06	NEW
DW 00830240	ER40	1:1	3000	50Nm	P=70bar	X	108.66	-	CHUB46	CHSTER40	CHESL10	CHESL06	NEW

HYUNDAI-KIA (WIA)
 MOD: SKT600LM (L600LMA) - SKT700LM (L700LMA) (LV1100RM)

MODULO MOTORIZZATO ORIENTABILE +/-90°
 +/-90° adjustable angle driven tool
 Angetriebenes Werkzeug schwenkbar +/-90°

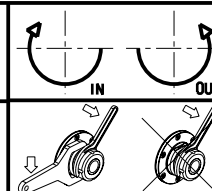

M.T. srl
 Via Casino Albini 480
 Tel. 0541/956034-957884
 Fax 0541/956341
 47842 S. GIOVANNI IN M. (RN)
 e-mail: mtma@mtmarchetti.com
 http://www.mtmarchetti.com

PRODUZIONE MODULI ROTANTI



PAGINA KIA339-5-00

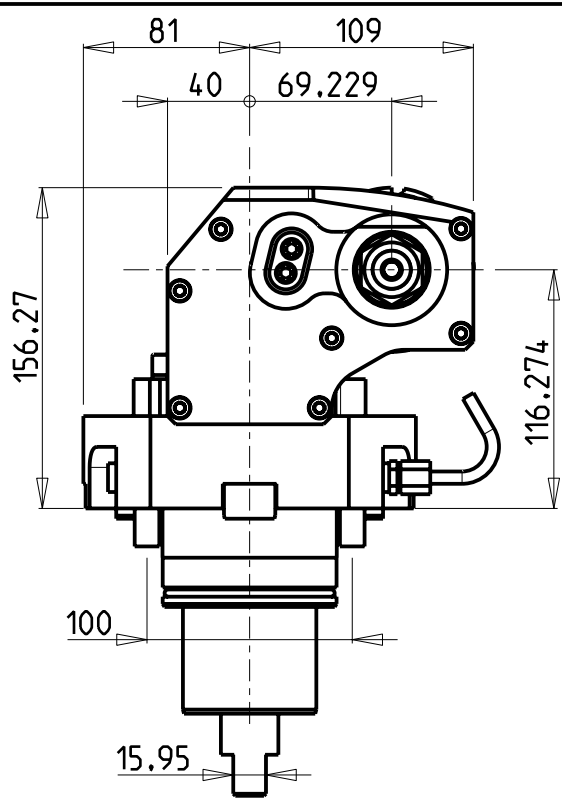
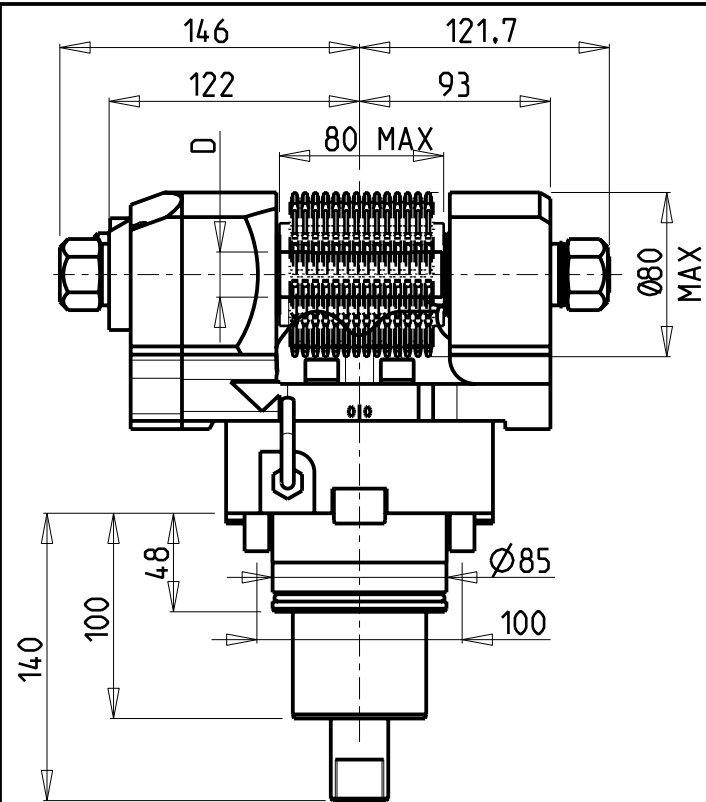

INCLINAZIONE
REGOLABILE ±30°

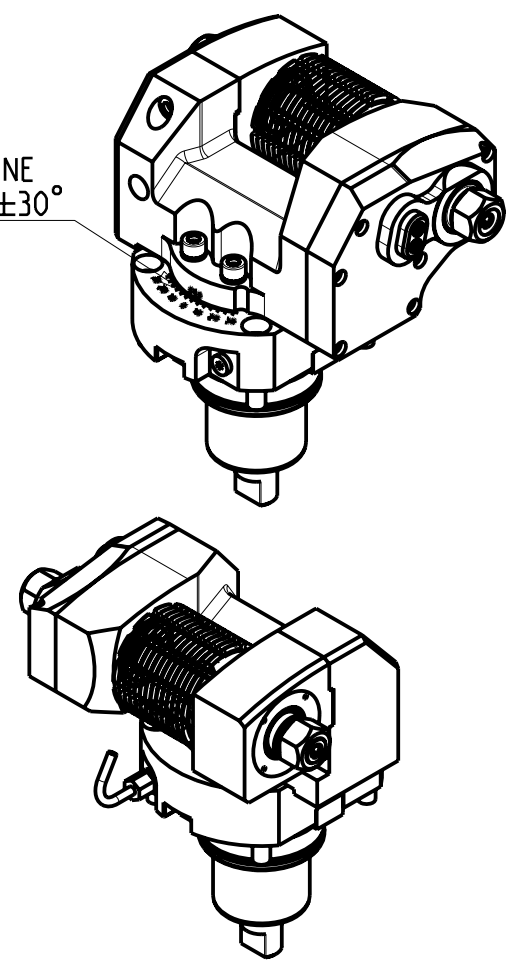

DOTAZIONI - SUPPLIED WITH - AUSSTATTUNG

- | mm / inch | - N°1 ALBERO + DISTANZIALI |
|-----------|-----------------------------|
| | - N°1 SHAFT + SPACER |
| | - N°1 DORN + ABSTANDSSTUECK |

PER ALBERI E DISTANZIALI VEDI PAG. TBL250-1-00
FOR SHAFT END SPACER SEE PAGE TBL250-1-00
FUER DORN UND ABSTANDSSTUECK SEITE TBL250-1-00

Cod. MT	i	RPM max	Coppia Max Max Torque Max Drehmoment	Lubrificazione est. Ext. coolant Aussenkuehlung	D (mm)	D (Inch)	CHIAVI INCLUSE Keys included Schlüssel inbegriffen			
							CHUB30	CHESL08	CHESL10	CHUB24 (Ø16 / Ø3/4")
DW 00181100	1:1	3000	90Nm	X	16-22-27-32	3/4"-1"-1 1/4"	CHUB30	CHESL08	CHESL10	CHUB24 (Ø16 / Ø3/4")
DW 00182100	2:1	1500	110Nm	X	16-22-27-32	3/4"-1"-1 1/4"	CHUB30	CHESL08	CHESL10	CHUB24 (Ø16 / Ø3/4")

HYUNDAI-KIA (WIA)
MOD: SKT600LM (L600LMA) - SKT700LM (L700LMA) (LV1100RM)

MODULO MOTORIZZATO PORTACREATORE MAGGIORATO
Reinforced driven gear hobber
Angetriebenes Zahnradwaelzfraes-Werkzeug vergroessert

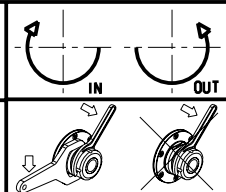

M.T. srl
Via Casino Albini 480
Tel. 0541/956034-957884
Fax 0541/956341
47842 S. GIOVANNI IN M. (RN)
e-mail: mtma@mtmarchetti.com
http://www.mtmarchetti.com

PRODUZIONE MODULI ROTANTI

PAGINA KIA340-5-60

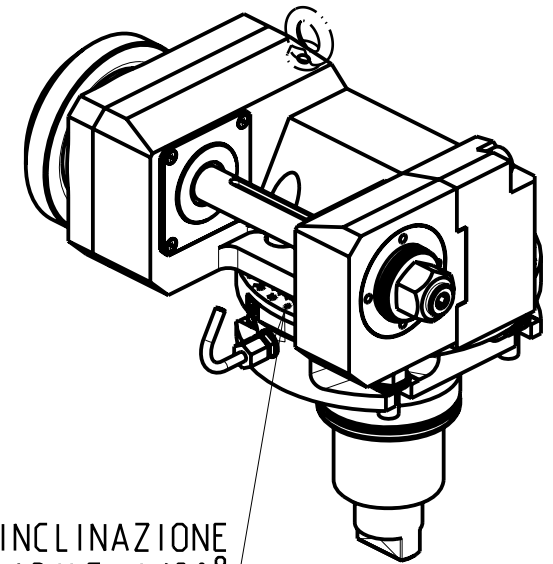
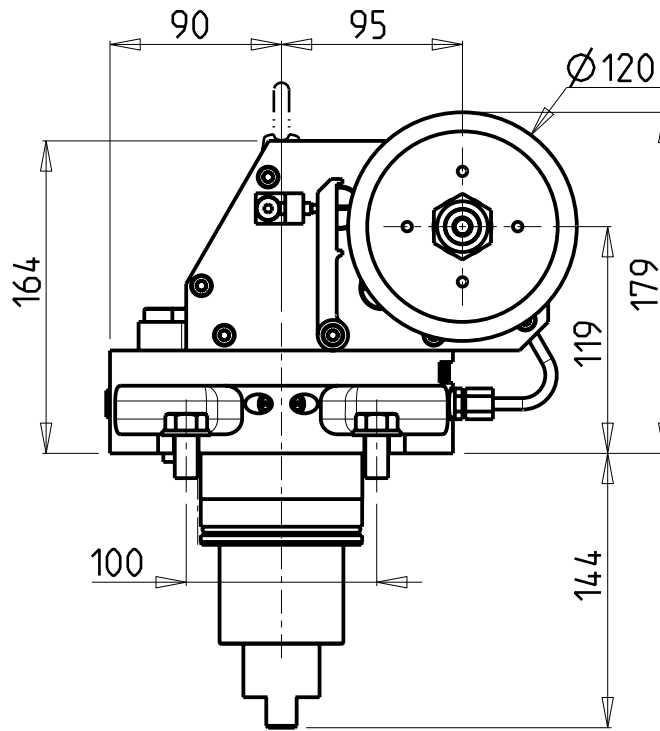
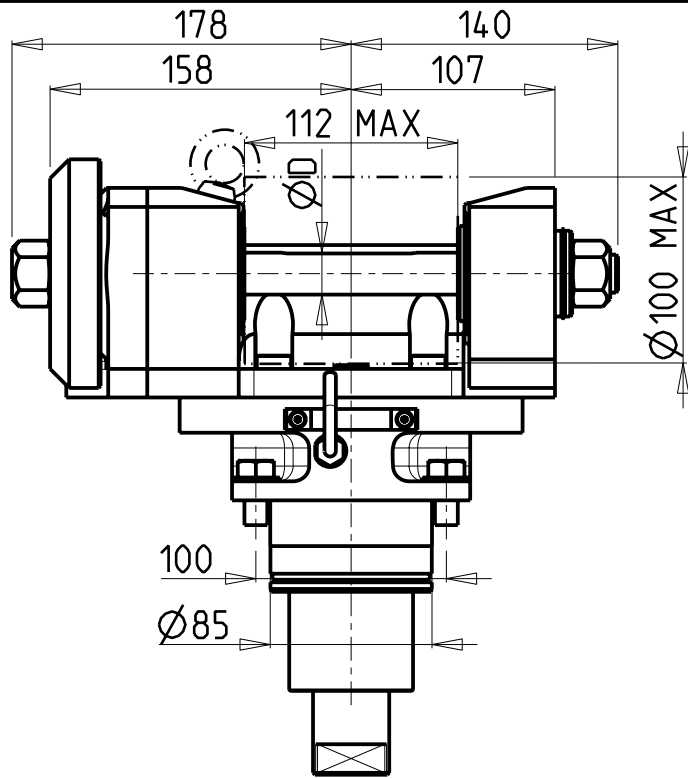

INCLINAZIONE
REGOLABILE $\pm 180^\circ$

DOTAZIONI - SUPPLIED WITH - AUSSTATTUNG

mm / inch

- N°1 ALBERO + DISTANZIALI
- N°1 SHAFT + SPACER
- N°1 DORN + ABSTANDSSTUECK

PER ALBERI E DISTANZIALI VEDI PAG. TBL250-1-00
FOR SHAFT END SPACER SEE PAGE TBL250-1-00
FUER DORN UND ABSTANDSSTUECK SEITE TBL250-1-00

Cod. MT	I	RPM MAX	Coppia Max Max Torque Max Drehmoment	Lubrificazione est. Ext. coolant Aussenkuehlung	D (mm)	CHIAVI INCLUSE Keys included Schlüssel inbegriffen				
						CHUB30	CHESL08	CHESL10	CHUB19	
DW00851100	1:1	3000	110Nm	X	22-27-32	CHUB30	CHESL08	CHESL10	CHUB19	NEW
DW00852100	2:1	1500	130Nm	X	22-27-32	CHUB30	CHESL08	CHESL10	CHUB19	NEW

HYUNDAI-KIA (WIA)
MOD: SKT600LM (L600LMA) - SKT700LM (L700LMA) (LV1100RM)

MODULO MOTORIZZATO PORTACREATORE (TAGLIA GRANDE)
Driven gear hobber (big size)
Angetriebenes Zahnradwaelzfraes-Werkzeug (grosse version)

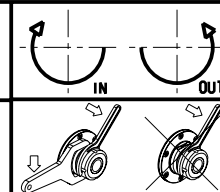

M.T. srl

Via Casino Albini 480
Tel. 0541/956034-957884
Fax 0541/956341

47842 S. GIOVANNI IN M. (RN)
e-mail: mtma@mtmarchetti.com
http://www.mtmarchetti.com

PRODUZIONE MODULI ROTANTI



PAGINA KIA340-5-80

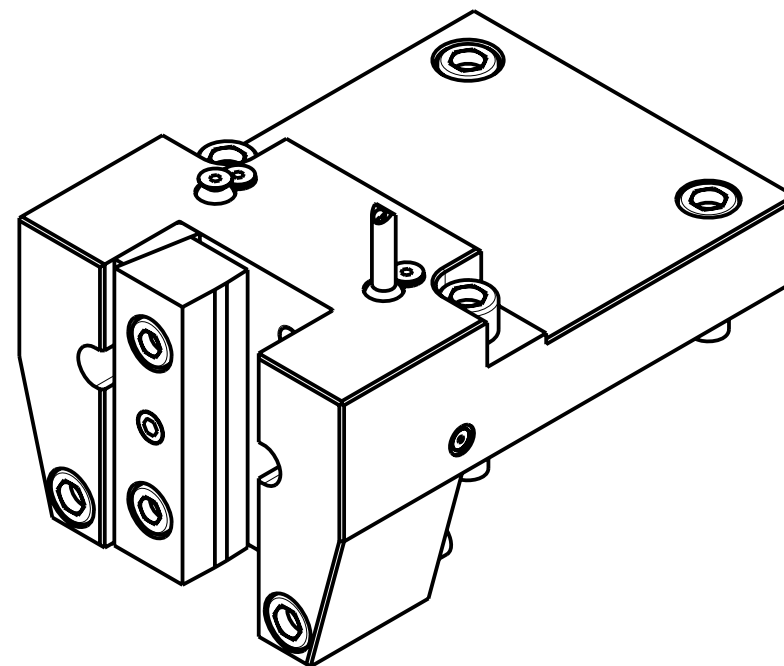
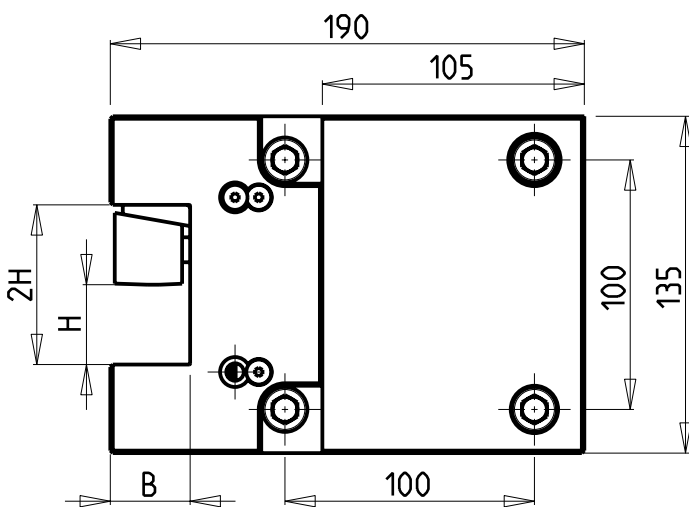
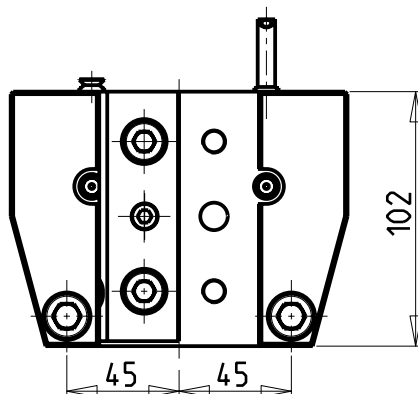
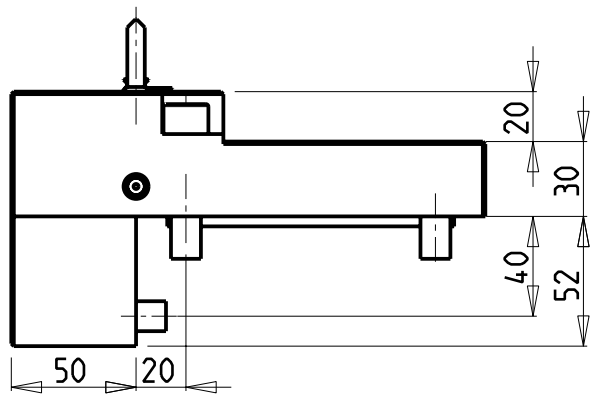

Cod. MT	N°Utensili N°Tools N°Werkzeuge	Misure Dimensions Masse	B	H
DW00323200	1	mm	32	32
DW00323175	1	Inch	1-1/4"	1-1/4"

HYUNDAI-KIA (WIA)
 MOD: SKT600LM (L600LMA) - SKT700LM (L700LMA) (LV1100RM)

PORTAUTENSILE RADIALE SINGOLO
 Radial single static tool
 Radial Single-Werkzeughalter

M.T. srl

Via Casino Albini 480
 Tel. 0541/956034-957884
 Fax 0541/956341
 47842 S. GIOVANNI IN M. (RN)
 e-mail: mtma@mtmarchetti.com
 http://www.mtmarchetti.com

PRODUZIONE MODULI ROTANTI



PAGINA KIA423-5-00

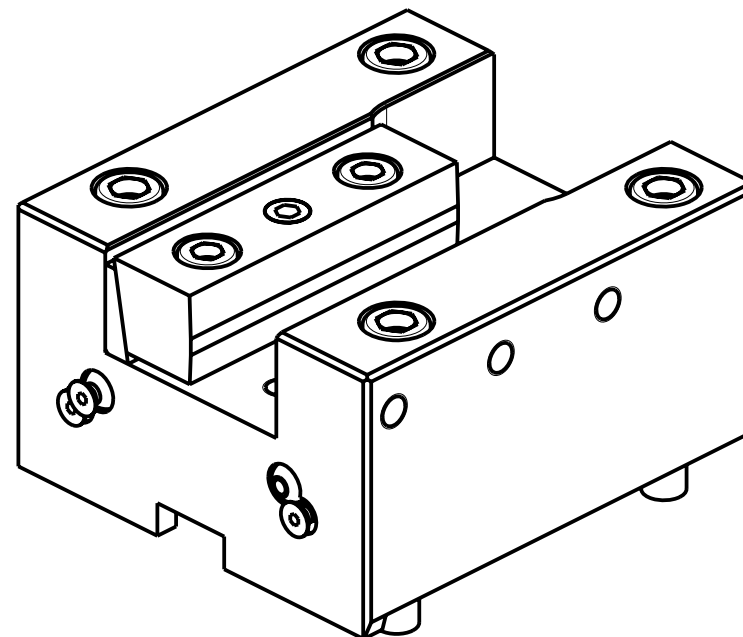
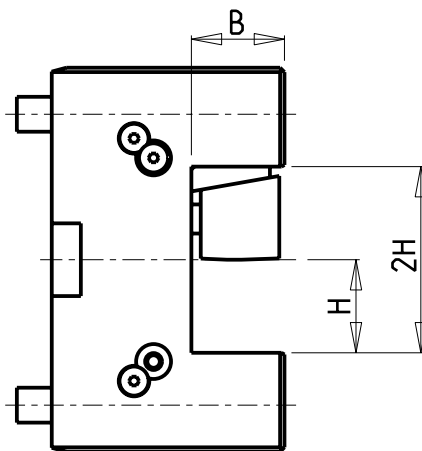
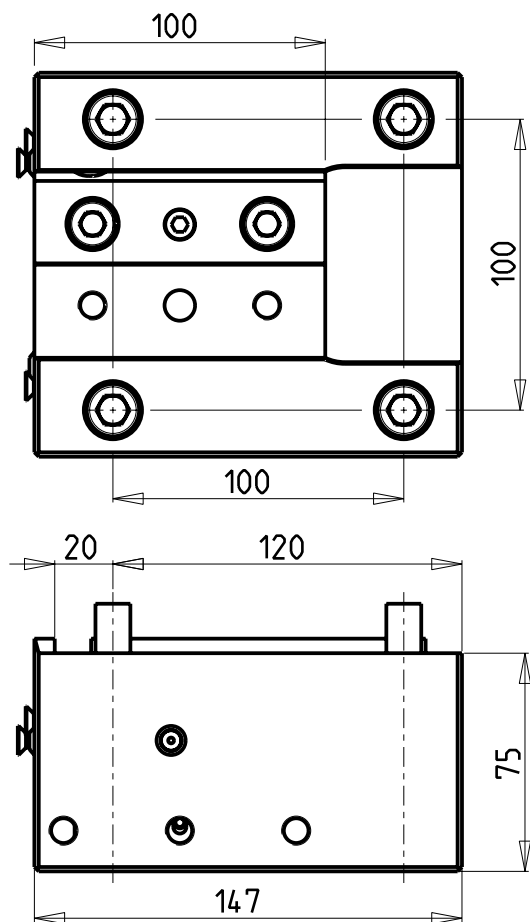

Cod. MT	N°Utensili N°Tools N°Werkzeuge	Reversibile lato mandrino/contromandrino Reversible sub/main spindle side Umkehrbare Spindelseite/ Gegenspindelseite	Misure Dimensions Masse	B	H
DW00333200	1/2	X	mm	32	32
DW00333175	1/2	X	Inch	1-1/4"	1-1/4"

HYUNDAI-KIA (WIA)
MOD: SKT600LM (L600LMA) - SKT700LM (L700LMA) (LV1100RM)

PORTAUTENSILE ASSIALE SINGOLO
Axial single static tool
Axial Single-Werkzeughalter

M.T. srl

Via Casino Albini 480
Tel. 0541/956034-957884
Fax 0541/956341
47842 S. GIOVANNI IN M. (RN)
e-mail: mtma@mtmarchetti.com
http://www.mtmarchetti.com

PRODUZIONE MODULI ROTANTI



PAGINA KIA552-5-00

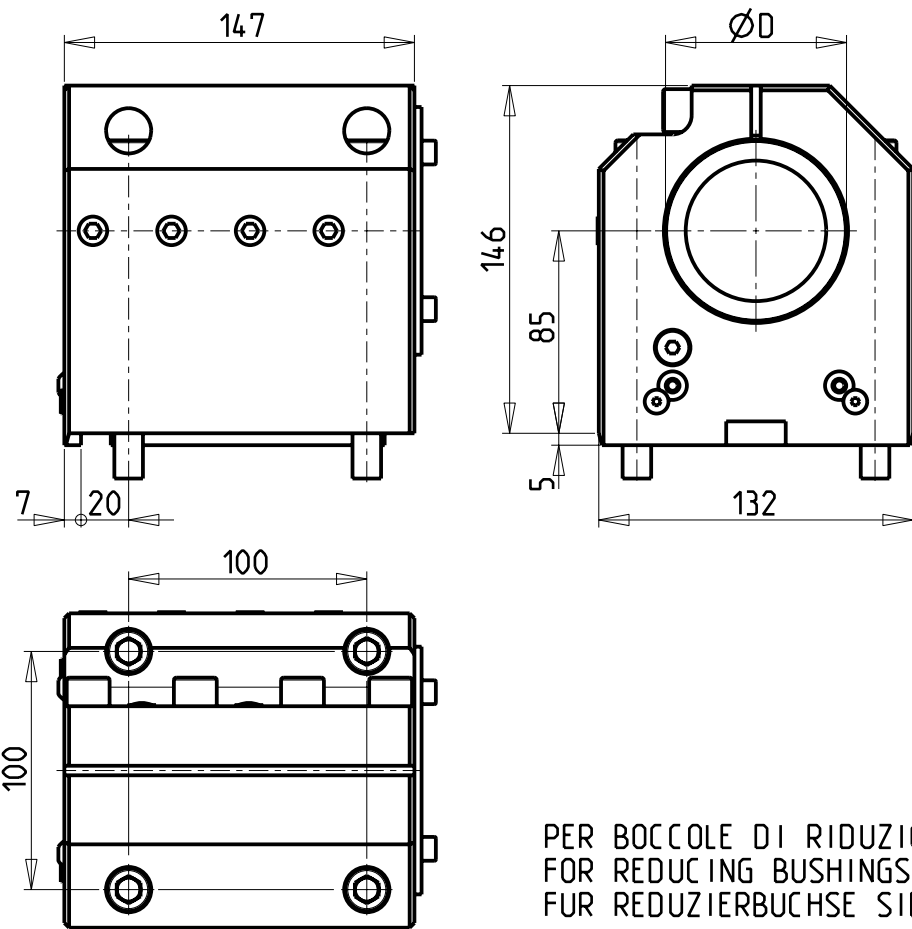

KIT ADDUZIONE INTERNA (OPZIONALE)
 KIT FOR INTERNAL COOLANT (OPTIONAL)
 KIT FUER INTERNE KUEHLMITTELZUFUHR (OPTIONAL)
 Ø80 cod. KIT1002013
 Ø3" cod. KIT1002014

SOLO GUARNIZIONE (OPZIONALE)
 ONLY SEAL (OPTIONAL)
 NUR DICHTUNG (OPTIONAL)
 cod. MNL0310005

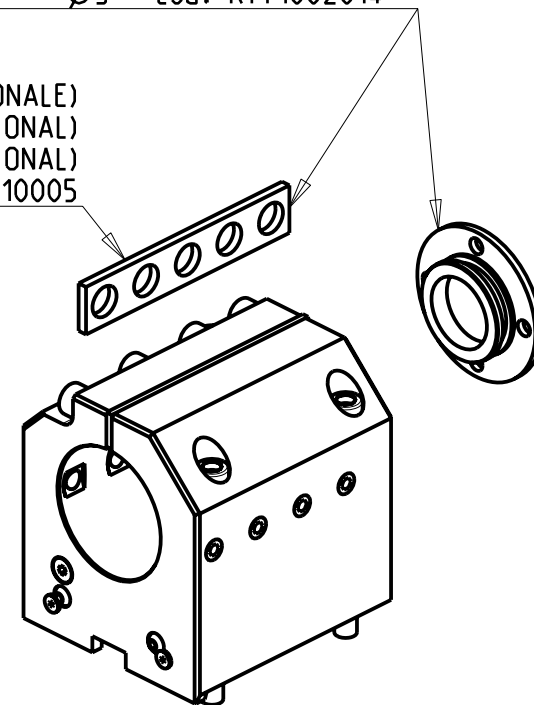

PER BOCCOLE DI RIDUZIONE VEDI PAG. TBL150-1-00
 FOR REDUCING BUSHINGS SEE PAGE TBL150-1-00
 FÜR REDUZIERBUCHSE SIEHE SEITE TBL150-1-00

Cod. MT	N°Utensili N°Tools N°Werkzeuge	Reversibile lato mandrino/contromandrino Reversible sub/main spindle side Umkehrbare Spindel-seite/ Gegenspindel-seite	Lubrificazione int. opzionale Coolant through optional Innenkuehlung Optional	Lubrificazione est. Ext. coolant Aussenkuehlung	Misure Dimensions Masse	D
DW00348000	1	X	X	X	mm	80
DW00347620	1	X	X	X	Inch	3"

HYUNDAI-KIA (WIA)
 MOD: SKT600LM (L600LMA) - SKT700LM (L700LMA) (LV1100RM)

PORTAUTENSILE ASSIALE PER BARENO Ø80mm / Ø3" H=85mm
 Axial single boring bar holder Ø80mm / Ø3" H=85mm
 Axial Bohrhälter Ø80mm / Ø3" H=85mm

M.T. srl

Via Casino Albini 480
 Tel. 0541/956034-957884
 Fax 0541/956341
 47842 S. GIOVANNI IN M. (RN)
 e-mail: mtma@mtmarchetti.com
 http://www.mtmarchetti.com

PRODUZIONE MODULI ROTANTI



PAGINA KIA580-5-20