

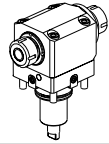

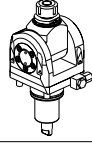

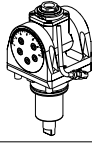

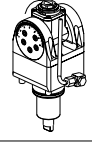

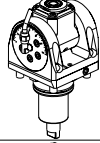

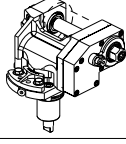
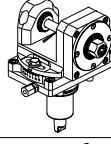
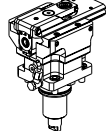
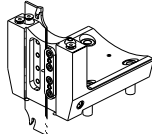

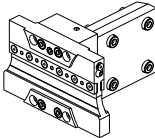

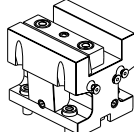

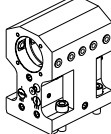
		PAGINA Page Seite
<b>MODULO MOTORIZZATO RADIALE</b> Radial driven tool Radial angetriebenes Werkzeug		HWC010.1.00 
<b>MODULO MOTORIZZATO RADIALE DISASSATO IN Z 36mm</b> Radial driven tool re-directed in Z by 36mm Radial angetriebenes Werkzeug achsversetzt in Z um 36mm		HWC030.1.10 
<b>MODULO MOTORIZZATO RADIALE RIDOTTO I=2:1 DISASSATO IN Z 36mm</b> Radial geared-down I=2:1 driven tool re-directed in Z by 36mm Radial angetriebenes Werkzeug untersetzt I=2:1 achsversetzt in Z um 36mm		HWC030.1.20 
<b>MODULO MOTORIZZ. RADIALE MOLTIPLICATO I=1:2 DISASSATO IN Z 36mm</b> Radial geared-up I=1:2 driven tool re-directed in Z by 36mm Radial angetriebenes Werkzeug uebersetzt I=1:2 achsversetzt in Z um 36mm		HWC030.1.30 
<b>MODULO MOTORIZ. RADIALE MOLTIPLICATO I=1:5,625</b> Radial geared-up I=1:5.625 driven tool Radial angetriebenes Werkzeug uebersetzt I=1:5.625		HWC060.1.00 
<b>MODULO MOTORIZZATO ASSIALE H=60mm</b> Axial driven tool H=60mm Axial angetriebenes Werkzeug H=60mm		HWC150.1.10 
<b>MODULO MOTORIZZATO ASSIALE H=70mm</b> Axial driven tool H=70mm Axial angetriebenes Werkzeug H=70mm		HWC150.1.20 
<b>MODULO MOTORIZZATO ASSIALE H=85mm</b> Axial driven tool H=85mm Axial angetriebenes Werkzeug H=85mm		HWC150.1.30 
<b>MODULO MOTORIZZATO ASSIALE ARRETRATO</b> Axial rear-set driven tool Axial angetriebenes Werkzeug zurueckversetzt		HWC180.1.10 
<b>MODULO MOTORIZZATO ASSIALE MOLTIPLICATO I=1:2</b> Axial geared-up I=1:2 driven tool Axial angetriebenes Werkzeug uebersetzt I=1:2		HWC200.1.10 
<b>MODULO MOTORIZZATO ASSIALE MOLTIPLICATO I=1:5,625</b> Axial geared-up I=1:5.625 driven tool Axial angetriebenes Werkzeug uebersetzt I=1:5.625		HWC210.1.10 
<b>MODULO MOTORIZZATO ASSIALE PER POLIGONATURA INTERNA</b> Axial driven tool for internal polygon-making Axial angetriebenes Werkzeug fuer interne Facettierung		HWC230.1.10 

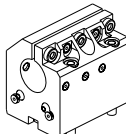

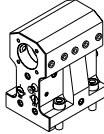

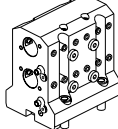

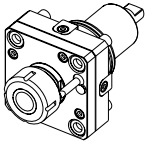
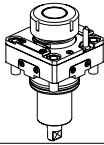
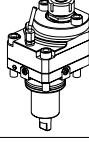
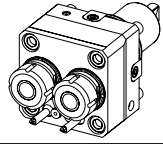
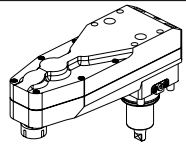
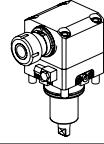
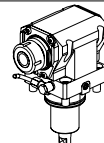
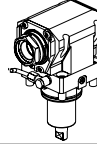
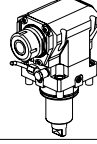
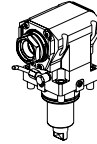
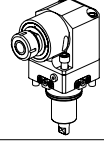
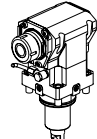



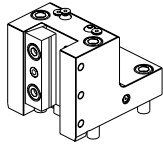

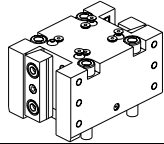

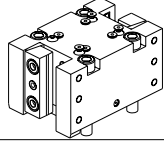

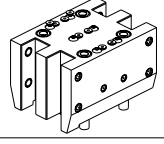
		PAGINA Page Seite
<p><b>MODULO MOTORIZZATO ASSIALE BISPORGENTE</b> Axial opposite face twin driven tool Axial angetriebenes Werkzeug halb vorspringend</p>		<p>HWC 240.1.10</p> <p><b>NEW</b></p>
<p><b>MODULO MOTORIZZATO ASSIALE ARRETRATO BISPORGENTE</b> Axial opposite face rear-set driven tool Axial angetriebenes Werkzeug zurueckversetzt halb vorspringend</p>		<p>HWC 243.1.10</p> <p><b>NEW</b></p>
<p><b>MODULO MOTORIZZATO ORIENTABILE 0-90°</b> 0-90° adjustable angle driven tool Angetriebenes Werkzeug schwenkbar 0-90°</p>		<p>HWC 330.1.00</p> <p><b>NEW</b></p>
<p><b>MODULO MOTORIZZATO ORIENTABILE ±90° H=47,5mm</b> ±90° adjustable angle driven tool H=47.5mm Angetriebenes Werkzeug schwenkbar ±90° H=47.5mm</p>		<p>HWC 335.1.00</p> <p><b>NEW</b></p>
<p><b>MODULO MOTORIZZATO ORIENTABILE ±90° H=83mm</b> ±90° adjustable angle driven tool H=83mm Angetriebenes Werkzeug schwenkbar ±90° H=83mm</p>		<p>HWC 335.1.10</p> <p><b>NEW</b></p>
<p><b>MODULO MOTORIZZATO ORIENTABILE ±90° MOLTIPLICATO I=1:2 H=47,5mm</b> ±90° adjustable angle driven tool geared-up I=1:2 H=47.5mm Angetriebenes Werkzeug schwenkbar ±90° uebersetzt I=1:2 H=47.5mm</p>		<p>HWC 336.1.00</p> <p><b>NEW</b></p>
<p><b>MODULO MOTORIZZATO ORIENTABILE ±90° MOLTIPLICATO I=1:2 H=83mm</b> ±90° adjustable angle driven tool geared-up I=1:2 H=83mm Angetriebenes Werkzeug schwenkbar ±90° uebersetzt I=1:2 H=83mm</p>		<p>HWC 336.1.10</p> <p><b>NEW</b></p>
<p><b>MODULO MOTORIZZATO PORTACREATORE</b> Driven gear hobber Angetriebenes Zahnradwaelzfraes-Werkzeug</p>		<p>HWC 340.1.00</p> <p><b>NEW</b></p>
<p><b>MODULO MOTORIZZATO PORTACREATORE RADIALE</b> Radial driven gear hobber Radial Angetriebenes Zahnradwaelzfraes-Werkzeug</p>		<p>HWC 340.1.30</p> <p><b>NEW</b></p>
<p><b>MODULO MOTORIZZATO STOZZATORE</b> Slotting driven tool Keilnutenstossmaschine</p>		<p>HWC 360.1.00</p> <p><b>NEW</b></p>

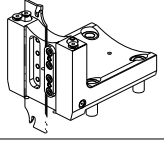
		PAGINA Page Seite
<b>PORTAUTENSILE RADIALE PER LAMA</b> Radial blade holder Radial Abstechhalter		HWC510.1.00 
<b>PORTAUTENSILE PER LAMA DOPPIO</b> Radial double blade holder Radial Doppel-Abstechhalter		HWC520.1.00 
<b>PORTAUTENSILE ASSIALE SINGOLO</b> Axial single static tool Axial Single-Werkzeughalter		HWC552.1.00 
<b>PORTAUTENSILE ASSIALE PER BARENO Ø50mm / Ø2" H=100mm</b> Axial single boring bar holder Ø50mm / Ø2" H=100mm Axial Bohrhälter Ø50mm / Ø2" H=100mm		HWC620.1.10 
<b>PORTAUTENSILE ASSIALE PER BARENO Ø40mm / Ø1 1/2" H=60mm</b> Axial single boring bar holder Ø40mm / Ø1 1/2" H=60mm Axial Bohrhälter Ø40mm / Ø1 1/2" H=60mm		HWC630.1.20 
<b>PORTAUTENSILE ASSIALE PER BARENO Ø40mm / Ø1 1/2" H=100mm</b> Axial single boring bar holder Ø40mm / Ø1 1/2" H=100mm Axial Bohrhälter Ø40mm / Ø1 1/2" H=100mm		HWC640.1.10 
<b>PORTAUT. ASSIALE PER BARENO 2 POSIZIONI Ø25mm / Ø1" / Ø1 1/4" / Ø32mm</b> Axial double boring bar holder Ø25mm / Ø1" / Ø1 1/4" / Ø32mm Axial Bohrhälter 2 positionen Ø25mm / Ø1" / Ø1 1/4" / Ø32mm		HWC862.1.00 

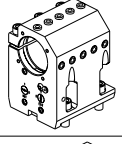
<b>PORTAUTENSILE RADIALE SINGOLO ARRETRATO COROMANT CAPTO®</b> Radial single rear-set static tool COROMANT CAPTO® Radial Single-Werkzeughalter zurueckversetzt COROMANT CAPTO®		HWC430.A.40 
--	---	--

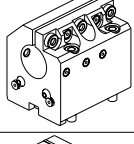
		PAGINA Page Seite
<p><b>MODULO MOTORIZZATO RADIALE</b> Radial driven tool Radial angetriebenes Werkzeug</p>		<p>HW C 010.2.00</p> <p><b>NEW</b></p>
<p><b>MODULO MOTORIZZATO RADIALE MAGGIORATO</b> Radial reinforced driven tool Radial angetriebenes Werkzeug vergrößert</p>		<p>HW C 020.2.00</p> <p><b>NEW</b></p>
<p><b>MODULO MOTORIZZATO RADIALE MOLTIPLICATO I=1:2 DISASSATO IN Z 36mm</b> Radial geared-up I=1:2 driven tool re-directed in Z by 36mm Radial angetriebenes Werkzeug uebersetzt I=1:2 achsversetzt in Z um 36mm</p>		<p>HW C 030.2.30</p> <p><b>NEW</b></p>
<p><b>MODULO MOTORIZZATO RADIALE 2 USCITE IN Y</b> Radial single side twin head driven tool in Y Radial angetriebenes Werkzeug 2 Ausgaenge in Y</p>		<p>HW C 080.2.00</p> <p><b>NEW</b></p>
<p><b>MODULO MOTORIZZATO RADIALE ROVESCiato DISASSATO IN Z 250mm</b> Radial inverted driven tool re-directed in Z by 250mm Radial angetriebenes Werkzeug ungekehrt achsversetzt in Z um 250mm</p>		<p>HW C 120.2.10</p> <p><b>NEW</b></p>
<p><b>MODULO MOTORIZZATO ASSIALE H=72mm</b> Axial driven tool H=72mm Axial angetriebenes Werkzeug H=72mm</p>		<p>HW C 150.2.10</p> <p><b>NEW</b></p>
<p><b>MODULO MOTORIZZATO ASSIALE H=72mm</b> Axial driven tool H=72mm Axial angetriebenes Werkzeug H=72mm</p>		<p>HW C 150.2.11</p> <p><b>NEW</b></p>
<p><b>MODULO MOTORIZZATO ASSIALE MTSK H=72mm</b> Axial MTSK driven tool H=72mm Axial MTSK angetriebenes Werkzeug H=72mm</p>		<p>HW C 150.2.11.K</p> <p><b>NEW</b></p>
<p><b>MODULO MOTORIZZATO ASSIALE H=85mm</b> Axial driven tool H=85mm Axial angetriebenes Werkzeug H=85mm</p>		<p>HW C 150.2.15</p> <p><b>NEW</b></p>
<p><b>MODULO MOTORIZZATO ASSIALE MTSK H=85mm</b> Axial MTSK driven tool H=85mm Axial MTSK angetriebenes Werkzeug H=85mm</p>		<p>HW C 150.2.15.K</p> <p><b>NEW</b></p>
<p><b>MODULO MOTORIZZATO ASSIALE H=100mm</b> Axial driven tool H=100mm Axial angetriebenes Werkzeug H=100mm</p>		<p>HW C 150.2.20</p> <p><b>NEW</b></p>
<p><b>MODULO MOTORIZZATO ASSIALE H=100mm</b> Axial driven tool H=100mm Axial angetriebenes Werkzeug H=100mm</p>		<p>HW C 150.2.21</p> <p><b>NEW</b></p>

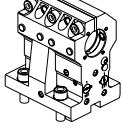



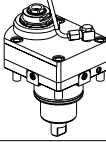
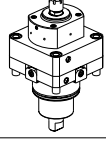
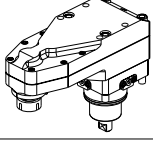
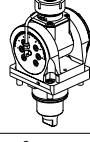
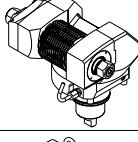
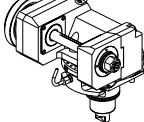

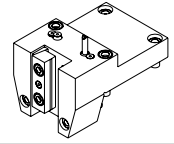
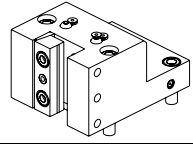
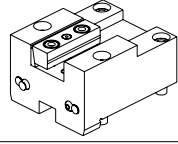
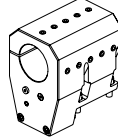



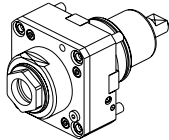

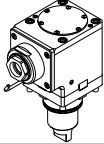

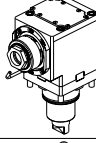
		PAGINA Page Seite
<p><b>MODULO MOTORIZZATO ASSIALE MTSK H=100mm</b> Axial MTSK driven tool H=100mm Axial MTSK angetriebenes Werkzeug H=100mm</p>		<p>HW C 150.2.21.K</p> <p><b>NEW</b></p>
<p><b>MODULO MOTORIZZATO ASSIALE MOLTIPLICATO I=1:2</b> Axial geared-up I=1:2 driven tool Axial angetriebenes Werkzeug uebersetzt I=1:2</p>		<p>HW C 200.2.20</p> <p><b>NEW</b></p>
<p><b>MODULO MOTORIZZATO ASSIALE BISPORGENTE H=72mm</b> Axial opposite face driven tool H=72mm Axial angetriebenes Werkzeug halb vorspringend H=72mm</p>		<p>HW C 240.2.10</p> <p><b>NEW</b></p>
<p><b>MODULO MOTORIZZATO ASSIALE BISPORGENTE H=85mm</b> Axial opposite face driven tool H=85mm Axial angetriebenes Werkzeug halb vorspringend H=85mm</p>		<p>HW C 240.2.15</p> <p><b>NEW</b></p>
<p><b>MODULO MOTORIZZATO ASSIALE BISPORGENTE H=100mm</b> Axial opposite face twin driven tool H=100mm Axial angetriebenes Werkzeug halb vorspringend H=100mm</p>		<p>HW C 240.2.20</p> <p><b>NEW</b></p>
<p><b>MODULO MOTORIZZATO ASSIALE BISPORGENTE H=100mm</b> Axial opposite face driven tool H=100mm Axial angetriebenes Werkzeug halb vorspringend H=100mm</p>		<p>HW C 240.2.21</p> <p><b>NEW</b></p>
<p><b>MODULO MOTORIZZATO ASSIALE 2 USCITE IN Y</b> Axial single side twin head driven tool in Y Axial angetriebenes Werkzeug 2 Ausgaenge in Y</p>		<p>HW C 260.2.10</p> <p><b>NEW</b></p>
<p><b>MODULO MOTORIZZATO ORIENTABILE 0-90°</b> 0-90° adjustable angle driven tool Angetriebenes Werkzeug schwenkbar 0-90°</p>		<p>HW C 330.2.00</p> <p><b>NEW</b></p>
<p><b>MODULO MOTORIZZATO PORTACREATORE</b> Driven gear hobber Angetriebenes Zahnradwaelzfraes-Werkzeug</p>		<p>HW C 340.2.00</p> <p><b>NEW</b></p>
<p><b>MODULO MOTORIZZATO PORTACREATORE MAGGIORATO</b> Reinforced driven gear hobber Angetriebenes Zahnradwaelzfraes-Werkzeug vergroessert</p>		<p>HW C 340.2.60</p> <p><b>NEW</b></p>
<p><b>MODULO MOTORIZZATO PER LUNETTA RETRATTILE (TAGLIA 2)</b> Driven toolholder for sliding steady rest (Size 2) Luenettenwerkzeug zurueck versetzte Version (Grossesse 2)</p>		<p>HW C 363.2.00</p> <p><b>NEW</b></p>

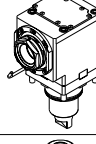
		PAGINA Page Seite
<b>PORTAUTENSILE RADIALE SINGOLO</b> Radial single static tool Radial Single-Werkzeughalter		HWC 423.2.00 
<b>PORTAUTENSILE RADIALE DOPPIO H=90mm</b> Radial double static tool H=90mm Radial Doppel-Werkzeughalter H=90mm		HWC 453.2.00 
<b>PORTAUTENSILE RADIALE DOPPIO H=75mm</b> Radial double static tool H=75mm Radial Doppel-Werkzeughalter H=75mm		HWC 453.2.10 
<b>PORTAUTENSILE RADIALE DOPPIO SOVRAPPOSTO</b> Radial double side twin static tool Radial Doppel-Werkzeughalter ueberlagert		HWC 463.2.00 
<b>PORTAUTENSILE RADIALE PER LAMA</b> Radial blade holder Radial Abstechhalter		HWC 510.2.00 
<b>PORTAUTENSILE ASSIALE PER BARENO Ø60mm H=100mm</b> Axial single boring bar holder Ø60mm H=100mm Axial Bohrhalter Ø60mm H=100mm		HWC 590.2.20 
<b>PORTAUTENSILE ASSIALE PER BARENO Ø40mm/Ø1 1/2"/Ø50mm/Ø2" H=72mm</b> Axial single boring bar holder Ø40mm/Ø1 1/2"/Ø50mm/Ø2" H=72mm Axial Bohrhalter Ø40mm/Ø1 1/2"/Ø50mm/Ø2" H=72mm		HWC 610.2.20 
<b>PORTAUTENSILE ASSIALE PER BARENO Ø40mm H=100mm</b> Axial single boring bar holder Ø40mm H=100mm Axial Bohrhalter Ø40mm H=100mm		HWC 640.2.20 

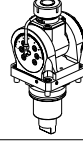
		PAGINA Page Seite
<p><b>MODULO MOTORIZZATO RADIALE</b> Radial driven tool Radial angetriebenes Werkzeug</p>		<p>HW C 010.3.00</p> <p><b>NEW</b></p>
<p><b>MODULO MOTORIZZATO RADIALE DISASSATO IN Z 47.5mm</b> Radial driven tool re-directed in Z by 47.5mm Radial angetriebenes Werkzeug achsversetzt in Z um 47.5mm</p>		<p>HW C 033.3.10</p> <p><b>NEW</b></p>
<p><b>MODULO MOTOR. RADIALE MOLTIPLICATO I=1:2 DISASSATO IN Z 47.5mm</b> Radial geared-up I=1:2 driven tool re-directed in Z by 47.5mm Radial angetriebenes Werkzeug uebersetzt I=1:2 achsversetzt in Z um 47.5mm</p>		<p>HW C 033.3.30</p> <p><b>NEW</b></p>
<p><b>MODULO MOTORIZZATO RADIALE MOLTIPLICATO I=1:4</b> Radial geared-up I=1:4 driven tool Radial angetriebenes Werkzeug uebersetzt I=1:4</p>		<p>HW C 058.3.00</p> <p><b>NEW</b></p>
<p><b>MODULO MOTORIZZATO RADIALE ROVESCiato DISASSATO IN Z 187.5</b> Radial inverted driven tool re-directed in Z by 187.5 mm Radial angetriebenes Werkzeug umgekehrt achsversetzt in Z um 187.5 mm</p>		<p>HW C 120.3.10</p> <p><b>NEW</b></p>
<p><b>MODULO MOTORIZZATO ASSIALE MAGGIORATO H=90mm</b> Axial reinforced driven tool H=90mm Axial angetriebenes Werkzeug vergroessert H=90mm</p>		<p>HW C 170.3.20</p> <p><b>NEW</b></p>
<p><b>MODULO MOTORIZZATO ORIENTABILE +/-90°</b> +/-90° adjustable angle driven tool Angetriebenes Werkzeug schwenkbar +/-90°</p>		<p>HW C 339.3.00</p> <p><b>NEW</b></p>
<p><b>MODULO MOTORIZZATO PORTACREATORE MAGGIORATO</b> Reinforced driven gear hobber Angetriebenes Zahnradwaelzfraes-Werkzeug vergroessert</p>		<p>HW C 340.3.60</p> <p><b>NEW</b></p>
<p><b>MODULO MOTORIZZATO PORTACREATORE (TAGLIA GRANDE)</b> Driven gear hobber (big size) Angetriebenes Zahnradwaelzfraes-Werkzeug (grosse version)</p>		<p>HW C 340.3.80</p> <p><b>NEW</b></p>

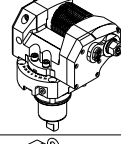
		PAGINA Page Seite
<p><b>PORTAUTENSILE RADIALE SINGOLO</b> Radial single static tool Radial Single-Werkzeughalter</p>		<p>HW C 423.3.00</p> <p><b>NEW</b></p>
<p><b>PORTAUTENSILE RADIALE SINGOLO</b> Radial single static tool Radial Single-Werkzeughalter</p>		<p>HW C 423.3.01</p> <p><b>NEW</b></p>
<p><b>PORTAUTENSILE ASSIALE SINGOLO</b> Axial single static tool Axial Single-Werkzeughalter</p>		<p>HW C 552.3.00</p> <p><b>NEW</b></p>
<p><b>PORTAUTENSILE ASSIALE PER BARENO Ø80mm H=110mm</b> Axial single boring bar holder Ø80mm H=110mm Axial Bohrhalter Ø80mm H=110mm</p>		<p>HW C 580.3.20</p> <p><b>NEW</b></p>

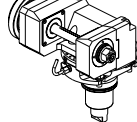

		PAGINA Page Seite
<b>MODULO MOTORIZZATO RADIALE</b> Radial driven tool Radial angetriebenes Werkzeug		HWC 010.4.00 
<b>MODULO MOTORIZZATO ASSIALE H=110mm</b> Axial driven tool H=110mm Axial angetriebenes Werkzeug H=110mm		HWC 150.4.20 
<b>MODULO MOTORIZZATO ASSIALE RIDOTTO I=2:1 H=110mm</b> Axial geared-down I=2:1 driven tool H=110mm Axial angetriebenes Werkzeug untersetzt I=2:1 H=110mm		HWC 190.4.20 
<b>MODULO MOTORIZZATO ASSIALE MTSK RIDOTTO I=2:1 H=110mm</b> Axial MTSK geared-down I=2:1 driven tool H=110mm Axial MTSK angetriebenes Werkzeug untersetzt I=2:1 H=110mm		HWC 190.4.20.K 
<b>MODULO MOTORIZZATO ORIENTABILE +/-90°</b> +/-90° adjustable angle driven tool Angetriebenes Werkzeug schwenkbar +/-90°		HWC 339.4.00 
<b>MODULO MOTORIZZATO PORTACREATORE MAGGIORATO</b> Reinforced driven gear hobber Angetriebenes Zahnradwaelzfraes-Werkzeug vergroessert		HWC 340.4.60 
<b>MODULO MOTORIZZATO PORTACREATORE (TAGLIA GRANDE)</b> Driven gear hobber (big size) Angetriebenes Zahnradwaelzfraes-Werkzeug (grosse version)		HWC 340.4.80 



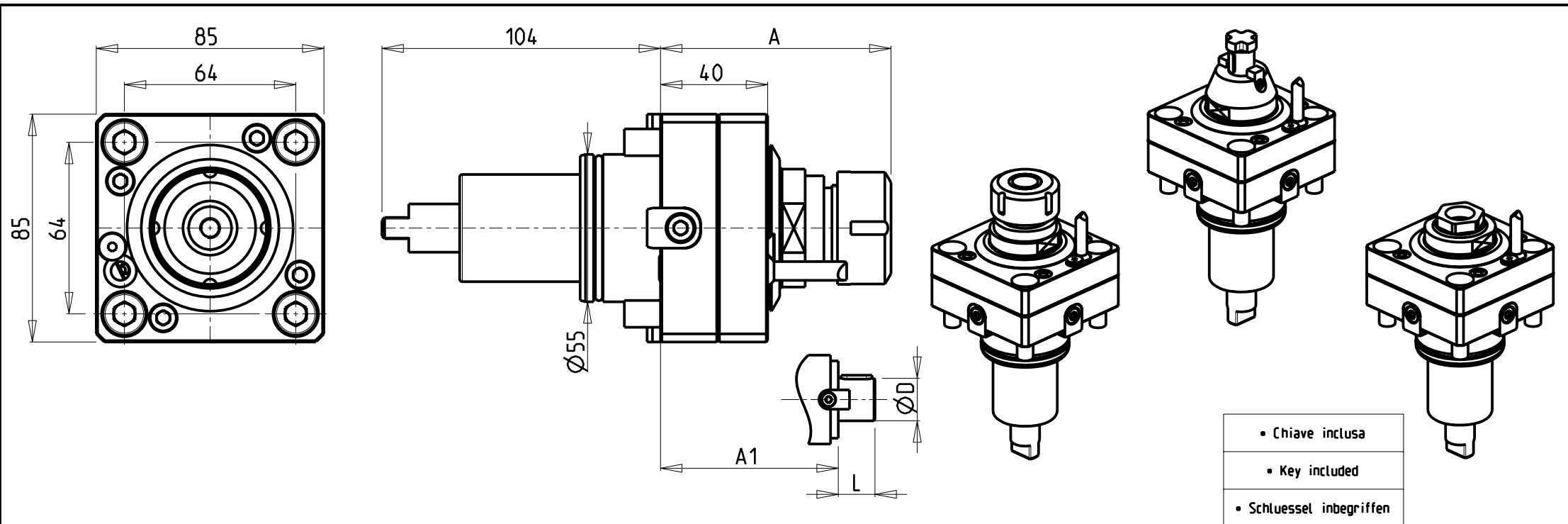

Cod. MT	Cod. EPPINGER	Mandrino Spindle Spindel	I	RPM	Coppia Max Max Torque Max Drehmoment	Lubrificazione int. Coolant through Innenkuehlung	Lubrificazione est. Ext. coolant Aussenkuehlung	A	A1	D	L	CHIAVI NON INCLUSE Keys not included Schluessel nicht einbegriffen		
0271325	-	ER25	1:1	6000	50Nm		X	86.06	-	-	-	CHSTER25	CHUB40 o 0270018	NEW
0270225	-	ER25	1:1	6000	50Nm	P=30bar	X	86.06	-	-	-	CHSTER25	CHUB40 o 0270018	NEW
0271525	7.070.679	ER A 25	1:1	6000	50Nm		X	63.03	-	-	-	CHUB27	CHUB40 o 0270018	NEW
0271025	-	ER A 25	1:1	6000	50Nm	P=30bar	X	63.03	-	-	-	CHUB27	CHUB40 o 0270018	NEW
0272232	-	ER32	1:1	6000	50Nm		X	85.06	-	-	-	CHSTER32	CHUB40 o 0270018	NEW
0272332	-	ER32	1:1	6000	50Nm	P=30bar	X	85.16	-	-	-	CHSTER32	CHUB40 o 0270018	NEW
0271617	-	Ø16x17	1:1	6000	50Nm		X	-	70	16	17	CH_VTCROCE_M08	CHUB40 o 0270018	NEW
0272219	-	Ø22x19	1:1	6000	50Nm		X	-	70	22	19	CH_VTCROCE_M10	CHUB40 o 0270018	NEW

HW ACHEON  
CUTEX 160

MODULO MOTORIZZATO RADIALE  
Radial driven tool  
Radial angetriebenes Werkzeug

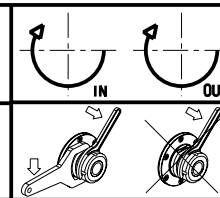

**M.T. srl**  
Via Casino Albini 480  
Tel. 0541/956034-957884  
Fax 0541/956341  
47842 S. GIOVANNI IN M. (RN)  
e-mail: mtma@mtmarchetti.com  
http://www.mtmarchetti.com

PRODUZIONE MODULI ROTANTI



PAGINA HW C010-1-00

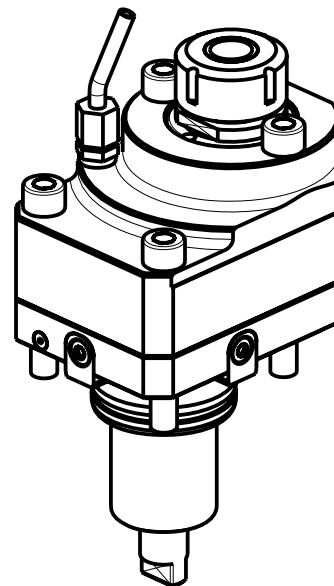
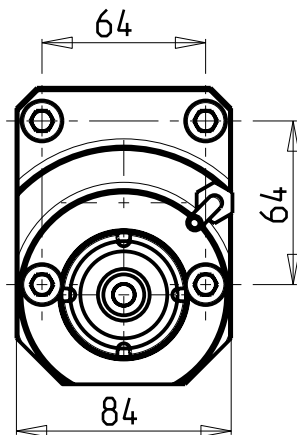
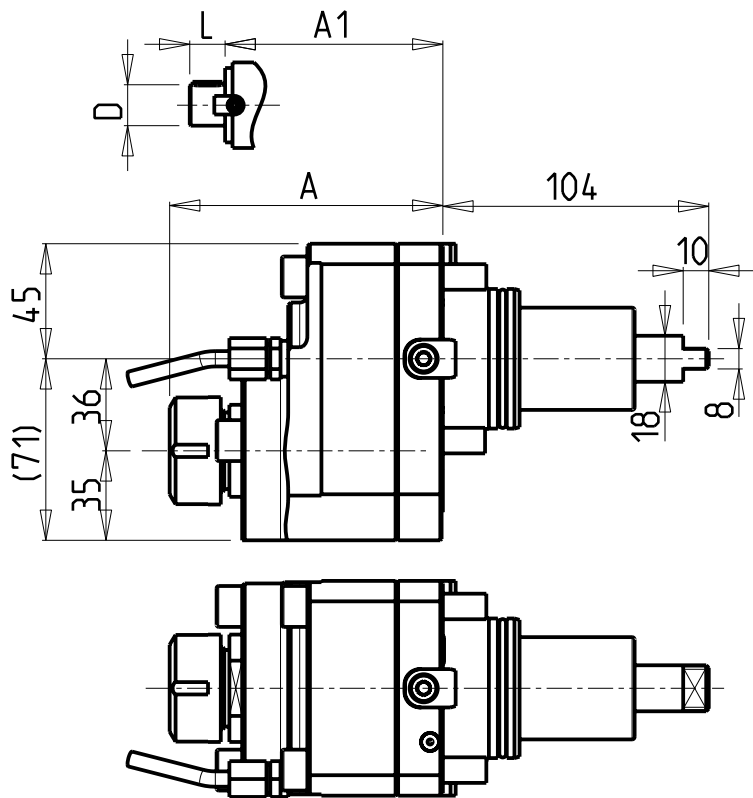

**ATTENZIONE - ATTENTION - ACHTUNG**

- VERIFICARE LE MISURE DI INGOMBRO PER POSSIBILE INTERFERENZA SU ALCUNI MODELLI DI MACCHINE
- Please check the overall sizes for possible interferences on some machine models
- Bitte überprüfen sie das ausmass um mögliche interferenzen auf einigen maschinen modellen zu vermeiden

- Chiave inclusa
- Key included
- Schluessel inbegriffen

Cod. MT	Mandrino Spindle Spindel	I	RPM	Coppia Max Max Torque Max Drehmoment	Reversibile lato mandrino/contromandrino Reversible sub/main spindle side Umkehrbare Spindel-seite/ Gegenspindel-seite	Lubrificazione est. Ext. coolant Aussenkuehlung	A	A1	D	L	CHIAVI NON INCLUSE Keys not included Schluessel nicht einbegriffen	
0720025	ER25	1:1	6000	50Nm	X	X	106.86	-	-	-	CHSTER25	MNL0210007
0720032	ER32	1:1	6000	50Nm	X	X	120.56	-	-	-	CHSTER32	MNL0210007
0720016	∅16x17	1:1	6000	50Nm	X	X	-	88.5	16	17	CH_VTCROCE_M08	MNL0210007
0720022	∅22x19	1:1	6000	50Nm	X	X	-	90.5	22	19	CH_VTCROCE_M10	MNL0210007
0720027	∅27x21	1:1	6000	50Nm	X	X	-	92.5	27	21	CH_VTCROCE_M12	MNL0210007

NEW  
NEW  
NEW  
NEW  
NEW

HW ACHEON  
CUTEX 160

MODULO MOTORIZZATO RADIALE DISASSATO IN Z 36mm  
Radial driven tool re-directed in Z by 36mm  
Radial angetriebenes Werkzeug achsversetzt in Z um 36mm

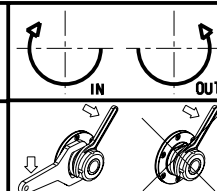

**M.T. srl**

Via Casino Albini 480  
Tel. 0541/956034-957884  
Fax 0541/956341

47842 S. GIOVANNI IN M. (RN)  
e-mail: mtma@mtmarchetti.com  
http://www.mtmarchetti.com

PRODUZIONE MODULI ROTANTI



PAGINA HW C030-1-10

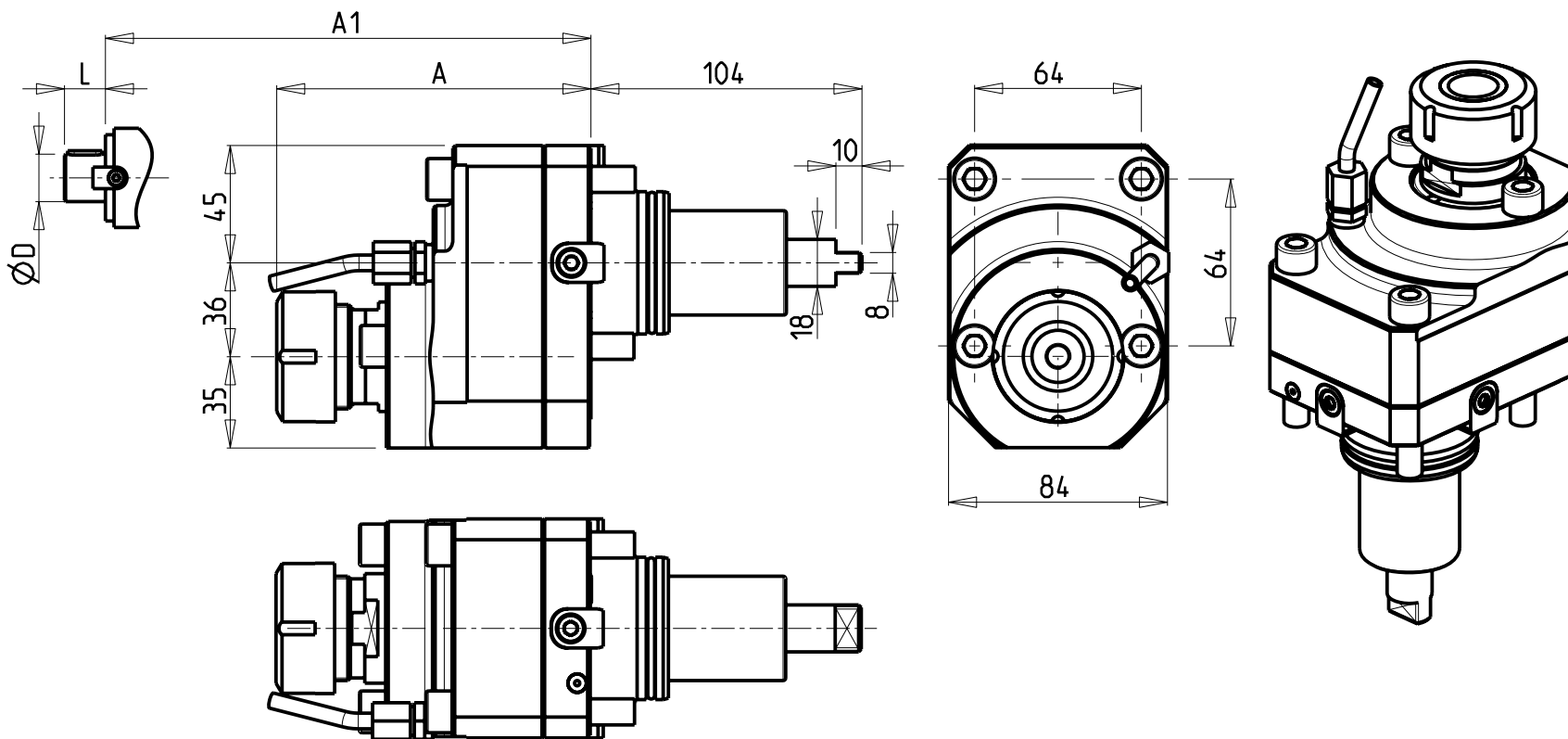

ATTENZIONE - ATTENTION - ACHTUNG

- VERIFICARE LE MISURE DI INGOMBRO PER POSSIBILE INTERFERENZA SU ALCUNI MODELLI DI MACCHINE
- Please check the overall sizes for possible interferences on some machine models
- Bitte überprüfen sie das ausmass um mögliche interferenzen auf einigen maschinen modellen zu vermeiden

• Chiave inclusa

• Key included

• Schluessel inbegriffen

Cod. MT	Mandrino Spindle Spindel	I	RPM	Coppia Max Max Torque Max Drehmoment	Reversibile lato mandrino/contromandrino Reversible sub/main spindle side Umkehrbare Spindelsete/Gegenspindelsete	Lubrificazione est. Ext. coolant Aussenkuehlung	A	A1	D	L	CHIAVI NON INCLUSE Keys not included Schluessel nicht einbegriffen	
0722132	ER32	2:1	3000	65Nm	X	X	120.56	-	-	-	CHSTER32	MNL0210007
0722116	Ø16x17	2:1	3000	65Nm	X	X	-	88.5	16	17	CH_VTCROCE_M08	MNL0210007
0722122	Ø22x19	2:1	3000	65Nm	X	X	-	90.5	22	19	CH_VTCROCE_M10	MNL0210007
0722127	Ø27x21	2:1	3000	65Nm	X	X	-	92.5	27	21	CH_VTCROCE_M12	MNL0210007

NEW

NEW

NEW

NEW

HW ACHEON  
CUTEX 160

MODULO MOTORIZZATO RADIALE RIDOTTO I=2:1 DISASSATO IN Z 36mm  
Radial geared-down I=2:1 driven tool re-directed in Z by 36mm  
Radial angetriebenes Werkzeug untersetzt I=2:1 achsversetzt in Z um 36mm

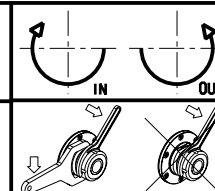

**M.T. srl**

Via Casino Albini 480  
Tel. 0541/956034-957884  
Fax 0541/956341

47842 S. GIOVANNI IN M. (RN)  
e-mail: mtma@mtmarchetti.com  
http://www.mtmarchetti.com

PRODUZIONE MODULI ROTANTI



PAGINA HW C030-1-20

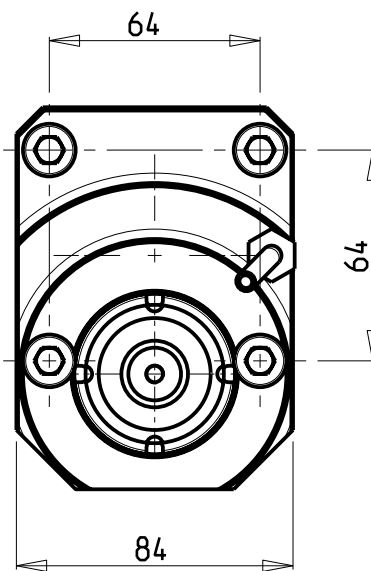
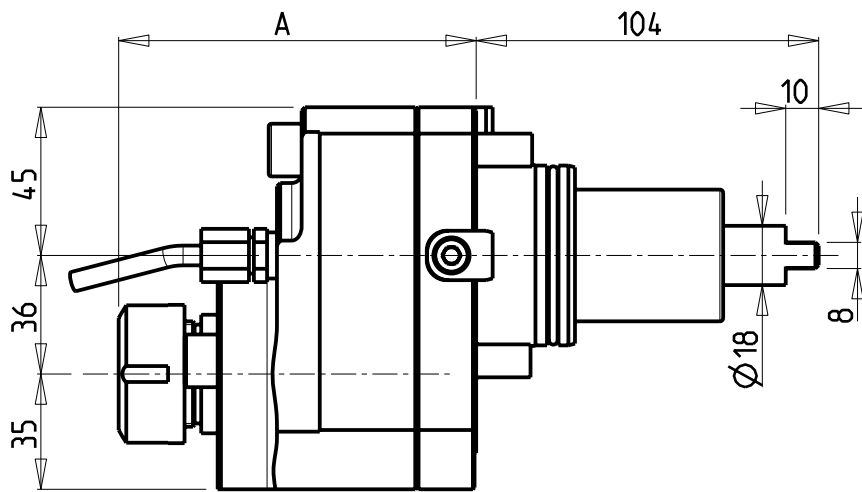

**ATTENZIONE - ATTENTION - ACHTUNG**

- VERIFICARE LE MISURE DI INGOMBRO PER POSSIBILE INTERFERENZA SU ALCUNI MODELLI DI MACCHINE
- Please check the overall sizes for possible interferences on some machine models
- Bitte überprüfen sie das ausmass um mögliche interferenzen auf einigen maschinen modellen zu vermeiden

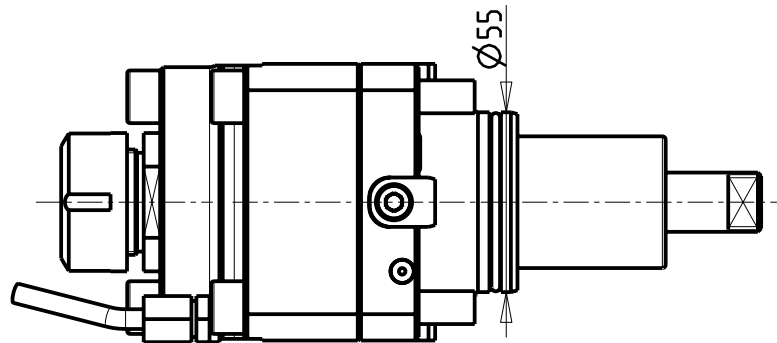
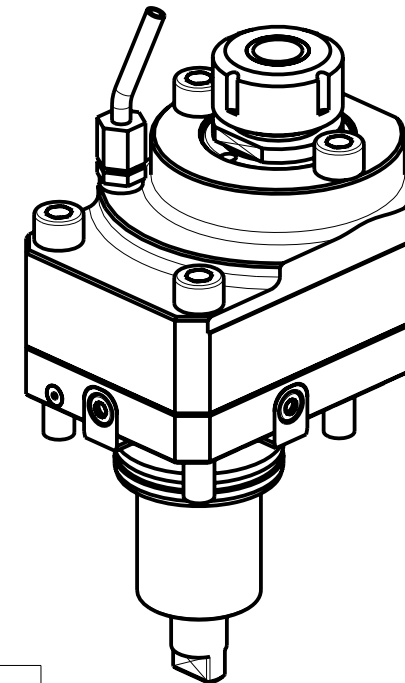

Cod. MT	Mandrino Spindel Spindel	I	RPM	Coppia Max Max Torque Max Drehmoment	Reversibile lato mandrino/contromandrino Reversible sub/main spindle side Umkehrbare Spindel-seite/ Gegenspindel-seite	Lubrificazione est. Ext. coolant Aussenkuehlung	A	CHIAVI NON INCLUSE Keys not included Schluessel nicht einbegriffen
0721225	ER25	1:2	12000	30Nm	X	X	108.56	CHSTER25 MNL0210007

NEW

HW ACHEON  
CUTEX 160

MODULO MOTORIZZATO RADIALE MOLTIPLICATO I=1:2 DISASSATO IN Z 36mm  
Radial geared-up I=1:2 driven tool re-directed in Z by 36mm  
Radial angetriebenes Werkzeug uebersezt I=1:2 achsversetzt in Z um 36mm

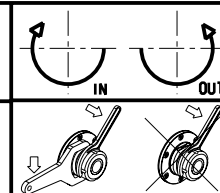

**M.T. srl**

Via Casino Albini 480  
Tel. 0541/956034-957884  
Fax 0541/956341

47842 S. GIOVANNI IN M. (RN)  
e-mail: mtma@mtmarchetti.com  
http://www.mtmarchetti.com

PRODUZIONE MODULI ROTANTI



PAGINA HW C030-1-30

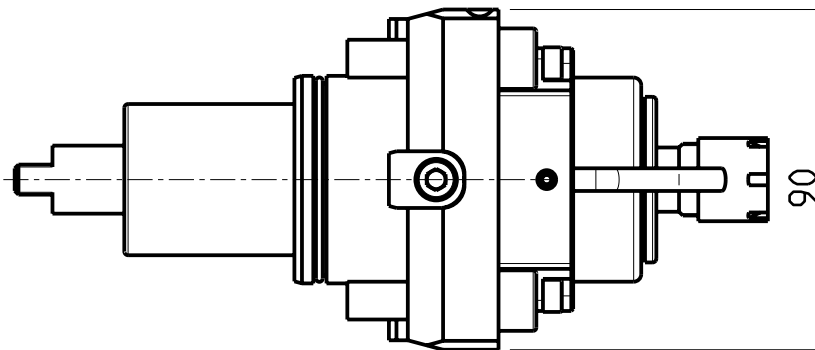
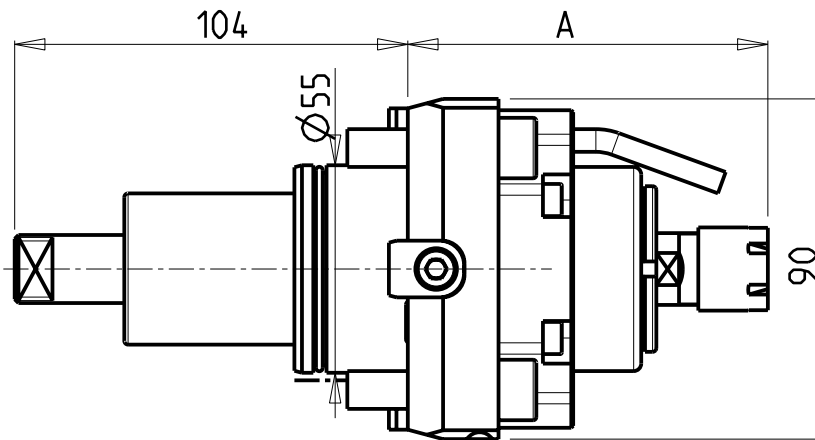
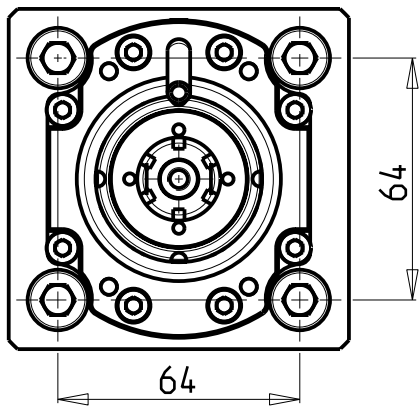

### ATTENZIONE - ATTENTION - ACHTUNG

- Per lo smontaggio degli utensili utilizzare sempre la chiave di contrasto come indicato nel manuale d'uso.
- For disassembly of the tools use always the contrast key as mentioned in the user instructions.
- Fuer das Abmontieren der Werkzeuge immer den Gegenschlüssel benutzen wie in der Bedienungsanleitung erwäehnt.

### ATTENZIONE - ATTENTION - ACHTUNG

- VERIFICARE LE MISURE DI INGOMBRO PER POSSIBILE INTERFERENZA SU ALCUNI MODELLI DI MACCHINE
- Please check the overall sizes for possible interferences on some machine models
- Bitte überprüfen sie das ausmass um mögliche interferenzen auf einigen maschinen modellen zu vermeiden

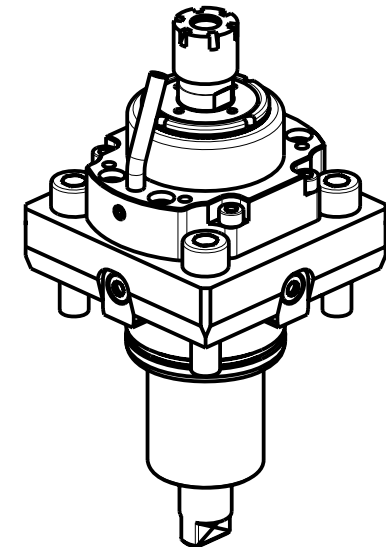

### ATTENZIONE - ATTENTION - ACHTUNG

- PRIMA DI UTILIZZARE IL MOTORIZZATO CONSULTARE LE ISTRUZIONI ALLEGATE!
- BEFORE USING THE DRIVEN TOOL, PLEASE CHECK THE ENCLOSED INSTRUCTION SHEET!
- VOR DER BENUTZUNG DES ANGETRIEBENEN WERKZEUGES, DIE BEILIEGENDEN INSTRUKTIONEN DURCHLESEN!

Cod. MT	Mandrino Spindle Spindel	I	RPM	Coppia Max Max Torque Max Drehmoment	Lubrificazione int. Coolant through Innenkuehlung	Lubrificazione est. Ext. coolant Aussenkuehlung	A	CHIAVI INCLUDE Keys included Schluessel einbegriffen		
DW 00600116	ER16	1:5.625	22500	6Nm		X	95.25	CHMNER16	CHUB17	NEW
DW 00600111	ER11	1:5.625	22500	6Nm	P=30bar	X	107.45	CHMNER11	CHUB11	NEW

HW ACHEON  
CUTEX 160

MODULO MOTORIZZATO RADIALE MOLTIPLICATO I=1:5.625  
Radial geared-up I=1:5.625 driven tool  
Radial angetriebenes Werkzeug uebersetzt I=1:5.625

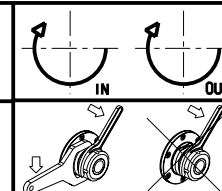

**M.T. srl**

Via Casino Albini 480  
Tel. 0541/956034-957884  
Fax 0541/956341  
47842 S. GIOVANNI IN M. (RN)  
e-mail: mtma@mtmarchetti.com  
http://www.mtmarchetti.com

PRODUZIONE MODULI ROTANTI



PAGINA HWC060-1-00

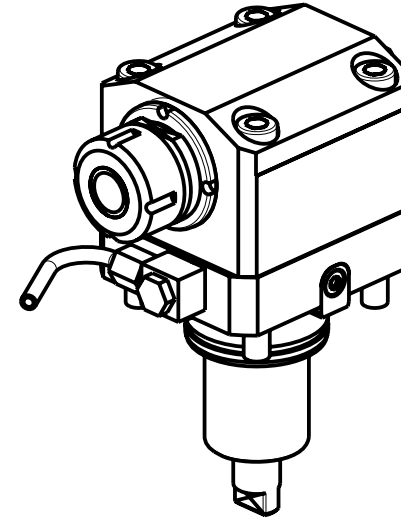
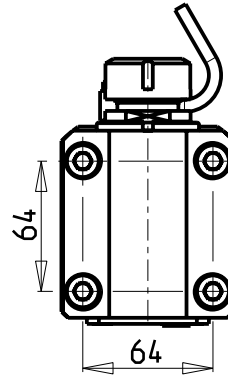
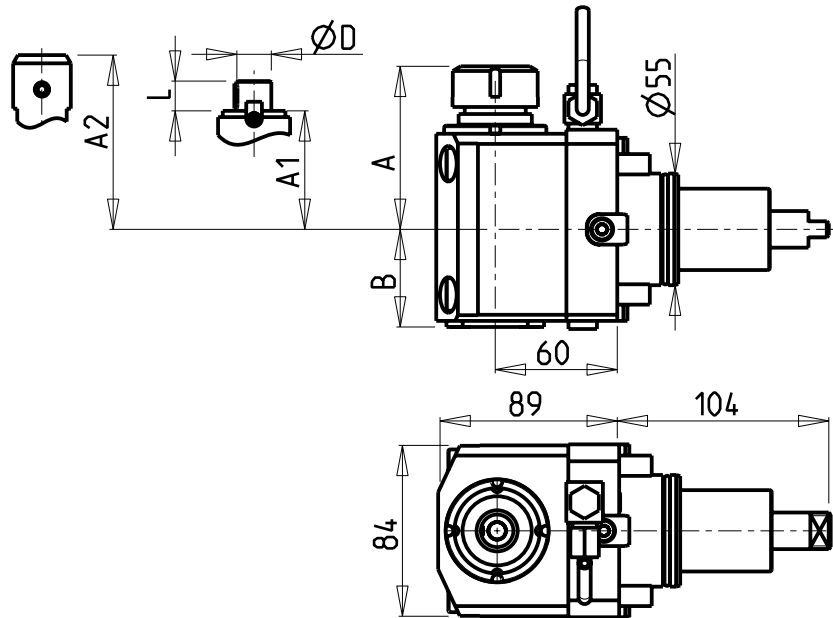

- Chiave inclusa
- Key included
- Schluessel inbegriffen

Cod. MT	Cod. EPPINGER	Mandrino Spindle Spindel	I	RPM	Coppia Max Max Torque Max Drehmoment	Reversibile lato mandrino/contromandrino Reversible sub/main spindle side Umkehrbare Spindelsete/Gegenspindelsete	Lubr.interna Coolant through Innenkuehlung	Lubr. esterna Ext. coolant Aussenkuehlung	A	A1	A2	B	D	L	CHIAVI NON INCLUDE Keys not included Schluessel nicht einbegriffen
0310825	7.070.680	ER25	1:1	6000	50Nm	X		X	80.16	-	-	48	-	-	CHSTER25 CHUB36 o 0100000
0311025	-	ER25	1:1	6000	50Nm	X	P=70bar	X	80.66	-	-	71.5	-	-	CHSTER25 CHUB36 o 0100000
0311432	-	ER32	1:1	6000	50Nm	X		X	97.66	-	-	48	-	-	CHSTER32 CHUB36 o 0100000
0311032	-	ER32	1:1	6000	50Nm	X	P=70bar	X	98.16	-	-	71.5	-	-	CHSTER32 CHUB36 o 0100000
0310022	-	WELDON 20	1:1	6000	50Nm	X		X	-	-	100	48	-	-	
0311617	-	Ø16x17	1:1	6000	50Nm	X		X	-	61	-	48	16	17	CH_VTCROCE_M08 CHUB36 o 0100000
0312219	-	Ø22x19	1:1	6000	50Nm	X		X	-	62	-	48	22	19	CH_VTCROCE_M10 CHUB36 o 0100000
0312240	-	Ø22x40	1:1	6000	50Nm	X		X	-	62	-	48	22	40	CH_VTCROCE_M10 CHUB36 o 0100000
0312721	-	Ø27x21	1:1	6000	50Nm	X		X	-	64	-	48	27	21	CH_VTCROCE_M12 CHUB36 o 0100000
0312733	-	Ø27x33	1:1	6000	50Nm	X		X	-	61	-	48	27	33	CH_VTCROCE_M12 CHUB36 o 0100000
0312750	-	Ø27x50	1:1	6000	50Nm	X		X	-	62.5	-	48	27	50	CH_VTCROCE_M12 CHUB36 o 0100000

HW ACHEON  
 CUTEX 160  
 MODULO MOTORIZZATO ASSIALE H=60mm  
 Axial driven tool H=60mm  
 Axial angetriebenes Werkzeug H=60mm

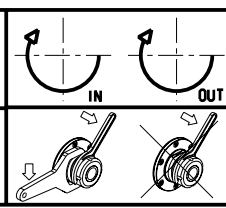

**M.T. srl**  
 Via Casino Albini 480  
 Tel. 0541/956034-957884  
 Fax 0541/956341  
 47842 S. GIOVANNI IN M. (RN)  
 e-mail: mtma@mtmarchetti.com  
 http://www.mtmarchetti.com

PRODUZIONE MODULI ROTANTI



PAGINA HW C 150-1-10



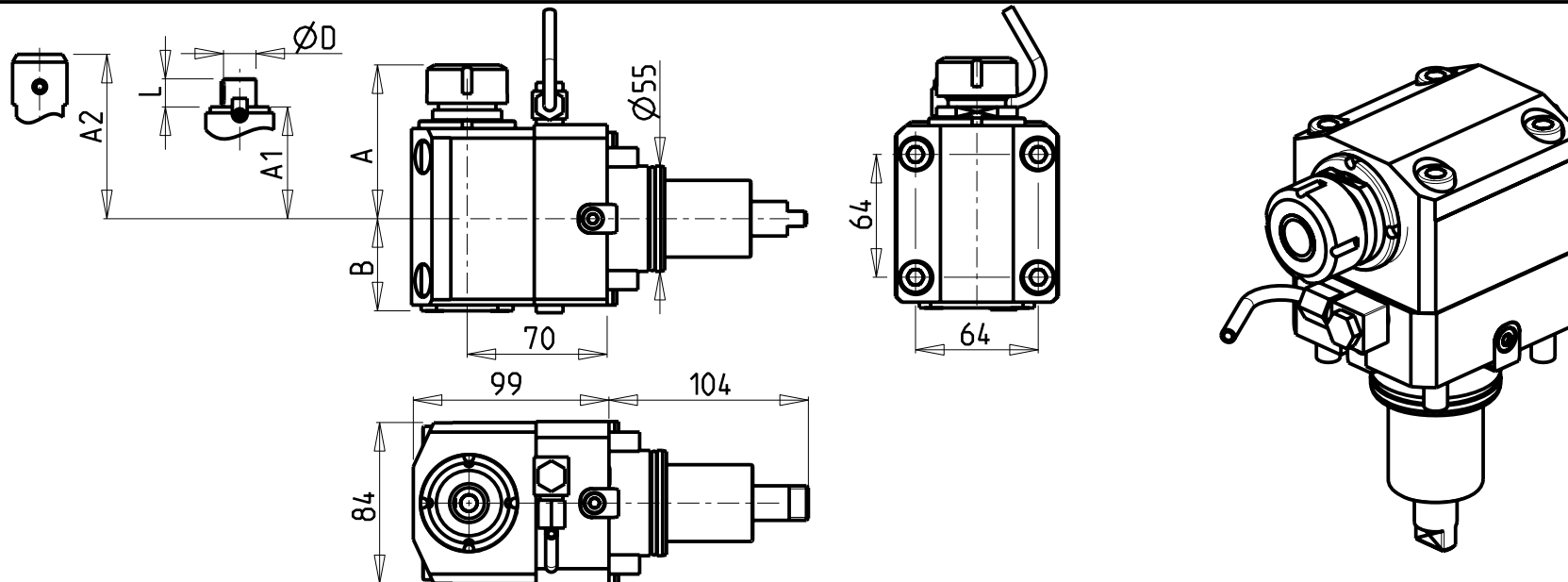

- Chiave inclusa
- Key included
- Schlüssel inbegriffen

Cod. MT	Mandrino Spindle Spindel	I	RPM	Coppia Max Max Torque Max Drehmoment	Reversibile lato mandrino/contromandrino Reversible sub/main spindle side Umkehrbare Spindel-seite/ Gegenspindel-seite	Lubr.interna Coolant through Innenkuehlung	Lubr. esterna Ext. coolant Aussenkuehlung	A	A1	A2	B	D	L	CHIAVI NON INCLUSE Keys not included Schlüssel nicht einbegriffen	
DW 00240125	ER25	1:1	6000	50Nm	X		X	80.16	-	-	48	-	-	CHSTER25	CHUB36 o 0100000
DW 00240225	ER25	1:1	6000	50Nm	X	P=70bar	X	80.66	-	-	71.5	-	-	CHSTER25	CHUB36 o 0100000
DW 00240132	ER32	1:1	6000	50Nm	X		X	97.66	-	-	48	-	-	CHSTER32	CHUB36 o 0100000
DW 00240232	ER32	1:1	6000	50Nm	X	P=70bar	X	98.16	-	-	71.5	-	-	CHSTER32	CHUB36 o 0100000
DW 00240022	WELDON 20	1:1	6000	50Nm	X		X	-	-	100	48	-	-		
DW 00241617	Ø16x17	1:1	6000	50Nm	X		X	-	61	-	48	16	17	CH_VTCROCE_M08	CHUB36 o 0100000
DW 00242219	Ø22x19	1:1	6000	50Nm	X		X	-	62	-	48	22	19	CH_VTCROCE_M10	CHUB36 o 0100000
DW 00242240	Ø22x40	1:1	6000	50Nm	X		X	-	62	-	48	22	40	CH_VTCROCE_M10	CHUB36 o 0100000
DW 00242721	Ø27x21	1:1	6000	50Nm	X		X	-	64	-	48	27	21	CH_VTCROCE_M12	CHUB36 o 0100000
DW 00242733	Ø27x33	1:1	6000	50Nm	X		X	-	61	-	48	27	33	CH_VTCROCE_M12	CHUB36 o 0100000
DW 00242750	Ø27x50	1:1	6000	50Nm	X		X	-	62.5	-	48	27	50	CH_VTCROCE_M12	CHUB36 o 0100000

HW ACHEON  
CUTEX 160

MODULO MOTORIZZATO ASSIALE H=70mm  
Axial driven tool H=70mm  
Axial angetriebenes Werkzeug H=70mm

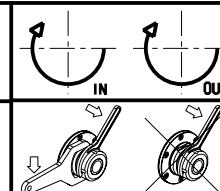

**M.T. srl**  
Via Casino Albini 480  
Tel. 0541/956034-957884  
Fax 0541/956341  
47842 S. GIOVANNI IN M. (RN)  
e-mail: mtma@mtmarchetti.com  
http://www.mtmarchetti.com

PRODUZIONE MODULI ROTANTI



PAGINA HW C 150-1-20

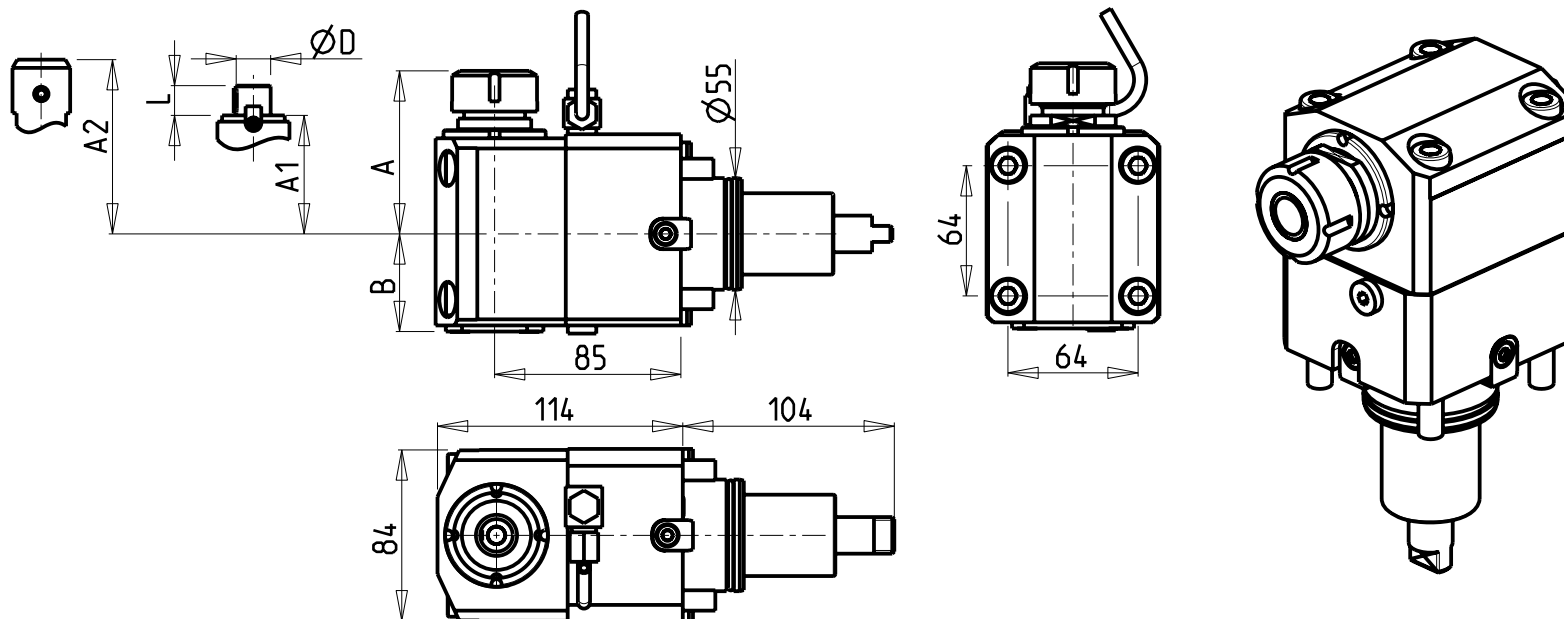

ATTENZIONE - ATTENTION - ACHTUNG

- VERIFICARE LE MISURE DI INGOMBRO PER POSSIBILE INTERFERENZA SU ALCUNI MODELLI DI MACCHINE
- Please check the overall sizes for possible interferences on some machine models
- Bitte überprüfen sie das ausmass um mögliche interferenzen auf einigen maschinen modellen zu vermeiden

- Chiave inclusa
- Key included
- Schluessel inbegriffen

Cod. MT	Mandrino Spindel Spindel	I	RPM	Coppia Max Max Torque Max Drehmoment	Reversibile lato mandrino/contromandrino Reversible sub/main spindle side Umkehrbare Spindelsete/Gegenspindelsete	Lubr.interna Coolant through Innenkuehlung	Lubr. esterna Ext. coolant Aussenkuehlung	A	A1	A2	B	D	L	CHIAVI NON INCLUDE Keys not included Schluessel nicht einbegriffen
DW 00020125	ER25	1:1	6000	50Nm	X		X	82.36	-	-	48	-	-	CHSTER25 CHUB36 o 0100000
DW 00020225	ER25	1:1	6000	50Nm	X	P=70bar	X	81.76	-	-	71.5	-	-	CHSTER25 CHUB36 o 0100000
DW 00020132	ER32	1:1	6000	50Nm	X		X	98.16	-	-	48	-	-	CHSTER32 CHUB36 o 0100000
DW 00020232	ER32	1:1	6000	50Nm	X	P=70bar	X	97.56	-	-	71.5	-	-	CHSTER32 CHUB36 o 0100000
DW 00020022	WELDON 20	1:1	6000	50Nm	X		X	-	-	100	48	-	-	
DW 00021617	Ø16x17	1:1	6000	50Nm	X		X	-	61	-	48	16	17	CH_VTCROCE_M08 • CHUB36 o 0100000
DW 00022219	Ø22x19	1:1	6000	50Nm	X		X	-	62	-	48	22	19	CH_VTCROCE_M10 • CHUB36 o 0100000
DW 00022240	Ø22x40	1:1	6000	50Nm	X		X	-	62	-	48	22	40	CH_VTCROCE_M10 • CHUB36 o 0100000
DW 00022721	Ø27x21	1:1	6000	50Nm	X		X	-	64	-	48	27	21	CH_VTCROCE_M12 • CHUB36 o 0100000
DW 00022733	Ø27x33	1:1	6000	50Nm	X		X	-	61	-	48	27	33	CH_VTCROCE_M12 • CHUB36 o 0100000
DW 00022750	Ø27x50	1:1	6000	50Nm	X		X	-	62.5	-	48	27	50	CH_VTCROCE_M12 • CHUB36 o 0100000

HW ACHEON  
CUTEX 160

MODULO MOTORIZZATO ASSIALE H=85mm  
Axial driven tool H=85mm  
Axial angetriebenes Werkzeug H=85mm

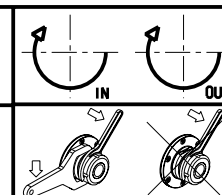

**M.T. srl**  
Via Casino Albini 480  
Tel. 0541/956034-957884  
Fax 0541/956341  
47842 S. GIOVANNI IN M. (RN)  
e-mail: mtma@mtmarchetti.com  
http://www.mtmarchetti.com

PRODUZIONE MODULI ROTANTI



PAGINA HW C 150-1-30

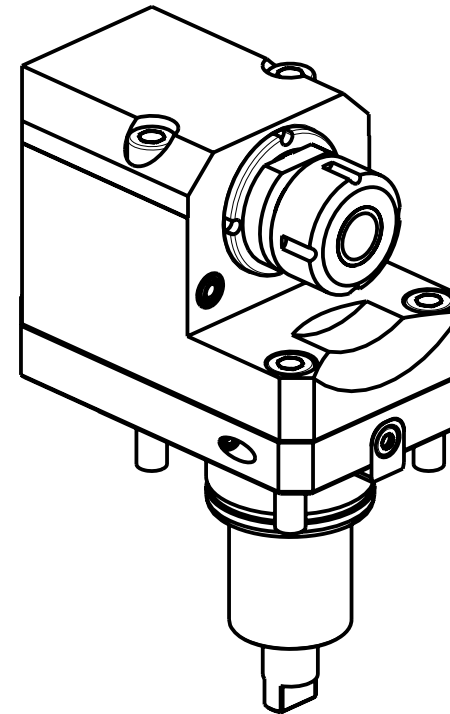
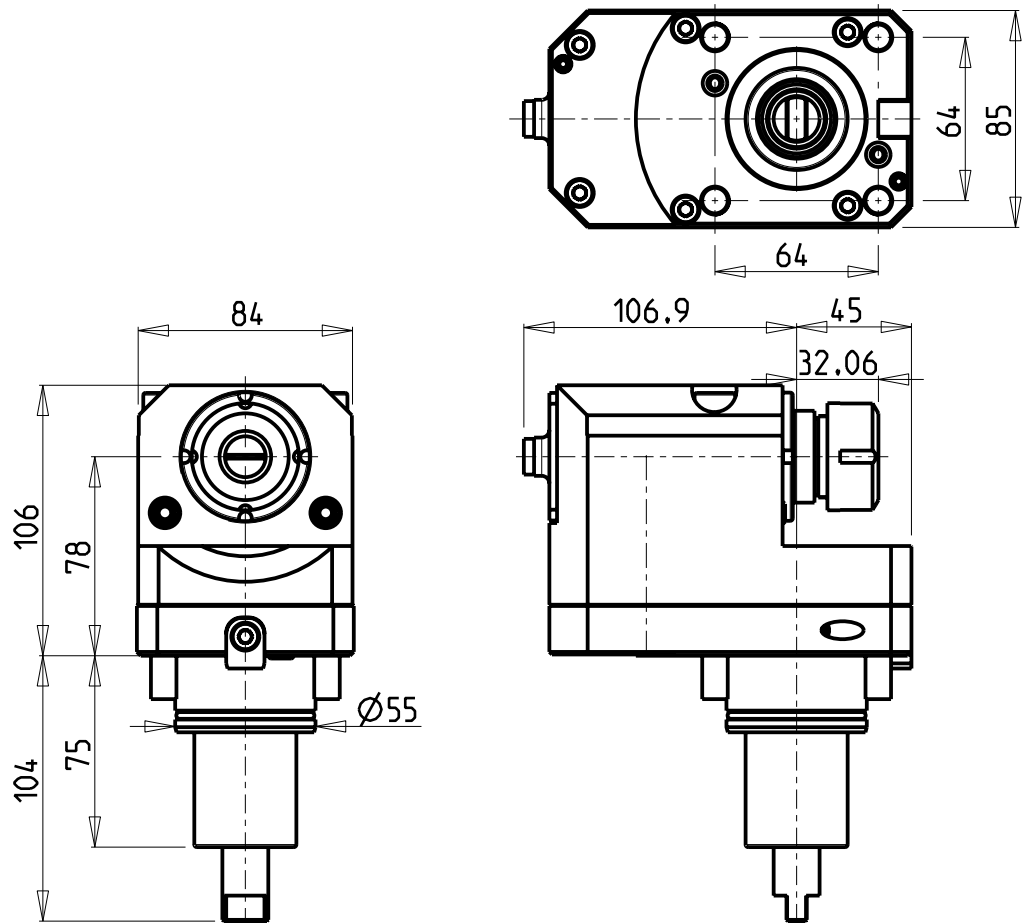

Cod. MT	Mandrino Spindle Spindel	I	RPM	Coppia Max Max Torque Max Drehmoment	Reversibile lato mandrino/contromandrino Reversible sub/main spindle side Umkehrbare Spindel-seite/ Gegenspindel-seite	Lubrificazione est. Ext. coolant Aussenkuehlung	CHIAVI NON INCLUSE Keys not included Schlüssel nicht einbegriffen	
0630025	ER25	1:1	6000	50Nm	X	X	CHSTER25	CHUB36

NEW

HW ACHEON  
CUTEX 160

MODULO MOTORIZZATO ASSIALE ARRETRATO  
Axial rear-set driven tool  
Axial angetriebenes Werkzeug zurueckversetzt

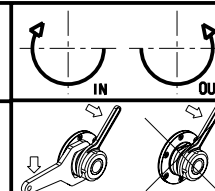

**M.T. srl**

Via Casino Albini 480  
Tel. 0541/956034-957884

Fax 0541/956341

47842 S. GIOVANNI IN M. (RN)

e-mail: mtma@mtmarchetti.com

http://www.mtmarchetti.com

PRODUZIONE MODULI ROTANTI



PAGINA HW C180-1-10

**ATTENZIONE - ATTENTION - ACHTUNG**

- VERIFICARE LE MISURE DI INGOMBRO PER POSSIBILE INTERFERENZA SU ALCUNI MODELLI DI MACCHINE
- Please check the overall sizes for possible interferences on some machine models
- Bitte überprüfen sie das ausmass um mögliche interferenzen auf einigen maschinen modellen zu vermeiden

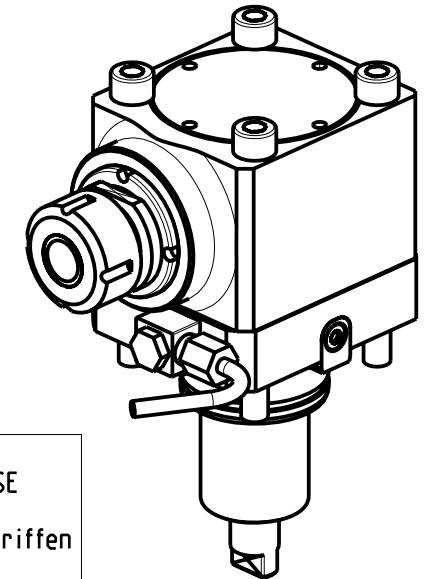
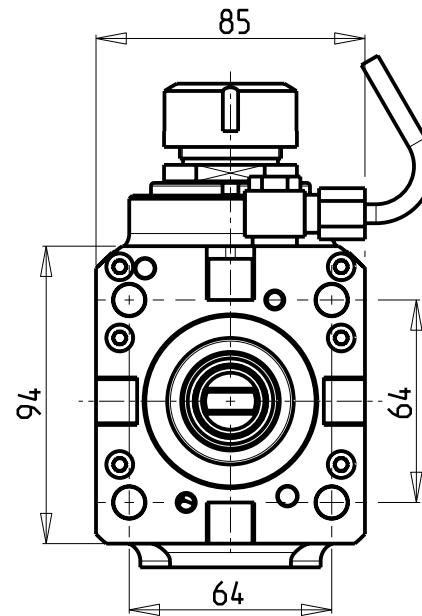
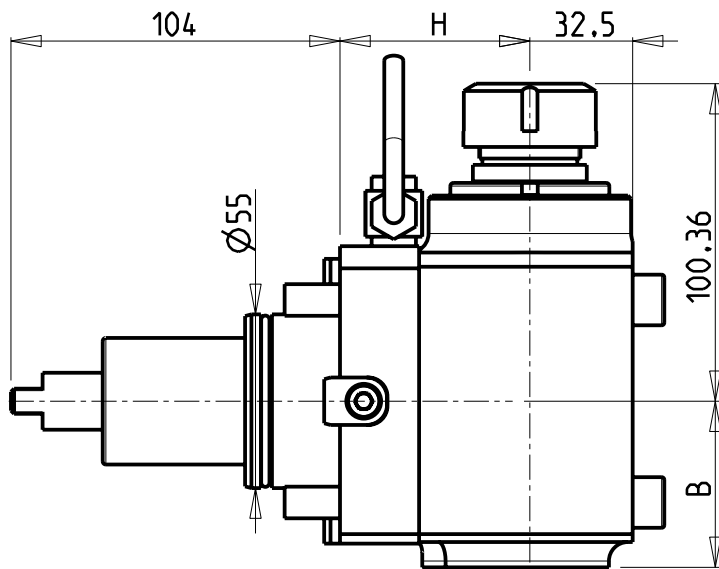

Cod. MT	Mandrino Spindle Spindel	I	RPM	Coppia Max Max Torque Max Drehmoment	Reversibile lato mandrino/controlmandrino Reversible sub/main spindle side Umkehrbare Spindel-seite/ Gegenspindel-seite	Lubrificazione int. Coolant through Innenkuehlung	Lubrificazione est. Ext. coolant Aussenkuehlung	H	B	CHIAVI NON INCLUSE Keys not included Schlüssel nicht einbegriffen	
0891225	ER25	1:2	12000	30Nm	X		X	60	52.5	CHSTER25	CHUB36
0891325	ER25	1:2	12000	30Nm	X	P=70bar	X	60	79	CHSTER25	CHUB36
0893625	ER25	1:2	12000	30Nm	X		X	70	52.5	CHSTER25	CHUB36
0893725	ER25	1:2	12000	30Nm	X	P=70bar	X	70	79	CHSTER25	CHUB36
0892425	ER25	1:2	12000	30Nm	X		X	85	52.5	CHSTER25	CHUB36
0892525	ER25	1:2	12000	30Nm	X	P=70bar	X	85	79	CHSTER25	CHUB36

NEW  
NEW  
NEW  
NEW  
NEW  
NEW

HW ACHEON  
CUTEX 160

MODULO MOTORIZZATO ASSIALE MOLTIPLICATO I=1:2  
Axial geared-up I=1:2 driven tool  
Axial angetriebenes Werkzeug uebersetzt I=1:2

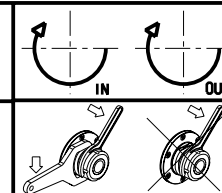

**M.T. srl**

Via Casino Albini 480  
Tel. 0541/956034-957884  
Fax 0541/956341

47842 S. GIOVANNI IN M. (RN)  
e-mail: mtma@mtmarchetti.com  
http://www.mtmarchetti.com

PRODUZIONE MODULI ROTANTI



PAGINA HW C200-1-10

**ATTENZIONE - ATTENTION - ACHTUNG**

- VERIFICARE LE MISURE DI INGOMBRO PER POSSIBILE INTERFERENZA SU ALCUNI MODELLI DI MACCHINE
- Please check the overall sizes for possible interferences on some machine models
- Bitte überprüfen sie das ausmass um mögliche interferenzen auf einigen maschinen modellen zu vermeiden

**ATTENZIONE - ATTENTION - ACHTUNG**

- PRIMA DI UTILIZZARE IL MOTORIZZATO CONSULTARE LE ISTRUZIONI ALLEGATE!
- BEFORE USING THE DRIVEN TOOL, PLEASE CHECK THE ENCLOSED INSTRUCTION SHEET!
- VOR DER BENUTZUNG DES ANGETRIEBENEN WERKZEUGES, DIE BEILIEGENDEN INSTRUKTIONEN DURCHLESEN!

**ATTENZIONE - ATTENTION - ACHTUNG**

- Per lo smontaggio degli utensili utilizzare sempre la chiave di contrasto come indicato nel manuale d'uso.
- For disassembly of the tools use always the contrast key as mentioned in the user instructions.
- Fuer das Abmontieren der Werkzeuge immer den Gegenschlüssel benutzen wie in der Bedienungsanleitung erwäehnt.

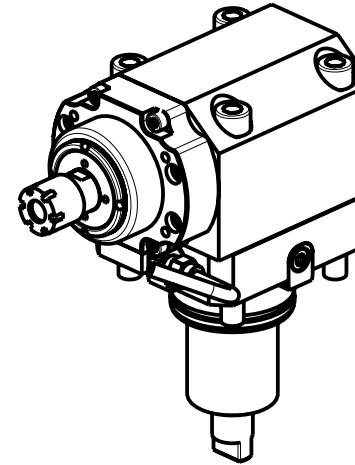
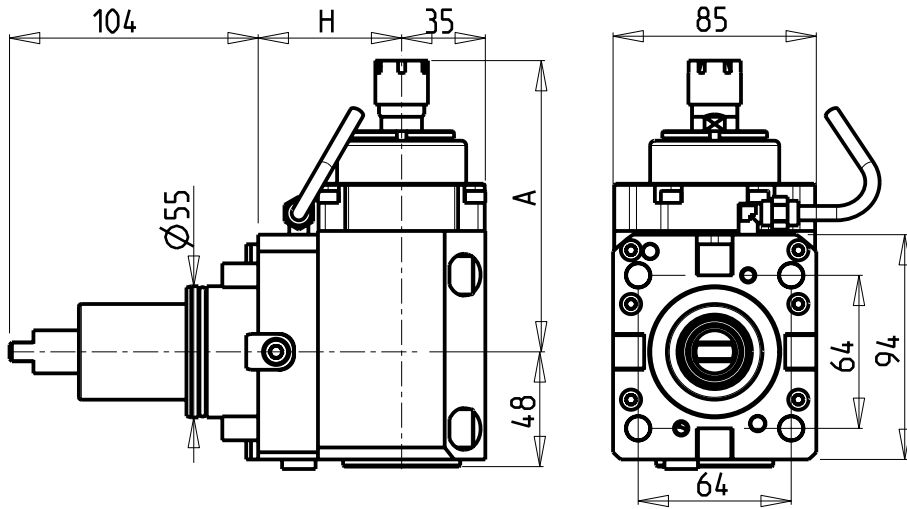

Cod. MT	Mandrino Spindle Spindel	I	RPM MAX	Coppia Max Max Torque Max Drehmoment	Reversibile lato mandrino/contromandrino Reversible sub/main spindle side Umkehrbare Spindel-seite/ Gegenspindel-seite	Lubrificazione int. Coolant through Innenkuehlung	Lubrificazione est. Ext. coolant Aussenkuehlung	A	H	CHIAVI INCLUSE Keys included Schluessel einbegriffen		
DW 00190116	ER16	1:5.625	22500	6Nm	X		X	121.8	60	CHMNER16	CHUB17	NEW
DW 00190111	ER11	1:5.625	22500	6Nm	X	P=30bar		134	60	CHMNER11	CHUB11	NEW
DW 00190316	ER16	1:5.625	22500	6Nm	X		X	121.8	70	CHMNER16	CHUB17	NEW
DW 00190311	ER11	1:5.625	22500	6Nm	X	P=30bar		134	70	CHMNER11	CHUB11	NEW
DW 00190216	ER16	1:5.625	22500	6Nm	X		X	121.8	85	CHMNER16	CHUB17	NEW
DW 00190211	ER11	1:5.625	22500	6Nm	X	P=30bar		134	85	CHMNER11	CHUB11	NEW

HW ACHEON  
CUTEX 160

MODULO MOTORIZZATO ASSIALE MOLTIPLICATO I=1:5.625  
Axial geared-up I=1:5.625 driven tool  
Axial angetriebenes Werkzeug uebersetzt I=1:5.625

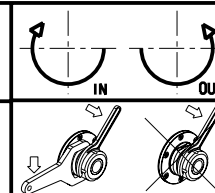

**M.T. srl**

Via Casino Albini 480  
Tel. 0541/956034-957884  
Fax 0541/956341  
47842 S. GIOVANNI IN M. (RN)  
e-mail: mtma@mtmarchetti.com  
http://www.mtmarchetti.com

PRODUZIONE MODULI ROTANTI



PAGINA HW C 210-1-10

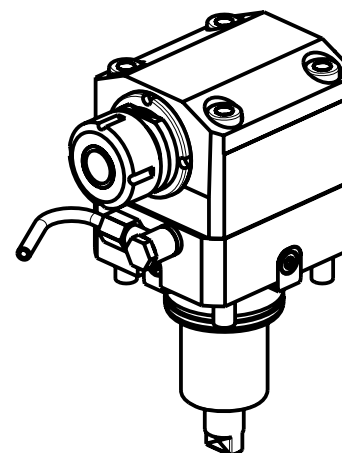
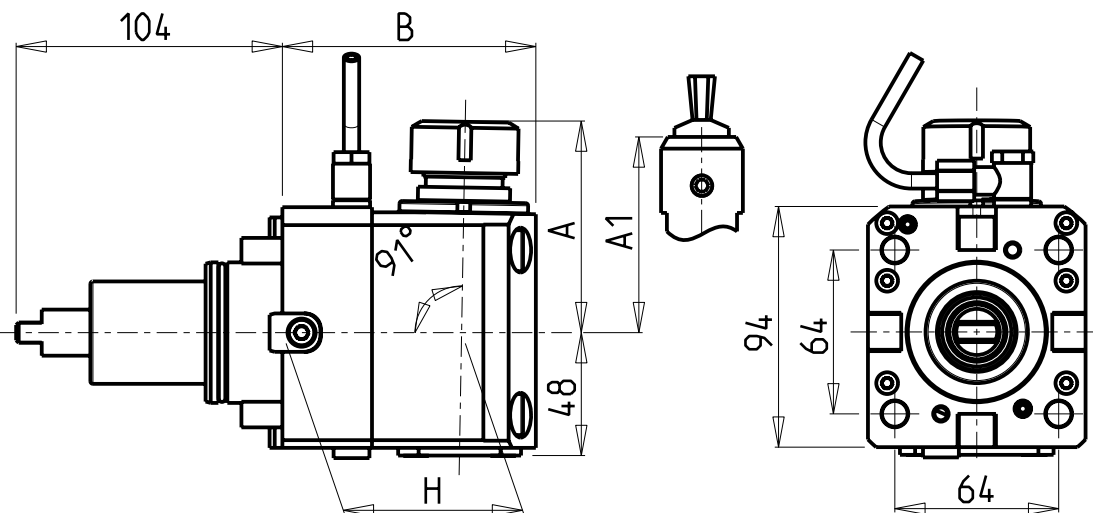

**ATTENZIONE - ATTENTION - ACHTUNG**

- VERIFICARE LE MISURE DI INGOMBRO PER POSSIBILE INTERFERENZA SU ALCUNI MODELLI DI MACCHINE
- Please check the overall sizes for possible interferences on some machine models
- Bitte überprüfen sie das ausmass um mögliche interferenzen auf einigen maschinen modellen zu vermeiden

Cod. MT	Mandrino Spindle Spindel	I	RPM	Coppia Max Max Torque Max Drehmoment	Reversibile lato mandrino/contromandrino Reversible sub/main spindle side Umkehrbare Spindel-seite/ Gegenspindel-seite	Lubrificazione est. Ext. coolant Aussenkuehlung	A	A1	B	H	CHIAVI NON INCLUSE Keys not included Schluessel nicht einbegriffen		
0319125	ER25	1:1	6000	50Nm	X	X	82.35	-	89	60	CHSTER25	CHUB36 o 0100000	NEW
0319108	WELDON 8	1:1	6000	50Nm	X	X	-	76.5	89	60			NEW
0319110	WELDON 10	1:1	6000	50Nm	X	X	-	76.5	89	60			NEW
0319112	WELDON 12	1:1	6000	50Nm	X	X	-	76.5	89	60			NEW
0319116	WELDON 16	1:1	6000	50Nm	X	X	-	73.5	89	60			NEW
DW 00249125	ER25	1:1	6000	50Nm	X	X	82.35	-	99	70	CHSTER25	CHUB36 o 0100000	NEW
DW 00249108	WELDON 8	1:1	6000	50Nm	X	X	-	76.5	99	70			NEW
DW 00249110	WELDON 10	1:1	6000	50Nm	X	X	-	76.5	99	70			NEW
DW 00249112	WELDON 12	1:1	6000	50Nm	X	X	-	76.5	99	70			NEW
DW 00249116	WELDON 16	1:1	6000	50Nm	X	X	-	76.5	99	70			NEW
DW 00029125	ER25	1:1	6000	50Nm	X	X	82.35	-	114	85	CHSTER25	CHUB36 o 0100000	NEW
DW 00029108	WELDON 8	1:1	6000	50Nm	X	X	-	76.5	114	85			NEW
DW 00029110	WELDON 10	1:1	6000	50Nm	X	X	-	76.5	114	85			NEW
DW 00029112	WELDON 12	1:1	6000	50Nm	X	X	-	76.5	114	85			NEW
DW 00029116	WELDON 16	1:1	6000	50Nm	X	X	-	73.5	114	85			NEW

HW ACHEON  
CUTEX 160

MODULO MOTORIZZATO ASSIALE PER POLIGONATURA INTERNA  
Axial driven tool for internal polygon-making  
Axial angetriebenes Werkzeug fuer interne Facettierung

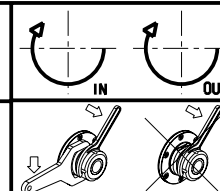

**M.T. srl**

Via Casino Albini 480  
Tel. 0541/956034-957884  
Fax 0541/956341  
47842 S. GIOVANNI IN M. (RN)  
e-mail: mtma@mtmarchetti.com  
http://www.mtmarchetti.com

PRODUZIONE MODULI ROTANTI

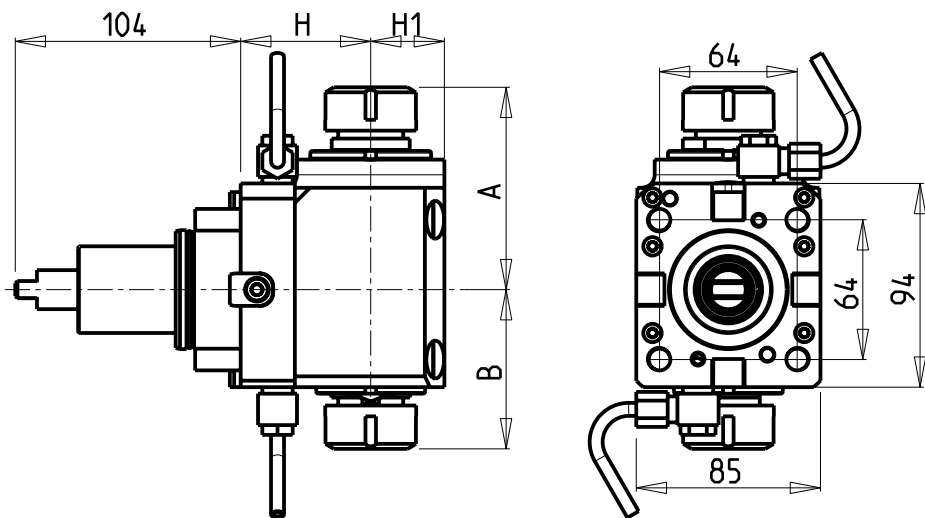

PAGINA HW C230-1-10

**ATTENZIONE - ATTENTION - ACHTUNG**

- VERIFICARE LE MISURE DI INGOMBRO PER POSSIBILE INTERFERENZA SU ALCUNI MODELLI DI MACCHINE
- Please check the overall sizes for possible interferences on some machine models
- Bitte überprüfen sie das ausmass um mögliche interferenzen auf einigen maschinen modellen zu vermeiden

**ATTENZIONE - ATTENTION - ACHTUNG**

- Per lo smontaggio degli utensili utilizzare sempre la chiave di contrasto come indicato nel manuale d'uso.
- For disassembly of the tools use always the contrast key as mentioned in the user instructions.
- Fuer das Abmontieren der Werkzeuge immer den Gegenschlüssel benutzen wie in der Bedienungsanleitung erwäehnt.

Cod. MT	Mandrino Spindel Spindel	I	RPM	Coppia Max Max Torque Max Drehmoment	Reversibile lato mandrino/contromandrino Reversible sub/main spindle side Umkehrbare Spindel-seite/ Gegenspindel-seite	Lubrificazione est. Ext. coolant Aussenkuehlung	A	B	H	H1	CHIAVI NON INCLUSE Keys not included Schlüssel nicht einbegriffen		
DW 00080132	ER32+ER32	1:1	6000	50Nm	X	X	100.56	78.96	60	34	CHSTER32	CHUB36 o 0100000	NEW
DW 00080332	ER32+ER32	1:1	6000	50Nm	X	X	100.56	78.96	70	34	CHSTER32	CHUB36 o 0100000	NEW
DW 00080232	ER32+ER32	1:1	6000	50Nm	X	X	100.56	78.96	85	34	CHSTER32	CHUB36 o 0100000	NEW
DW 00080125	ER25+ER25	1:1	6000	50Nm	X	X	93.36	73.46	60	34	CHSTER25	CHUB36+CHUB29	NEW
DW 00080325	ER25+ER25	1:1	6000	50Nm	X	X	93.36	73.46	70	34	CHSTER25	CHUB36+CHUB29	NEW
DW 00080225	ER25+ER25	1:1	6000	50Nm	X	X	93.36	73.46	85	34	CHSTER25	CHUB36+CHUB29	NEW
0311625	ER25+ER16	1:1	6000	50Nm	X	X	81.86	66	60	29	CHMNER16+CHSTER25	CHUB36 o 0100000	NEW
DW 00242516	ER25+ER16	1:1	6000	50Nm	X	X	81.86	66	70	29	CHMNER16+CHSTER25	CHUB36 o 0100000	NEW
DW 00022516	ER25+ER16	1:1	6000	50Nm	X	X	81.86	66	85	29	CHMNER16+CHSTER25	CHUB36 o 0100000	NEW
0311616	ER16+ER16	1:1	6000	50Nm	X	X	81.2	66	60	29	CHMNER16	CHUB36 o 0100000	NEW
DW 00241616	ER16+ER16	1:1	6000	50Nm	X	X	81.2	66	70	29	CHMNER16	CHUB36 o 0100000	NEW
DW 00021616	ER16+ER16	1:1	6000	50Nm	X	X	81.2	66	85	29	CHMNER16	CHUB36 o 0100000	NEW

HW ACHEON  
CUTEX 160

MODULO MOTORIZZATO ASSIALE BISPORGENTE  
Axial opposite face twin driven tool  
Axial angetriebenes Werkzeug halb vorspringend

**M.T. srl**

Via Casino Albini 480  
Tel. 0541/956034-957884  
Fax 0541/956341  
47842 S. GIOVANNI IN M. (RN)  
e-mail: mtma@mtmarchetti.com  
http://www.mtmarchetti.com

PRODUZIONE MODULI ROTANTI



PAGINA HW C240-1-10

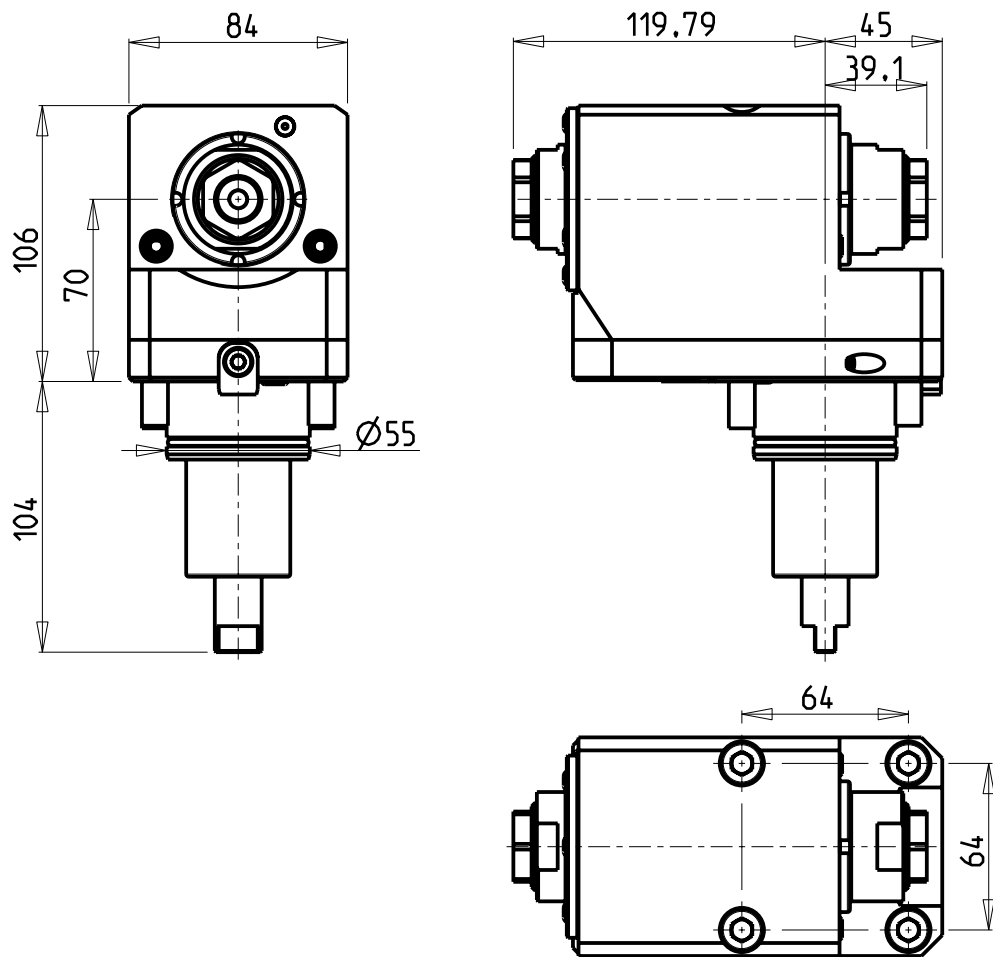

### ATTENZIONE - ATTENTION - ACHTUNG

- Per lo smontaggio degli utensili utilizzare sempre la chiave di contrasto come indicato nel manuale d'uso.
- For disassembly of the tools use always the contrast key as mentioned in the user instructions.
- Fuer das Abmontieren der Werkzeuge immer den Gegenschlüssel benutzen wie in der Bedienungsanleitung erwaeht.

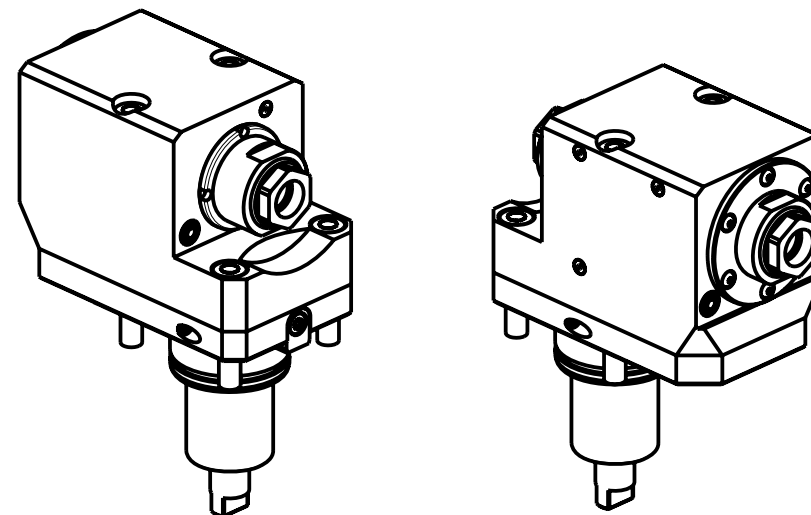

Cod. MT	Mandrino Spindle Spindel	I	RPM	Coppia Max Max Torque Max Drehmoment	Reversibile lato mandrino/contromandrino Reversible sub/main spindle side Umkehrbare Spindel-seite/ Gegenspindel-seite	Lubrificazione est. Ext. coolant Aussenkuehlung	CHIAVI NON INCLUSE Keys not included Schluesel nicht inbegriffen		NEW
							CHUB27	CHUB38	
0632525	ERA25+ERA25	1:1	6000	50Nm	X	X	CHUB27	CHUB38	

HW ACHEON  
CUTEX 160

MODULO MOTORIZZATO ASSIALE ARRETRATO BISPORGENTE

Axial opposite face rear-set driven tool

Axial angetriebenes Werkzeug zurueckversetzt halb vorspringend

**M.T. srl**

Via Casino Albini 480  
Tel. 0541/956034-957884  
Fax 0541/956341  
47842 S. GIOVANNI IN M. (RN)  
e-mail: mtma@mtmarchetti.com  
http://www.mtmarchetti.com

PRODUZIONE MODULI ROTANTI



PAGINA HW C 243-1-10



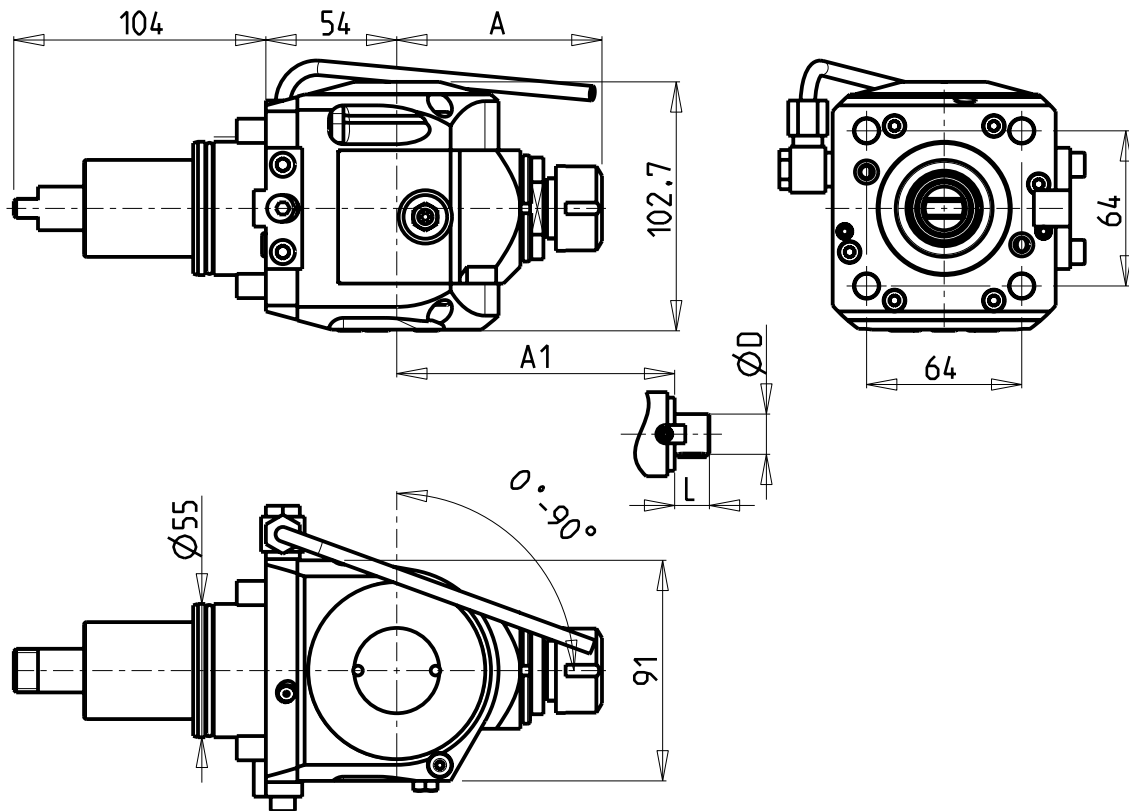

### ATTENZIONE - ATTENTION - ACHTUNG

- VERIFICARE LE MISURE DI INGOMBRO PER POSSIBILE INTERFERENZA SU ALCUNI MODELLI DI MACCHINE
- Please check the overall sizes for possible interferences on some machine models
- Bitte überprüfen sie das ausmass um mögliche interferenzen auf einigen maschinen modellen zu vermeiden

Cod. MT	Mandrino Spindle Spindel	I	RPM	Coppia Max Max Torque Max Drehmoment	Reversibile lato mandrino/contromandrino Reversible sub/main spindle side Umkehrbare Spindel-seite/ Gegenspindel-seite	Lubrificazione est. Ext. coolant Aussenkuehlung	A	A1	D	L	CHIAVI INCLUSE Keys included Schluessel inbegriffen			
											CHSTER20	CHUB36	CHESL08	
0360020	ER20	1:1	6000	40Nm	X	X	84.16	-	-	-	CHSTER20	CHUB36	CHESL08	NEW
0360025	ER25	1:1	6000	40Nm	X	X	85.66	-	-	-	CHSTER25	CHUB36	CHESL08	NEW
0361617	Ø16x17	1:1	6000	40Nm	X	X	-	65	16	17	CH_VTCROCE_M08	CHUB36	CHESL08	NEW
0362219	Ø22x19	1:1	6000	40Nm	X	X	-	66	22	19	CH_VTCROCE_M10	CHUB36	CHESL08	NEW
0361905	Ø3/4"x3/4"	1:1	6000	40Nm	X	X	-	65	3/4"	3/4"	CH_VTCROCE_M08	CHUB36	CHESL08	NEW

HW ACHEON  
CUTEX 160

MODULO MOTORIZZATO ORIENTABILE 0-90°  
0-90° adjustable angle driven tool  
Angetriebenes Werkzeug schwenkbar 0-90°

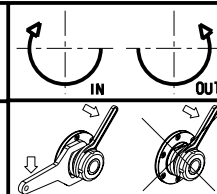

**M.T. srl**

Via Casino Albini 480  
Tel. 0541/956034-957884  
Fax 0541/956341

47842 S. GIOVANNI IN M. (RN)  
e-mail: mtma@mtmarchetti.com  
http://www.mtmarchetti.com

PRODUZIONE MODULI ROTANTI



PAGINA HW C 330-1-00

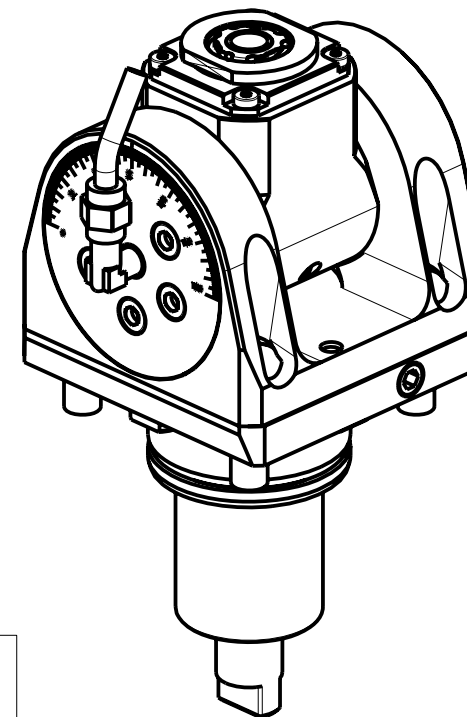
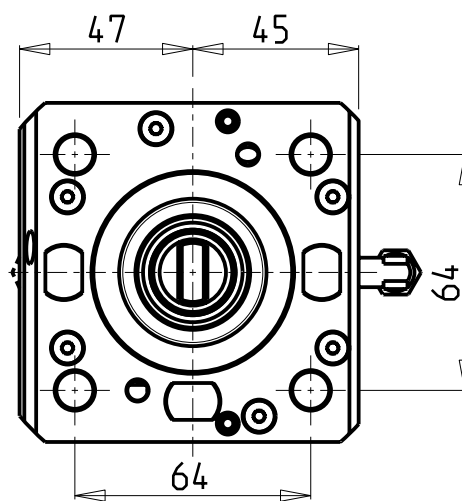
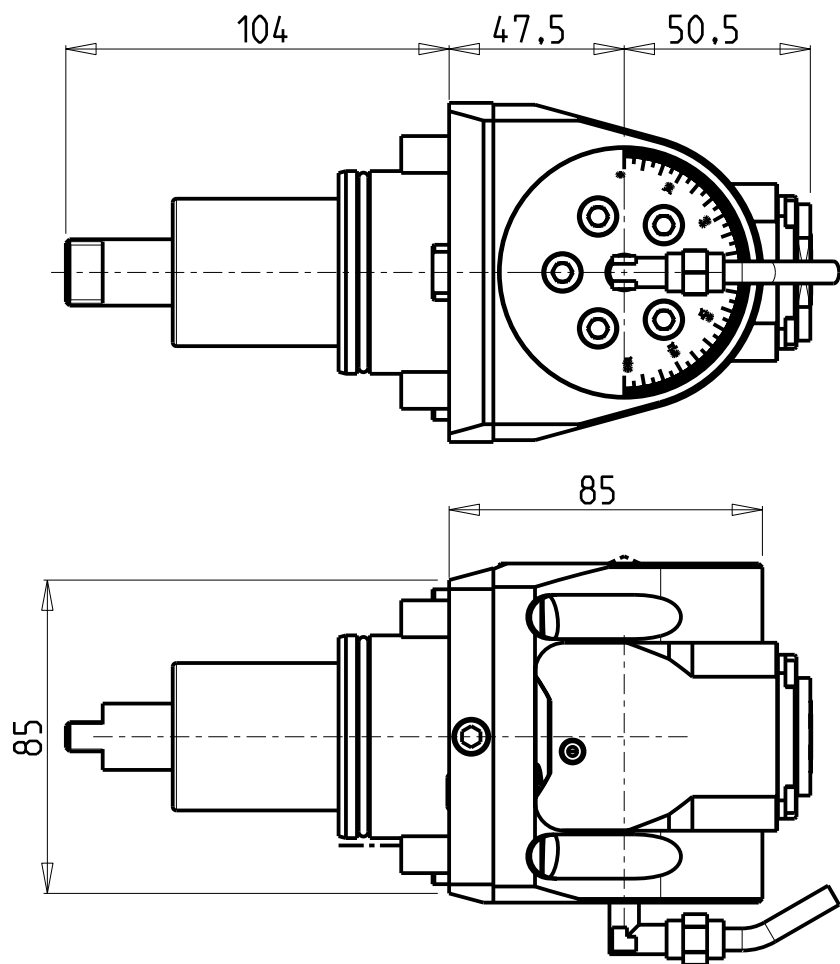

Cod. MT	Mandrino Spindle Spindel	I	RPM	Coppia Max Max Torque Max Drehmoment	Lubrificazione int. Coolant through Innenkuehlung	Lubrificazione est. Ext. coolant Aussenkuehlung	CHIAVI INCLUSE Keys included Schluesssel inbegriffen				
							CHUB22	CHUB36	CHTAER20ZC	CHESL07	
DW 00660120	ERA20	1:1	6000	30Nm		X	CHUB22	CHUB36	CHTAER20ZC	CHESL07	NEW
DW 00660220	ERA20	1:1	6000	30Nm	P=70bar	X	CHUB22	CHUB36	CHTAER20ZC	CHESL07	NEW

HW ACHEON  
CUTEX 160

MODULO MOTORIZZATO ORIENTABILE  $\pm 90^\circ$  H=47.5mm  
 $\pm 90^\circ$  adjustable angle driven tool H=47.5mm  
 Angetriebenes Werkzeug schwenkbar  $\pm 90^\circ$  H=47.5mm

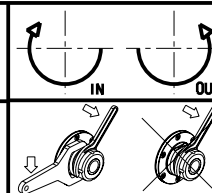

**M.T. srl**

Via Casino Albini 480  
Tel. 0541/956034-957884  
Fax 0541/956341

47842 S. GIOVANNI IN M. (RN)  
e-mail: mtma@mtmarchetti.com  
http://www.mtmarchetti.com

PRODUZIONE MODULI ROTANTI



PAGINA HW C 335-1-00

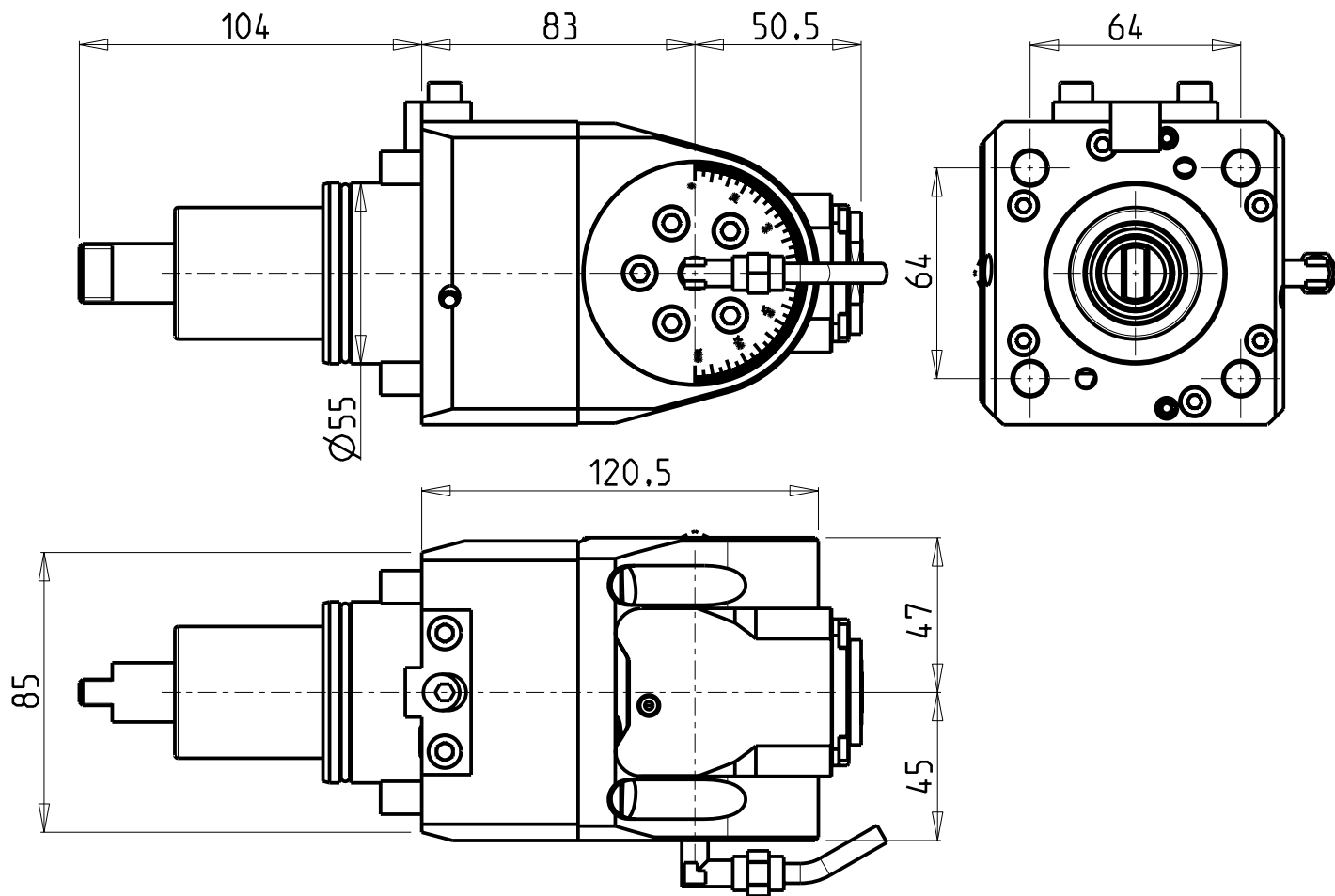

**ATTENZIONE - ATTENTION - ACHTUNG**

- VERIFICARE LE MISURE DI INGOMBRO PER POSSIBILE INTERFERENZA SU ALCUNI MODELLI DI MACCHINE
- Please check the overall sizes for possible interferences on some machine models
- Bitte überprüfen sie das ausmass um mögliche interferenzen auf einigen maschinen modellen zu vermeiden

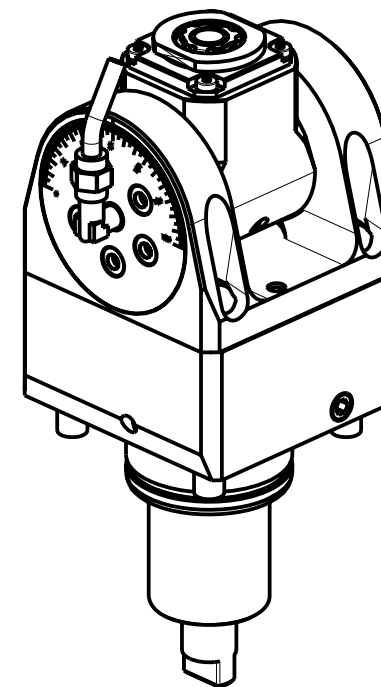

Cod. MT	Mandrino Spindle Spindel	I	RPM	Coppia Max Max Torque Max Drehmoment	Lubrificazione int. Coolant through Innenkuehlung	Lubrificazione est. Ext. coolant Aussenkuehlung	CHIAVI INCLUSE Keys included Schlüssel inbegriffen				
DW 00661120	ERA20	1:1	6000	30Nm		X	CHUB22	CHUB36	CHTAER20ZC	CHESL08	NEW
DW 00661220	ERA20	1:1	6000	30Nm	P=70bar	X	CHUB22	CHUB36	CHTAER20ZC	CHESL08	NEW

HW ACHEON  
CUTEX 160

MODULO MOTORIZZATO ORIENTABILE ±90° H=83mm  
±90° adjustable angle driven tool H=83mm  
Angetriebenes Werkzeug schwenkbar ±90° H=83mm

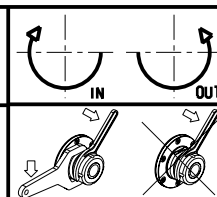

**M.T. srl**  
Via Casino Albini 480  
Tel. 0541/956034-957884  
Fax 0541/956341  
47842 S. GIOVANNI IN M. (RN)  
e-mail: mtma@mtmarchetti.com  
http://www.mtmarchetti.com

PRODUZIONE MODULI ROTANTI



PAGINA HW C335-1-10

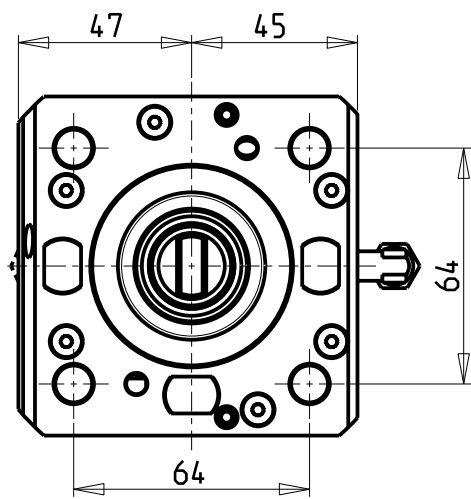
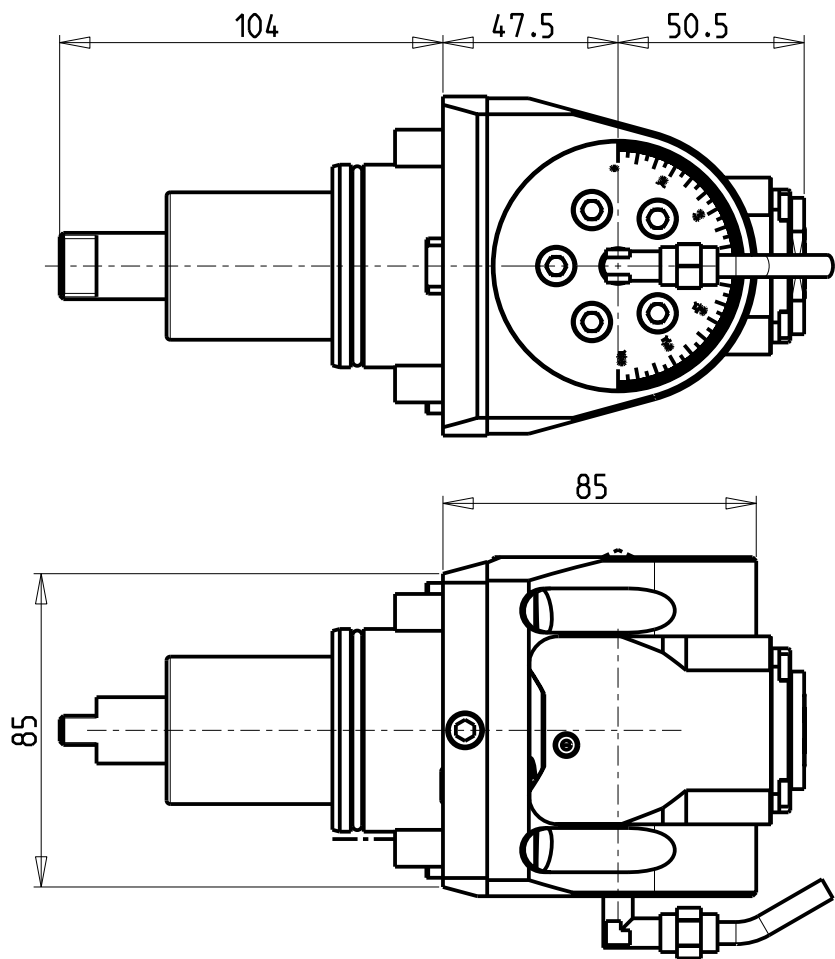

**ATTENZIONE - ATTENTION - ACHTUNG**

- Per lo smontaggio degli utensili utilizzare sempre la chiave di contrasto come indicato nel manuale d'uso.
- For disassembly of the tools use always the contrast key as mentioned in the user instructions.
- Fuer das Abmontieren der Werkzeuge immer den Gegenschlüssel benutzen wie in der Bedienungsanleitung erwäehnt.

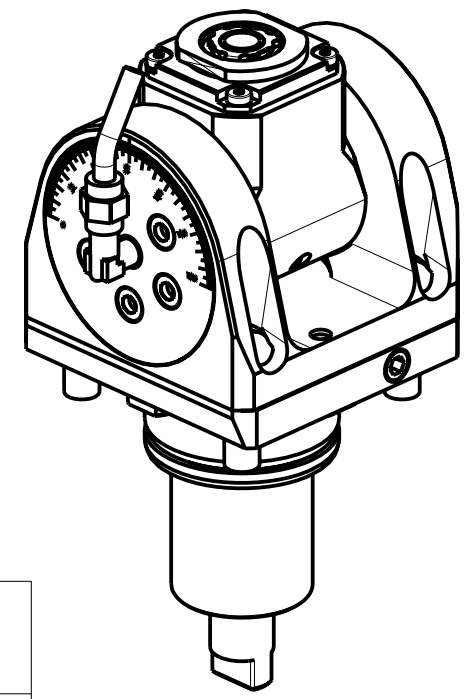

Cod. MT	Mandrino Spindle Spindel	I	RPM	Coppia Max Max Torque Max Drehmoment	Lubrificazione int. Coolant through Innenkuehlung	Lubrificazione est. Ext. coolant Aussenkuehlung	CHIAVI INCLUSE Keys included Schluesssel inbegriffen				
DW 00660316	ERA16	1:2	12000	8Nm		X	CHUB19_SP3	CHUB32	CHTAER16ZC	CHESL07	NEW
DW 00660416	ERA16	1:2	12000	8Nm	P=70bar	X	CHUB19_SP3	CHUB32	CHTAER16ZC	CHESL07	NEW

**HW ACEON  
CUTEX 160**

MODULO MOTORIZZATO ORIENTABILE +/-90° MOLTIPLICATO I=1:2 H=47.5mm  
 +/-90° adjustable angle driven tool geared-up I=1:2 H=47.5mm  
 Angetriebenes Werkzeug schwenkbar +/-90° uebersetzt I=1:2 H=47.5mm

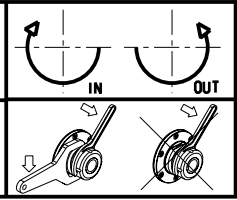

**M.T. srl**  
 Via Casino Albini 480  
 Tel. 0541/956034-957884  
 Fax 0541/956341  
 47842 S. GIOVANNI IN M. (RN)  
 e-mail: mtma@mtmarchetti.com  
 http://www.mtmarchetti.com

PRODUZIONE MODULI ROTANTI

PAGINA HW C 336-1-00

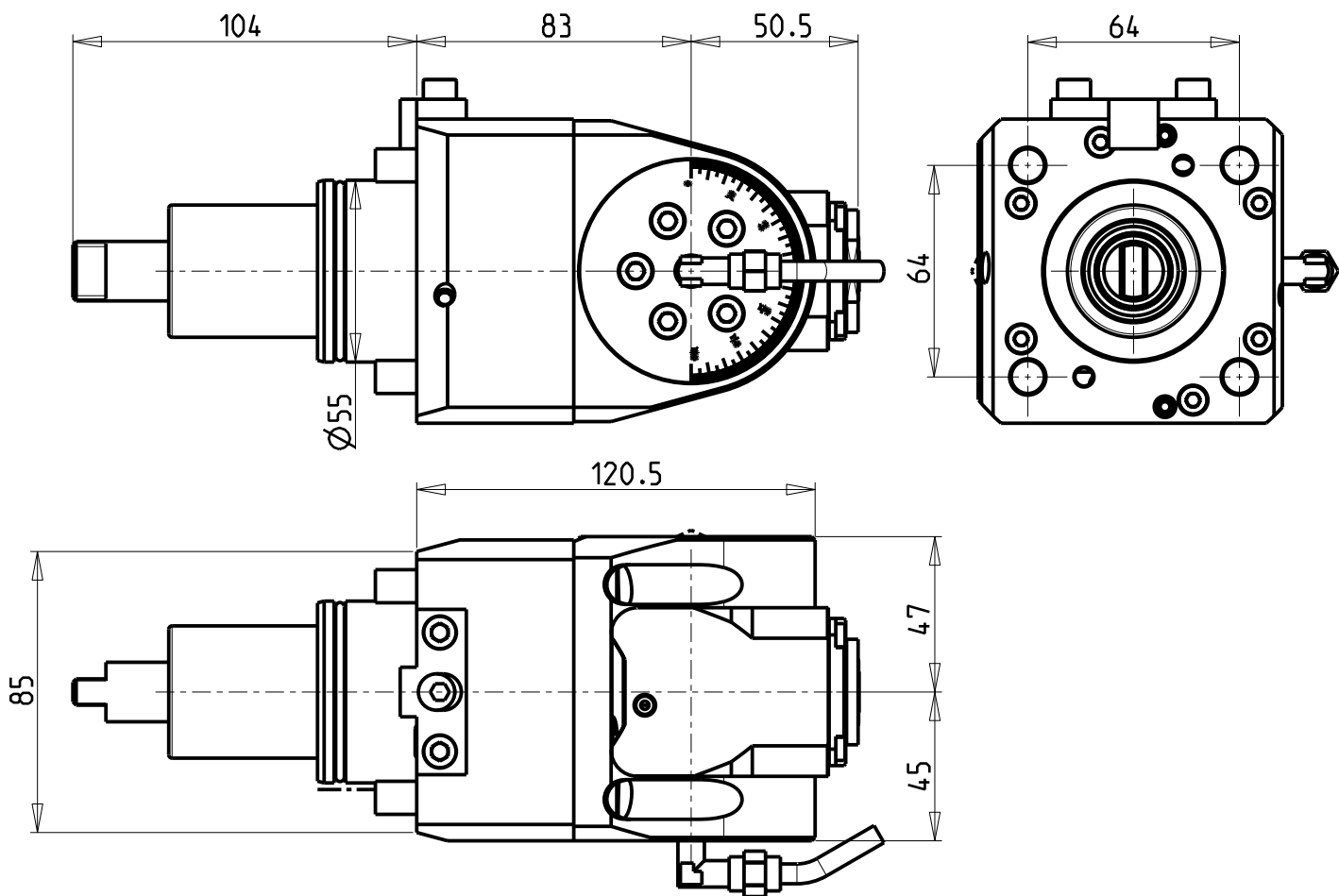

**ATTENZIONE - ATTENTION - ACHTUNG**

- Per lo smontaggio degli utensili utilizzare sempre la chiave di contrasto come indicato nel manuale d'uso.
- For disassembly of the tools use always the contrast key as mentioned in the user instructions.
- Fuer das Abmontieren der Werkzeuge immer den Gegenschlüssel benutzen wie in der Bedienungsanleitung erwahnt.

**ATTENZIONE - ATTENTION - ACHTUNG**

- VERIFICARE LE MISURE DI INGOMBRO PER POSSIBILE INTERFERENZA SU ALCUNI MODELLI DI MACCHINE
- Please check the overall sizes for possible interferences on some machine models
- Bitte überprüfen sie das ausmass um mögliche interferenzen auf einigen maschinen modellen zu vermeiden

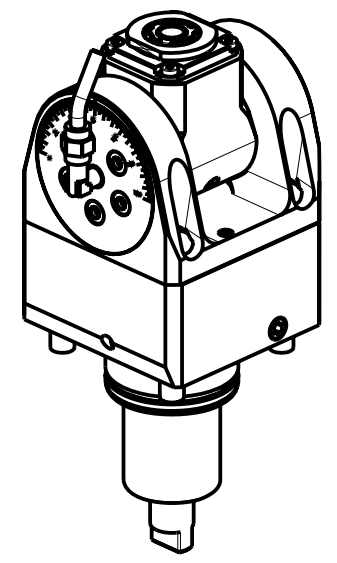

Cod. MT	Mandrino Spindle Spindel	I	RPM	Coppia Max Max Torque Max Drehmoment	Lubrificazione int. Coolant through Innenkuehlung	Lubrificazione est. Ext. coolant Aussenkuehlung	CHIAVI INCLUSE Keys included Schlüssel inbegriffen				
DW 00661316	ERA16	1:2	12000	8Nm		X	CHUB19_SP3	CHUB32	CHTAER16ZC	CHESL08	NEW
DW 00661416	ERA16	1:2	12000	8Nm	P=70bar	X	CHUB19_SP3	CHUB32	CHTAER16ZC	CHESL08	NEW

**HW ACHEON  
CUTEX 160**

MODULO MOTORIZZATO ORIENTABILE +/-90° MOLTIPLICATO I=1:2 H=83mm  
 +/-90° adjustable angle driven tool geared-up I=1:2 H=83mm  
 Angetriebenes Werkzeug schwenkbar +/-90° uebersetzt I=1:2 H=83mm

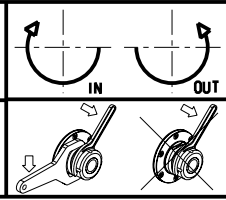

**M.T. srl**  
 Via Casino Albini 480  
 Tel. 0541/956034-957884  
 Fax 0541/956341  
 47842 S. GIOVANNI IN M. (RN)  
 e-mail: mtma@mtmarchetti.com  
 http://www.mtmarchetti.com

PRODUZIONE MODULI ROTANTI

PAGINA HW C336-1-10

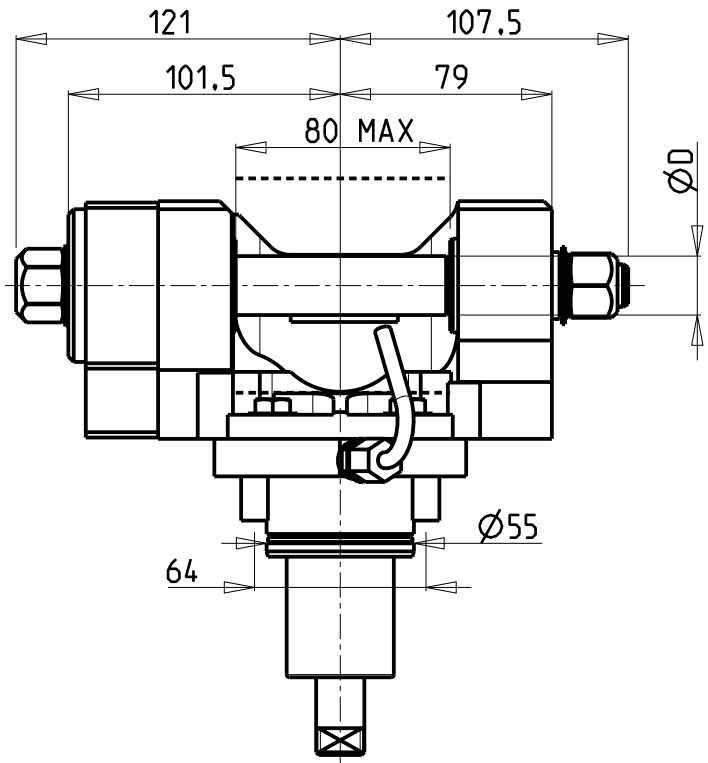
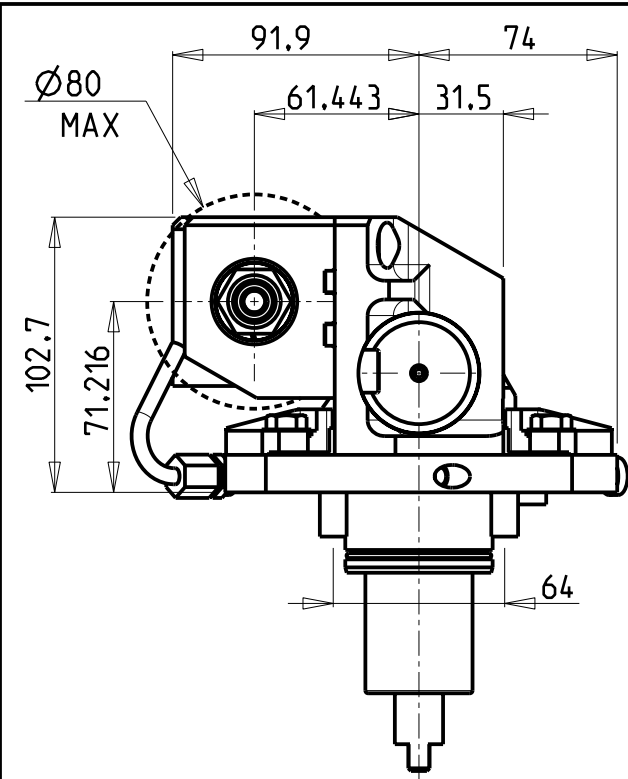

INCLINAZIONE  
REGOLABILE ±20°

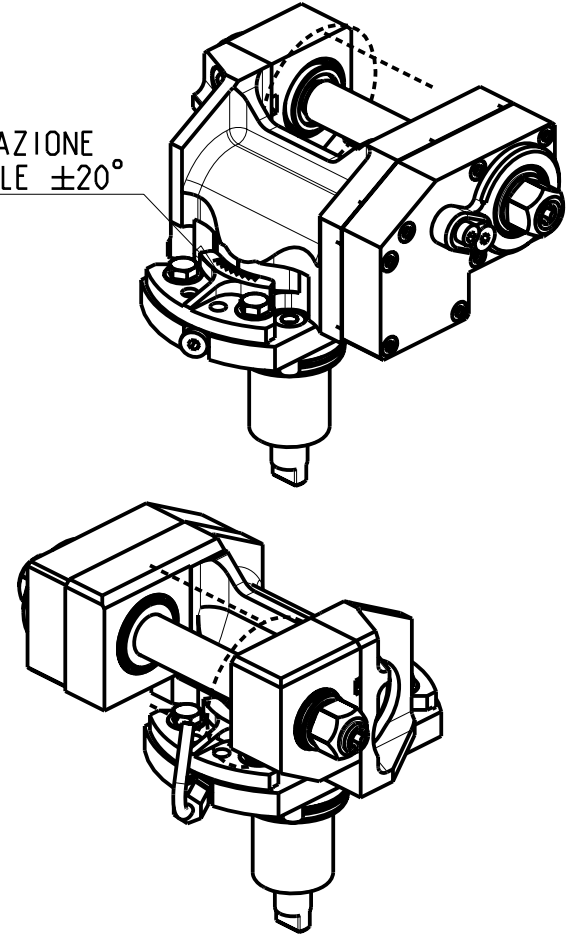

**DOTAZIONI - SUPPLIED WITH - AUSSTATTUNG**

mm / inch	- N°1 ALBERO + DISTANZIALI - N°1 SHAFT + SPACER - N°1 DORN + ABSTANDSSTUECK
-----------	---

PER ALBERI E DISTANZIALI VEDI PAG. TBL250-1-00  
FOR SHAFT END SPACER SEE PAGE TBL250-1-00  
FUER DORN UND ABSTANDSSTUECK SEITE TBL250-1-00

Cod. MT	I	RPM max	Coppia Max Max Torque Max Drehmoment	Reversibile lato mandrino/contromandrino Reversible sub/main spindle side Umkehrbare Spindel-seite/ Gegenspindel-seite	Lubrificazione est. Ext. coolant Aussenkuehlung	D		CHIAVI INCLUSE Keys included Schlüssel inbegriffen		
						(mm)	(Inch)	CHUB24	CHUB13	CHESL08
0621100	1:1	6000	60Nm	X	X	16-22-27-32	3/4"-1"-1 1/4"	CHUB24	CHUB13	CHESL08
0622100	2:1	3000	80Nm	X	X	16-22-27-32	3/4"-1"-1 1/4"	CHUB24	CHUB13	CHESL08

NEW  
NEW

**ATTENZIONE - ATTENTION - ACHTUNG**

- VERIFICARE LE MISURE DI INGOMBRO PER POSSIBILE INTERFERENZA SU ALCUNI MODELLI DI MACCHINE
- Please check the overall sizes for possible interferences on some machine models
- Bitte überprüfen sie das ausmass um mögliche interferenzen auf einigen maschinen modellen zu vermeiden

HW ACHEON  
CUTEX 160  
MODULO MOTORIZZATO PORTACREATORE  
Driven gear hobber  
Angetriebenes Zahnradwaelzfraes-Werkzeug

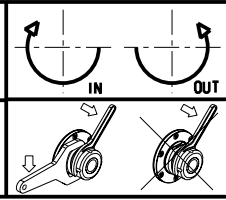

**M.T. srl**  
Via Casino Albini 480  
Tel. 0541/956034-957884  
Fax 0541/956341  
47842 S. GIOVANNI IN M. (RN)  
e-mail: mtma@mtmarchetti.com  
http://www.mtmarchetti.com

PRODUZIONE MODULI ROTANTI

PAGINA HW C 340-1-00

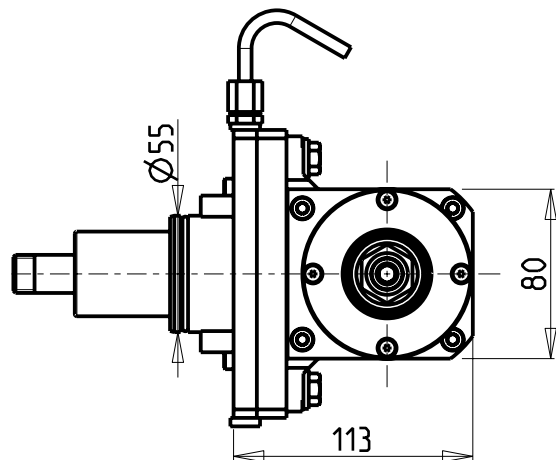
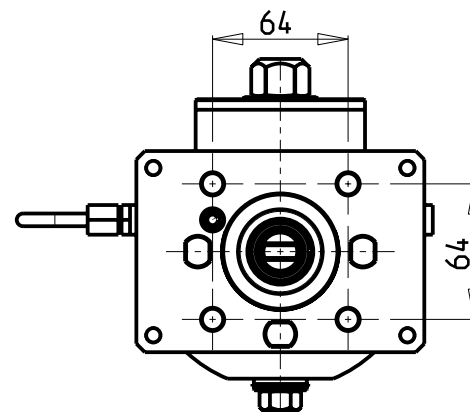
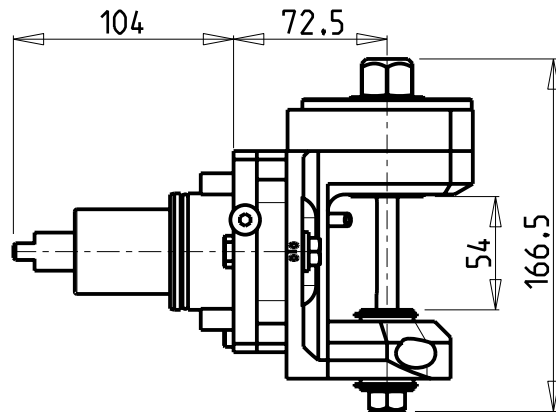
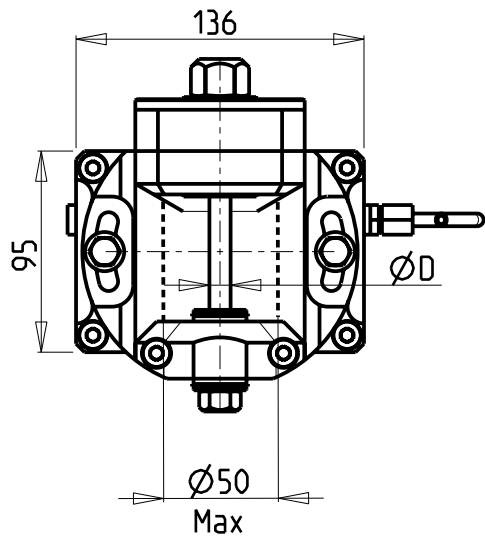

ATTENZIONE - ATTENTION - ACHTUNG

- VERIFICARE LE MISURE DI INGOMBRO PER POSSIBILE INTERFERENZA SU ALCUNI MODELLI DI MACCHINE
- Please check the overall sizes for possible interferences on some machine models
- Bitte überprüfen sie das ausmass um mögliche interferenzen auf einigen maschinen modellen zu vermeiden

INCLINAZIONE  
REGOLABILE ±15°

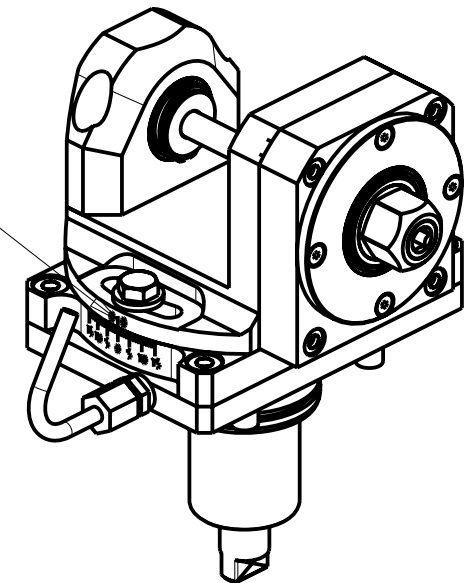

Cod. MT	i	RPM max	Coppia Max Max Torque Max Drehmoment	Lubrificazione est. Ext. coolant Aussenkuehlung	D (mm)	CHIAVI INCLUSE Keys included Schluessel inbegriffen						
						CHUB24	CHUB13	CHESL08	CHESL06	CHESL04		
DW 00051108	1:1	6000	50Nm	X	8	CHUB24	CHUB13	CHESL08	CHESL06	CHESL04		NEW
DW 00051110	1:1	6000	50Nm	X	10	CHUB24	CHUB17	CHUB13	CHESL08	CHESL06	CHESL05	NEW
DW 00051113	1:1	6000	50Nm	X	13	CHUB24	CHUB19	CHUB13	CHESL08	CHESL06		NEW
DW 00051116	1:1	6000	50Nm	X	16	CHUB24	CHUB13	CHESL08	CHESL06			NEW

HW ACHEON  
CUTEX 160

MODULO MOTORIZZATO PORTACREATORE RADIALE  
Radial driven gear hobber  
Radial Angetriebenes Zahnradwaelzfraes-Werkzeug

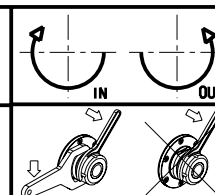

**M.T. srl**

Via Casino Albini 480  
Tel. 0541/956034-957884  
Fax 0541/956341

47842 S. GIOVANNI IN M. (RN)  
e-mail: mtma@mtmarchetti.com  
http://www.mtmarchetti.com

PRODUZIONE MODULI ROTANTI



PAGINA HW C 340-1-30

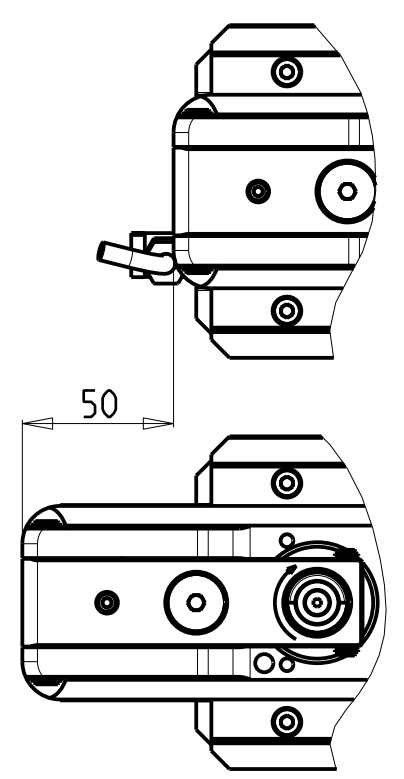
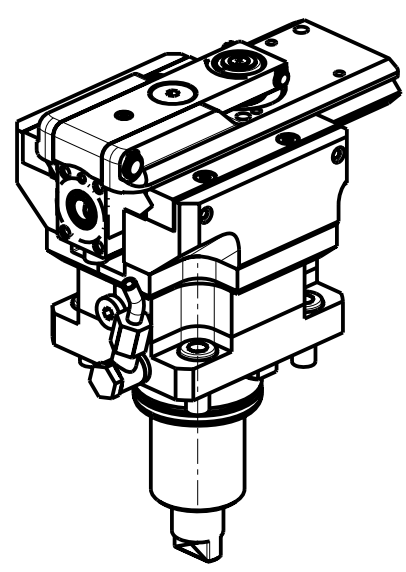
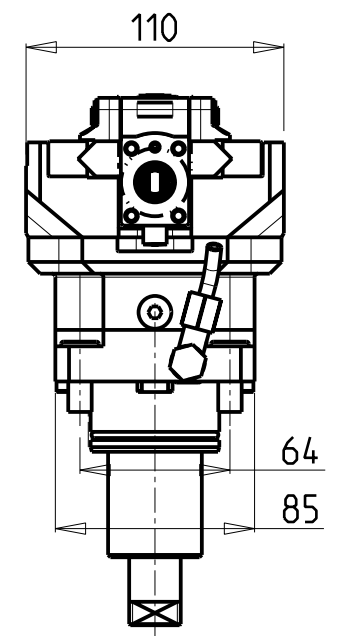
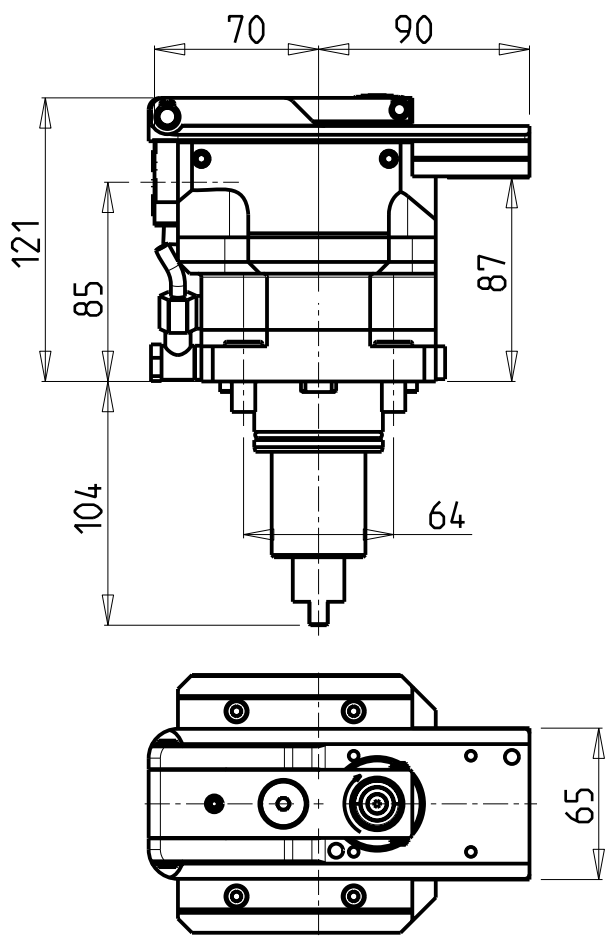

Cod. MT	I	RPM MAX	Reversibile lato mandrino/contromandrino Reversible sub/main spindle side Umkehrbare Spindel-seite/ Gegenspindel-seite	Lubr. esterna Ext. coolant Aussenkuehlung	
DW01030100	4:1	2000	X	X	NEW

PER UTENSILI STOZZATORI VEDI PAG. TBL400-1-00  
 FOR DRIVEN SLOTTING TOOL CUTTING-TOOLS SEE PAGE TBL400-1-00  
 FÜR NUTENSTOSS-WERKZEUG SCHNEIDWERKZEUGE SIEHE SEITE TBL400-1-00

HW ACHEON  
 CUTEX 160  
 MODULO MOTORIZZATO STOZZATORE  
 Slotting driven tool  
 Keilnutenstossmaschine



**M.T. srl**  
 Via Casino Albini 480  
 Tel. 0541/956034-957884  
 Fax 0541/956341  
 47842 S. GIOVANNI IN M. (RN)  
 e-mail: mtma@mtmarchetti.com  
 http://www.mtmarchetti.com

PRODUZIONE MODULI ROTANTI



PAGINA HW C 360-1-00



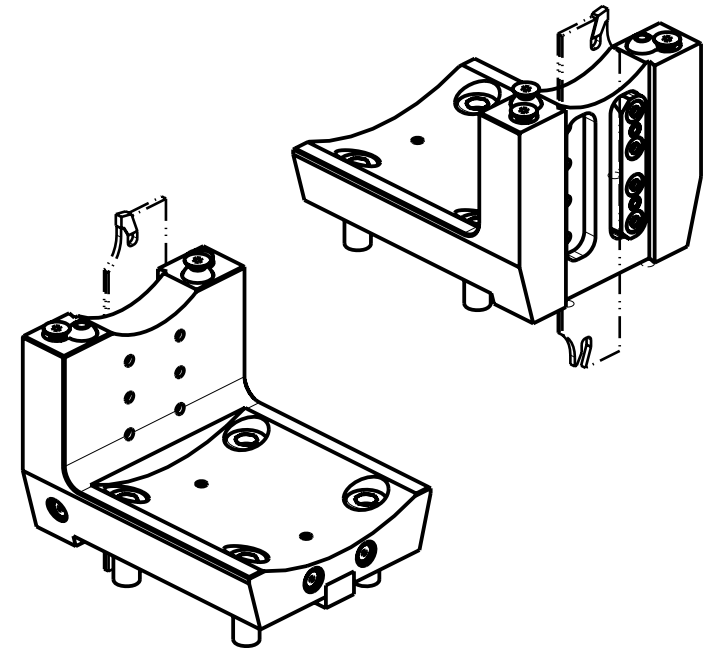
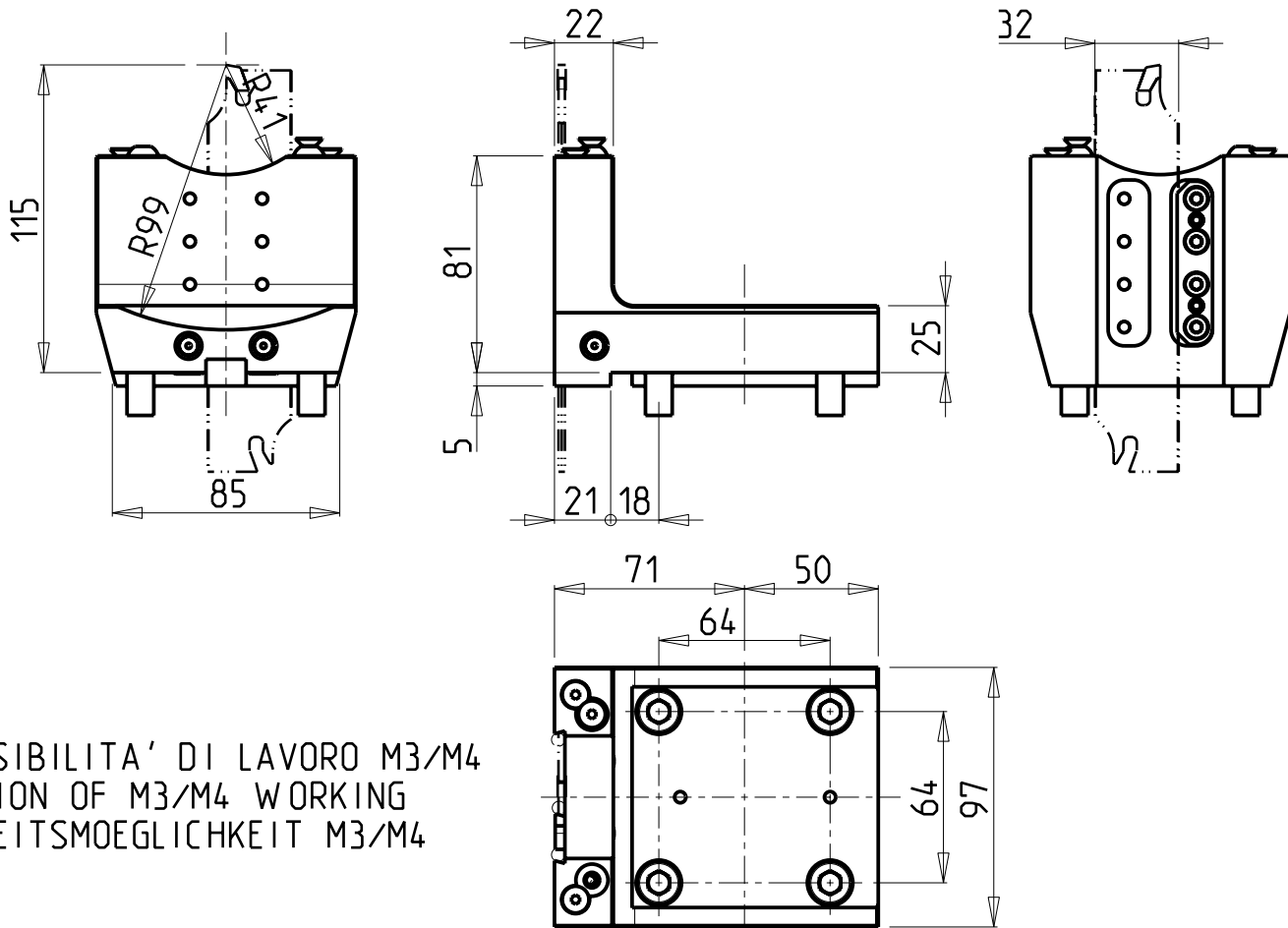

POSSIBILITA' DI LAVORO M3/M4  
 OPTION OF M3/M4 WORKING  
 ARBEITSMOEGlichkeit M3/M4

**DOTAZIONI - SUPPLIED WITH - AUSSTATTUNG**

- N°1 - LAMA - BLADE - KLINGE ISCAR H=32 Sp. 3/4mm (KENNAMETAL OPTIONAL)
- N°10 - INSERTI - INSERTS - EINLAGEN
- N°1 - CHIAVE A T PER MONTAGGIO INSERTI  
 - T-WRENCH FOR INSERT SET UP  
 - T-SCHLUESSEL FUER EINSATZSTUECK-MONTAGE

Cod. MT	N°Utensili N°Tools N°Werkzeuge	Reversibile lato mandrino/contromandrino Reversible sub/main spindle side Umkehrbare Spindel-seite/ Gegenspindel-seite	Lubr.esterna Ext. coolant Aussenkuehlung	
DW 00730132	1	X	X	NEW

HW ACHEON  
 CUTEX 160

PORTAUTENSILE RADIALE PER LAMA  
 Radial blade holder  
 Radial Abstechhalter

**M.T. srl**

Via Casino Albini 480  
 Tel. 0541/956034-957884  
 Fax 0541/956341  
 47842 S. GIOVANNI IN M. (RN)  
 e-mail: mtma@mtmarchetti.com  
 http://www.mtmarchetti.com

PRODUZIONE MODULI ROTANTI



PAGINA HW C510-1-00

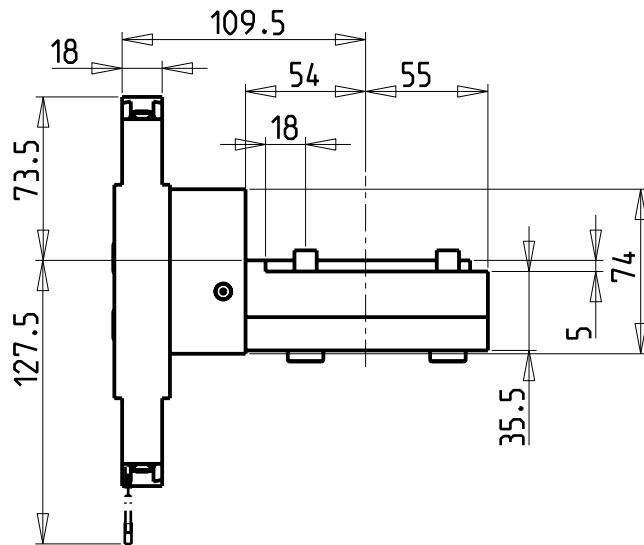
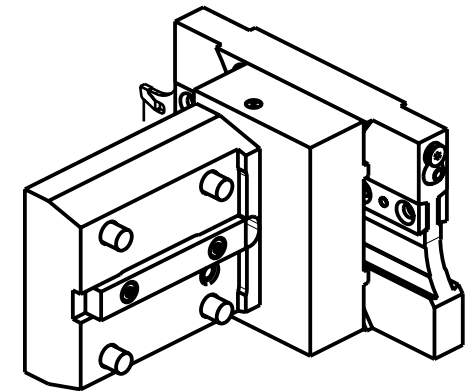
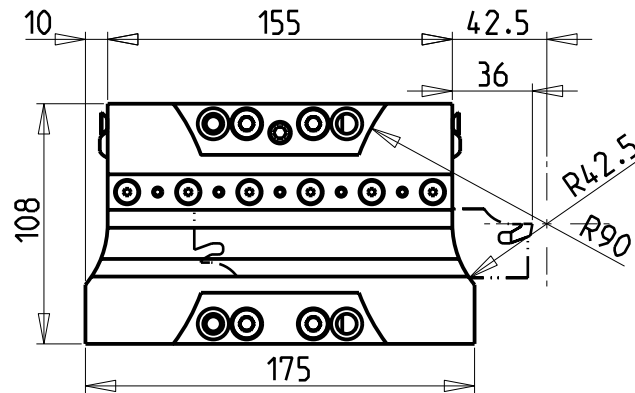
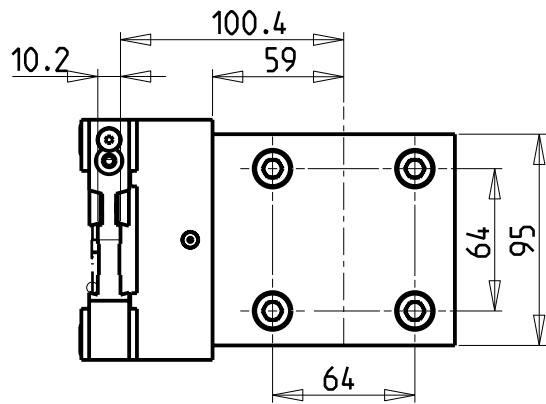

POSSIBILITA' DI LAVORO M3/M4  
 OPTION OF M3/M4 WORKING  
 ARBEITSMÖGLICHKEIT M3/M4

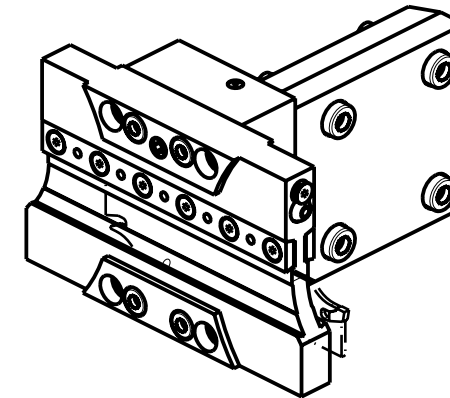

ATTENZIONE - ATTENTION - ACHTUNG

- FINO AD ESAURIMENTO SCORTE
- clearance sale
- solange vorrat

**DOTAZIONI - SUPPLIED WITH - AUSSTATTUNG**

- N°1 - LAMA - BLADE - KLINGE ISCAR H=32 Sp. 3/4mm (KENNAMETAL OPTIONAL)
- N°10 - INSERTI - INSERTS - EINLAGEN
- N°1 - CHIAVE A T PER MONTAGGIO INSERTI  
 - T-WRENCH FOR INSERT SET UP  
 - T-SCHLUESSEL FUER EINSATZSTUECK-MONTAGE

Cod. MT	N°Utensili N°Tools N°Werkzeuge
0790132	1

NEW

HW ACHEON  
 CUTEX 160  
 PORTAUTENSILE PER LAMA DOPPIO  
 Radial double blade holder  
 Radial Doppel-Abstechhalter

**M.T. srl**  
 Via Casino Albini 480  
 Tel. 0541/956034-957884  
 Fax 0541/956341  
 47842 S. GIOVANNI IN M. (RN)  
 e-mail: mtma@mtmarchetti.com  
 http://www.mtmarchetti.com

PRODUZIONE MODULI ROTANTI



PAGINA HW C520-1-00

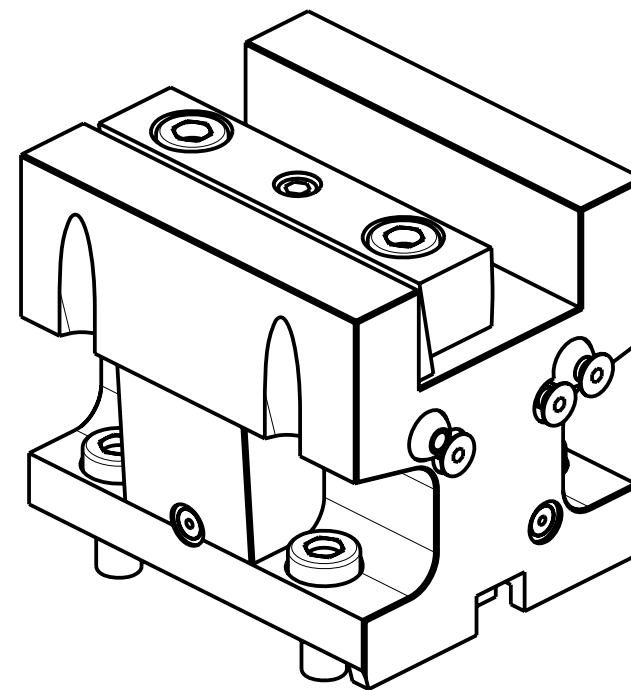
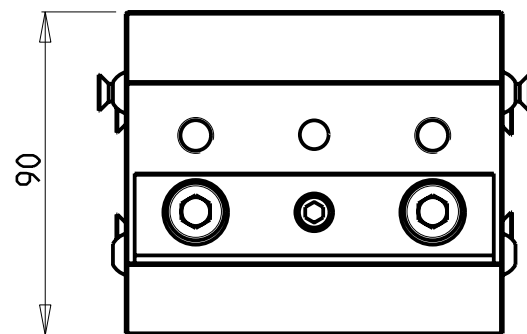
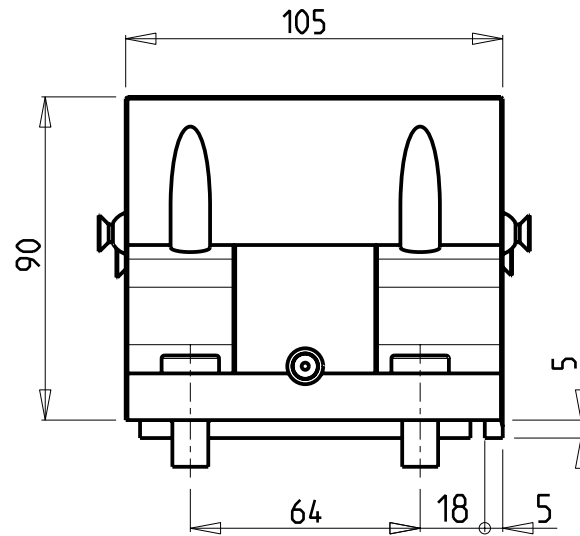
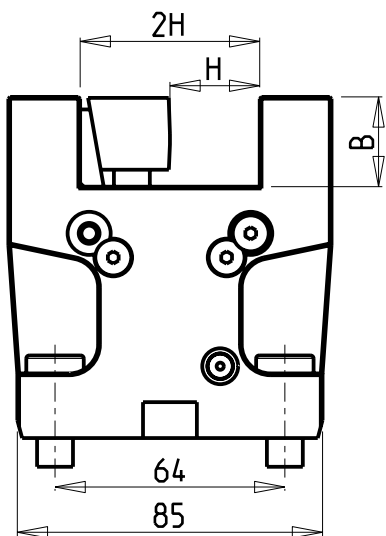

Cod. MT	N°Utensili N°Tools N°Werkzeuge	Reversibile lato mandrino/contromandrino Reversible sub/main spindle side Umkehrbare Spindel-seite/ Gegenspindel-seite	Misure Dimensions Masse	B	H	
DW00422500	1	X	mm	25	25	NEW
DW00422540	1	X	Inch	1"	1"	NEW

HW ACHEON  
CUTEX 160

PORTAUTENSILE ASSIALE SINGOLO  
Axial single static tool  
Axial Single-Werkzeughalter

**M.T. srl**

Via Casino Albini 480  
Tel. 0541/956034-957884  
Fax 0541/956341  
47842 S. GIOVANNI IN M. (RN)  
e-mail: mtma@mtmarchetti.com  
http://www.mtmarchetti.com

PRODUZIONE MODULI ROTANTI



PAGINA HW C552-1-00

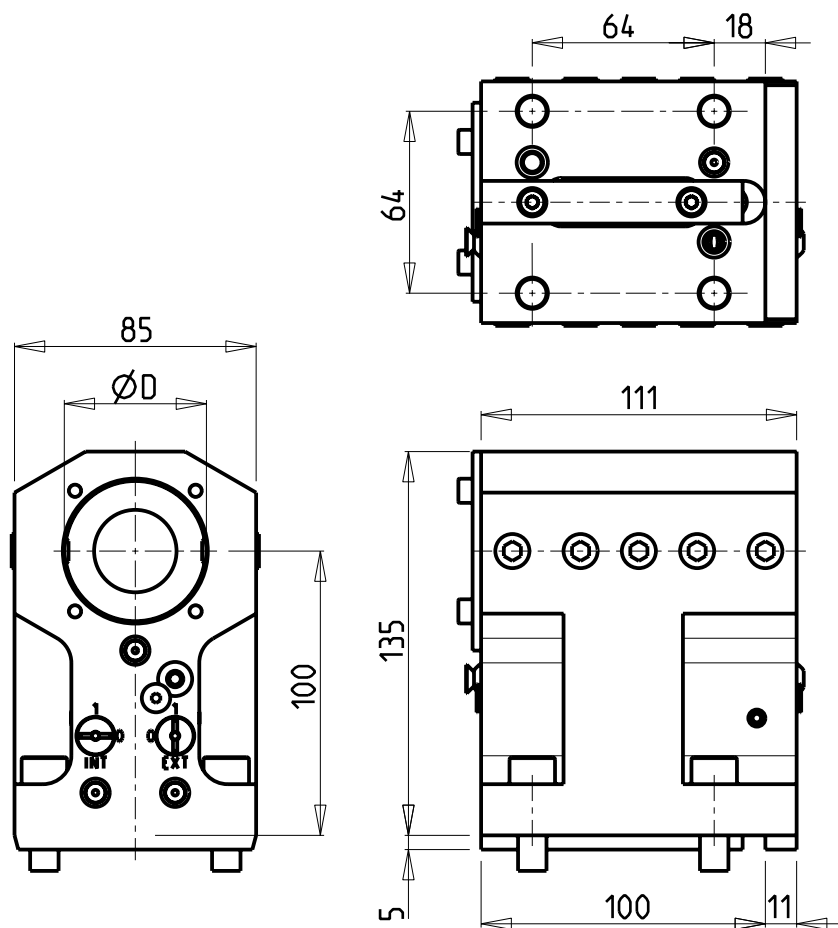

PER BOCCOLE DI RIDUZIONE VEDI PAG. TBL150-1-00  
 FOR REDUCING BUSHINGS SEE PAGE TBL150-1-00  
 FÜR REDUZIERBUCHSE SIEHE SEITE TBL150-1-00

KIT ADDUZIONE INTERNA (OPZIONALE)  
 KIT FOR INTERNAL COOLANT (OPTIONAL)  
 KIT FÜR INTERNE KUEHLMITTELZUFUHR (OPTIONAL)  
 Ø50-Ø2" cod. KIT1000002

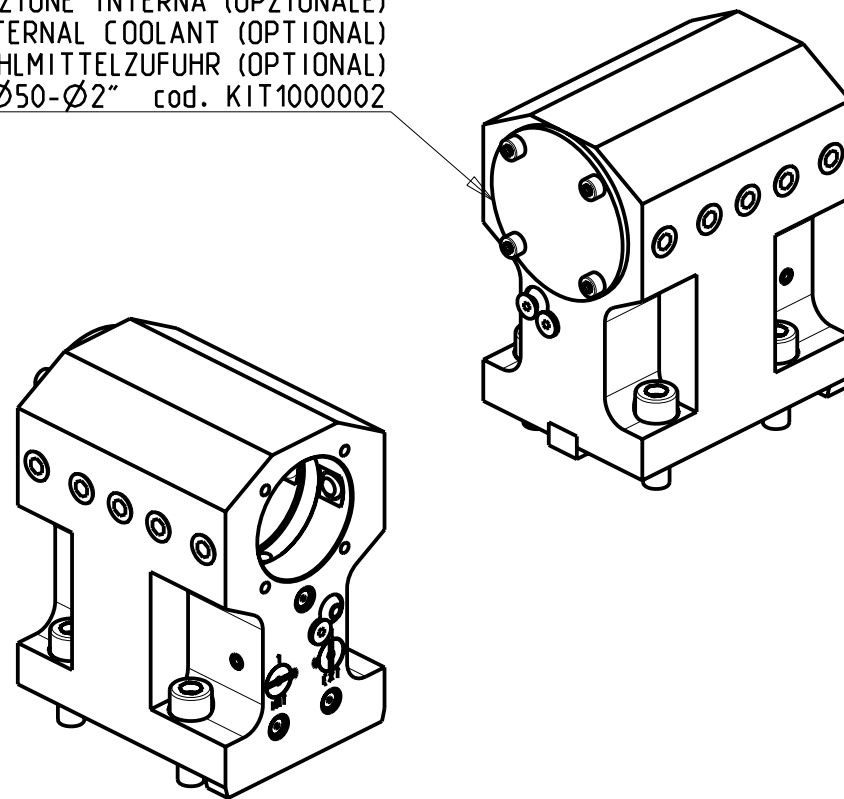

Cod. MT	N°Utensili N°Tools N°Werkzeuge	Reversibile lato mandrino/contromandrino Reversible sub/main spindle side Umkehrbare Spindel-seite/ Gegenspindel-seite	Lubrificazione int. opzionale Coolant through optional Innenkuehlung Optional	Lubrificazione est. Ext. coolant Aussenkuehlung	Misure Dimensions Masse	D
DW 01115000	1	X	X	X	mm	50
DW 01115080	1	X	X	X	Inch	2"

NEW

NEW

HW ACHEON  
 CUTEX 160

PORTAUTENSILE ASSIALE PER BARENO Ø50mm / Ø2" H=100mm  
 Axial single boring bar holder Ø50mm / Ø2" H=100mm  
 Axial Bohrhälter Ø50mm / Ø2" H=100mm

**M.T. srl**

Via Casino Albini 480  
 Tel. 0541/956034-957884  
 Fax 0541/956341  
 47842 S. GIOVANNI IN M. (RN)  
 e-mail: mtma@mtmarchetti.com  
 http://www.mtmarchetti.com

PRODUZIONE MODULI ROTANTI



PAGINA HW C 620-1-10

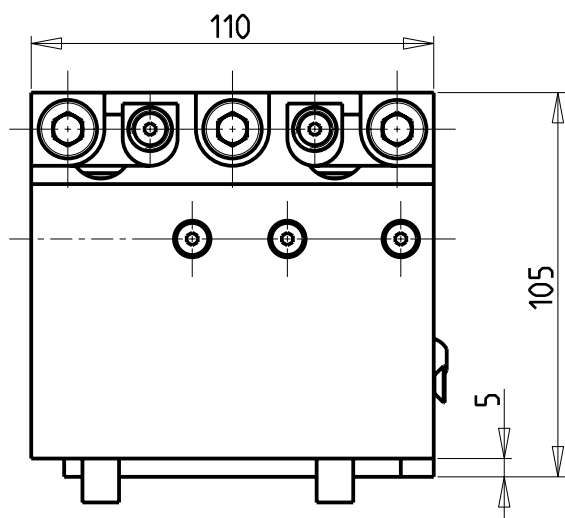
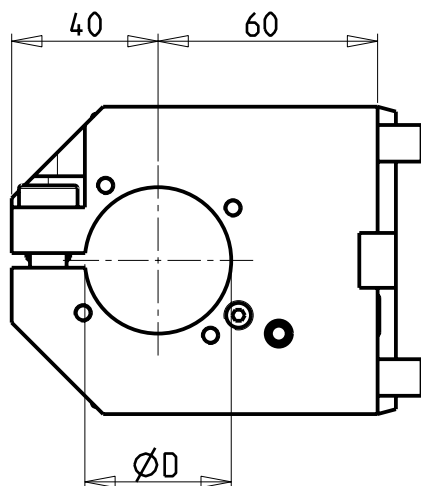
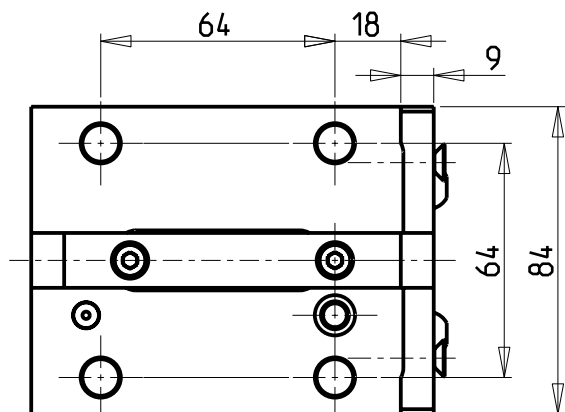

KIT ADDUZIONE INTERNA (OPZIONALE)  
 KIT FOR INTERNAL COOLANT (OPTIONAL)  
 KIT FUER INTERNE KUEHLMITTELZUFUHR (OPTIONAL)  
 Ø40 cod. KIT1003003  
 Ø1 1/2" cod. KIT1003004

SOLO GUARNIZIONE (OPZIONALE)  
 ONLY SEAL (OPTIONAL)  
 NUR DICHTUNG (OPTIONAL)  
 cod. 0520013

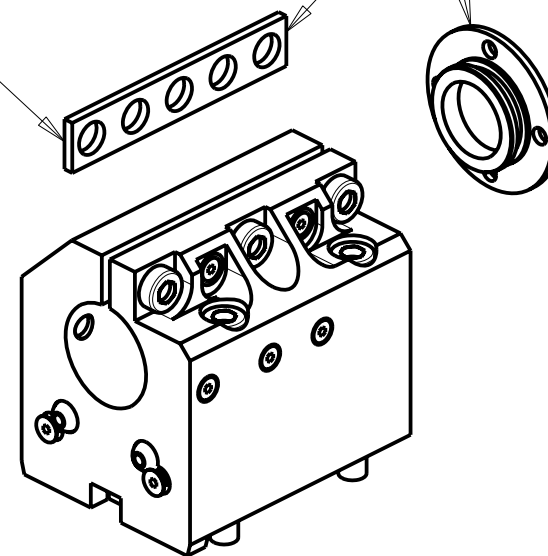

PER BOCCOLE DI RIDUZIONE VEDI PAG. TBL150-1-00  
 FOR REDUCING BUSHINGS SEE PAGE TBL150-1-00  
 FÜR REDUZIERBUCHSE SIEHE SEITE TBL150-1-00

Cod. MT	N°Utensili N°Tools N°Werkzeuge	Reversibile lato mandrino/contromandrino Reversible sub/main spindle side Umkehrbare Spindel-seite/ Gegenspindel-seite	Lubrificazione int. opzionale Coolant through optional Innenkuhlung Optional	Lubrificazione est. Ext. coolant Aussenkuhlung	Misure Dimensions Masse	D
0814000	1	X	X	X	mm	40
0813810	1	X	X	X	Inch	1 1/2"

NEW

NEW

HW ACHEON  
 CUTEX 160

PORTAUTENSILE ASSIALE PER BARENO Ø40mm / Ø1 1/2" H=60mm  
 Axial single boring bar holder Ø40mm / Ø1 1/2" H=60mm  
 Axial Bohrhälter Ø40mm / Ø1 1/2" H=60mm

**M.T. srl**

Via Casino Albini 480  
 Tel. 0541/956034-957884  
 Fax 0541/956341  
 47842 S. GIOVANNI IN M. (RN)  
 e-mail: mtma@mtmarchetti.com  
 http://www.mtmarchetti.com

PRODUZIONE MODULI ROTANTI



PAGINA HW C 630-1-20

PER BOCCOLE DI RIDUZIONE VEDI PAG. TBL150-1-00  
 FOR REDUCING BUSHINGS SEE PAGE TBL150-1-00  
 FÜR REDUZIERBUCHSE SIEHE SEITE TBL150-1-00

KIT ADDUZIONE INTERNA (OPZIONALE)  
 KIT FOR INTERNAL COOLANT (OPTIONAL)  
 KIT FUER INTERNE KUEHLMITTELZUFUHR (OPTIONAL)  
 Ø40 cod. KIT1000003  
 Ø1 1/2" cod. KIT1000004

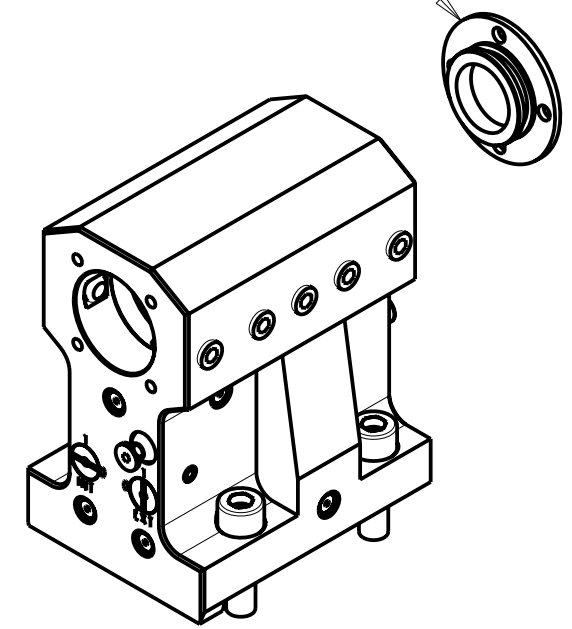
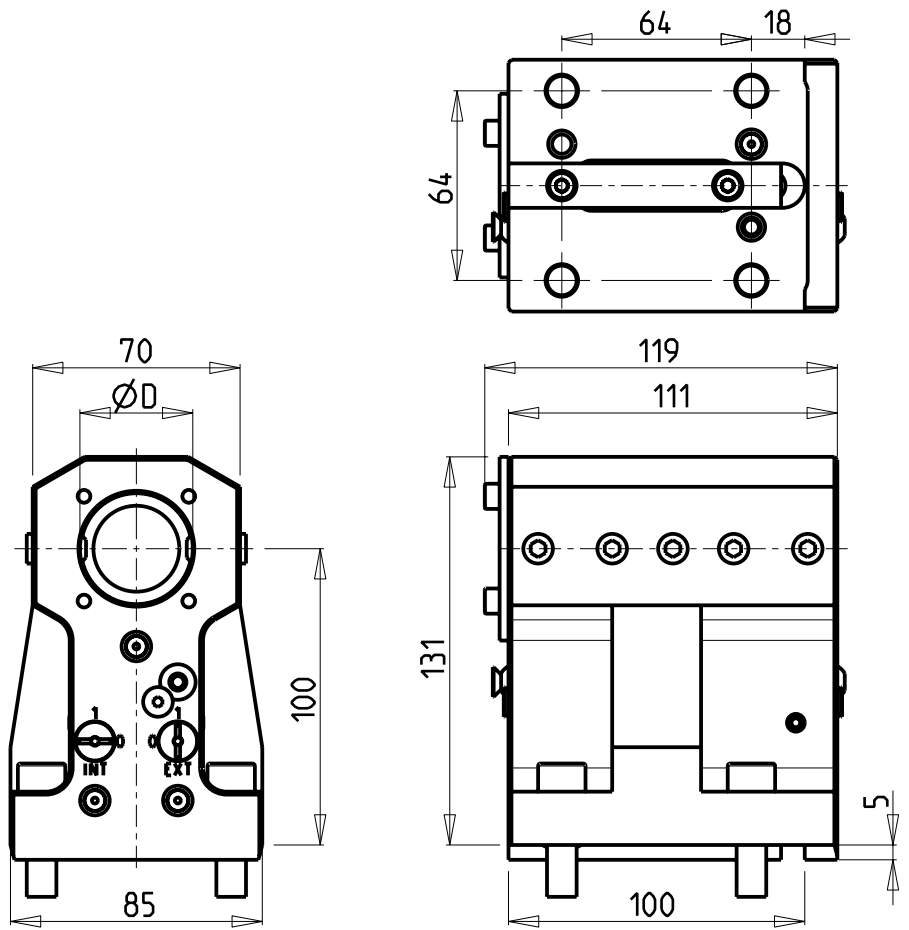

Cod. MT	N°Utensili N° Tools N° Werkzeuge	Reversibile lato mandrino/contromandrino Reversible sub/main spindle side Umkehrbare Spindel-seite/ Gegenspindel-seite	Lubrificazione int. opzionale Coolant through optional Innenkuehlung Optional	Lubrificazione est. Ext. coolant Aussenkuehlung	Misure Dimensions Masse	D
DW 00394000	1	X	X	X	mm	40
DW 00393810	1	X	X	X	Inch	1 1/2"

NEW  
NEW

HW ACHEON  
 CUTEX 160  
 PORTAUTENSILE ASSIALE PER BARENO Ø40mm / Ø1 1/2" H=100mm  
 Axial single boring bar holder Ø40mm / Ø1 1/2" H=100mm  
 Axial Bohrhälter Ø40mm / Ø1 1/2" H=100mm

**M.T. srl**  
 Via Casino Albini 480  
 Tel. 0541/956034-957884  
 Fax 0541/956341  
 47842 S. GIOVANNI IN M. (RN)  
 e-mail: mtma@mtmarchetti.com  
 http://www.mtmarchetti.com

PRODUZIONE MODULI ROTANTI

PAGINA HWC640-1-10

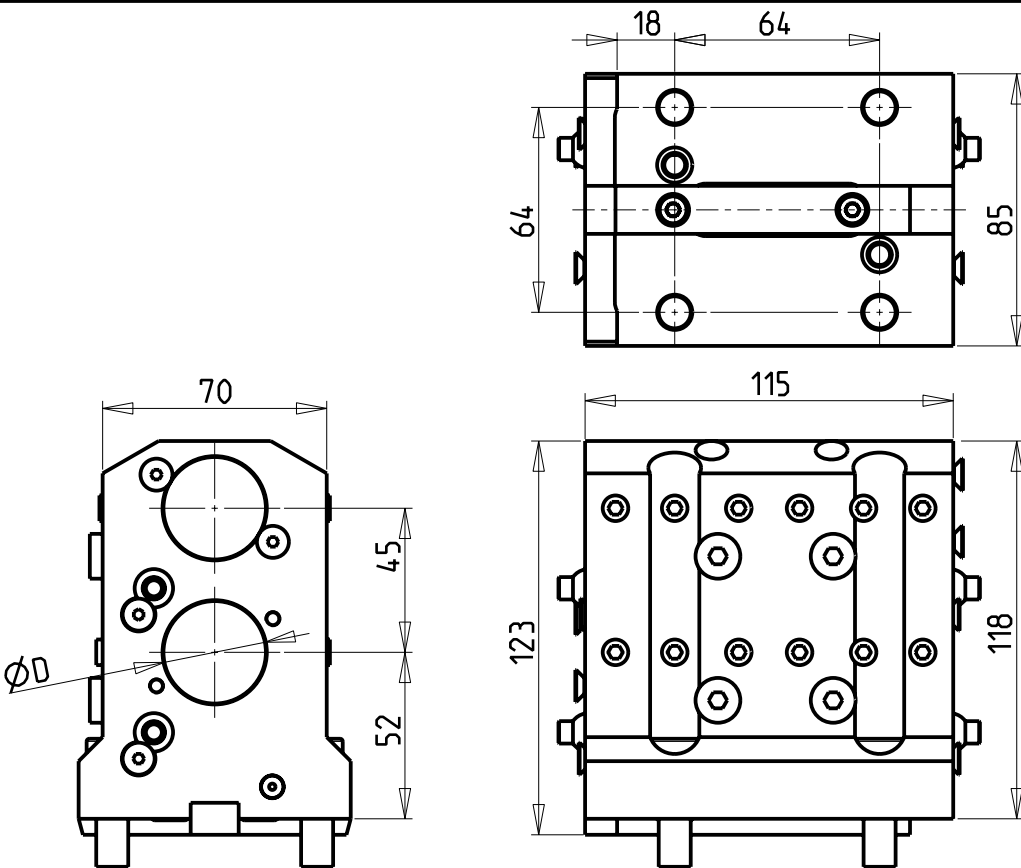

KIT ADDUZIONE INTERNA (OPZIONALE)  
 KIT FOR INTERNAL COOLANT (OPTIONAL)  
 KIT FUER INTERNE KUEHLMITTELZUFUHR (OPTIONAL)  
 Ø25-1" cod. KIT1000006  
 Ø32-1 1/4" cod. KIT1000001

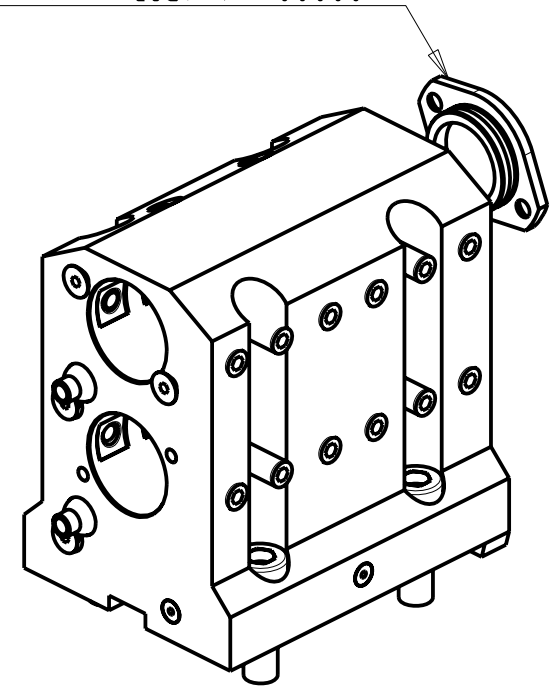

Cod. MT	N°Utensili N°Tools N°Werkzeuge	Reversibile lato mandrino/contromandrino Reversible sub/main spindle side Umkehrbare Spindel-seite/ Gegenspindel-seite	Lubrificazione int. opzionale Coolant through optional Innenkuhlung Optional	Lubrificazione est. Ext. coolant Aussehenkuhlung	Misure Dimensions Masse	D
DW 00092500	2	X	X	X	mm	25
DW 00092540	2	X	X	X	Inch	1"
DW 00093175	2	X	X	X	Inch	1 1/4"
DW 00093200	2	X	X	X	mm	32

NEW  
 NEW  
 NEW  
 NEW

PER BOCCOLE DI RIDUZIONE VEDI PAG. TBL150-1-00  
 FOR REDUCING BUSHINGS SEE PAGE TBL150-1-00  
 FÜR REDUZIERBUCHSE SIEHE SEITE TBL150-1-00

HW ACHEON  
 CUTEX 160

PORTAUTENSILE ASSIALE PER BARENO 2 POSIZIONI Ø25mm / Ø1" / Ø1 1/4" / Ø32mm  
 Axial double boring bar holder Ø25mm / Ø1" / Ø1 1/4" / Ø32mm  
 Axial Bohrhälter 2 Positionen Ø25mm / Ø1" / Ø1 1/4" / Ø32mm

**M.T. srl**

Via Casino Albini 480  
 Tel. 0541/956034-957884  
 Fax 0541/956341  
 47842 S. GIOVANNI IN M. (RN)  
 e-mail: mtma@mtmarchetti.com  
 http://www.mtmarchetti.com

PRODUZIONE MODULI ROTANTI



PAGINA HWC862-1-00

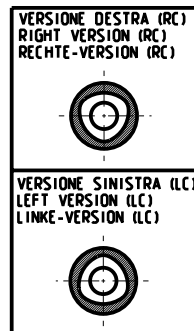
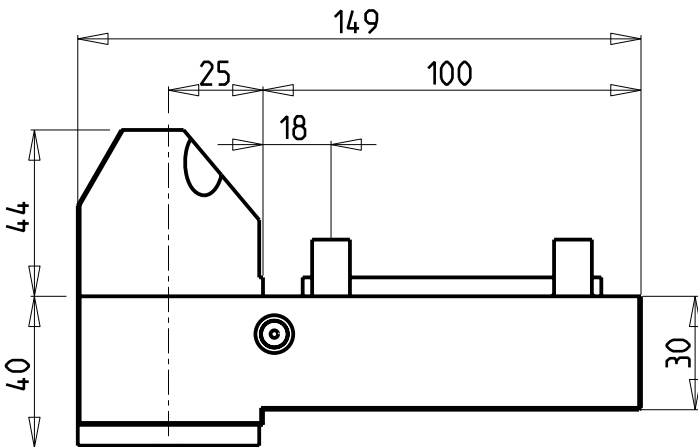
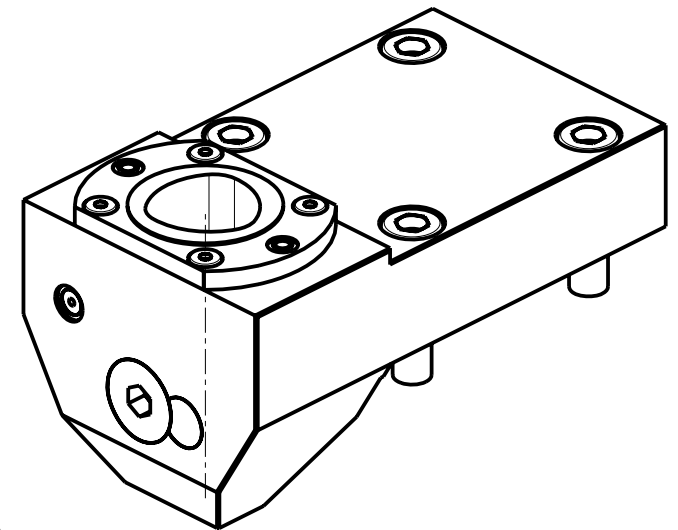
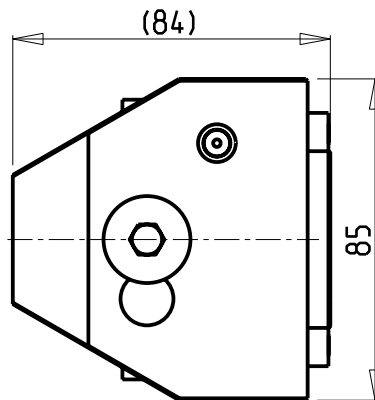
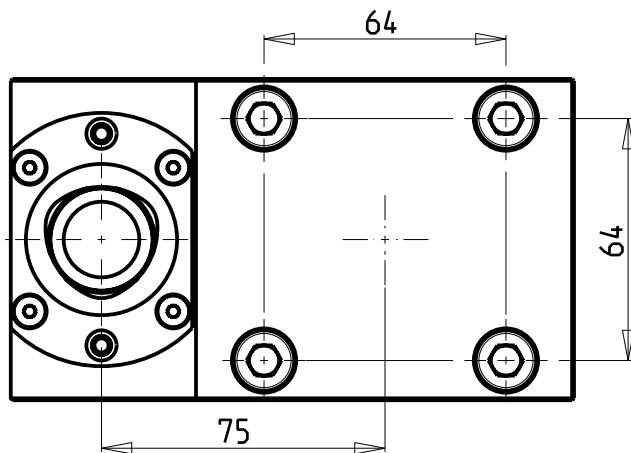

PER ORDINARE LA VERSIONE SX  
AGGIUNGERE "LC" AL CODICE IN TABELLA.  
ES: MNL0464010 DIVENTA MNL0464010LC

TO ORDER LEFT VERSION  
ADD A "LC" IN THE CODE-CHARTS.  
EXAMPLE: MNL0464010 BECOMES MNL0464010LC

UM DIE LINKE-VERSION ZU BESTELLEN, BEI DER  
ARTIKELBEZEICHNUNG "LC" HINZUFUEGEN.  
BEISPIEL: MNL0464010 WIRD DANN MNL0464010LC

Cod. MT	N°Utensili N°Tools N°Werkzeuge	Lubrificazione int. Coolant through Innenkuehlung	Reversibile lato mandrino/contromandrino Reversible sub/main spindle side Umkehrbare Spindelseite/ Gegenspindelseite	TAGLIA Size Masse	
DW00444010	1	X	X	C4	NEW

HWACHEON  
CUTEX 160

PORTAUTENSILE RADIALE SINGOLO ARRETRATO COROMANT CAPTO®  
Single rear-set radial static tool COROMANT CAPTO®  
Radial Single-Werkzeughalter zurueckversetzt COROMANT CAPTO®

**M.T. srl**

Via Casino Albini 480  
Tel. 0541/956034-957884  
Fax 0541/956341  
47842 S. GIOVANNI IN M. (RN)  
e-mail: mtma@mtmarchetti.com  
http://www.mtmarchetti.com

PRODUZIONE MODULI ROTANTI



PAGINA HWC430-A-40



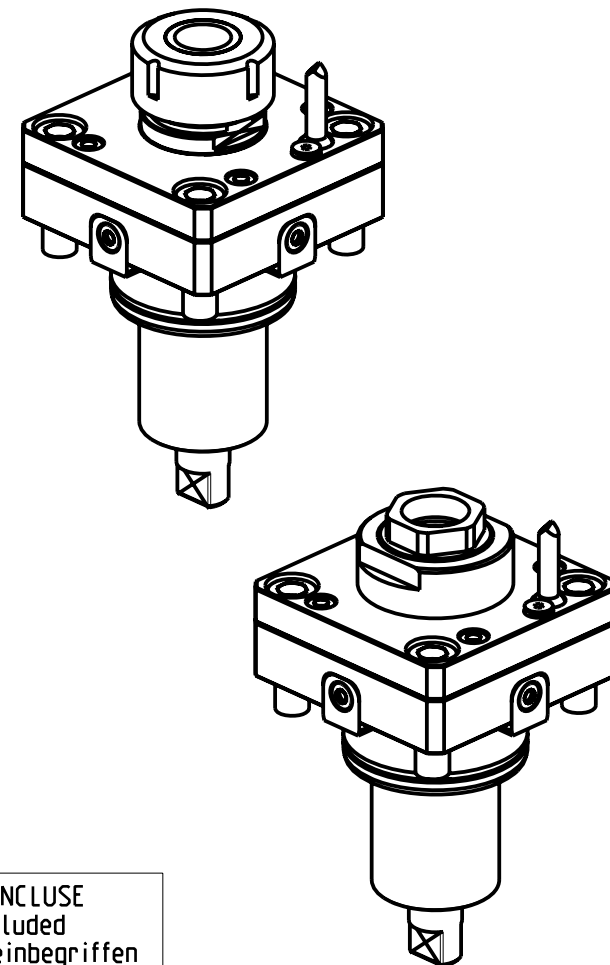
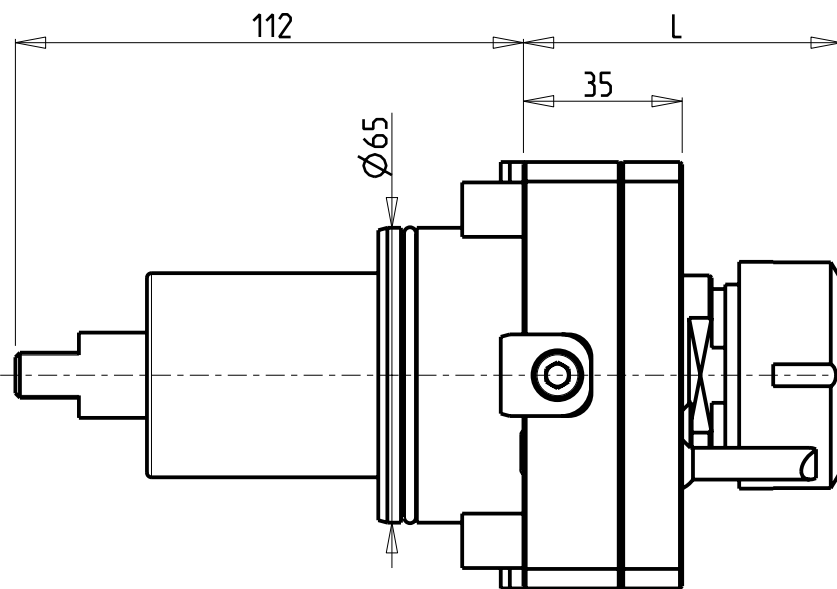
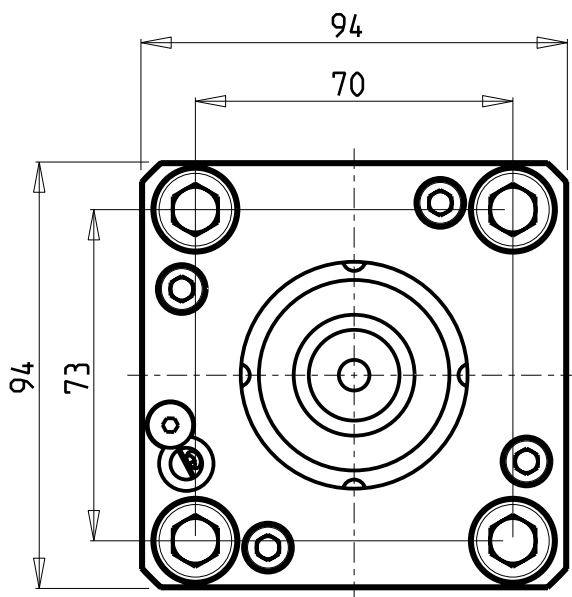

Cod. MT	Cod. EPPINGER	Mandrino Spindel Spindel	I	RPM	Coppia Max Max Torque Max Drehmoment	Lubrificazione int. Coolant through Innenkuehlung	Lubrificazione est. Ext. coolant Ausseukuehlung	L	CHIAVI NON INCLUSE Keys not included Schluessel nicht einbegriffen		
									CHSTER32	CHUB36 o 0280018	
0281532	7.070.636	ER32	1:1	6000	70Nm		X	70.06	CHSTER32	CHUB36 o 0280018	NEW
0281032	-	ER32	1:1	6000	70Nm	P=30bar		70.06	CHSTER32	CHUB36 o 0280018	NEW
0280132	-	ER A 32	1:1	6000	70Nm		X	64.26	CHUB32	CHUB36 o 0280018	NEW
0280232	-	ER A 32	1:1	6000	70Nm	P=30bar		70.53	CHUB32	CHUB36 o 0280018	NEW

## HW ACHEON

HI-TECH 200 - HI-TECH 300/400 - HI-TECH 450 - VT450 - T2 - CUTEX 240

MODULO MOTORIZZATO RADIALE

Radial driven tool

Radial angetriebenes Werkzeug

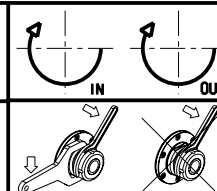

## M.T. srl

Via Casino Albini 480  
Tel. 0541/956034-957884  
Fax 0541/956341

47842 S. GIOVANNI IN M. (RN)  
e-mail: mtma@mtmarchetti.com  
http://www.mtmarchetti.com

PRODUZIONE MODULI ROTANTI



PAGINA HWC010-2-00

## CUSCINETTI MAGGIORATI PER LAVORAZIONI PESANTI

Reinforced bearings for  
heavy machining

Vergroesserte Lager fuer  
schwerere Bearbeitungen

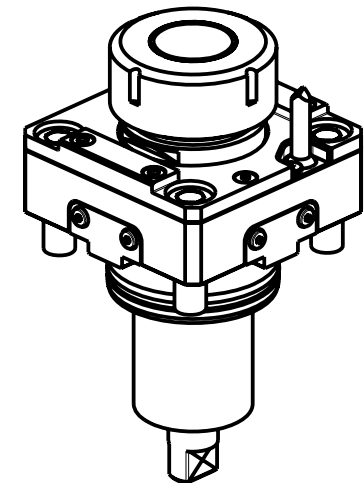
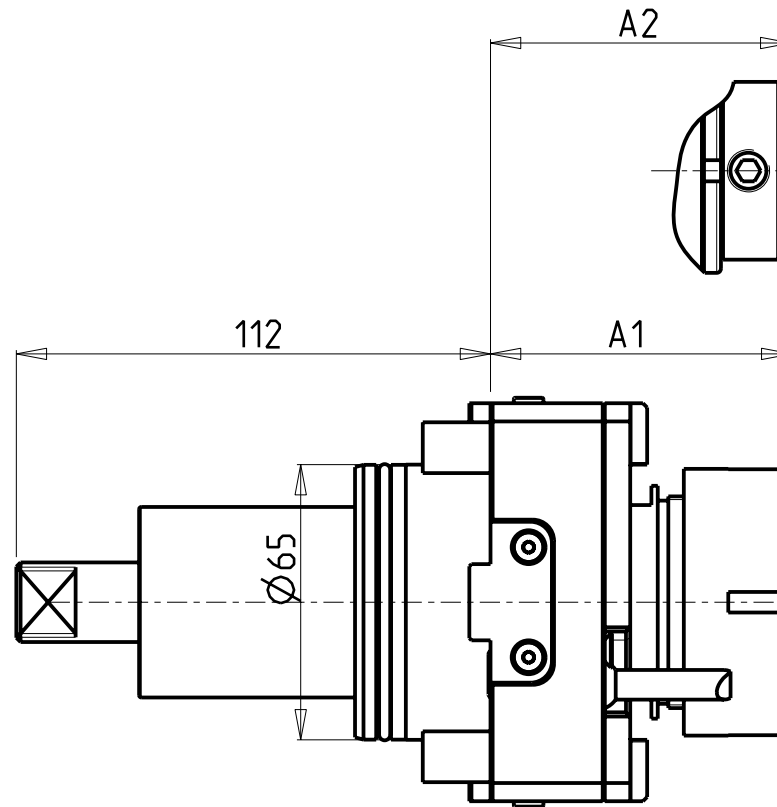
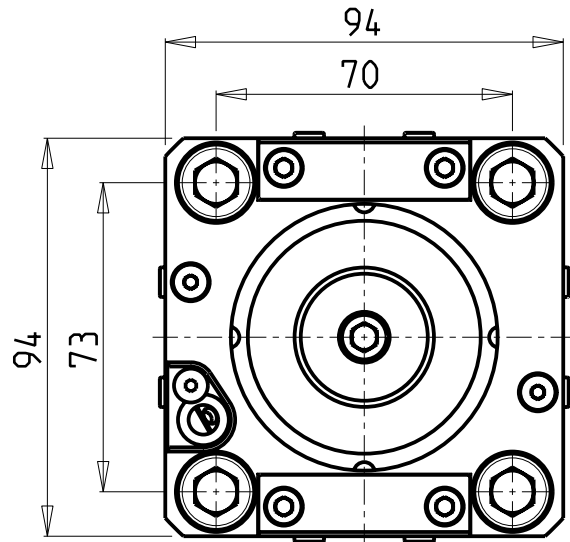

Cod. MT	Mandrino Spindle Spindel	I	RPM	Coppia Max Max Torque Max Drehmoment	Lubrificazione int. Coolant through Innenkuehlung	Lubrificazione est. Ext. coolant Aussenkuehlung	A1	A2	CHIAVI NON INCLUSE Keys not included Schluessel nicht einbegriffen		
DW00640140	ER40	1:1	6000	70Nm		X	71.16		CHSTER40	OKU0650004	NEW
DW00640240	ER40	1:1	6000	70Nm	P=30bar	X	82.16		CHSTER40	OKU0650004	NEW
DW00640625	WELDON25	1:1	6000	70Nm	P=30bar	X		72.5	-	-	NEW

• Chiave inclusa

• Key included

• Schluessel inbegriffen

HW ACHEON

HI-TECH 200 - HI-TECH 300/400 - HI-TECH 450 - VT450 - T2 - CUTEX 240

MODULO MOTORIZZATO RADIALE MAGGIORATO

Radial reinforced driven tool

Radial angetriebenes Werkzeug vergroessert

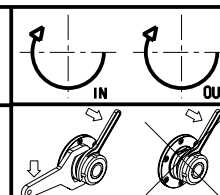

**M.T. srl**

Via Casino Albini 480  
Tel. 0541/956034-957884

Fax 0541/956341

47842 S. GIOVANNI IN M. (RN)

e-mail: mtma@mtmarchetti.com

http://www.mtmarchetti.com

PRODUZIONE MODULI ROTANTI



PAGINA HWC020-2-00

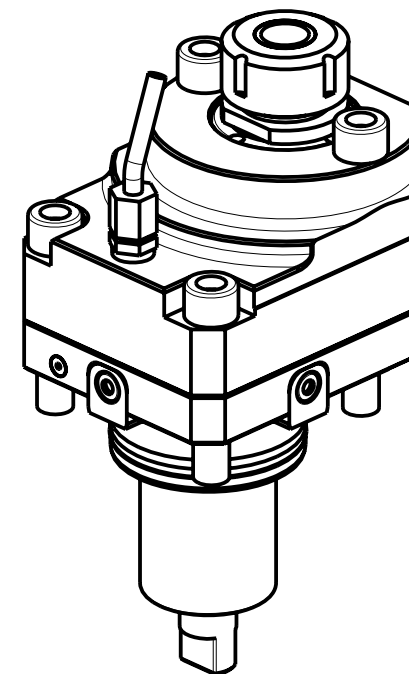
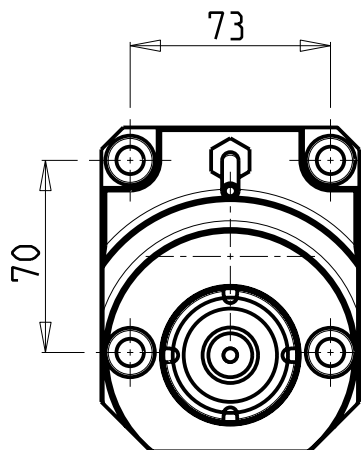
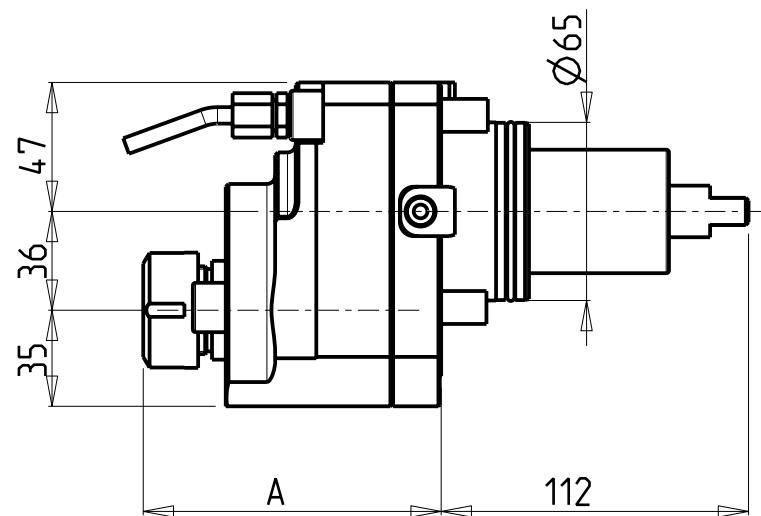
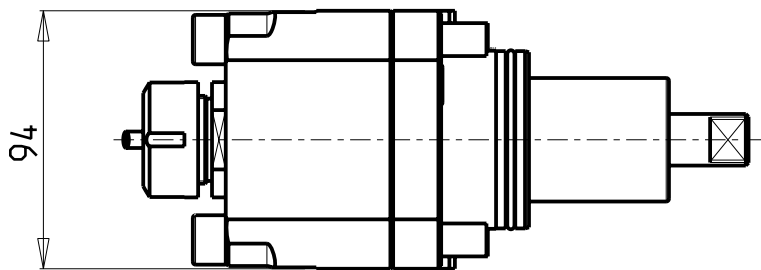

Cod. MT	Mandrino Spindle Spindel	I	RPM	Coppia Max Max Torque Max Drehmoment	Reversibile lato mandrino/contromandrino Reversible sub/main spindle side Umkehrbare Spindelseite/ Gegenspindelseite	Lubrificazione est. Ext. coolant Aussenkuehlung	A	CHIAVI NON INCLUSE Keys not included Schlüssel nicht einbegriffen
DW00140125	ER25	1:2	12000	30Nm	X	X	108.56	CHSTER25

NEW

**HW ACHEON**

HI-TECH 200 - HI-TECH 300/400 - HI-TECH 450 - VT450 - T2 - CUTEX 240

MODULO MOTORIZZATO RADIALE MOLTIPLICATO I=1:2 DISASSATO IN Z 36mm

Radial geared-up I=1:2 driven tool re-directed in Z by 36mm

Radial angetriebenes Werkzeug uebersetzt I=1:2 achsversetzt in Z um 36mm

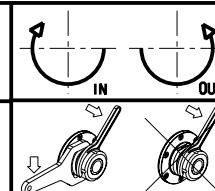

**M.T. srl**

Via Casino Albini 480  
Tel. 0541/956034-957884  
Fax 0541/956341

47842 S. GIOVANNI IN M. (RN)  
e-mail: mtma@mtmarchetti.com  
http://www.mtmarchetti.com

PRODUZIONE MODULI ROTANTI



PAGINA HWC030-2-30

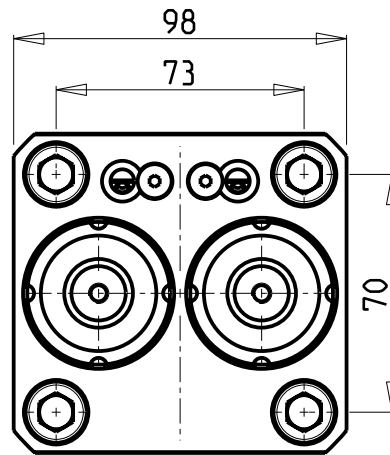
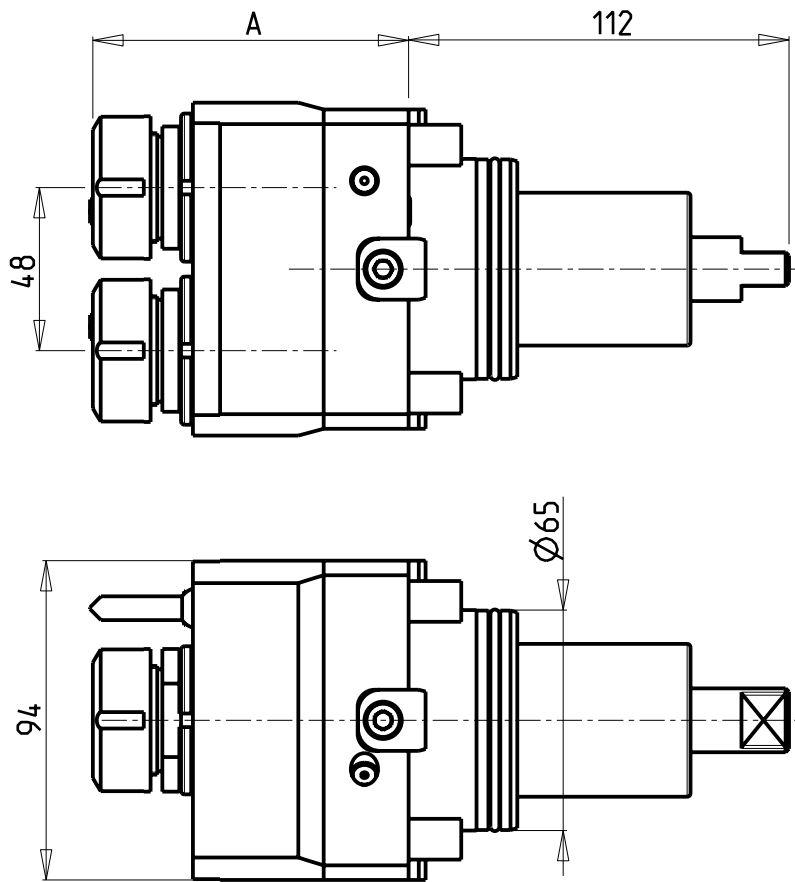

### ATTENZIONE - ATTENTION - ACHTUNG

- Per lo smontaggio degli utensili utilizzare sempre la chiave di contrasto come indicato nel manuale d'uso.
- For disassembly of the tools use always the contrast key as mentioned in the user instructions.
- Fuer das Abmontieren der Werkzeuge immer den Gegenschlüssel benutzen wie in der Bedienungsanleitung erwäohnt.

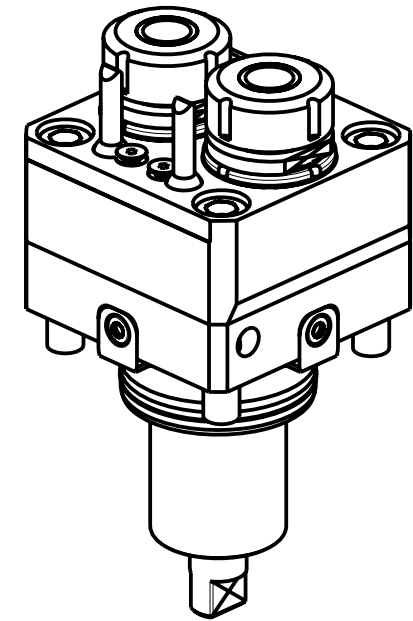

Cod. MT	Mandrino Spindle Spindel	I	RPM	Coppia Max Max Torque Max Drehmoment	Lubrificazione est. Ext. coolant Ausseukuehlung	A	CHIAVI NON INCLUDE Keys not included Schluessel nicht einbegriffen		
							CHMNER16	CHUB17	
DW00540216	ER16	1:1	6000	30Nm	X	84.5	CHMNER16	CHUB17	NEW
DW00540225	ER25	1:1	6000	30Nm	X	85	CHSTER25	MNL0210007	NEW

HW ACHEON  
HI-TECH 450 - T2

MODULO MOTORIZZATO RADIALE 2 USCITE IN Y  
Radial single side twin head driven tool in Y  
Radial angetriebenes Werkzeug 2 Ausgaenge in Y

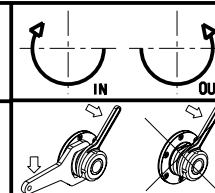

**M.T. srl**  
Via Casino Albini 480  
Tel. 0541/956034-957884  
Fax 0541/956341  
47842 S. GIOVANNI IN M. (RN)  
e-mail: mtma@mtmarchetti.com  
http://www.mtmarchetti.com

PRODUZIONE MODULI ROTANTI



PAGINA HWC080-2-00

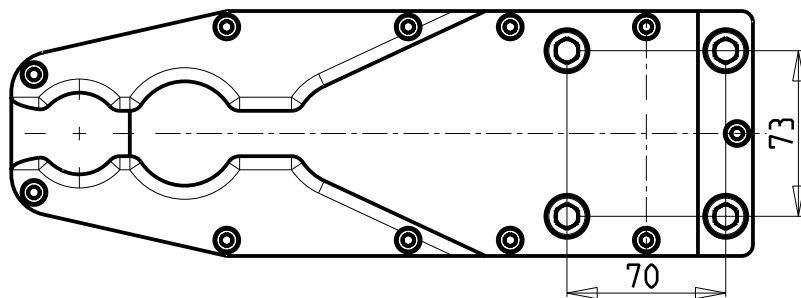
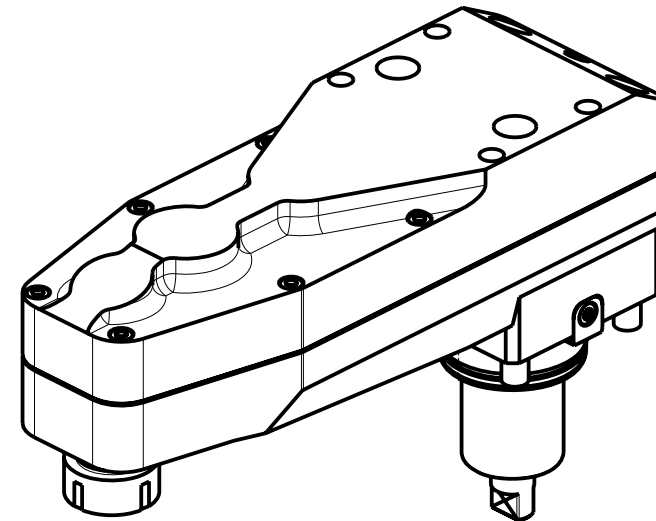
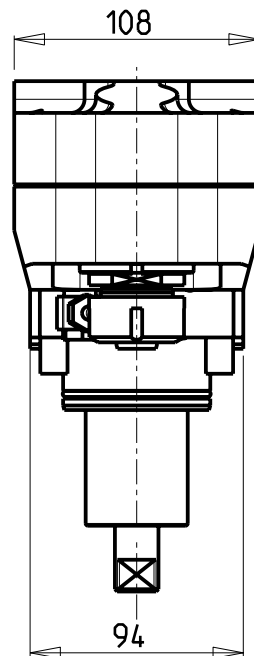
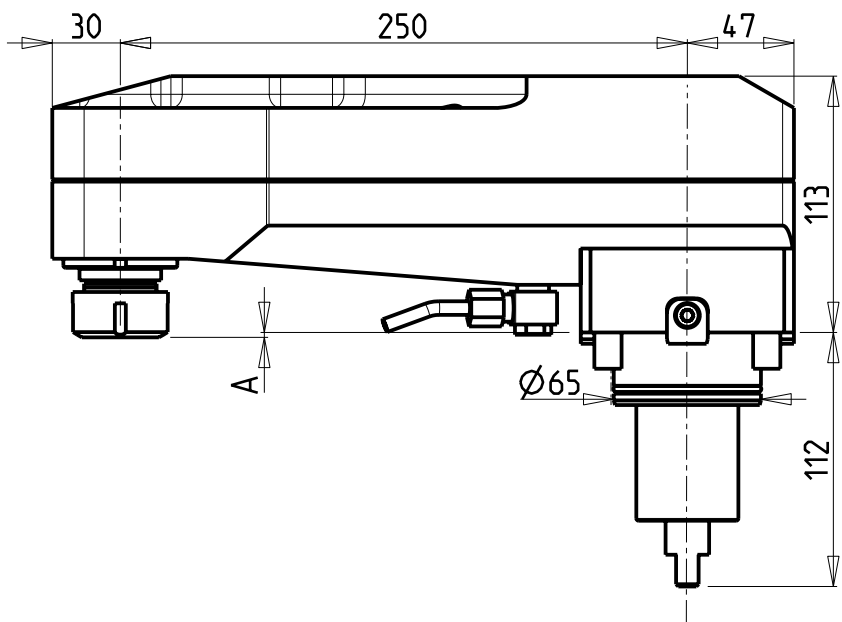

Cod. MT	Mandrino Spindle	I	RPM	Coppia Max Max Torque Max Drehmoment	Lubrificazione est. Ext. coolant Aussehenkuehlung	A	CHIAVI NON INCLUSE Keys not included Schlüssel nicht einbegriffen		
							CHSTER25	CHUB36	
0700025	ER25	1:2	12000	30Nm	X	2.16	CHSTER25	CHUB36	NEW
0700032	ER32	1:2	12000	30Nm	X	14.66	CHSTER32	CHUB36	NEW

## HW ACHEON

HI-TECH 200 - HI-TECH 300/400 - HI-TECH 450 - VT450 - T2 - CUTEX 240

MODULO MOTORIZZATO RADIALE ROVESCiato DISASSATO IN Z 250mm

Radial inverted driven tool re-directed in Z by 250mm

Radial angetriebenes Werkzeug ungekehrt achsversetzt in Z um 250mm

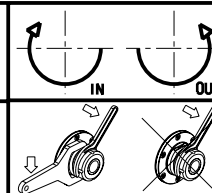

**M.T. srl**

Via Casino Albini 480  
Tel. 0541/956034-957884  
Fax 0541/956341

47842 S. GIOVANNI IN M. (RN)  
e-mail: mtma@mtmarchetti.com  
http://www.mtmarchetti.com

PRODUZIONE MODULI ROTANTI



PAGINA HW C120-2-10

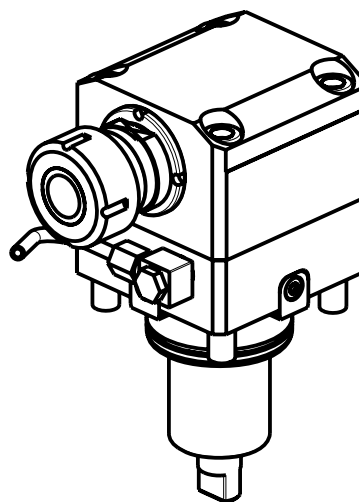
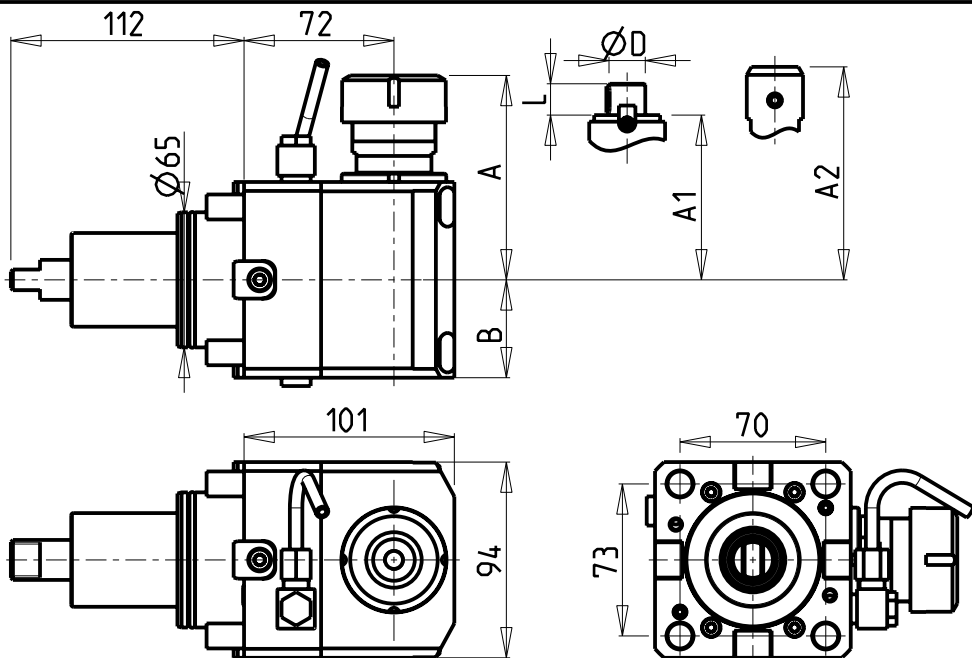

ATTENZIONE - ATTENTION - ACHTUNG

- FINO AD ESAURIMENTO SCORTE  
- clearance sale  
- solange vorrat

- Chiave inclusa
- Key included
- Schluessel inbegriffen

Cod. MT	Cod. EPPINGER	Mandrino Spindle Spindel	I	RPM	Coppia Max Max Torque Max Drehmoment	Reversibile lato mandrino/contromandrino Reversible sub/main spindte side Umkehrbare Spindel-seite/ Gegenspindel-seite	Lubr.interna Coolant through Innenkuehlung	Lubr.esterna Ext. coolant Aussenkuehlung	A	A1	A2	B	D	L	CHIAVI NON INCLUSE Keys not included Schluessel nicht einbegriffen		
0321432	7.070.678	ER32	1:1	6000	50Nm	X	-	X	98.16	-	-	47	-	-	CHSTER32	CHUB36	NEW
0321032	-	ER32	1:1	6000	50Nm	X	P=18bar	X	98.16	-	-	79	-	-	CHSTER32	CHUB36	NEW
0320022	-	WELDON 20	1:1	6000	50Nm	X	-	X	-	-	100	47	-	-	-	-	NEW
0321617	-	Ø16x17	1:1	6000	50Nm	X	-	X	-	61	-	47	16	17	CH_VTCROCE_M08	CHUB36	NEW
0322219	-	Ø22x19	1:1	6000	50Nm	X	-	X	-	62	-	47	22	19	CH_VTCROCE_M10	CHUB36	NEW
0322240	-	Ø22x40	1:1	6000	50Nm	X	-	X	-	62	-	47	22	40	CH_VTCROCE_M10	CHUB36	NEW
0322721	-	Ø27x21	1:1	6000	50Nm	X	-	X	-	64	-	47	27	21	CH_VTCROCE_M12	CHUB36	NEW
0322733	-	Ø27x33	1:1	6000	50Nm	X	-	X	-	64	-	47	27	33	CH_VTCROCE_M12	CHUB36	NEW
0322750	-	Ø27x50	1:1	6000	50Nm	X	-	X	-	64	-	47	27	50	CH_VTCROCE_M12	CHUB36	NEW

HW ACHEON  
 HI-TECH 200 - HI-TECH 300/400 - HI-TECH 450 - VT450 - CUTEX 240  
 MODULO MOTORIZZATO ASSIALE H=72mm  
 Axial driven tool H=72mm  
 Axial angetriebenes Werkzeug H=72mm

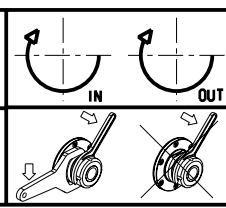

**M.T. srl**  
 Via Casino Albini 480  
 Tel. 0541/956034-957884  
 Fax 0541/956341  
 47842 S. GIOVANNI IN M. (RN)  
 e-mail: mtma@mtmarchetti.com  
 http://www.mtmarchetti.com

PRODUZIONE MODULI ROTANTI



PAGINA HW C 150-2-10

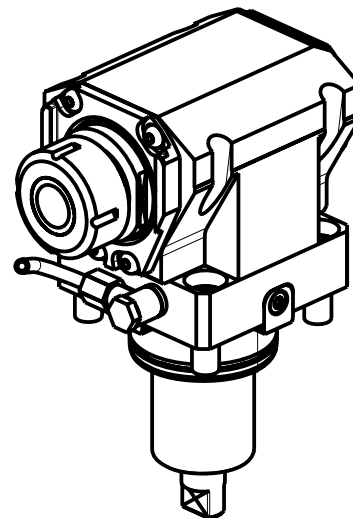
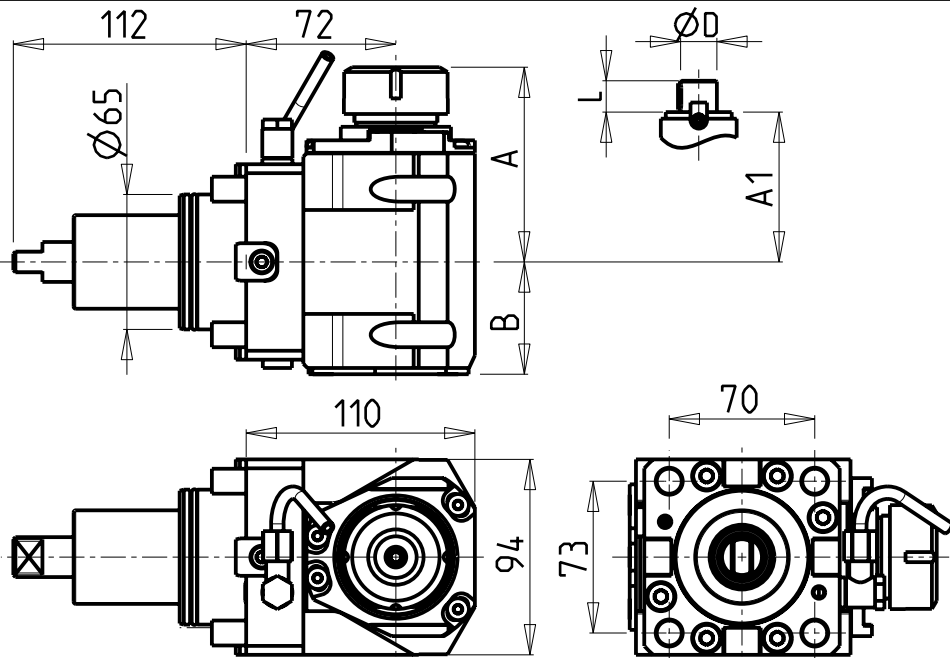

### ATTENZIONE - ATTENTION - ACHTUNG

- Per lo smontaggio degli utensili utilizzare sempre la chiave di contrasto come indicato nel manuale d'uso.
- For disassembly of the tools use always the contrast key as mentioned in the user instructions.
- Fuer das Abmontieren der Werkzeuge immer den Gegenschlüssel benutzen wie in der Bedienungsanleitung erwäehnt.

- Chiave inclusa
- Key included
- Schlüssel inbegriffen

Cod. MT	Mandrino Spindle Spindel	I	RPM	Coppia Max Max Torque Max Drehmoment	Reversibile lato mandrino/contromandrino Reversible sub/main spindle side Umkehrbare Spindel-seite/ Gegenspindel-seite	Lubr.interna Coolant through Innenkuehlung	Lubr.esterna Ext. coolant Aussenkuehlung	A	A1	B	D	L	CHIAVI NON INCLUSE Keys not included Schlüssel nicht einbegriffen		
DW 00700125	ER25	1:1	6000	70Nm	X		X	91.16	-	54	-	-	CHSTER25	OKU0650004	NEW
DW 00700225	ER25	1:1	6000	70Nm	X	P=70bar	X	91.16	-	65	-	-	CHSTER25	OKU0650004	NEW
DW 00700132	ER32	1:1	6000	70Nm	X		X	93.66	-	54	-	-	CHSTER32	OKU0650004	NEW
DW 00700232	ER32	1:1	6000	70Nm	X	P=70bar	X	93.66	-	65	-	-	CHSTER32	OKU0650004	NEW
DW 00700140	ER40	1:1	6000	70Nm	X		X	98.16	-	54	-	-	CHSTER40	OKU0650004	NEW
DW 00700240	ER40	1:1	6000	70Nm	X	P=70bar	X	98.16	-	65	-	-	CHSTER40	OKU0650004	NEW
DW 00700516	Ø16x17	1:1	6000	70Nm	X		X	-	67.5	54	16	17	CH_VTCROCE_M08	OKU0650004	NEW
DW 00700522	Ø22x19	1:1	6000	70Nm	X		X	-	67.5	54	22	19	CH_VTCROCE_M10	OKU0650004	NEW
DW 00700527	Ø27x21	1:1	6000	70Nm	X		X	-	70	54	27	21	CH_VTCROCE_M12	OKU0650004	NEW

HW ACHEON

HI-TECH 200 - HI-TECH 300/400 - HI-TECH 450 - VT450 - CUTEX 240

MODULO MOTORIZZATO ASSIALE H=72mm

Axial driven tool H=72mm

Axial angetriebenes Werkzeug H=72mm

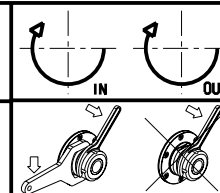

**M.T. srl**

Via Casino Albini 480  
Tel. 0541/956034-957884

Fax 0541/956341

47842 S. GIOVANNI IN M. (RN)

e-mail: mtma@mtmarchetti.com

http://www.mtmarchetti.com

PRODUZIONE MODULI ROTANTI



PAGINA HW C150-2-11

**ATTENZIONE - ATTENTION - ACHTUNG**

- Per lo smontaggio degli utensili utilizzare sempre la chiave di contrasto come indicato nel manuale d'uso.
- For disassembly of the tools use always the contrast key as mentioned in the user instructions.
- Fuer das Abmontieren der Werkzeuge immer den Gegenschlüssel benutzen wie in der Bedienungsanleitung erwäehnt.

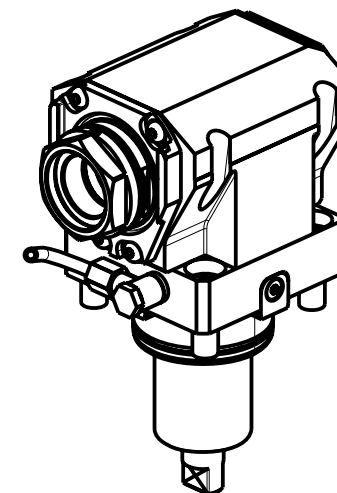
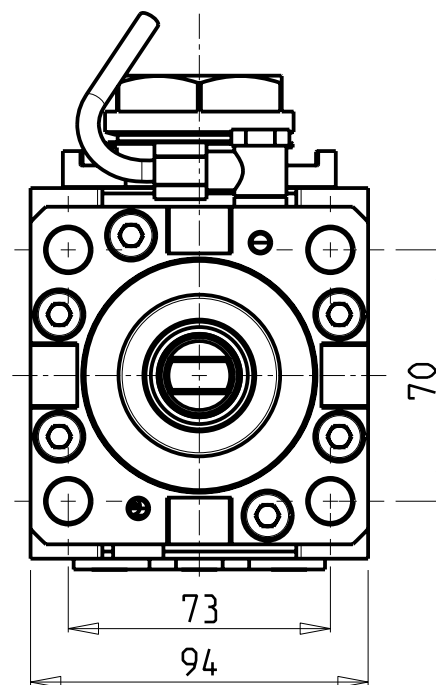
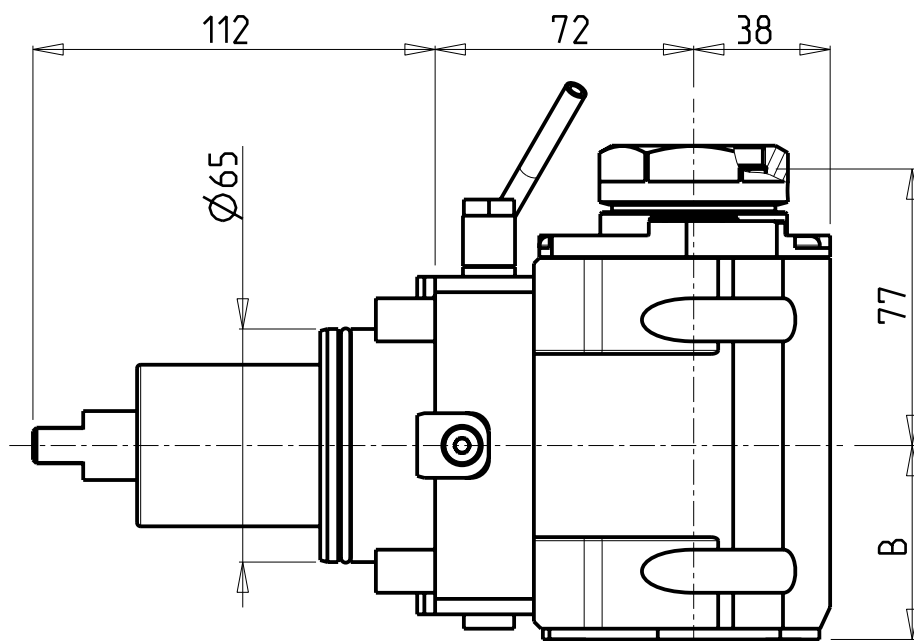

PER PORTAUTENSILI MODULARI MTSK-40 VEDI PAG. TBL300-1-40  
 FOR MTSK-40 QUIK CHANGE TOOLHOLDERS CLAMPINGS SEE PAGE TBL300-1-40  
 FUER MTSK-40 MODULARE WERKZEUGAUFNAHMEN SIEHE SEITE TBL300-1-40

Cod. MT	Mandrino Spindle Spindel	I	RPM	Coppia Max Max Torque Max Drehmoment	Reversibile lato mandrino/contromandrino Reversible sub/main spindle side Umkehrbare Spindel-seite/ Gegenspindel-seite	Lubr.interna Coolant through Innenkuehlung	Lubr.esterna Ext. coolant Ausseinkuehlung	B	CHIAVI NON INCLUSE Keys not included Schluesssel nicht einbegriffen	
DW01170140	MTSK-40	1:1	6000	70Nm	X		X	54	CHUB46	OKU0650004 •
DW01170240	MTSK-40	1:1	6000	70Nm	X	P=70bar	X	65	CHUB46	OKU0650004 •

- Chiave inclusa
- Key included
- Schluesssel inbegriffen

NEW  
NEW

HW ACHEON

HI-TECH 200 - HI-TECH 300/400 - HI-TECH 450 - VT450 - CUTEX 240

MODULO MOTORIZZATO ASSIALE MTSK H=72mm

Axial MTSK driven tool H=72mm

Axial MTSK angetriebenes Werkzeug H=72mm

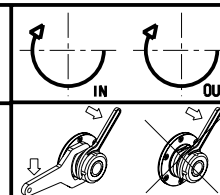

**M.T. srl**

Via Casino Albini 480  
 Tel. 0541/956034-957884  
 Fax 0541/956341

47842 S. GIOVANNI IN M. (RN)  
 e-mail: mtma@mtmarchetti.com  
 http://www.mtmarchetti.com

PRODUZIONE MODULI ROTANTI



PAGINA HWC150-2-11-K



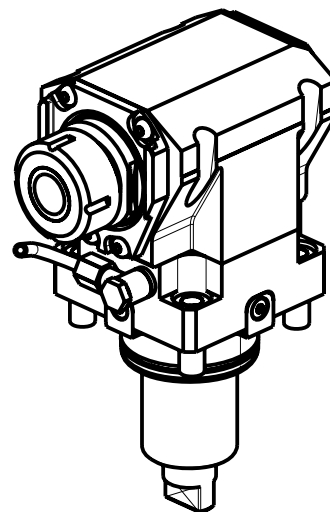
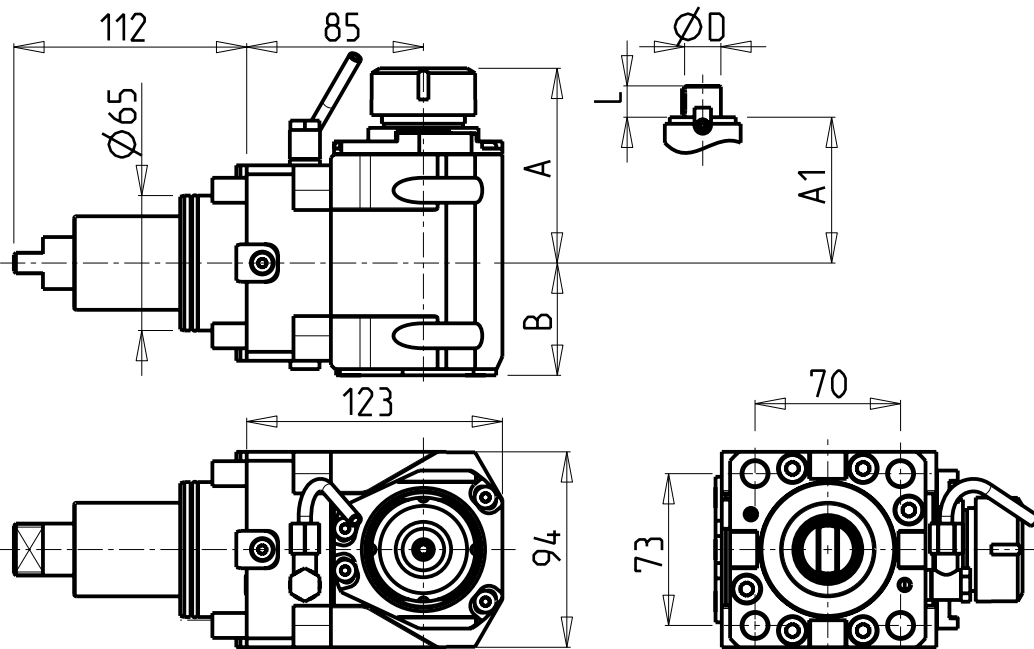

### ATTENZIONE - ATTENTION - ACHTUNG

- Per lo smontaggio degli utensili utilizzare sempre la chiave di contrasto come indicato nel manuale d'uso.
- For disassembly of the tools use always the contrast key as mentioned in the user instructions.
- Fuer das Abmontieren der Werkzeuge immer den Gegenschlüssel benutzen wie in der Bedienungsanleitung erwäehnt.

- Chiave inclusa
- Key included
- Schlüssel inbegriffen

Cod. MT	Mandrino Spindle Spindel	I	RPM	Coppia Max Max Torque Max Drehmoment	Reversibile lato mandrino/contromandrino Reversible sub/main spindle side Umkehrbare Spindel-seite/ Gegenspindel-seite	Lubr.interna Coolant through Innenkuehlung	Lubr.esterna Ext. coolant Aussenkuehlung	A	A1	B	D	L	CHIAVI NON INCLUSE Keys not included Schlüssel nicht einbegriffen		
DW 01130125	ER25	1:1	6000	70Nm	X		X	91.16	-	54	-	-	CHSTER25	OKU0650004	NEW
DW 01130225	ER25	1:1	6000	70Nm	X	P=70bar	X	91.16	-	65	-	-	CHSTER25	OKU0650004	NEW
DW 01130132	ER32	1:1	6000	70Nm	X		X	93.66	-	54	-	-	CHSTER32	OKU0650004	NEW
DW 01130232	ER32	1:1	6000	70Nm	X	P=70bar	X	93.66	-	65	-	-	CHSTER32	OKU0650004	NEW
DW 01130140	ER40	1:1	6000	70Nm	X		X	98.16	-	54	-	-	CHSTER40	OKU0650004	NEW
DW 01130240	ER40	1:1	6000	70Nm	X	P=70bar	X	98.16	-	65	-	-	CHSTER40	OKU0650004	NEW
DW 01130516	Ø16x17	1:1	6000	70Nm	X		X	-	67.5	54	16	17	CH_VTCROCE_M08	OKU0650004	NEW
DW 01130522	Ø22x19	1:1	6000	70Nm	X		X	-	67.5	54	22	19	CH_VTCROCE_M10	OKU0650004	NEW
DW 01130527	Ø27x21	1:1	6000	70Nm	X		X	-	70	54	27	21	CH_VTCROCE_M12	OKU0650004	NEW

### HW ACHEON

HI-TECH 300/400 - HI-TECH 450 - VT450 - CUTEX 240

MODULO MOTORIZZATO ASSIALE H=85mm

Axial driven tool H=85mm

Axial angetriebenes Werkzeug H=85mm

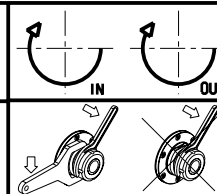

### M.T. srl

Via Casino Albini 480  
Tel. 0541/956034-957884  
Fax 0541/956341

47842 S. GIOVANNI IN M. (RN)  
e-mail: mtma@mtmarchetti.com  
http://www.mtmarchetti.com

PRODUZIONE MODULI ROTANTI



PAGINA HW C 150-2-15

**ATTENZIONE - ATTENTION - ACHTUNG**

- Per lo smontaggio degli utensili utilizzare sempre la chiave di contrasto come indicato nel manuale d'uso.
- For disassembly of the tools use always the contrast key as mentioned in the user instructions.
- Fuer das Abmontieren der Werkzeuge immer den Gegenschlüssel benutzen wie in der Bedienungsanleitung erwaeht.

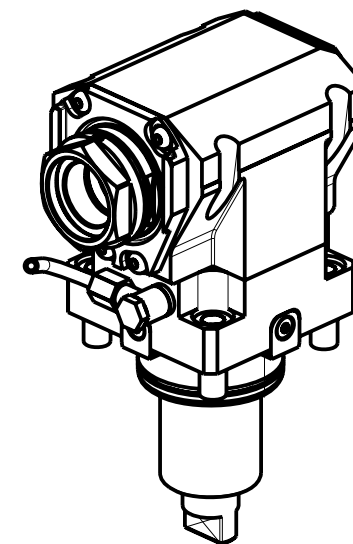
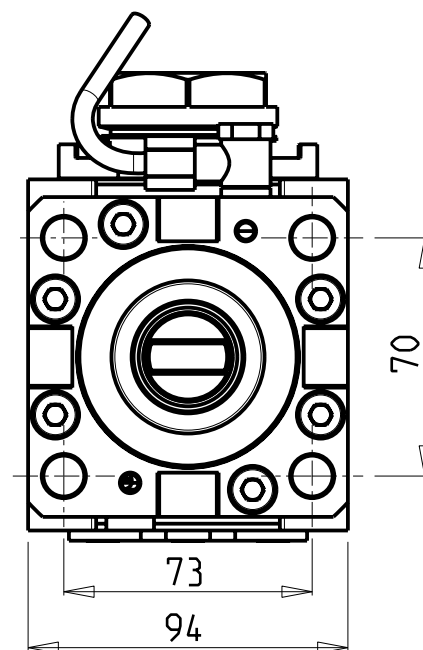
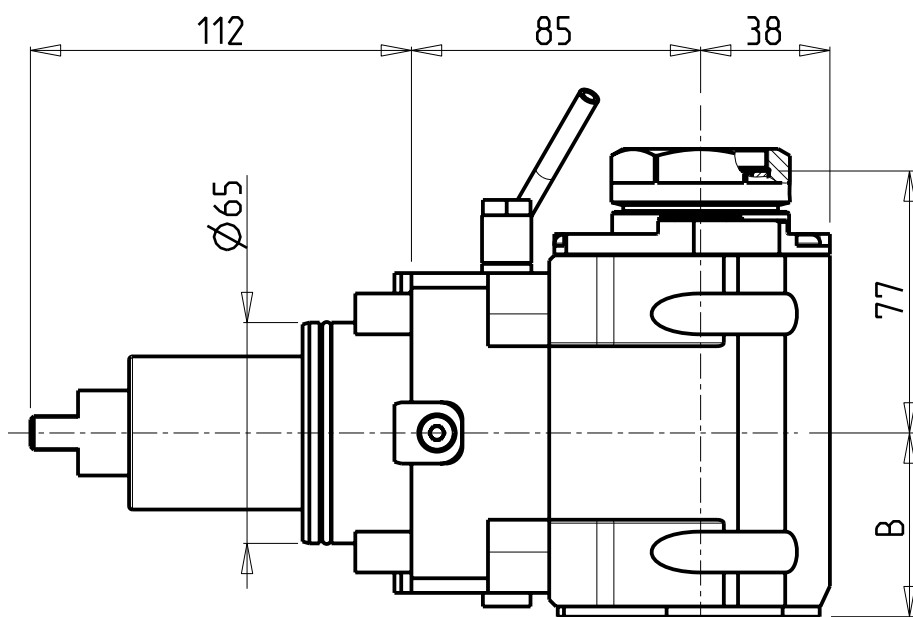

PER PORTAUTENSILI MODULARI MTSK-40 VEDI PAG. TBL300-1-40  
 FOR MTSK-40 QUICK CHANGE TOOLHOLDERS CLAMPINGS SEE PAGE TBL300-1-40  
 FUER MTSK-40 MODULARE WERKZEUGAUFNAHMEN SIEHE SEITE TBL300-1-40

Cod. MT	Mandrino Spindle Spindel	I	RPM	Coppia Max Max Torque Max Drehmoment	Reversibile lato mandrino/contromandrino Reversible sub/main spindle side Umkehrbare Spindel-seite/Gegenspindel-seite	Lubr.interna Coolant through Innenkuehlung	Lubr.esterna Ext. coolant Ausseinkuehlung	B	CHIAVI NON INCLUSE Keys not included Schlüssel nicht einbegriffen	
DW01180140	MTSK-40	1:1	6000	70Nm	X		X	54	CHUB46	OKU0650004 •
DW01180240	MTSK-40	1:1	6000	70Nm	X	P=70bar	X	65	CHUB46	OKU0650004 •

- Chiave inclusa
- Key included
- Schlüssel inbegriffen

NEW  
NEW

**HW ACHEON**

HI-TECH 300/400 - HI-TECH 450 - VT450 - CUTEX 240

MODULO MOTORIZZATO ASSIALE MTSK H=85mm

Axial MTSK driven tool H=85mm

Axial MTSK angetriebenes Werkzeug H=85mm

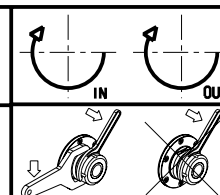

**M.T. srl**

Via Casino Albini 480  
 Tel. 0541/956034-957884  
 Fax 0541/956341  
 47842 S. GIOVANNI IN M. (RN)  
 e-mail: mtma@mtmarchetti.com  
 http://www.mtmarchetti.com

PRODUZIONE MODULI ROTANTI



PAGINA HW C 150-2-15-K

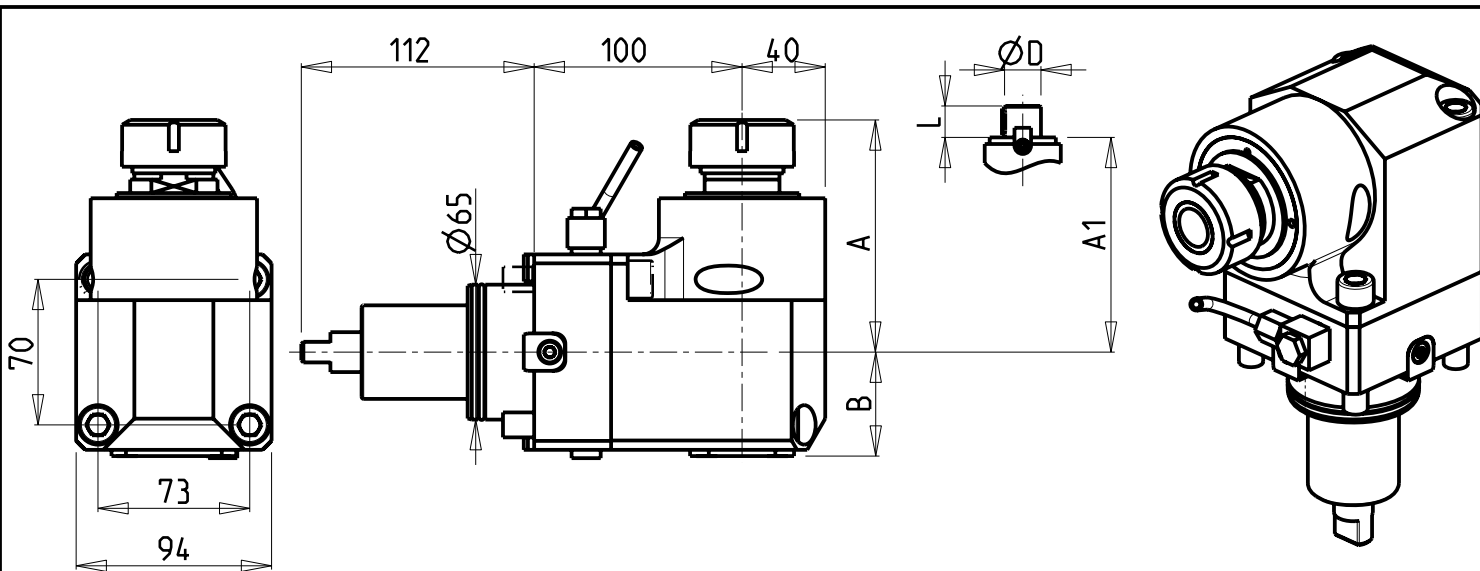

**ATTENZIONE - ATTENTION - ACHTUNG**

- Per lo smontaggio degli utensili utilizzare sempre la chiave di contrasto come indicato nel manuale d'uso.
- For disassembly of the tools use always the contrast key as mentioned in the user instructions.
- Fuer das Abmontieren der Werkzeuge immer den Gegenschlüssel benutzen wie in der Bedienungsanleitung erwaeht.

- Chiave inclusa
- Key included
- Schlüssel inbegriffen

Cod. MT	Mandrino Spindle	I	RPM	Coppia Max Max Torque Max Drehmoment	Reversibile lato mandrino/contromandrino Reversible sub/main spindle side Umkehrbare Spindelseite/ Gegenspindelseite	Lubr.interna Coolant through Innenkuehlung	Lubr.esterna Ext. coolant Aussenkuehlung	A	A1	B	D	L	CHIAVI NON INCLUDE Keys not included Schluessel nicht einbegriffen		
0711432	ER32	1:1	6000	70Nm	X		X	111.56	-	47	-	-	CHSTER32	CHUB36	NEW
0711032	ER32	1:1	6000	70Nm	X	P=70bar	X	111.56	-	72	-	-	CHSTER32	CHUB36	NEW
0711532	ER A 32	1:1	6000	70Nm	X		X	102.03	-	47	-	-	CHUB50	CHUB32	NEW
0712640	ER40	1:1	6000	70Nm	X		X	115	-	47	-	-	CHSTER40	CHUB46	NEW
0712540	ER40	1:1	6000	70Nm	X	P=70bar	X	115	-	72	-	-	CHSTER40	CHUB46	NEW
0711617	Ø16x17	1:1	6000	70Nm	X		X	-	86	47	16	17	CH_VTCROCE_M08	CHUB36	NEW
0712219	Ø22x19	1:1	6000	70Nm	X		X	-	88	47	22	19	CH_VTCROCE_M10	CHUB36	NEW
0712240	Ø22x40	1:1	6000	70Nm	X		X	-	86	47	22	40	CH_VTCROCE_M10	CHUB36	NEW
0712721	Ø27x21	1:1	6000	70Nm	X		X	-	87.5	47	27	21	CH_VTCROCE_M12	CHUB36	NEW
0712733	Ø27x33	1:1	6000	70Nm	X		X	-	86	47	27	33	CH_VTCROCE_M12	CHUB36	NEW
0712750	Ø27x50	1:1	6000	70Nm	X		X	-	86	47	27	50	CH_VTCROCE_M12	CHUB36	NEW

<b>HW ACHEON</b> HI-TECH 300/400 - HI-TECH 450 - VT450 - T2 - CUTEX 240 MODULO MOTORIZZATO ASSIALE H=100mm Axial driven tool H=100mm Axial angetriebenes Werkzeug H=100mm		<b>M.T. srl</b> Via Casino Albini 480 Tel. 0541/956034-957884 Fax 0541/956341 47842 S. GIOVANNI IN M. (RN) e-mail: mtma@mtmarchetti.com http://www.mtmarchetti.com	PRODUZIONE MODULI ROTANTI 

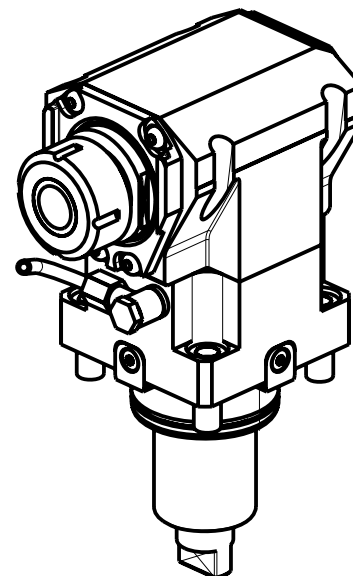
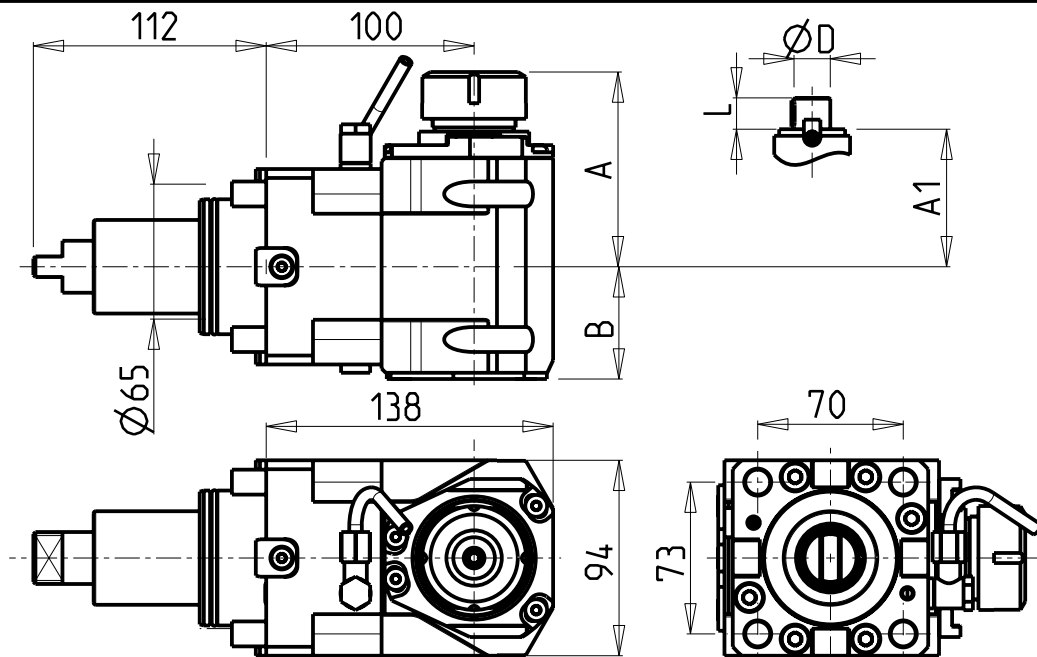

### ATTENZIONE - ATTENTION - ACHTUNG

- Per lo smontaggio degli utensili utilizzare sempre la chiave di contrasto come indicato nel manuale d'uso.
- For disassembly of the tools use always the contrast key as mentioned in the user instructions.
- Fuer das Abmontieren der Werkzeuge immer den Gegenschlüssel benutzen wie in der Bedienungsanleitung erwaeht.

- Chiave inclusa
- Key included
- Schlüssel inbegriffen

Cod. MT	Mandrino Spindle Spindel	I	RPM	Coppia Max Max Torque Max Drehmoment	Reversibile lato mandrino/contromandrino Reversible sub/main spindle side Umkehrbare Spindel-seite/ Gegenspindel-seite	Lubr.interna Coolant through Innenkuehlung	Lubr.esterna Ext. coolant Aussenkuehlung	A	A1	B	D	L	CHIAVI NON INCLUSE Keys not included Schlüssel nicht einbegriffen		
DW 01140125	ER25	1:1	6000	70Nm	X		X	91.16	-	54	-	-	CHSTER25	OKU0650004	NEW
DW 01140225	ER25	1:1	6000	70Nm	X	P=70bar	X	91.16	-	65	-	-	CHSTER25	OKU0650004	NEW
DW 01140132	ER32	1:1	6000	70Nm	X		X	93.66	-	54	-	-	CHSTER32	OKU0650004	NEW
DW 01140232	ER32	1:1	6000	70Nm	X	P=70bar	X	93.66	-	65	-	-	CHSTER32	OKU0650004	NEW
DW 01140140	ER40	1:1	6000	70Nm	X		X	98.16	-	54	-	-	CHSTER40	OKU0650004	NEW
DW 01140240	ER40	1:1	6000	70Nm	X	P=70bar	X	98.16	-	65	-	-	CHSTER40	OKU0650004	NEW
DW 01140516	Ø16x17	1:1	6000	70Nm	X		X	-	67.5	54	16	17	CH_VTCROCE_M08	OKU0650004	NEW
DW 01140522	Ø22x19	1:1	6000	70Nm	X		X	-	67.5	54	22	19	CH_VTCROCE_M10	OKU0650004	NEW
DW 01140527	Ø27x21	1:1	6000	70Nm	X		X	-	70	54	27	21	CH_VTCROCE_M12	OKU0650004	NEW

### HW ACHEON

HI-TECH 300/400 - HI-TECH 450 - VT450 - T2 - CUTEX 240

MODULO MOTORIZZATO ASSIALE H=100mm

Axial driven tool H=100mm

Axial angetriebenes Werkzeug H=100mm

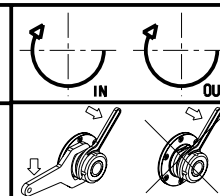

### M.T. srl

Via Casino Albini 480  
Tel. 0541/956034-957884

Fax 0541/956341

47842 S. GIOVANNI IN M. (RN)

e-mail: mtma@mtmarchetti.com

http://www.mtmarchetti.com

PRODUZIONE MODULI ROTANTI



PAGINA HW C 150-2-21

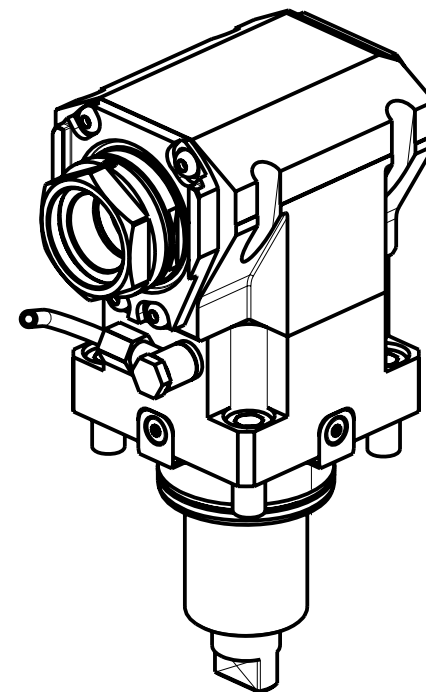
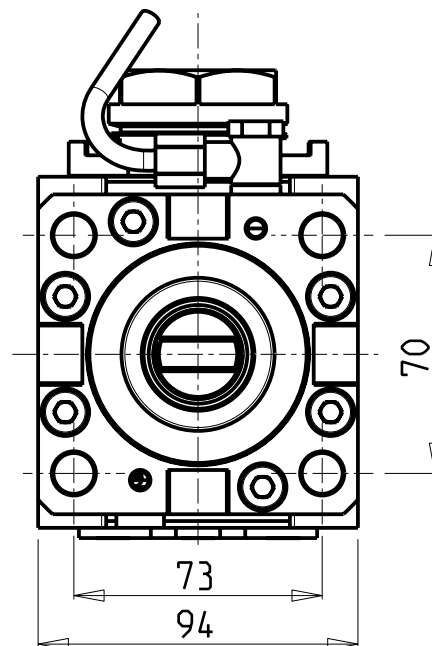
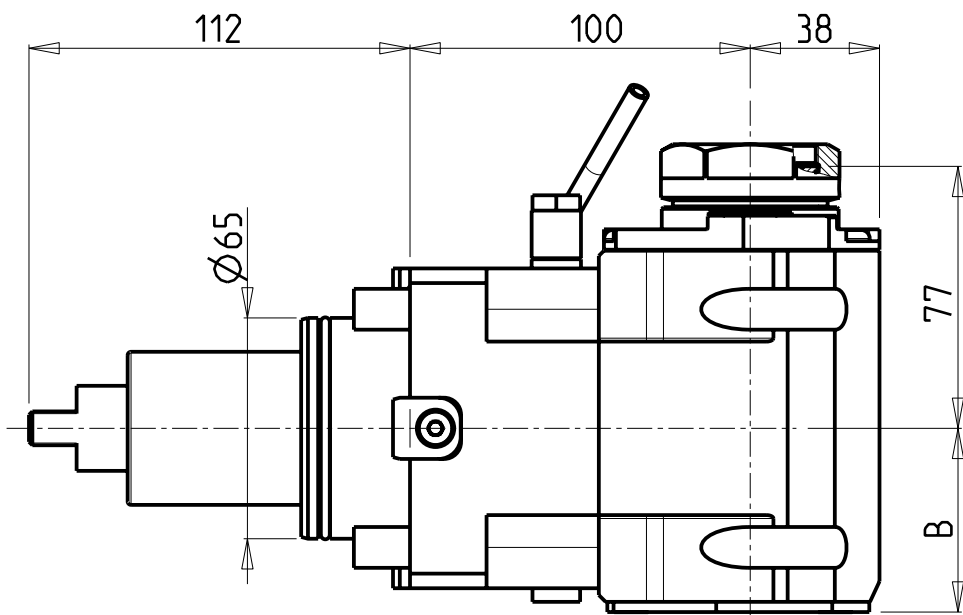

PER PORTAUTENSILI MODULARI MTSK-40 VEDI PAG. TBL300-1-40  
 FOR MTSK-40 QUICK CHANGE TOOLHOLDERS CLAMPINGS SEE PAGE TBL300-1-40  
 FUER MTSK-40 MODULARE WERKZEUGAUFNAHMEN SIEHE SEITE TBL300-1-40

Cod. MT	Mandrino Spindle Spindel	I	RPM	Coppia Max Max Torque Max Drehmoment	Reversibile lato mandrino/contromandrino Reversible sub/main spindle side Umkehrbare Spindel-seite/ Gegenspindel-seite	Lubr.interna Coolant through Innenkuehlung	Lubr.esterna Ext. coolant Ausseinkuehlung	B	CHIAVI NON INCLUSE Keys not included Schluessel nicht einbegriffen	
DW01190140	MTSK-40	1:1	6000	70Nm	X		X	54	CHUB46	OKU0650004 •
DW01190240	MTSK-40	1:1	6000	70Nm	X	P=70bar	X	65	CHUB46	OKU0650004 •

- Chiave inclusa
- Key included
- Schluessel inbegriffen

NEW  
NEW

HW ACHEON  
 HI-TECH 300/400 - HI-TECH 450 - VT450 - T2 - CUTEX 240

MODULO MOTORIZZATO ASSIALE MTSK H=100mm  
 Axial MTSK driven tool H=100mm  
 Axial MTSK angetriebenes Werkzeug H=100mm

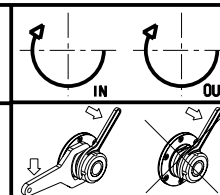

**M.T. srl**  
 Via Casino Albini 480  
 Tel. 0541/956034-957884  
 Fax 0541/956341  
 47842 S. GIOVANNI IN M. (RN)  
 e-mail: mtma@mtmarchetti.com  
 http://www.mtmarchetti.com

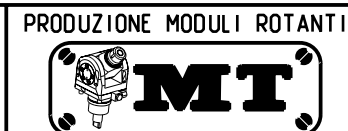

PAGINA HWC150-2-21-K

**ATTENZIONE - ATTENTION - ACHTUNG**

- Per lo smontaggio degli utensili utilizzare sempre la chiave di contrasto come indicato nel manuale d'uso.
- For disassembly of the tools use always the contrast key as mentioned in the user instructions.
- Fuer das Abmontieren der Werkzeuge immer den Gegenschlüssel benutzen wie in der Bedienungsanleitung erwäehnt.

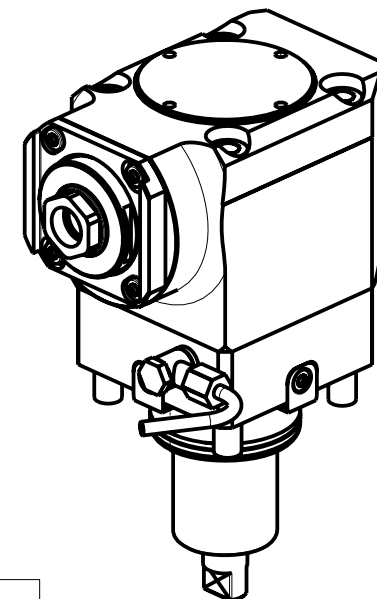
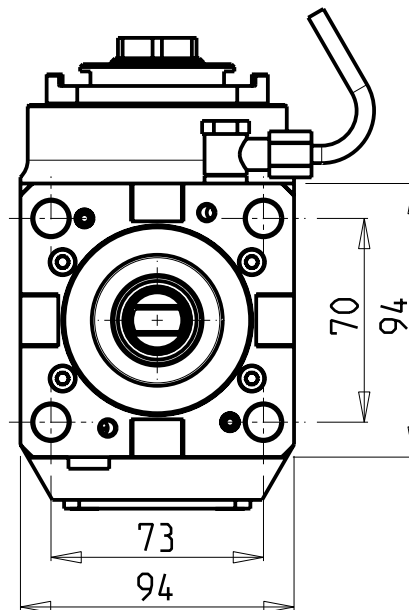
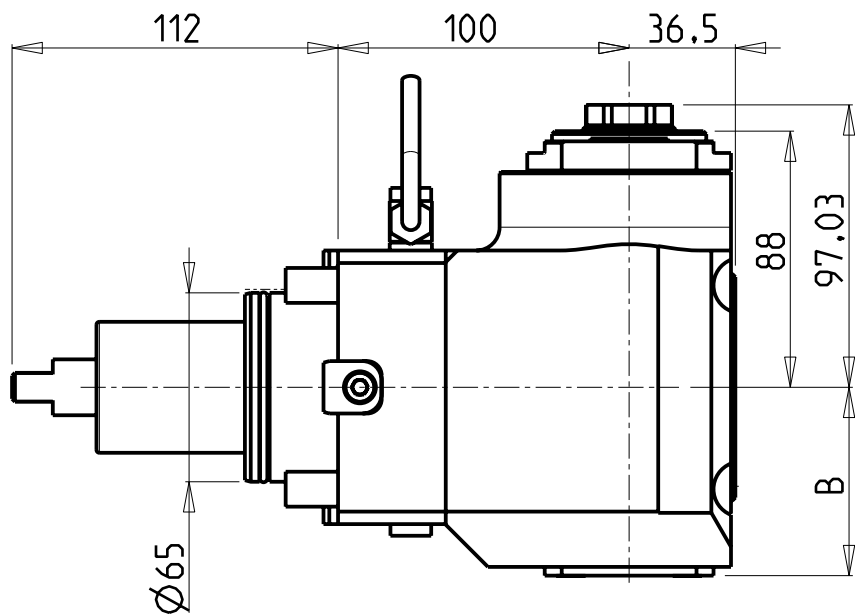

Cod. MT	Mandrino Spindle Spindel	I	RPM	Coppia Max Max Torque Max Drehmoment	Reversibile lato mandrino/contromandrino Reversible sub/main spindle side Umkehrbare Spindel-seite/ Gegenspindel-seite	Lubrificazione int. Coolant through Innenkuehlung	Lubrificazione est. Ext. coolant Aussenkuehlung	B	CHIAVI NON INCLUSE Keys not included Schlüssel nicht einbegriffen	
DW00710125	ER A 25	1:2	12000	30Nm	X		X	64.7	OKU0650004	CHUB27
DW00710225	ER A 25	1:2	12000	30Nm	X	P=70bar	X	73.2	OKU0650004	CHUB27

NEW  
NEW

- Chiave inclusa
- Key included
- Schlüssel inbegriffen

**HW ACHEON**

HI-TECH 300/400 - HI-TECH 450 - VT450 - T2 - CUTEX 240

MODULO MOTORIZZATO ASSIALE MOLTIPLICATO I=1:2

Axial geared-up I=1:2 driven tool

Axial angetriebenes Werkzeug uebersetzt I=1:2

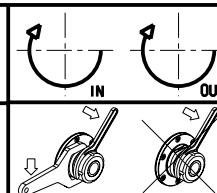

**M.T. srl**

Via Casino Albini 480  
Tel. 0541/956034-957884  
Fax 0541/956341

47842 S. GIOVANNI IN M. (RN)  
e-mail: mtma@mtmarchetti.com  
http://www.mtmarchetti.com

PRODUZIONE MODULI ROTANTI



PAGINA HWC200-2-20

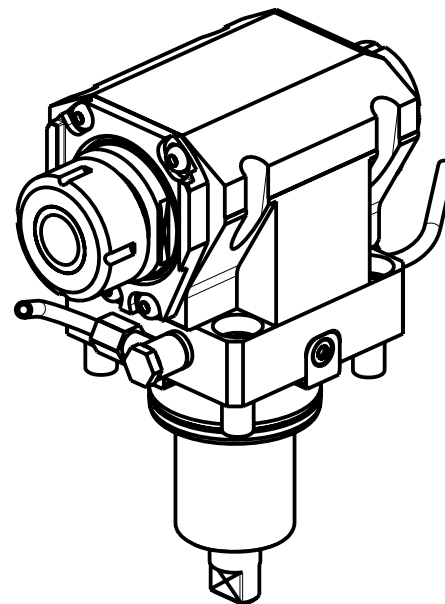
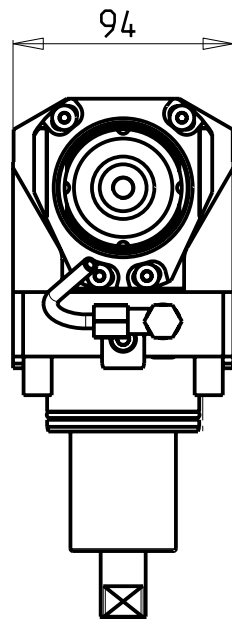
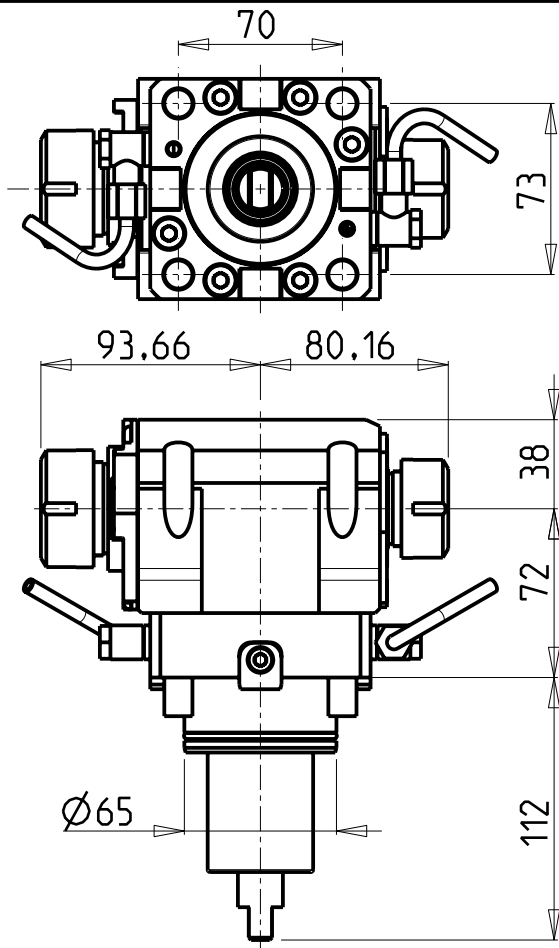

### ATTENZIONE - ATTENTION - ACHTUNG

- Per lo smontaggio degli utensili utilizzare sempre la chiave di contrasto come indicato nel manuale d'uso.
- For disassembly of the tools use always the contrast key as mentioned in the user instructions.
- Fuer das Abmontieren der Werkzeuge immer den Gegenschlüssel benutzen wie in der Bedienungsanleitung erwahnt.

Cod. MT	Mandrino Spindle Spindel	I	RPM	Coppia Max Max Torque Max Drehmoment	Reversibile lato mandrino/contromandrino Reversible sub/main spindle side Umkehrbare Spindel-seite/ Gegenspindel-seite	Lubr.esterna Ext. coolant Aussenkuehlung	CHIAVI NON INCLUSE Keys not included Schluesssel nicht einbegriffen		
DW00720132	ER32+ER25	1:1	6000	70Nm	X	X	CHSTER32	CHSTER25	OKU0650004 • NEW

- Chiave inclusa
- Key included
- Schluesssel inbegriffen

### HW ACHEON

HI-TECH 200 - HI-TECH 300/400 - HI-TECH 450 - VT450 - CUTEX 240

MODULO MOTORIZZATO ASSIALE BISPORGENTE H=72mm

Axial opposite face driven tool H=72mm

Axial angetriebenes Werkzeug halb vorspringend H=72mm

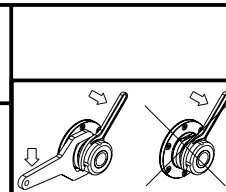

### M.T. srl

Via Casino Albini 480  
Tel. 0541/956034-957884

Fax 0541/956341

47842 S. GIOVANNI IN M. (RN)

e-mail: mtma@mtmarchetti.com

http://www.mtmarchetti.com

PRODUZIONE MODULI ROTANTI



PAGINA HW C240-2-10

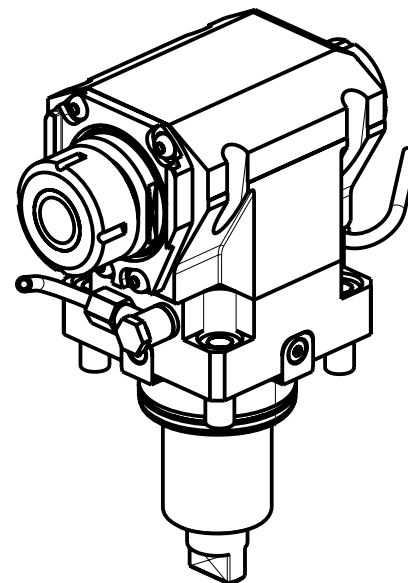
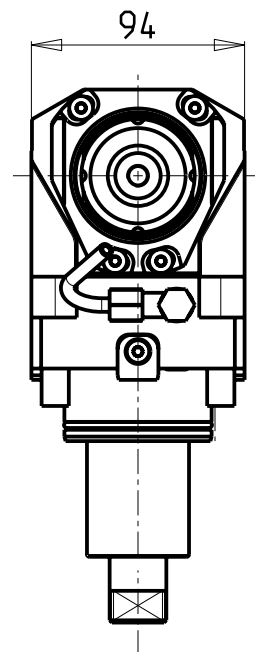
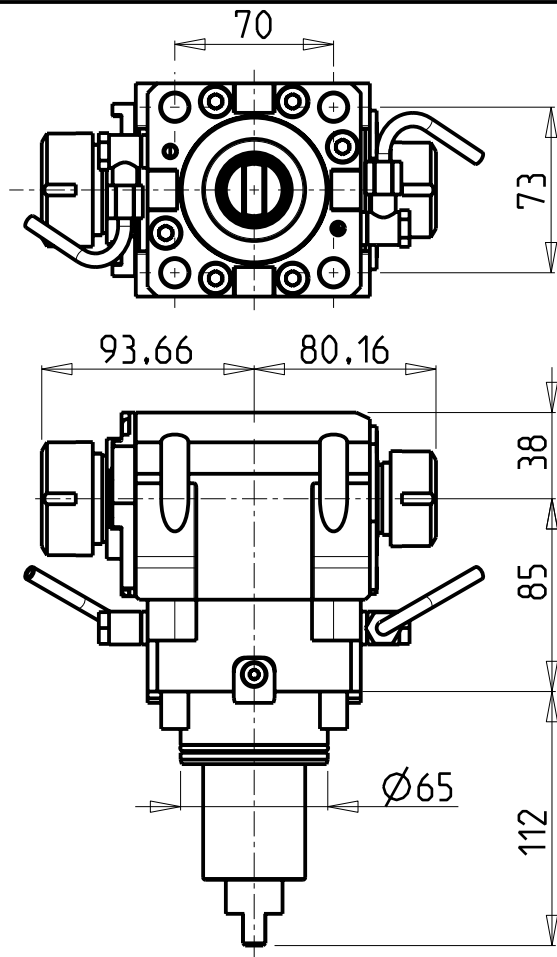

### ATTENZIONE - ATTENTION - ACHTUNG

- Per lo smontaggio degli utensili utilizzare sempre la chiave di contrasto come indicato nel manuale d'uso.
- For disassembly of the tools use always the contrast key as mentioned in the user instructions.
- Fuer das Abmontieren der Werkzeuge immer den Gegenschlüssel benutzen wie in der Bedienungsanleitung erwäehnt.

Cod. MT	Mandrino Spindle Spindel	I	RPM	Coppia Max Max Torque Max Drehmoment	Reversibile lato mandrino/contromandrino Reversible sub/main spindle side Umkehrbare Spindelseite/ Gegenspindelseite	Lubr.esterna Ext. coolant Aussenkuehlung	CHIAVI NON INCLUSE Keys not included Schluessel nicht einbegriffen			
DW01150132	ER32+ER25	1:1	6000	70Nm	X	X	CHSTER32	CHSTER25	OKU0650004	NEW

- Chiave inclusa
- Key included
- Schluessel inbegriffen

### HW ACHEON

HI-TECH 300/400 - HI-TECH 450 - VT450 - CUTEX 240

MODULO MOTORIZZATO ASSIALE BISPORGENTE H=85mm

Axial opposite face driven tool H=85mm

Axial angetriebenes Werkzeug halb vorspringend H=85mm

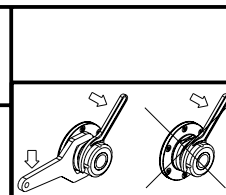

### M.T. srl

Via Casino Albini 480  
Tel. 0541/956034-957884  
Fax 0541/956341

47842 S. GIOVANNI IN M. (RN)  
e-mail: mtma@mtmarchetti.com  
http://www.mtmarchetti.com

PRODUZIONE MODULI ROTANTI



PAGINA HW C240-2-15



**ATTENZIONE - ATTENTION - ACHTUNG**

- Per lo smontaggio degli utensili utilizzare sempre la chiave di contrasto come indicato nel manuale d'uso.
- For disassembly of the tools use always the contrast key as mentioned in the user instructions.
- Fuer das Abmontieren der Werkzeuge immer den Gegenschlüssel benutzen wie in der Bedienungsanleitung erwähnt.

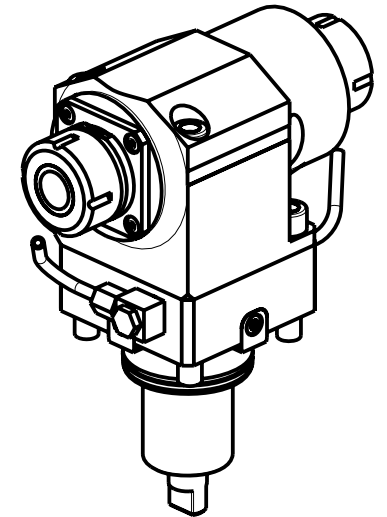
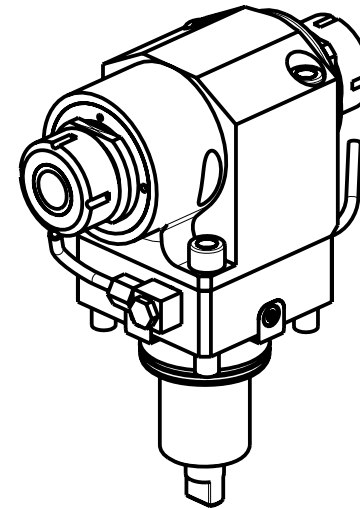
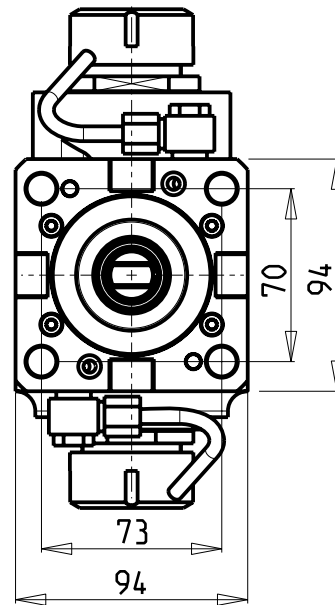
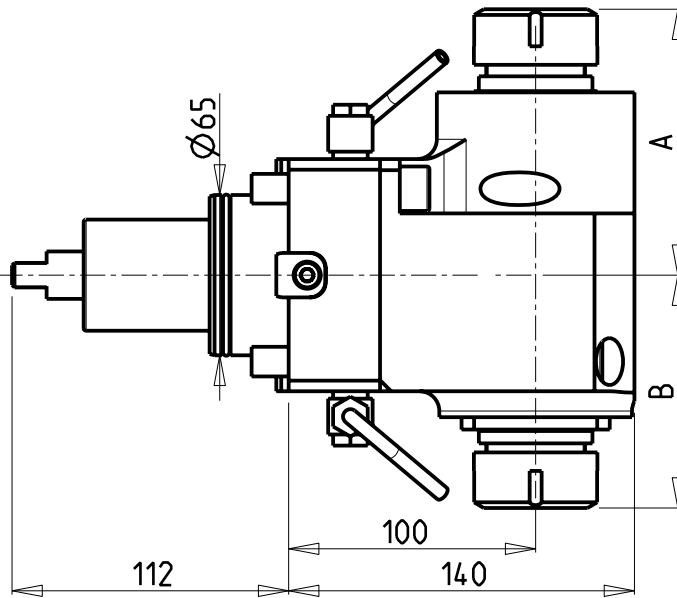

Cod. MT	Mandrino Spindle Spindel	I	RPM	Coppia Max Max Torque Max Drehmoment	Reversibile lato mandrino/contromandrino Reversible sub/main spindle side Umkehrbare Spindel-seite/ Gegenspindel-seite	Lubrificazione est. Ext. coolant Aussenkuehlung	A	B	CHIAVI NON INCLUSE Keys not included Schlüssel nicht einbegriffen		
									CHSTER32	CHUB46	
DW 00070232	ER32+ER32	1:1	6000	70Nm	X	X	107.66	94.26	CHSTER32	CHUB46	
DW 00073225	ERA25+ERA32	1:1	6000	70Nm	X	X	106.03	81.13	CHUB27	CHUB32	CHUB46

NEW

NEW

**HW ACHEON**

HI-TECH 300/400 - HI-TECH 450 - VT450 - T2 - CUTEX 240

MODULO MOTORIZZATO ASSIALE BISPORGENTE H=100mm

Axial opposite face twin driven tool H=100mm

Axial angetriebenes Werkzeug halb vorspringend H=100mm

**M.T. srl**

Via Casino Albini 480  
Tel. 0541/956034-957884  
Fax 0541/956341  
47842 S. GIOVANNI IN M. (RN)  
e-mail: mtma@mtmarchetti.com  
http://www.mtmarchetti.com

PRODUZIONE MODULI ROTANTI



PAGINA HWC240-2-20

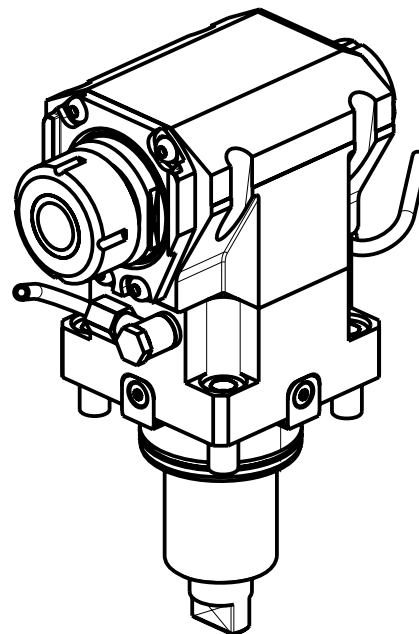
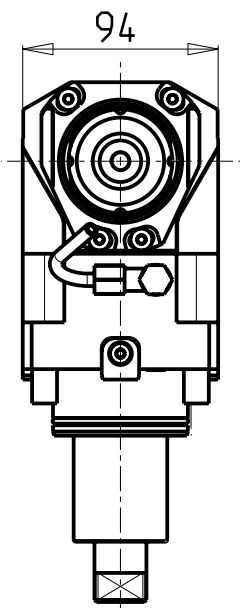
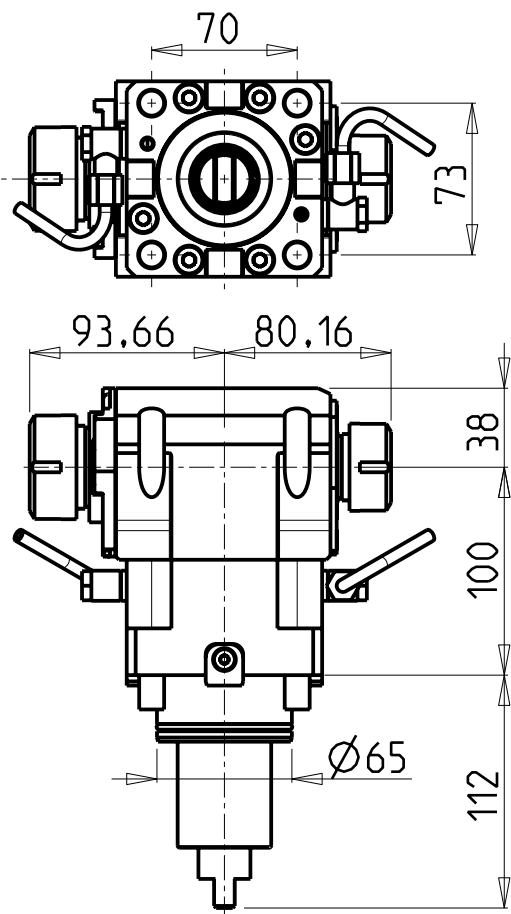

### ATTENZIONE - ATTENTION - ACHTUNG

- Per lo smontaggio degli utensili utilizzare sempre la chiave di contrasto come indicato nel manuale d'uso.
- For disassembly of the tools use always the contrast key as mentioned in the user instructions.
- Fuer das Abmontieren der Werkzeuge immer den Gegenschlüssel benutzen wie in der Bedienungsanleitung erwäehnt.

Cod. MT	Mandrino Spindle Spindel	I	RPM	Coppia Max Max Torque Max Drehmoment	Reversibile lato mandrino/contromandrino Reversible sub/main spindle side Umkehrbare Spindel-seite/ Gegenspindel-seite	Lubr.esterna Ext. coolant Aussenkuehlung	CHIAVI NON INCLUSE Keys not included Schluessel nicht einbegriffen			
DW01160132	ER32+ER25	1:1	6000	70Nm	X	X	CHSTER32	CHSTER25	OKU0650004	NEW

- Chiave inclusa
- Key included
- Schluessel inbegriffen

### HW ACHEON

HI-TECH 300/400 - HI-TECH 450 - VT450 - T2 - CUTEX 240

MODULO MOTORIZZATO ASSIALE BISPORGENTE H=100mm

Axial opposite face driven tool H=100mm

Axial angetriebenes Werkzeug halb vorspringend H=100mm

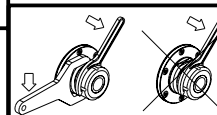

### M.T. srl

Via Casino Albini 480  
Tel. 0541/956034-957884  
Fax 0541/956341

47842 S. GIOVANNI IN M. (RN)  
e-mail: mtma@mtmarchetti.com  
http://www.mtmarchetti.com

PRODUZIONE MODULI ROTANTI



PAGINA HWC240-2-21

### ATTENZIONE - ATTENTION - ACHTUNG

- Per lo smontaggio degli utensili utilizzare sempre la chiave di contrasto come indicato nel manuale d'uso.
- For disassembly of the tools use always the contrast key as mentioned in the user instructions.
- Fuer das Abmontieren der Werkzeuge immer den Gegenschlüssel benutzen wie in der Bedienungsanleitung erwäehnt.

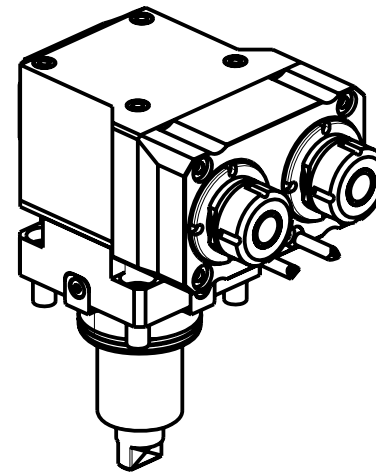
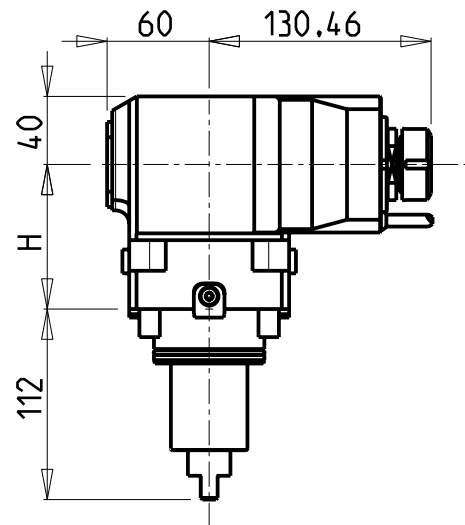
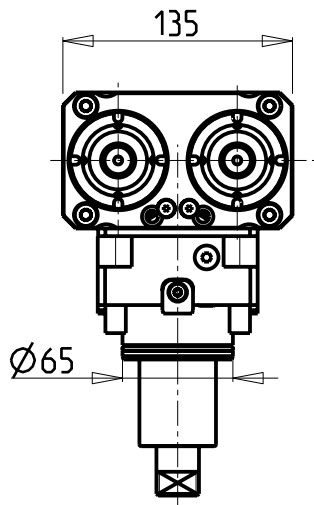
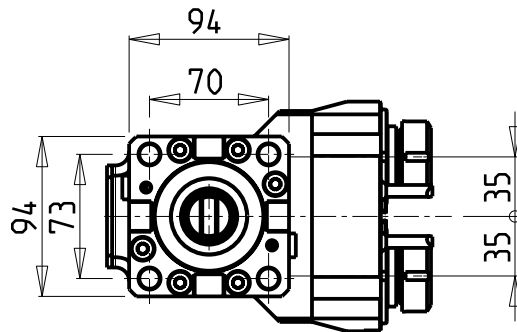

Cod. MT	Mandrino Spindle Spindel	I	RPM	Coppia Max Max Torque Max Drehmoment	Reversibile lato mandrino/contromandrino Reversible sub/main spindle side Umkehrbare Spindel-seite/ Gegenspindel-seite	Lubrificazione est. Ext. coolant Aussenkuehlung	H	Tipo Macchine Machine type Maschinen typ	CHIAVI NON INCLUSE Keys not included Schlüssel nicht einbegriffen		
									CHUB36	CHSTER25	
DW 01120225	ER25	1:1	6000	40Nm	X	X	72	HI-TECH 450 YMC (BMT65)	CHUB36	CHSTER25	NEW
DW 01230225	ER25	1:1	6000	40Nm	X	X	100	T2	CHUB36	CHSTER25	NEW

HW ACHEON

HI-TECH 450 - T2

MODULO MOTORIZZATO ASSIALE 2 USCITE IN Y

Axial single side twin head driven tool in Y

Axial angetriebenes Werkzeug 2 Ausgaenge in Y

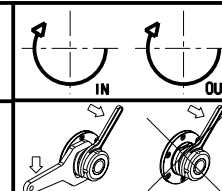

**M.T. srl**

Via Casino Albini 480  
Tel. 0541/956034-957884

Fax 0541/956341

47842 S. GIOVANNI IN M. (RN)

e-mail: mtma@mtmarchetti.com

http://www.mtmarchetti.com

PRODUZIONE MODULI ROTANTI



PAGINA HW C260-2-10

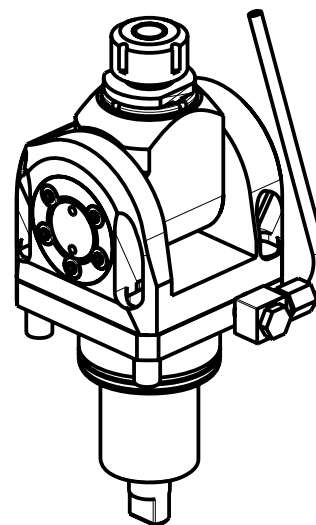
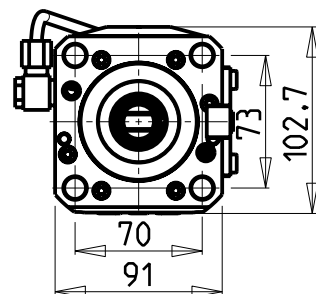
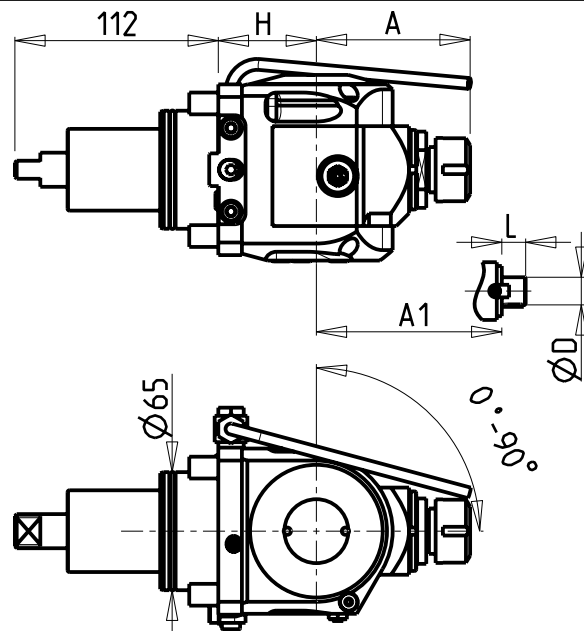

### ATTENZIONE - ATTENTION - ACHTUNG

- VERIFICARE LE MISURE DI INGOMBRO PER POSSIBILE INTERFERENZA SU ALCUNI MODELLI DI MACCHINE
- Please check the overall sizes for possible interferences on some machine models
- Bitte überprüfen sie das ausmass um mögliche interferenzen auf einigen maschinen modellen zu vermeiden

Cod. MT	Mandrino Spindle Spindel	I	RPM	Coppia Max Max Torque Max Drehmoment	Reversibile lato mandrino/contromandrino Reversible sub/main spindle side Umkehrbare Spindel-seite/ Gegenspindel-seite	Lubr.esterna Ext. coolant Aussenkuehlung	H	A	A1	D	L	CHIAVI INCLUSE Keys included Schluessel inbegriffen			
												CHSTER	CHUB36	CHESL10	
0370020	ER20	1:1	6000	40Nm	X	X	54	84.66	-	-	-	CHSTER20	CHUB36	CHESL10	NEW
0370120	ER20	1:1	6000	40Nm	X	X	100	84.66	-	-	-	CHSTER20	CHUB36	CHESL10	NEW
0370025	ER25	1:1	6000	40Nm	X	X	54	85.66	-	-	-	CHSTER25	CHUB36	CHESL10	NEW
0370125	ER25	1:1	6000	40Nm	X	X	100	85.66	-	-	-	CHSTER25	CHUB36	CHESL10	NEW
0371617	Ø16x17	1:1	6000	40Nm	X	X	54	-	65	16	17	CH_VTCROCE_M08	CHUB36	CHESL10	NEW
0372617	Ø16x17	1:1	6000	40Nm	X	X	100	-	65	16	17	CH_VTCROCE_M08	CHUB36	CHESL10	NEW
0372219	Ø22x19	1:1	6000	40Nm	X	X	54	-	66	22	19	CH_VTCROCE_M10	CHUB36	CHESL10	NEW
0373219	Ø22x19	1:1	6000	40Nm	X	X	100	-	66	22	19	CH_VTCROCE_M10	CHUB36	CHESL10	NEW
0371905	Ø3/4"x3/4"	1:1	6000	40Nm	X	X	54	-	65	3/4"	3/4"	CH_VTCROCE_M08	CHUB36	CHESL10	NEW
0372905	Ø3/4"x3/4"	1:1	6000	40Nm	X	X	100	-	65	3/4"	3/4"	CH_VTCROCE_M08	CHUB36	CHESL10	NEW

HW ACHEON

HI-TECH 200 - HI-TECH 300/400 - HI-TECH 450 - VT450 - T2 - CUTEX 240

MODULO MOTORIZZATO ORIENTABILE 0-90°

0-90° adjustable angle driven tool

Angetriebenes Werkzeug schwenkbar 0-90°

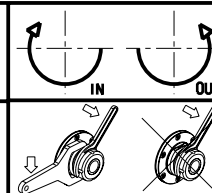

**M.T. srl**

Via Casino Albini 480  
Tel. 0541/956034-957884

Fax 0541/956341

47842 S. GIOVANNI IN M. (RN)  
e-mail: mtma@mtmarchetti.com  
http://www.mtmarchetti.com

PRODUZIONE MODULI ROTANTI



PAGINA HW C330-2-00

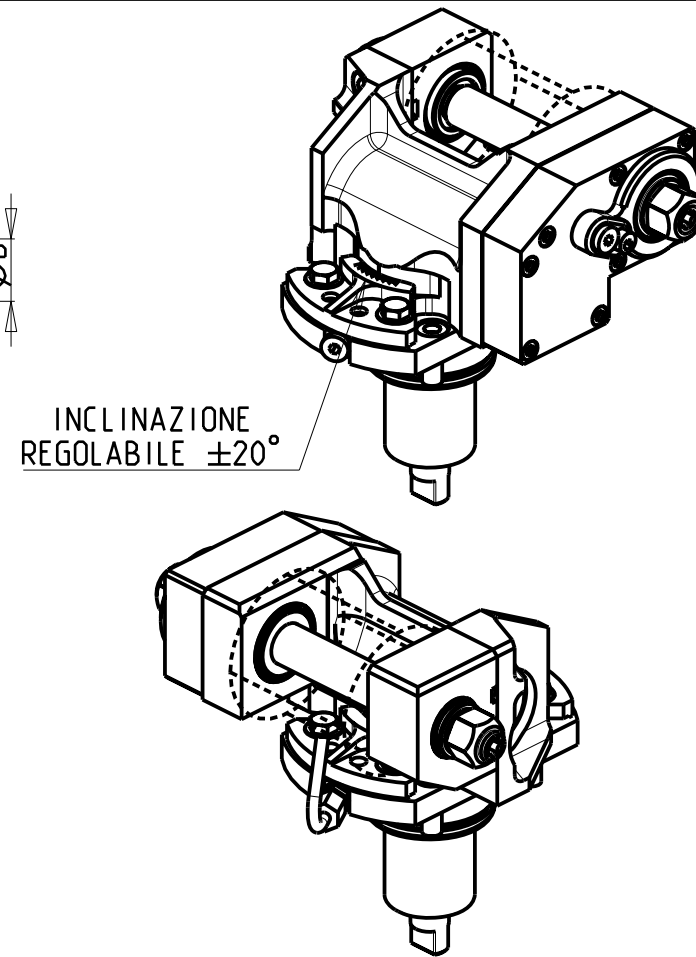
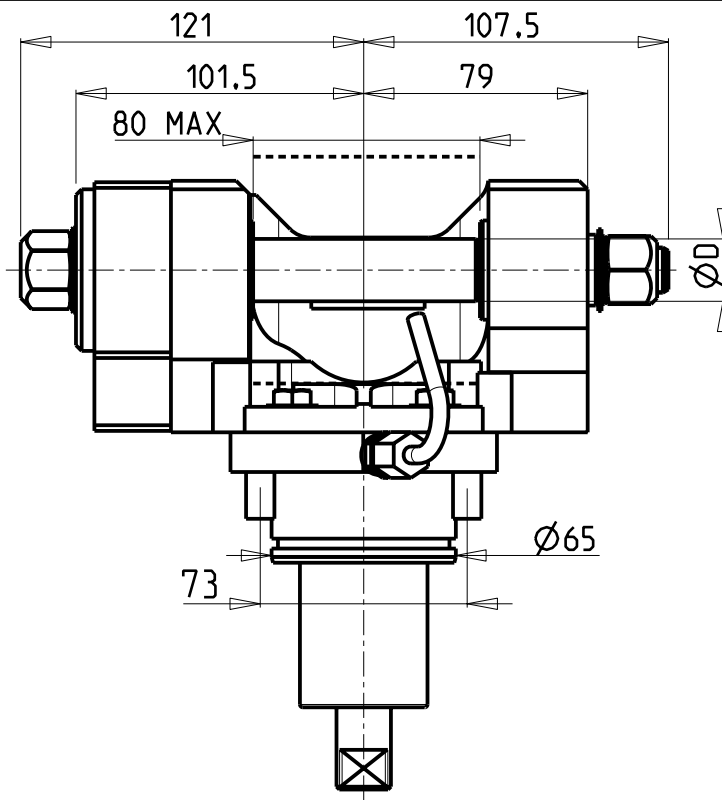
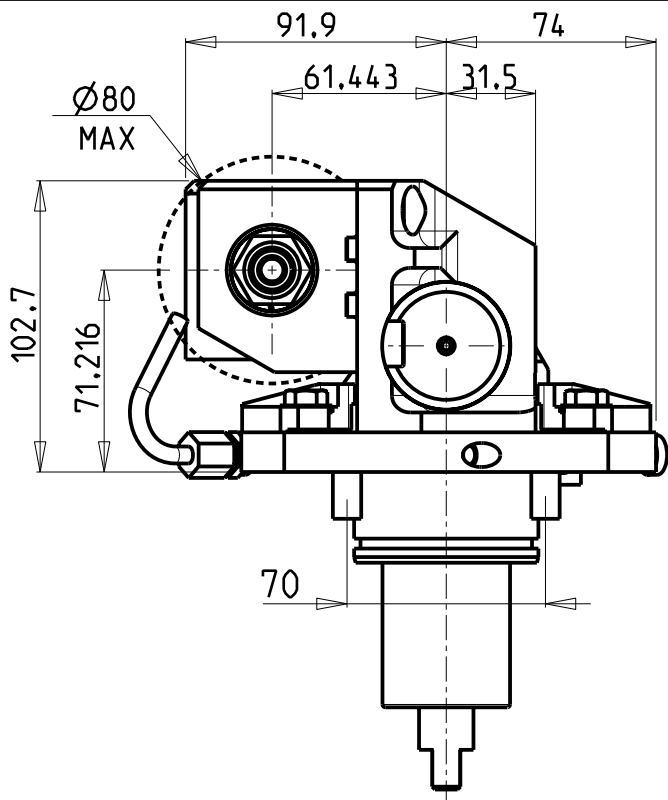

**DOTAZIONI - SUPPLIED WITH - AUSSTATTUNG**

- mm / inch
- N°1 ALBERO + DISTANZIALI
  - N°1 SHAFT + SPACER
  - N°1 DORN + ABSTANDSSTUECK

PER ALBERI E DISTANZIALI VEDI PAG. TBL250-1-00  
 FOR SHAFT END SPACER SEE PAGE TBL250-1-00  
 FUER DORN UND ABSTANDSSTUECK SEITE TBL250-1-00

Cod. MT	I	RPM	Coppia Max Max Torque Max Drehmoment	Reversibile lato mandrino/contromandrino Reversible sub/main spindle side Umkehrbare Spindel-seite/ Gegenspindel-seite	Lubrificazione est. Ext. coolant Aussenkuehlung	D (mm)	D (Inch)	CHIAVI INCLUSE Keys included Schlüssel inbegriffen			
								CHUB24	CHUB13	CHESL08	
0321100	1:1	6000	60Nm	X	X	16-22-27-32	3/4"-1"-1 1/4"	CHUB24	CHUB13	CHESL08	NEW
0322100	2:1	3000	80Nm	X	X	16-22-27-32	3/4"-1"-1 1/4"	CHUB24	CHUB13	CHESL08	NEW

**HW ACHEON**

HI-TECH 200 - HI-TECH 300/400 - HI-TECH 450 - VT450 - T2 - CUTEX 240

MODULO MOTORIZZATO PORTACREATORE

Driven gear hobber

Angetriebenes Zahnradwaelzfraes-Werkzeug

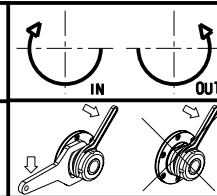

**M.T. srl**

Via Casino Albini 480  
 Tel. 0541/956034-957884  
 Fax 0541/956341

47842 S. GIOVANNI IN M. (RN)  
 e-mail: mtma@mtmarchetti.com  
 http://www.mtmarchetti.com

PRODUZIONE MODULI ROTANTI



PAGINA HWC340-2-00

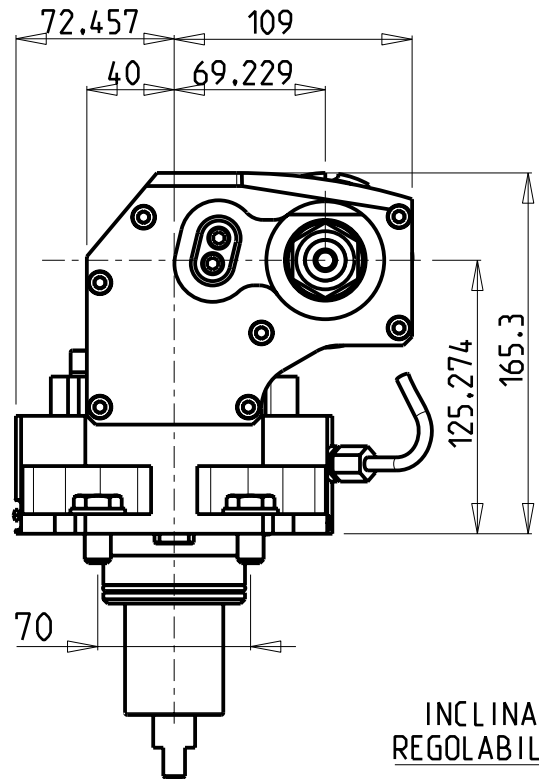
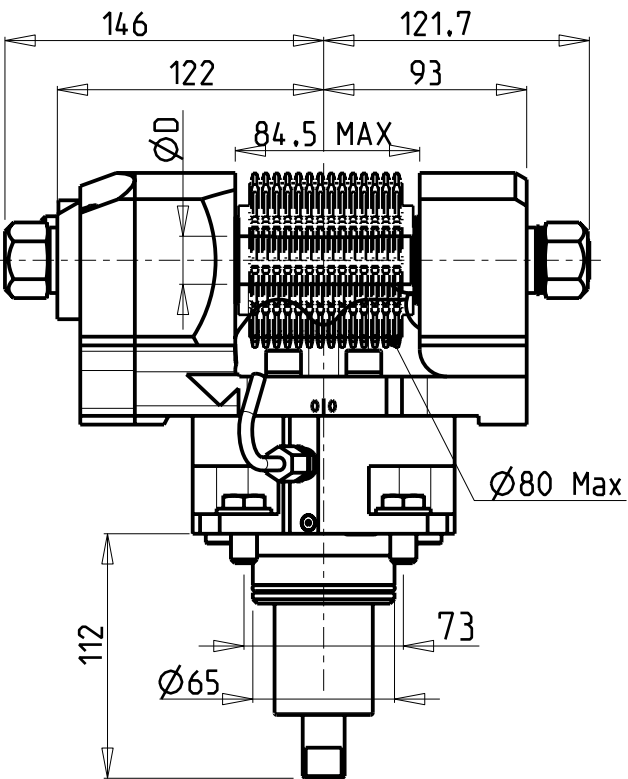

INCLINAZIONE  
REGOLABILE ±30°

**ATTENZIONE - ATTENTION - ACHTUNG**

- VERIFICARE LE MISURE DI INGOMBRO PER POSSIBILE INTERFERENZA SU ALCUNI MODELLI DI MACCHINE
- Please check the overall sizes for possible interferences on some machine models
- Bitte überprüfen sie das ausmass um mögliche interferenzen auf einigen maschinen modellen zu vermeiden

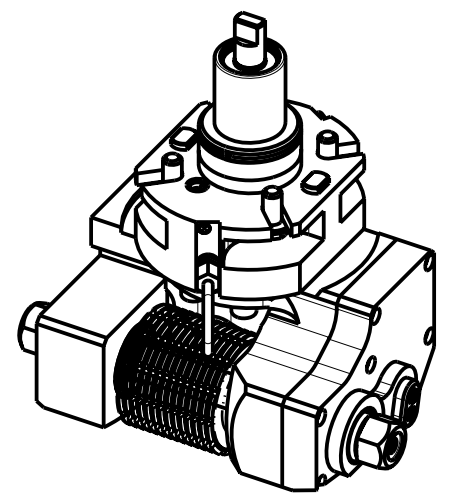
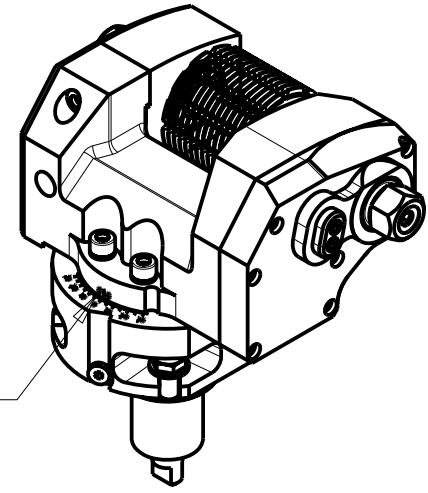

**DOTAZIONI - SUPPLIED WITH - AUSSTATTUNG**

mm / inch

- N°1 ALBERO + DISTANZIALI
- N°1 SHAFT + SPACER
- N°1 DORN + ABSTANDSSTUECK

PER ALBERI E DISTANZIALI VEDI PAG. TBL250-1-00  
FOR SHAFT END SPACER SEE PAGE TBL250-1-00  
FUER DORN UND ABSTANDSSTUECK SEITE TBL250-1-00

Cod. MT	I	RPM	Coppia Max Max Torque Max Drehmoment	Lubrificazione est. Ext. coolant Aussenkuehlung	D (mm)	D (Inch)	CHIAVI INCLUSE Keys included Schlüssel inbegriffen				
							CHUB30	CHUB19	CHESL08	CHUB24 (Ø16 / Ø3/4")	
DW 00031100	1:1	6000	90Nm	X	16-22-27-32	3/4"-1"-1 1/4"	CHUB30	CHUB19	CHESL08	CHUB24 (Ø16 / Ø3/4")	NEW
DW 00032100	2:1	3000	110Nm	X	16-22-27-32	3/4"-1"-1 1/4"	CHUB30	CHUB19	CHESL08	CHUB24 (Ø16 / Ø3/4")	NEW

**HW ACHEON**  
 HI-TECH 200 - HI-TECH 300/400 - HI-TECH 450 - VT450 - T2 - CUTEX 240  
 MODULO MOTORIZZATO PORTACREATORE MAGGIORATO  
 Reinforced driven gear hobber  
 Angetriebenes Zahnradwaelzfraes-Werkzeug vergroessert

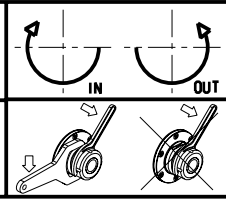

**M.T. srl**  
 Via Casino Albini 480  
 Tel. 0541/956034-957884  
 Fax 0541/956341  
 47842 S. GIOVANNI IN M. (RN)  
 e-mail: mtma@mtmarchetti.com  
 http://www.mtmarchetti.com

PRODUZIONE MODULI ROTANTI

PAGINA HWC340-2-60

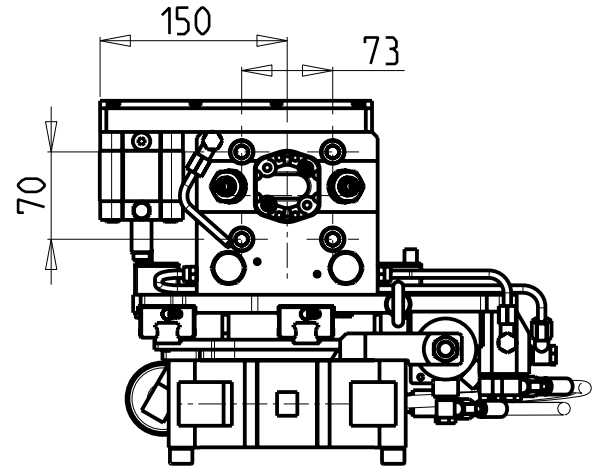
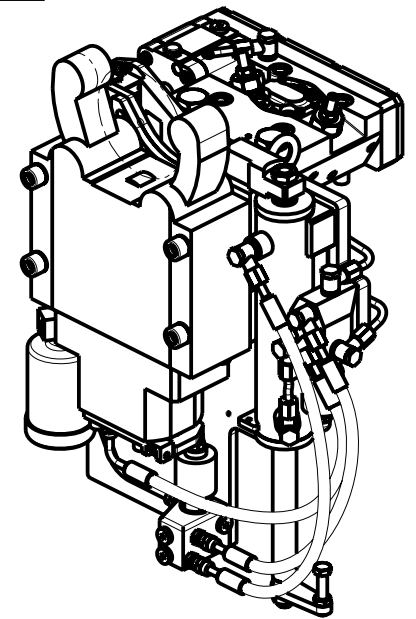
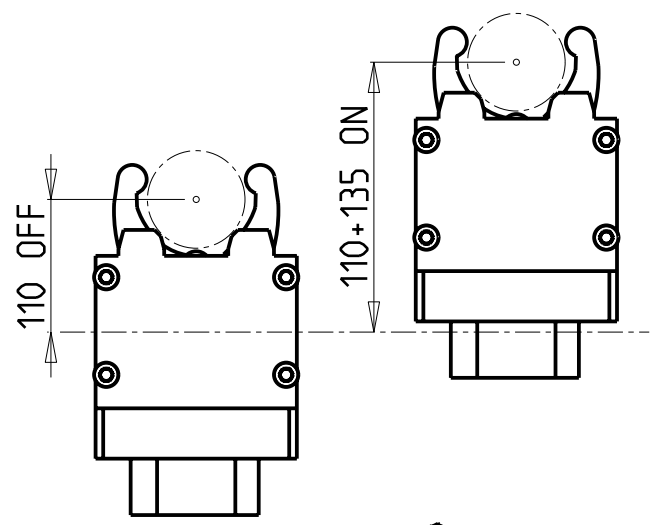
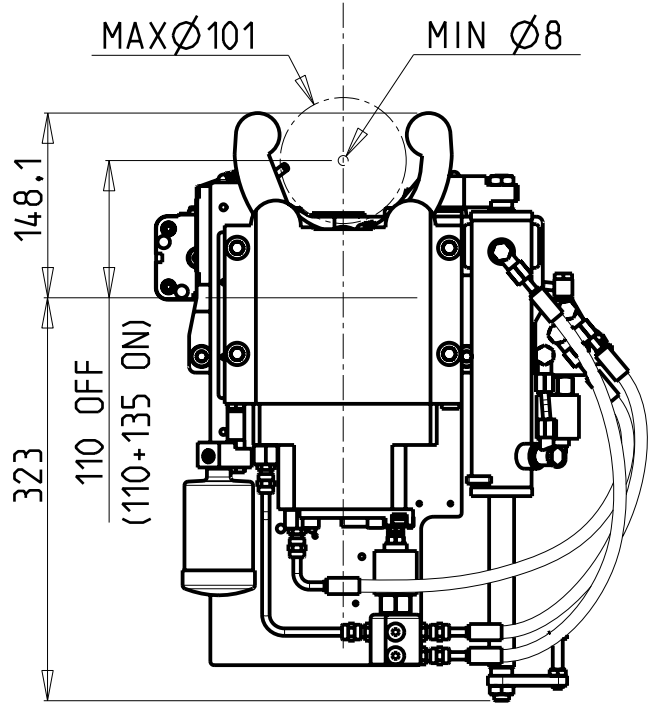
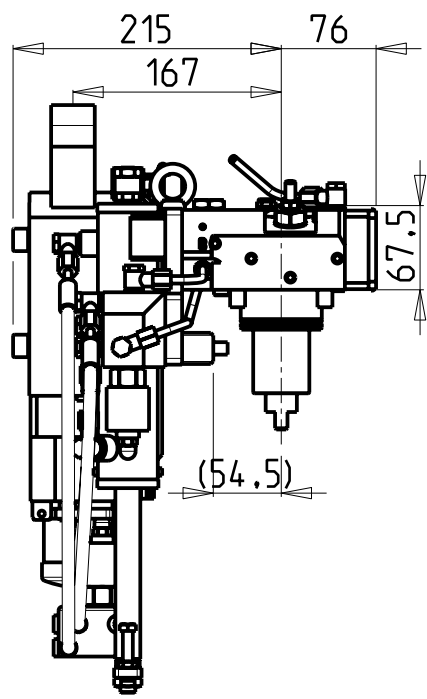

- #  CON GESTIONE ELETTRONICA APERTURA COMPLETA DELLA LUNETTA
- # With Electronic control of steady rest arms complete opening
- # Mit vollständiger elektronischer Öffnungsbedienung der Luenette

Cod. MT	I	RPM	Lubr. esterna Ext. coolant Aussenkuehlung	
DW00940300	1:1	6000	X	NEW
# DW00940300A	1:1	6000	X	NEW

HW ACHEON

MOD: T2

MODULO MOTORIZZATO PER LUNETTA RETRATTILE (TAGLIA 2)

Driven toolholder for sliding steady rest (Size 2)

Luenettenwerkzeug zurueck versetzte Version (Groesse 2)

**M.T. srl**  
 Via Casino Albini 480  
 Tel. 0541/956034-957884  
 Fax 0541/956341  
 47842 S. GIOVANNI IN M. (RN)  
 e-mail: mtma@mtmarchetti.com  
 http://www.mtmarchetti.com

PRODUZIONE MODULI ROTANTI



PAGINA HWC363-2-00

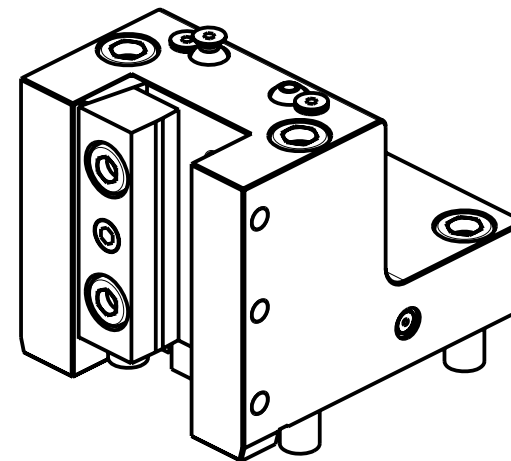
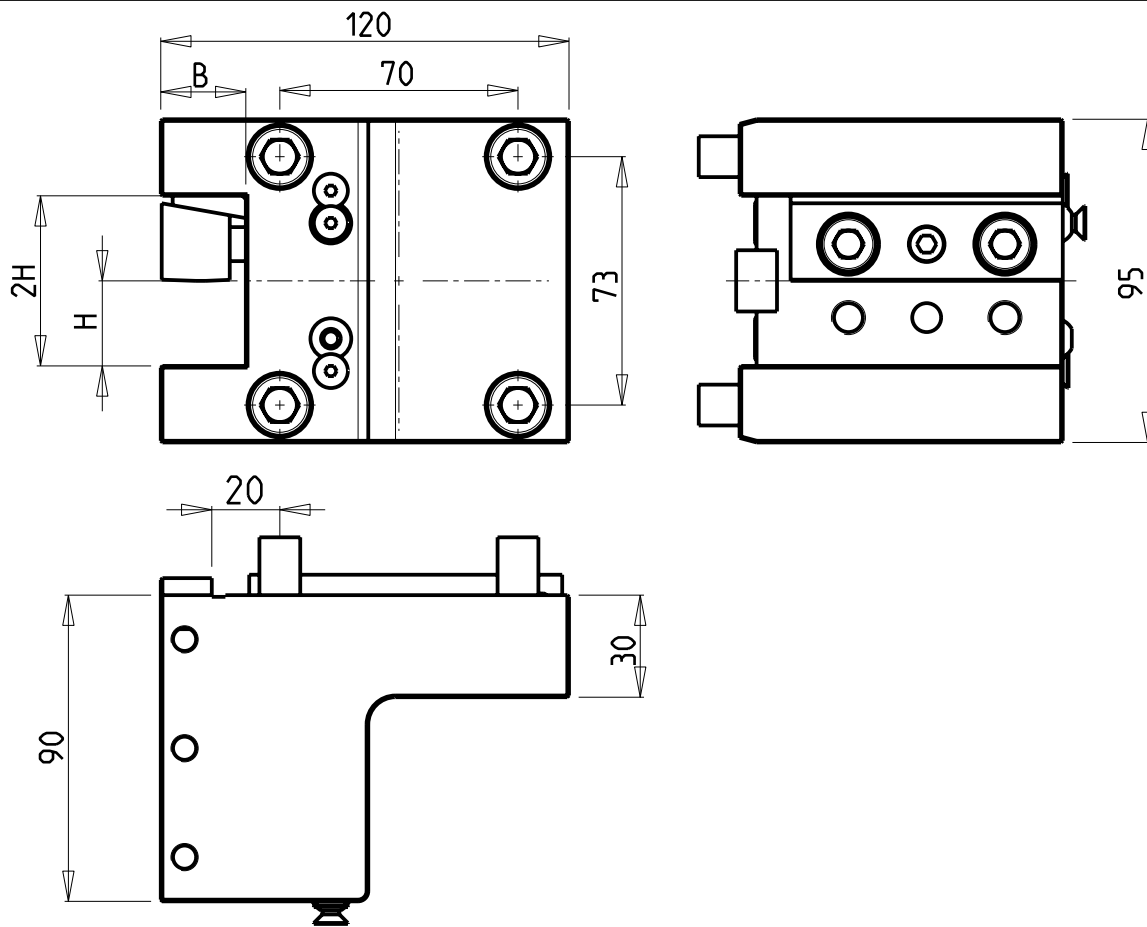

Cod. MT	N°Utensili N°Tools N°Werkzeuge	Reversibile lato mandrino/contromandrino Reversible sub/main spindle side Umkehrbare Spindel-seite/ Gegenspindel-seite	Misure Dimensions Masse	B	H	
DW00482500	1	X	mm	25	25	NEW
DW00482540	1	X	Inch	1"	1"	NEW

## HW ACHEON

HI-TECH 200 - HI-TECH 300/400 - HI-TECH 450 - VT450 - T2 - CUTEX 240

PORTAUTENSILE RADIALE SINGOLO

Radial single static tool

Radial Single-Werkzeughalter

**M.T. srl**

Via Casino Albini 480  
Tel. 0541/956034-957884  
Fax 0541/956341  
47842 S. GIOVANNI IN M. (RN)  
e-mail: mtma@mtmarchetti.com  
<http://www.mtmarchetti.com>

PRODUZIONE MODULI ROTANTI



PAGINA HWC423-2-00



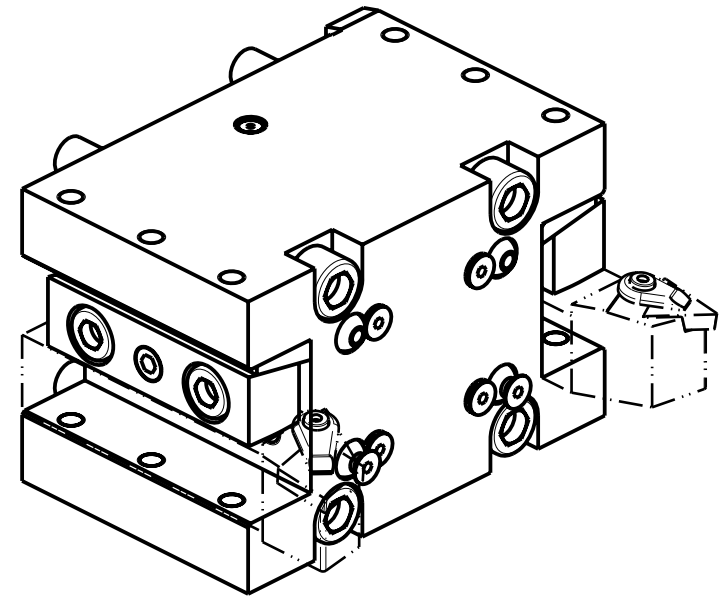
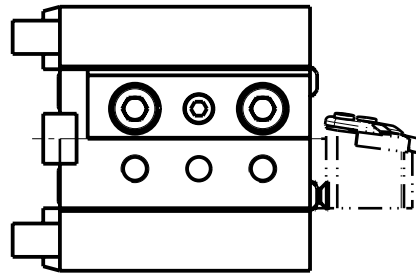
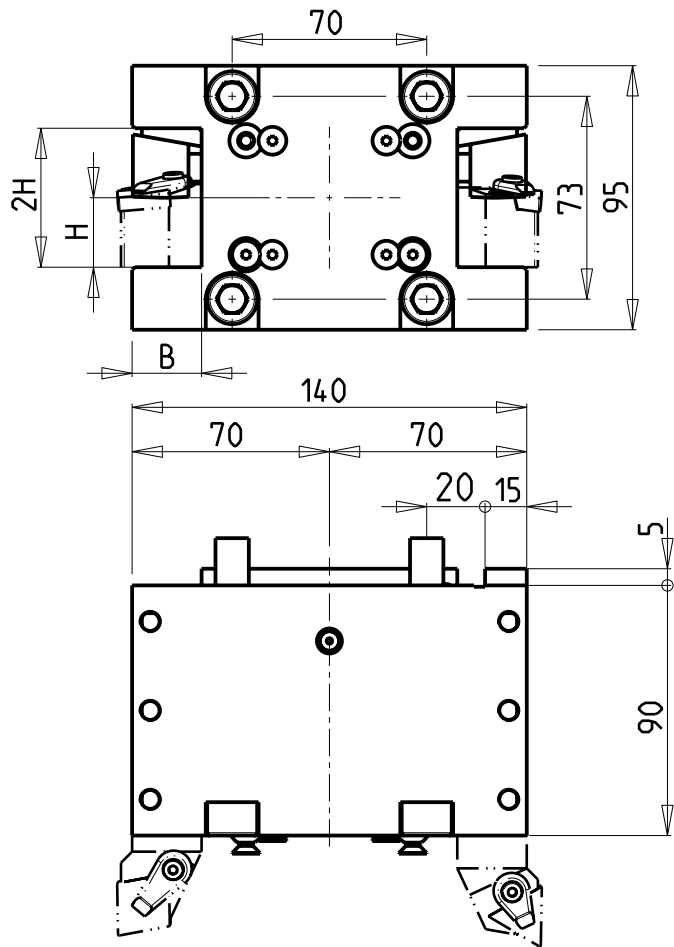

Cod. MT	N°Utensili N°Tools N°Werkzeuge	Reversibile lato mandrino/contromandrino Reversible sub/main spindle side Umkehrbare Spindel-seite/ Gegenspindel-seite	Misure Dimensions Masse	B	H	
DW00272500	2/4	X	mm	25	25	NEW
DW00272540	2/4	X	Inch	1"	1"	NEW

HW ACHEON

HI-TECH 200 - HI-TECH 300/400 - HI-TECH 450 - VT450 - T2 - CUTEX 240

PORTAUTENSILE RADIALE DOPPIO H=90mm

Radial double static tool H=90mm

Radial Doppel-Werkzeughalter H=90mm

**M.T. srl**

Via Casino Albini 480  
Tel. 0541/956034-957884  
Fax 0541/956341  
47842 S. GIOVANNI IN M. (RN)  
e-mail: mtma@mtmarchetti.com  
http://www.mtmarchetti.com

PRODUZIONE MODULI ROTANTI



PAGINA HWC453-2-00

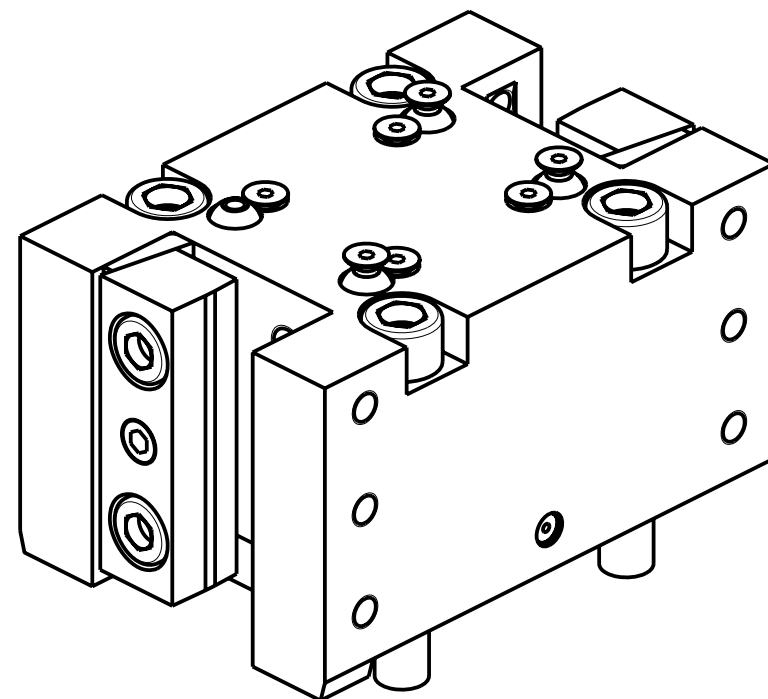
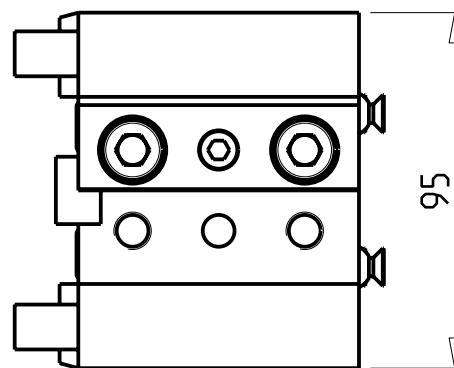
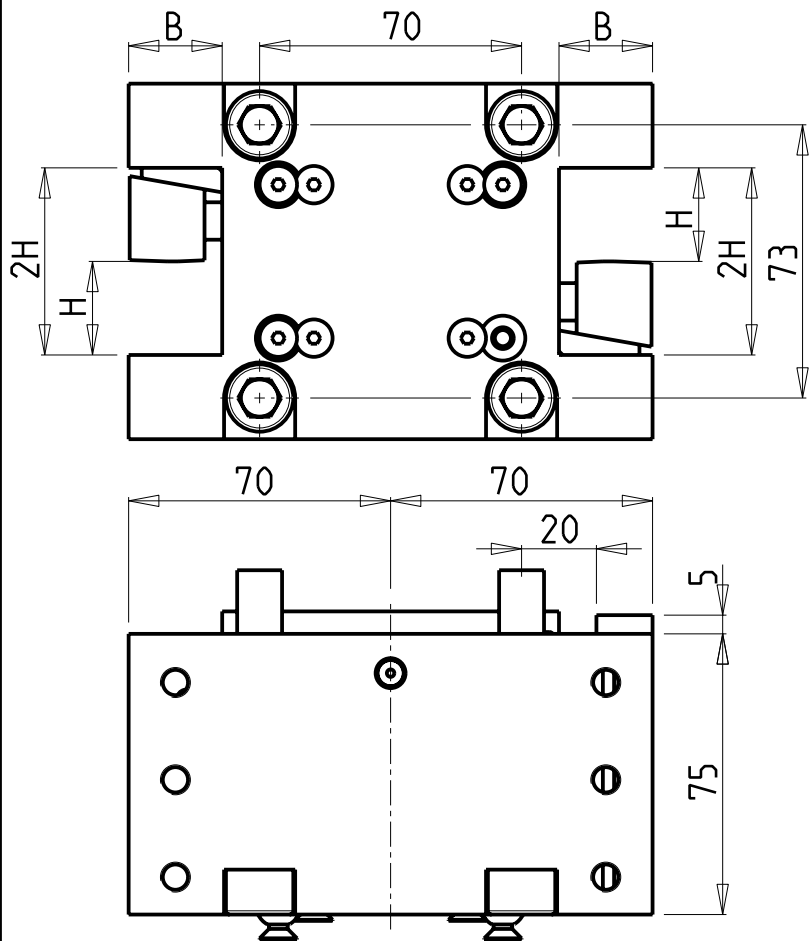

Cod. MT	N°Utensili N°Tools N°Werkzeuge	Reversibile lato mandrino/contromandrino Reversible sub/main spindle side Umkehrbare Spindelseite/ Gegenspindelseite	Misure Dimensions Masse	B	H	
DW 00672500	2/4	X	mm	25	25	NEW

HW ACHEON

HI-TECH 200 - HI-TECH 300/400 - HI-TECH 450 - VT450 - T2 - CUTEX 240

PORTAUTENSILE RADIALE DOPPIO H=75mm

Radial double static tool H=75mm

Radial Doppel-Werkzeughalter H=75mm

**M.T. srl**

Via Casino Albini 480  
Tel. 0541/956034-957884  
Fax 0541/956341  
47842 S. GIOVANNI IN M. (RN)  
e-mail: mtma@mtmarchetti.com  
http://www.mtmarchetti.com

PRODUZIONE MODULI ROTANTI



PAGINA HWC453-2-10

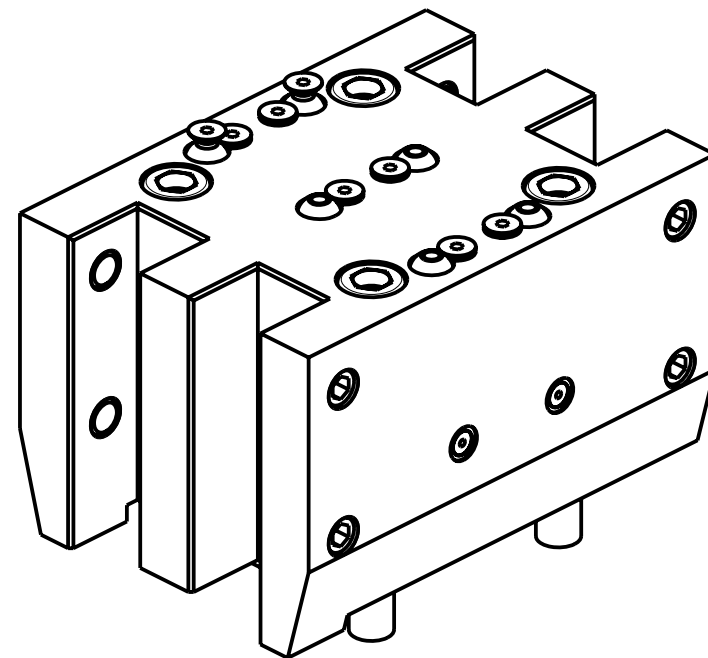
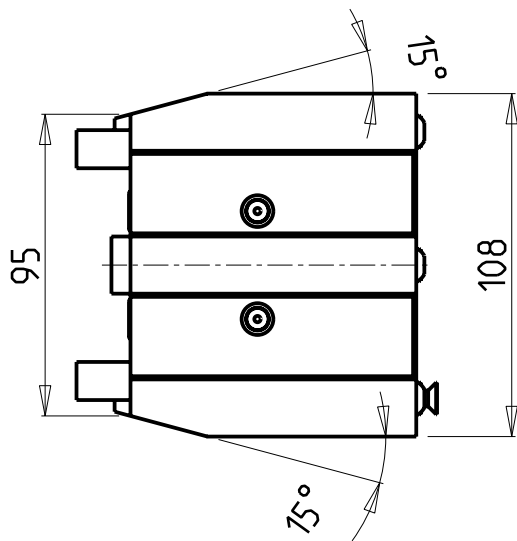
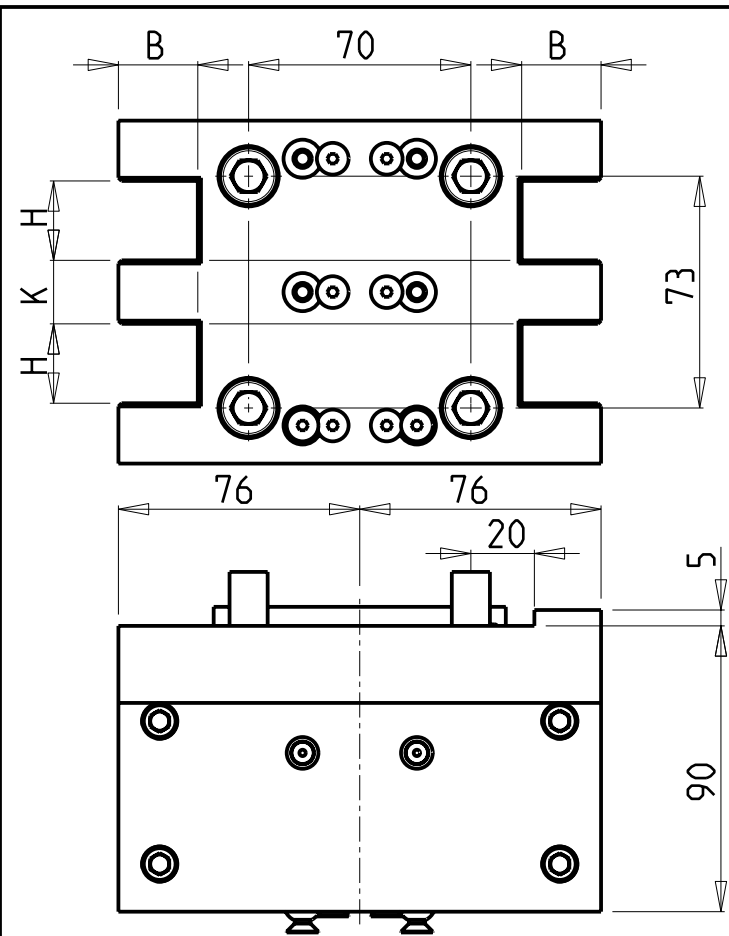

Cod. MT	N°Utensili N°Tools N°Werkzeuge	Reversibile lato mandrino/contromandrino Reversible sub/main spindle side Umkehrbare Spindel-seite/ Gegenspindel-seite	Misure Dimensions Masse	H	K	B	
DW 00622500	4	X	mm	25	20	25	NEW
DW 00622540	4	X	inch	1"	3/4"	1"	NEW

HW ACHEON  
HI-TECH 450 - T2

PORTAUTENSILE RADIALE DOPPIO SOVRAPPOSTO  
Radial double side twin static tool  
Radial Doppel-Werkzeughalter ueberlagert

**M.T. srl**

Via Casino Albini 480  
Tel. 0541/956034-957884  
Fax 0541/956341  
47842 S. GIOVANNI IN M. (RN)  
e-mail: mtma@mtmarchetti.com  
http://www.mtmarchetti.com

PRODUZIONE MODULI ROTANTI



PAGINA HWC463-2-00

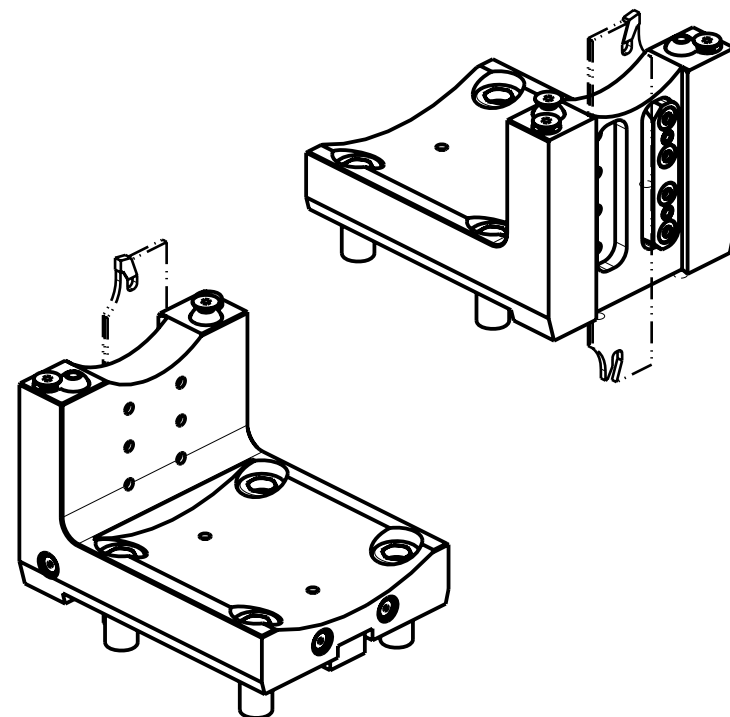
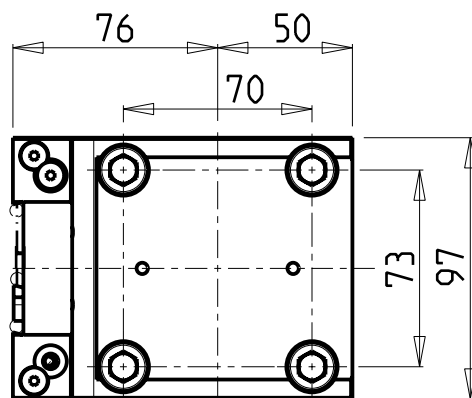
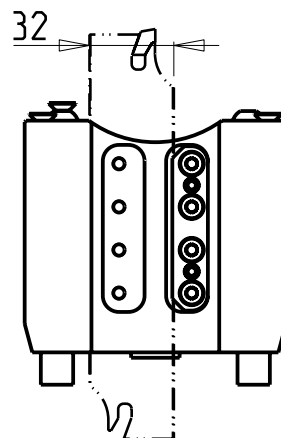
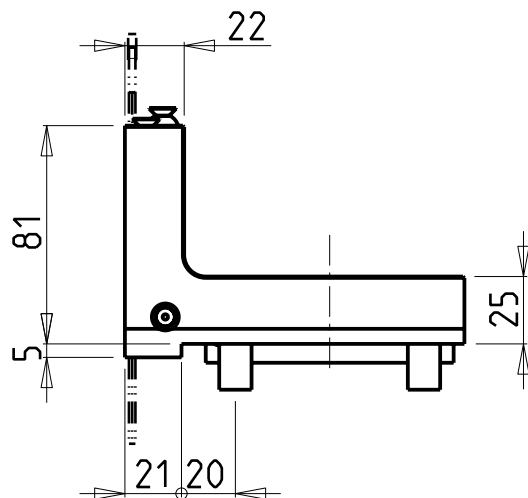
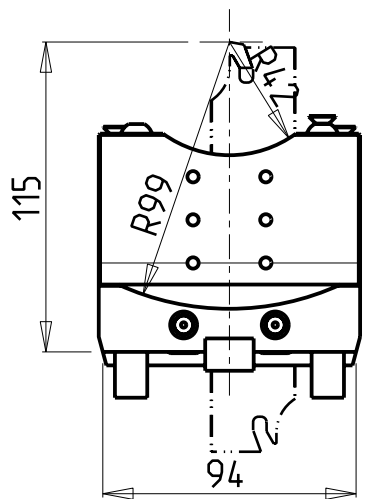

POSSIBILITA' DI LAVORO M3/M4  
 OPTION OF M3/M4 WORKING  
 ARBEITSMOEGlichkeit M3/M4

**DOTAZIONI - SUPPLIED WITH - AUSSTATTUNG**

N°1 - LAMA - BLADE - KLINGE ISCAR H=32 Sp. 3/4mm  
 (KENNAMETAL OPTIONAL)

N°10 - INSERTI - INSERTS - EINLAGEN

N°1 - CHIAVE A T PER MONTAGGIO INSERTI  
 - T-WRENCH FOR INSERT SET UP  
 - T-SCHLUESSEL FUER EINSATZSTUECK-MONTAGE

Cod. MT	N°Utensili N°Tools N°Werkzeuge	Reversibile lato mandrino/contromandrino Reversible sub/main spindle side Umkehrbare Spindel-seite/ Gegenspindel-seite	Lubr.esterna Ext. coolant Aussenkuehlung
DW 00690132	1	X	X

NEW

HW ACHEON

HI-TECH 200 - HI-TECH 300/400 - HI-TECH 450 - VT450 - T2 - CUTEX 240

PORTAUTENSILE RADIALE PER LAMA

Radial blade holder

Radial Abstechhalter

**M.T. srl**

Via Casino Albini 480  
 Tel. 0541/956034-957884  
 Fax 0541/956341  
 47842 S. GIOVANNI IN M. (RN)  
 e-mail: mtma@mtmarchetti.com  
 http://www.mtmarchetti.com

PRODUZIONE MODULI ROTANTI



PAGINA HW C510-2-00

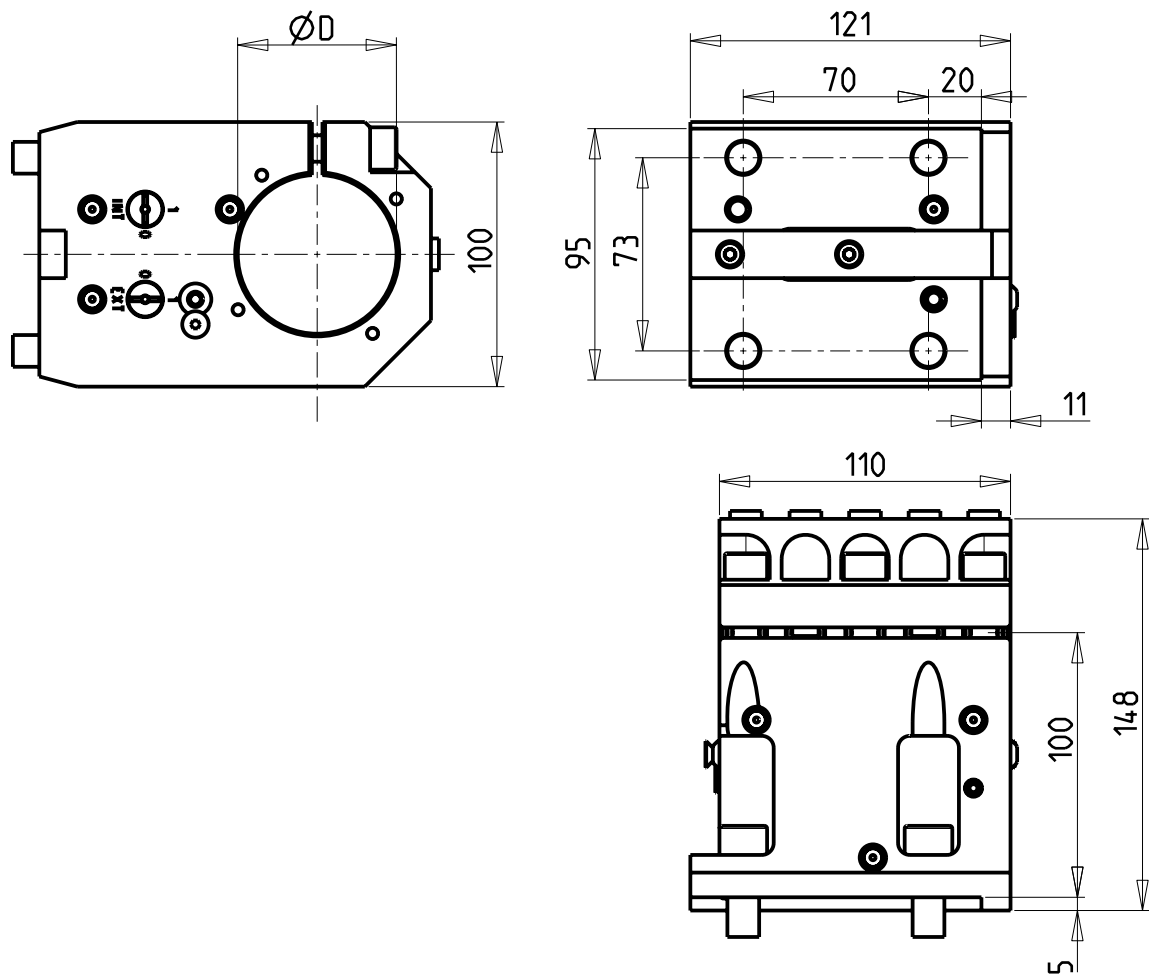

KIT ADDUZIONE INTERNA (OPZIONALE)  
 KIT FOR INTERNAL COOLANT (OPTIONAL)  
 KIT FUR INTERNE KUEHLMITTELZUFUHR (OPTIONAL)  
 Ø60 cod. KIT1003025

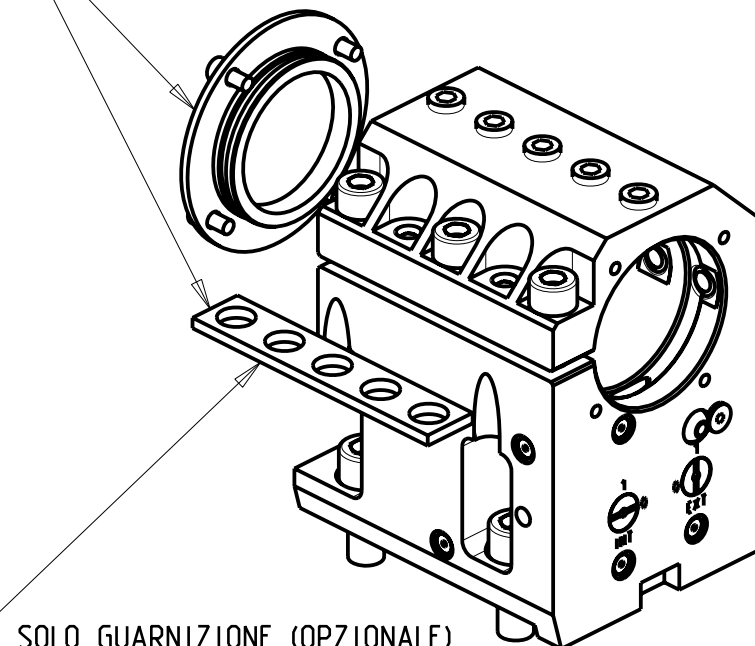

SOLO GUARNIZIONE (OPZIONALE)  
 ONLY SEAL (OPTIONAL) NUR  
 DICHTUNG (OPTIONAL) cod.  
 0520013

PER BOCCOLE DI RIDUZIONE VEDI PAG. TBL150-1-00  
 FOR REDUCING BUSHINGS SEE PAGE TBL150-1-00  
 FUR REDUZIERBUCHSE SIEHE SEITE TBL150-1-00

Cod. MT	N°Utensili N°Tools N°Werkzeuge	Reversibile lato mandrino/contromandrino Reversible sub/main spindle side Umkehrbare Spindel-seite/ Gegenspindel-seite	Lubrificazione int. opzionale Coolant through optional Innenkuehlung Optional	Lubrificazione est. Ext. coolant Aussenkuehlung	Misure Dimensions Masse	D
DW00746000	1	X	X	X	mm	60

NEW

HW ACHEON

HI-TECH 300/400 - HI-TECH 450 - VT450 - T2 - CUTEX 240

PORTAUTENSILE ASSIALE PER BARENO Ø60mm H=100mm

Axial single boring bar holder Ø60mm H=100mm

Axial Bohrhalter Ø60mm H=100mm

**M.T. srl**

Via Casino Albini 480  
 Tel. 0541/956034-957884  
 Fax 0541/956341

47842 S. GIOVANNI IN M. (RN)  
 e-mail: mtma@mtmarchetti.com  
 http://www.mtmarchetti.com

PRODUZIONE MODULI ROTANTI



PAGINA HWC590-2-20

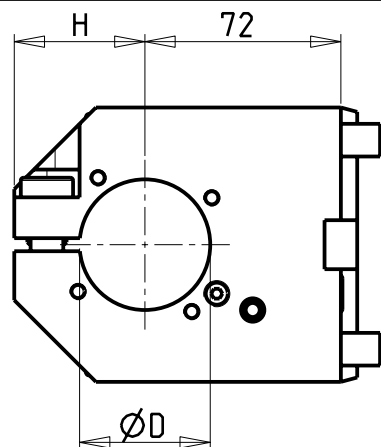
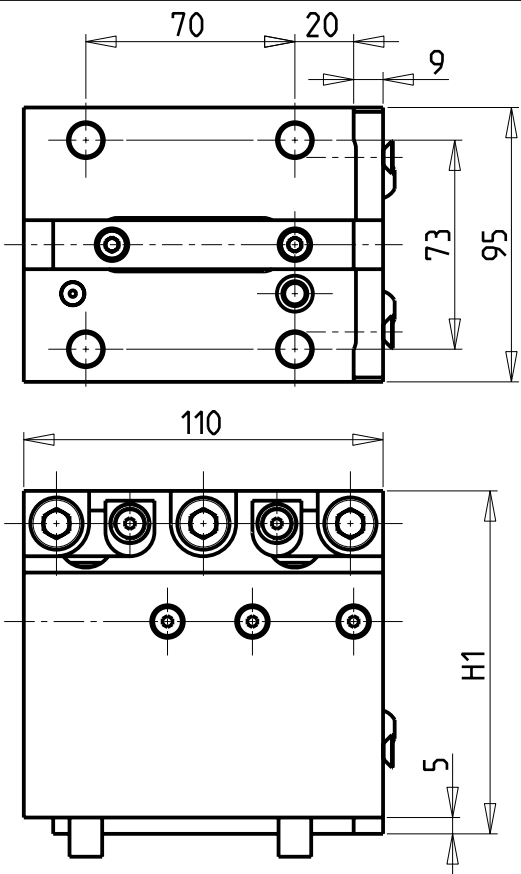

KIT ADDUZIONE INTERNA (OPZIONALE)  
 KIT FOR INTERNAL COOLANT (OPTIONAL)  
 KIT FUER INTERNE KUEHLMITTELZUFUHR (OPTIONAL)  
 Ø1 1/2" cod. KIT1003004  
 Ø40 cod. KIT1003003  
 Ø50-Ø2" cod. KIT1003002

SOLO GUARNIZIONE (OPZIONALE)  
 ONLY SEAL (OPTIONAL)  
 NUR DICHTUNG (OPTIONAL)  
 cod. 0520013

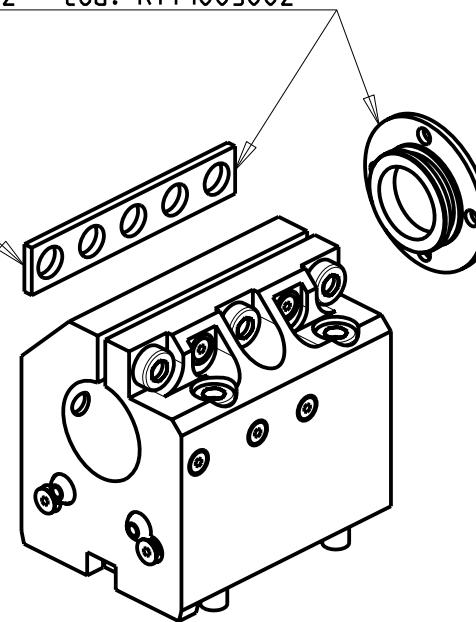

PER BOCCOLE DI RIDUZIONE VEDI PAG. TBL150-1-00  
 FOR REDUCING BUSHINGS SEE PAGE TBL150-1-00  
 FÜR REDUZIERBUCHSE SIEHE SEITE TBL150-1-00

Cod. MT	N°Utensili N°Tools N°Werkzeuge	Reversibile lato mandrino/contromandrino Reversible sub/main spindle side Umkehrbare Spindel-seite/ Gegenspindel-seite	Lubrificazione int. opzionale Coolant through optional Innenkuehlung Optional	Lubrificazione est. Ext. coolant AusSENkuehlung	Misure Dimensions Masse	D	H	H1	
0834000	1	X	X	X	mm	40	40	117.5	NEW
0833810	1	X	X	X	Inch	1 1/2"	40	117.5	NEW
0835000	1	X	X	X	mm	50	46.5	123.5	NEW
0835080	1	X	X	X	Inch	2"	46.5	123.5	NEW

HW ACHEON

HI-TECH 200 - HI-TECH 300/400 - HI-TECH 450 - VT450 - CUTEX 240

PORTAUTENSILE ASSIALE PER BARENO Ø40mm/Ø1 1/2"/Ø50mm/Ø2" H=72mm

Axial single boring bar holder Ø40mm/Ø1 1/2"/Ø50mm/Ø2" H=72mm

Axial Bohrhälter Ø40mm/Ø1 1/2"/Ø50mm/Ø2" H=72mm

**M.T. srl**

Via Casino Albini 480  
 Tel. 0541/956034-957884  
 Fax 0541/956341  
 47842 S. GIOVANNI IN M. (RN)  
 e-mail: mtma@mtmarchetti.com  
 http://www.mtmarchetti.com

PRODUZIONE MODULI ROTANTI



PAGINA HW C 610-2-20

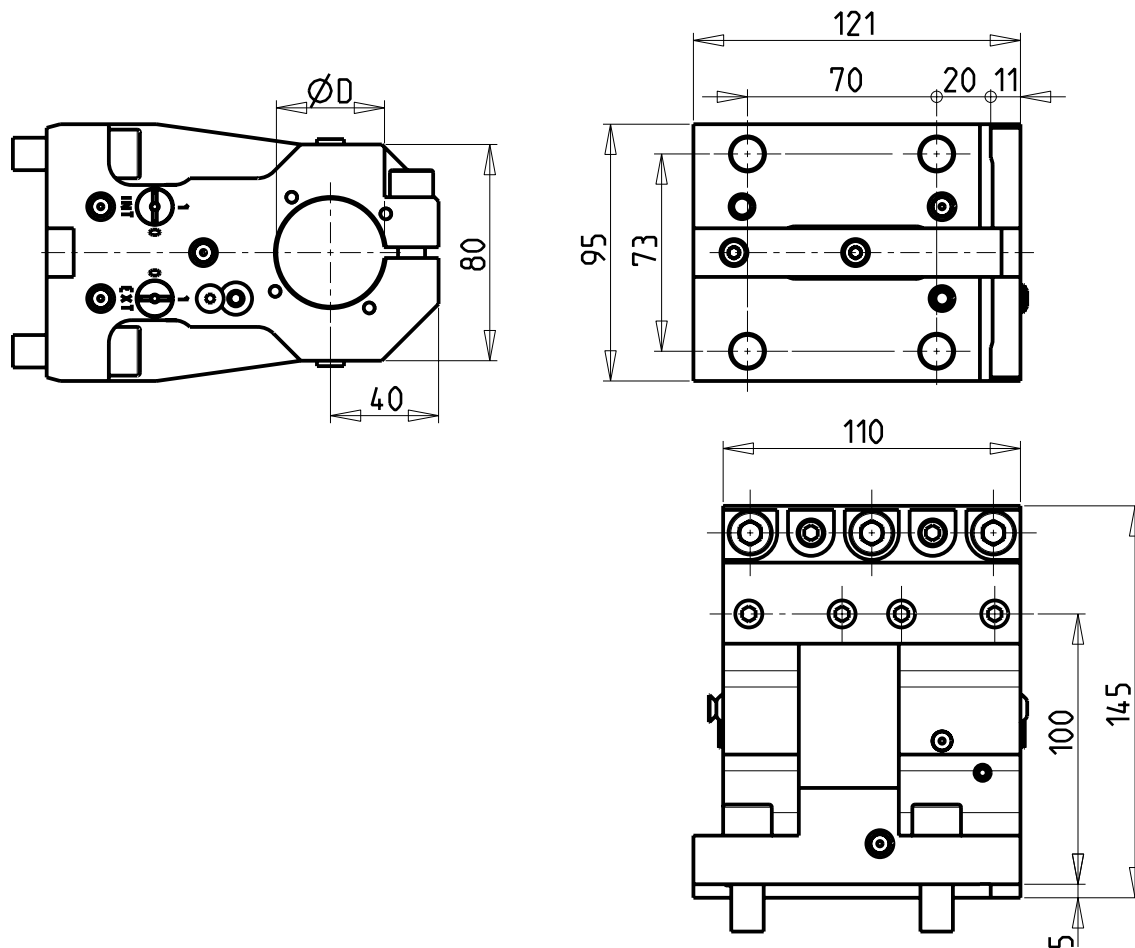

KIT ADDUZIONE INTERNA (OPZIONALE)  
 KIT FOR INTERNAL COOLANT (OPTIONAL)  
 KIT FÜR INTERNE KUEHLMITTELZUFUHR (OPTIONAL)  
 Ø40 cod. KIT1003003

SOLO GUARNIZIONE (OPZIONALE)  
 ONLY SEAL (OPTIONAL)  
 NUR DICHTUNG (OPTIONAL)  
 cod. 0520013

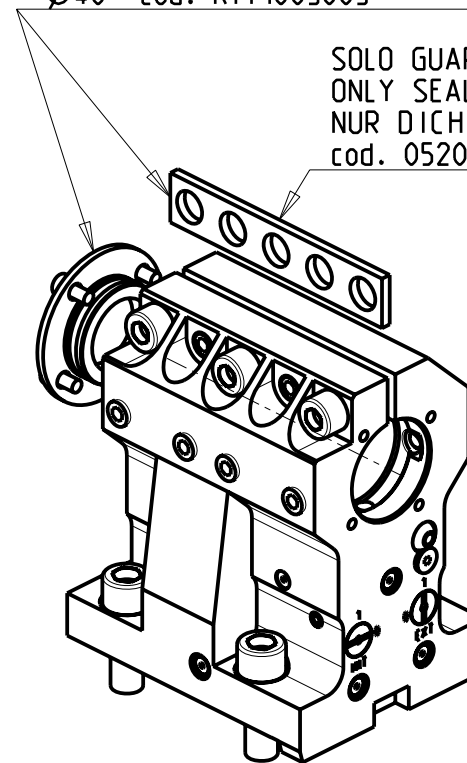

PER BOCCOLE DI RIDUZIONE VEDI PAG. TBL150-1-00  
 FOR REDUCING BUSHINGS SEE PAGE TBL150-1-00  
 FÜR REDUZIERBUCHSE SIEHE SEITE TBL150-1-00

Cod. MT	N°Utensili N°Tools N°Werkzeuge	Reversibile lato mandrino/contromandrino Reversible sub/main spindle side Umkehrbare Spindel-seite/ Gegenspindel-seite	Lubrificazione int. opzionale Coolant through optional Innenkuehlung Optional	Lubrificazione est. Ext. coolant Aussenkuehlung	Misure Dimensions Masse	D
DW00204000	1	X	X	X	mm	40

NEW

HW ACHEON

HI-TECH 300/400 - HI-TECH 450 - VT450 - T2

PORTAUTENSILE ASSIALE PER BARENO Ø40mm H=100mm

Axial single boring bar holder Ø40mm H=100mm

Axial Bohrhalter Ø40mm H=100mm

**M.T. srl**

Via Casino Albini 480  
 Tel. 0541/956034-957884  
 Fax 0541/956341  
 47842 S. GIOVANNI IN M. (RN)  
 e-mail: mtma@mtmarchetti.com  
 http://www.mtmarchetti.com

PRODUZIONE MODULI ROTANTI



PAGINA HWC640-2-20

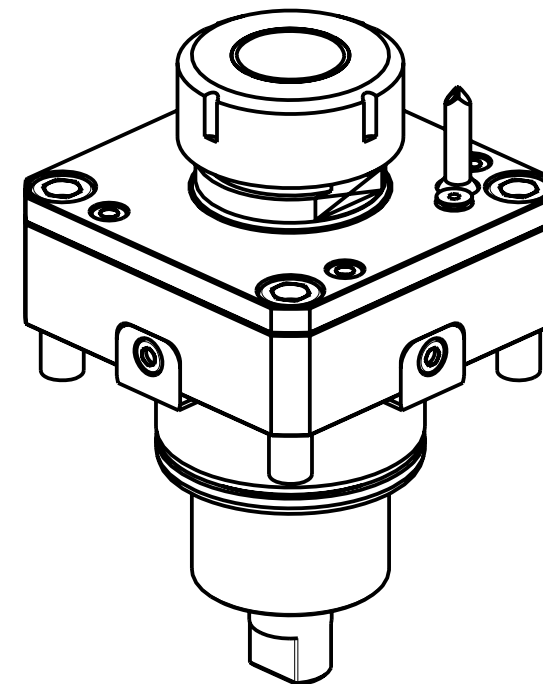
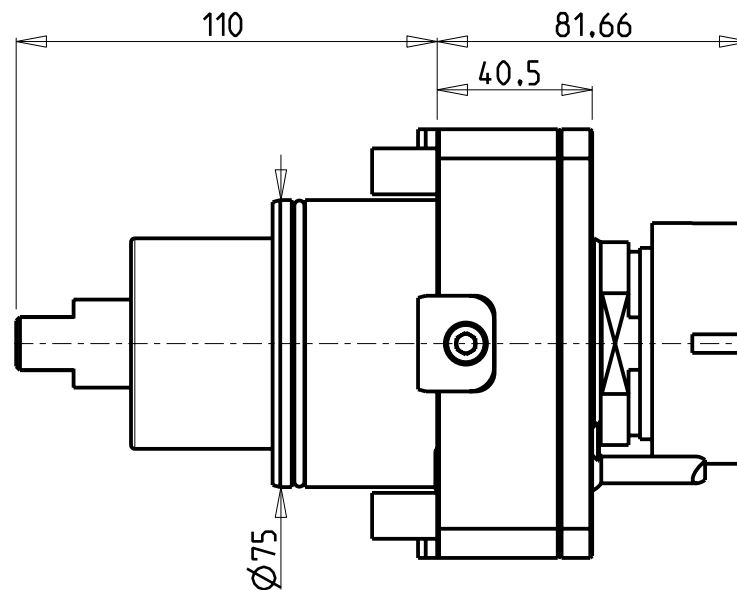
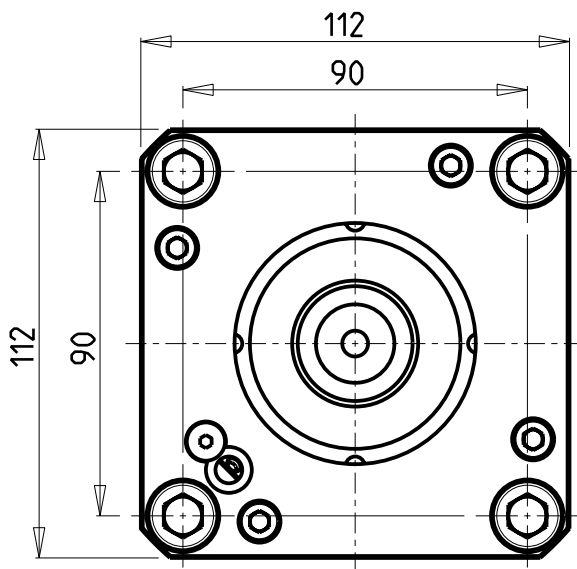

Cod. MT	Cod. EPPINGER	Mandrino Spindle Spindel	I	RPM	Coppia Max Max Torque Max Drehmoment	Lubrificazione int. Coolant through Innenkuehlung	Lubrificazione est. Ext. coolant Aussekuehlung	CHIAVI NON INCLUDE Keys not included Schluessel nicht einbegriffen		
								CHSTER40	CHUB46 o 0290018	
0291540	R78606	ER40	1:1	6000	100Nm		X	CHSTER40	CHUB46 o 0290018	NEW
0291040	-	ER40	1:1	6000	100Nm	P=30bar		CHSTER40	CHUB46 o 0290018	NEW

HW ACHEON

HI-TECH 550

MODULO MOTORIZZATO RADIALE

Radial driven tool

Radial angetriebenes Werkzeug

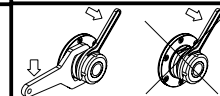
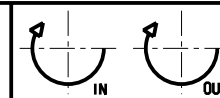

**M.T. srl**

Via Casino Albini 480  
Tel. 0541/956034-957884  
Fax 0541/956341

47842 S. GIOVANNI IN M. (RN)  
e-mail: mtma@mtmarchetti.com  
http://www.mtmarchetti.com

PRODUZIONE MODULI ROTANTI



PAGINA HW C010-3-00



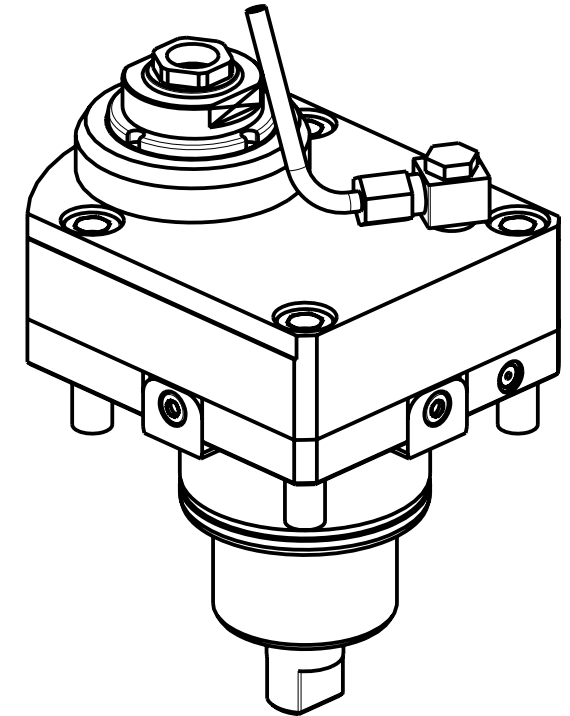
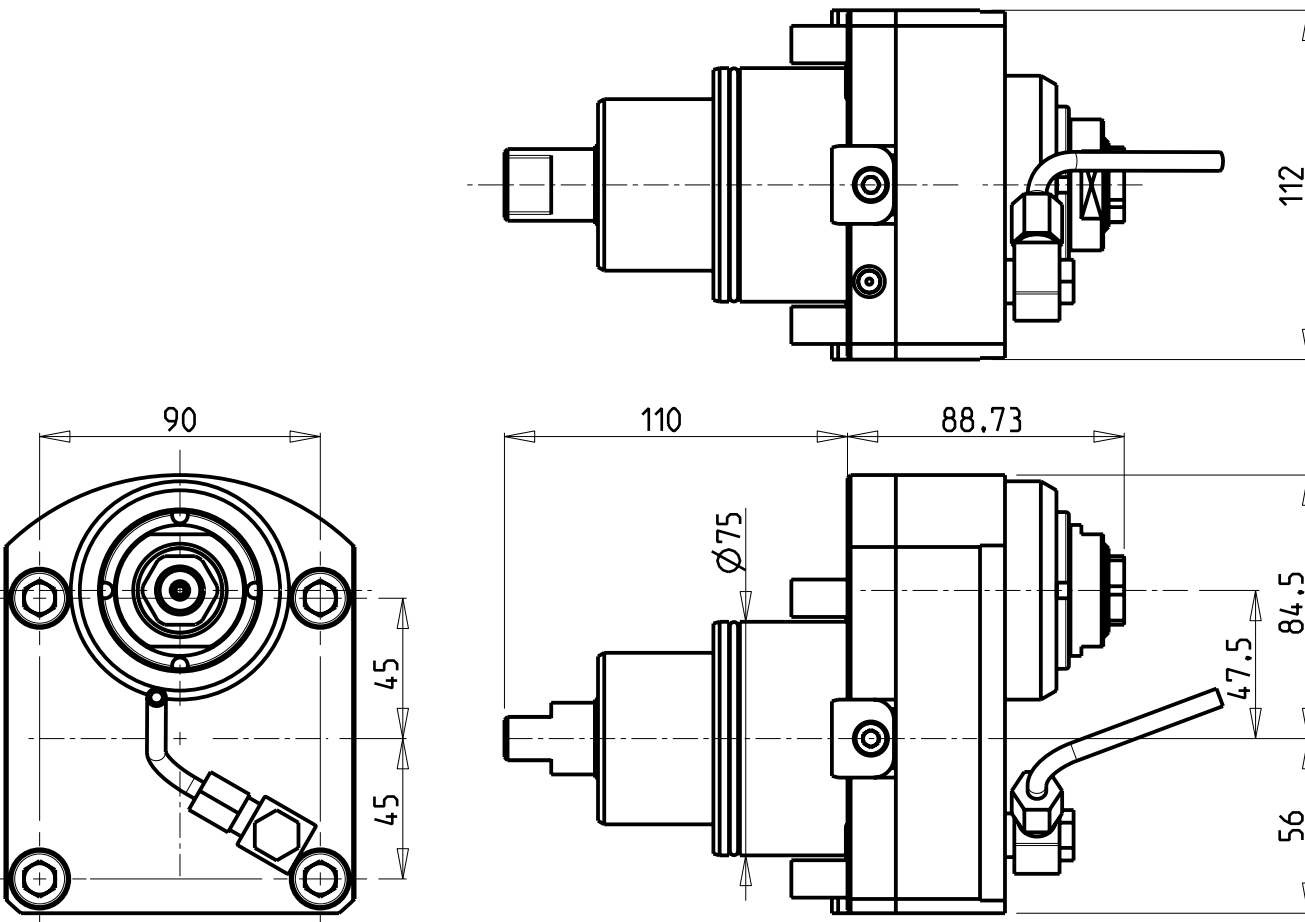

Cod. MT	Mandrino Spindle Spindel	I	RPM	Coppia Max Max Torque Max Drehmoment	Reversibile lato mandrino/controlmandrino Reversible sub/main spindle side Umkehrbare Spindelseite/ Gegenspindelseite	Lubr. esterna Ext. coolant Aussenkuehlung	CHIAVI NON INCLUSE Keys not included Schluessel nicht einbegriffen
DW00430120	ERA20	1:1	6000	80Nm	X	X	CHUB36 CHUB22 NEW

HW ACHEON  
HI-TECH 550

MODULO MOTORIZZATO RADIALE DISASSATO IN Z 47.5mm  
Radial driven tool re-directed in Z by 47.5mm  
Radial angetriebenes Werkzeug achsversetzt in Z um 47.5mm

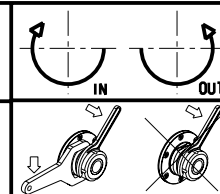

**M.T. srl**  
Via Casino Albini 480  
Tel. 0541/956034-957884  
Fax 0541/956341  
47842 S. GIOVANNI IN M. (RN)  
e-mail: mtma@mtmarchetti.com  
http://www.mtmarchetti.com

PRODUZIONE MODULI ROTANTI



PAGINA HWC033-3-10

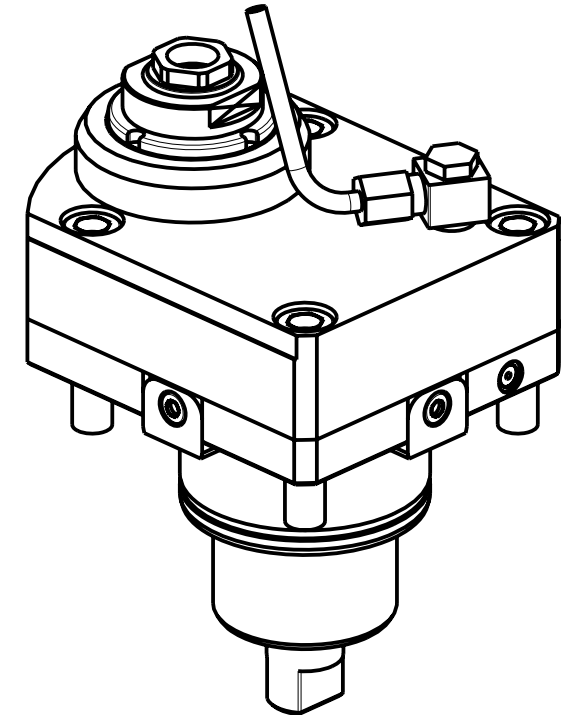
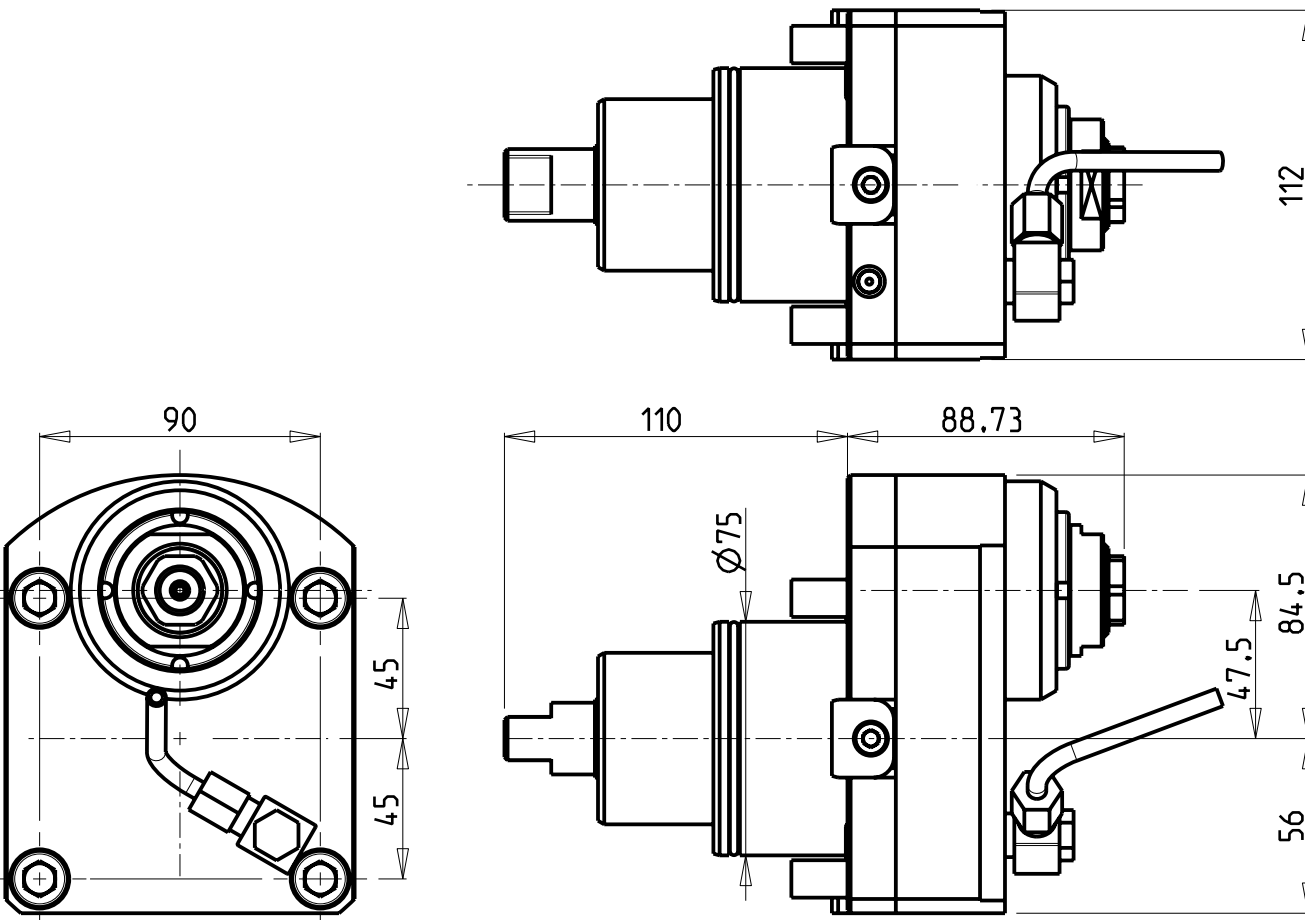

Cod. MT	Mandrino Spindle Spindel	I	RPM	Coppia Max Max Torque Max Drehmoment	Reversibile lato mandrino/controlmandrino Reversible sub/main spindle side Umkehrbare Spindelseite/ Gegenspindelseite	Lubr. esterna Ext. coolant Aussenkuehlung	CHUB36	CHUB22	NEW
DW00430220	ERA20	1:2	12000	50Nm	X	X			

HW ACHEON

HI-TECH 550

MODULO MOTOR. RADIALE MOLTIPLICATO I=1:2 DISASSATO IN Z 47.5mm

Radial geared-up I=1:2 driven tool re-directed in Z by 47.5mm

Radial angetriebenes Werkzeug uebersetzt I=1:2 achsversetzt in Z um 47.5mm

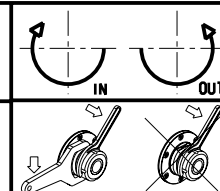

**M.T. srl**

Via Casino Albini 480  
Tel. 0541/956034-957884

Fax 0541/956341

47842 S. GIOVANNI IN M. (RN)

e-mail: mtma@mtmarchetti.com

http://www.mtmarchetti.com

PRODUZIONE MODULI ROTANTI



PAGINA HW C033-3-30

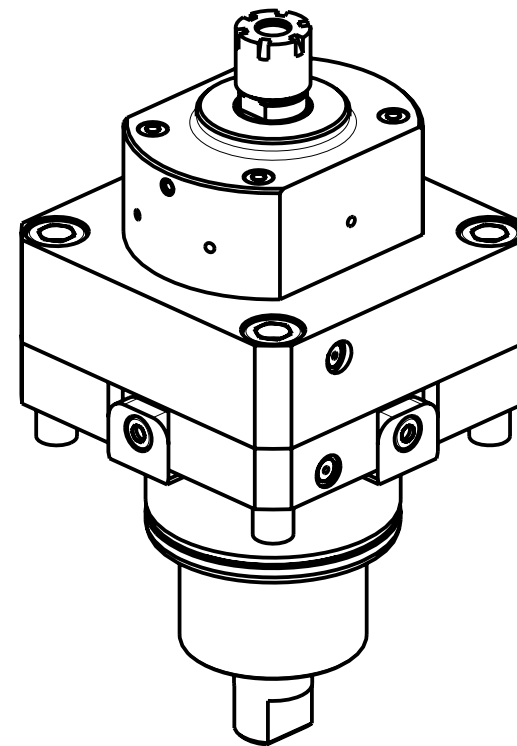
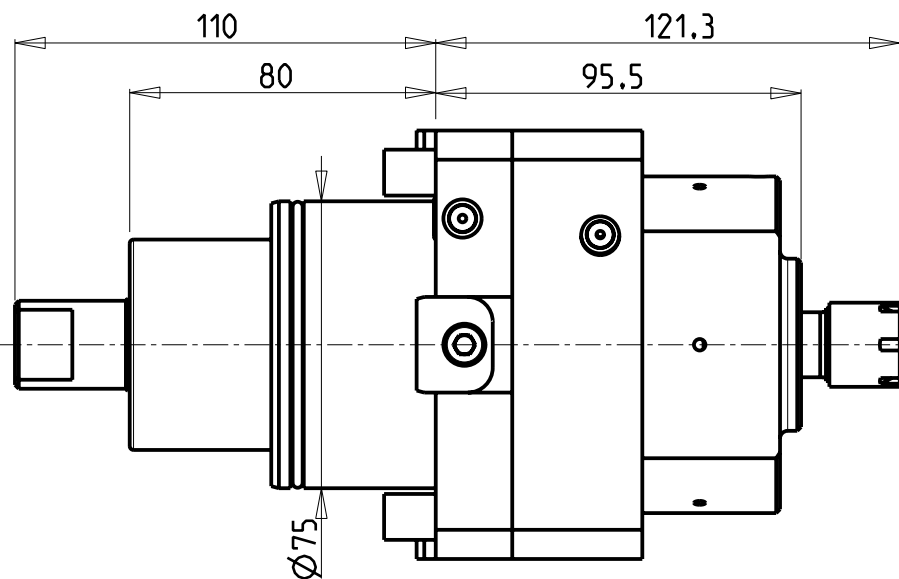
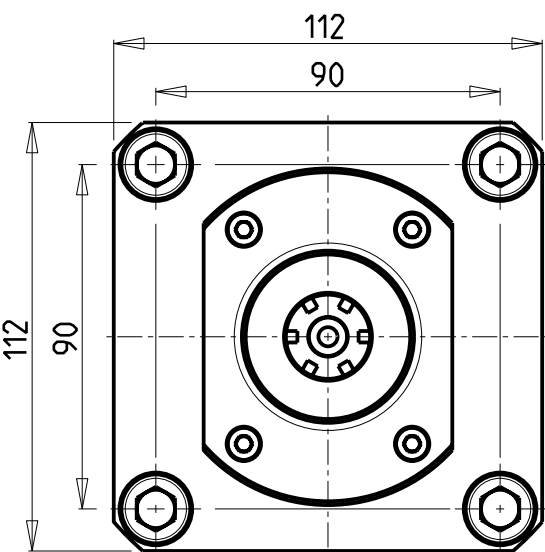

**ATTENZIONE - ATTENTION - ACHTUNG**

- PRIMA DI UTILIZZARE IL MOTORIZZATO CONSULTARE LE ISTRUZIONI ALLEGATE!
- BEFORE USING THE DRIVEN TOOL, PLEASE CHECK THE ENCLOSED INSTRUCTION SHEET!
- VOR DER BENUTZUNG DES ANGETRIEBENEN WERKZEUGES, DIE BEILIEGENDEN INSTRUKTIONEN DURCHLESEN!

**ATTENZIONE - ATTENTION - ACHTUNG**

- Per lo smontaggio degli utensili utilizzare sempre la chiave di contrasto come indicato nel manuale d'uso.
- For disassembly of the tools use always the contrast key as mentioned in the user instructions.
- Fuer das Abmontieren der Werkzeuge immer den Gegenschlüssel benutzen wie in der Bedienungsanleitung erwäehnt.

Cod. MT	Mandrino Spindle Spindel	I	RPM	Coppia Max Max Torque Max Drehmoment	Lubrificazione int. Coolant through Innenkuehlung	CHIAVI INCLUSE Keys included Schluessel einbegriffen	
DW00450116	ER16	1:4	12000	15Nm	P=30bar	CHMNER16	CHUB17

NEW

HW ACHEON

HI-TECH 550

MODULO MOTORIZZATO RADIALE MOLTIPLICATO I=1:4

Radial geared-up I=1:4 driven tool

Radial angetriebenes Werkzeug uebersetzt I=1:4

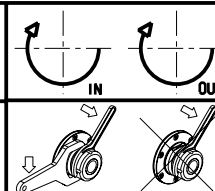

**M.T. srl**

Via Casino Albini 480  
Tel. 0541/956034-957884  
Fax 0541/956341

47842 S. GIOVANNI IN M. (RN)  
e-mail: mtma@mtmarchetti.com  
http://www.mtmarchetti.com

PRODUZIONE MODULI ROTANTI



PAGINA HWC058-3-00

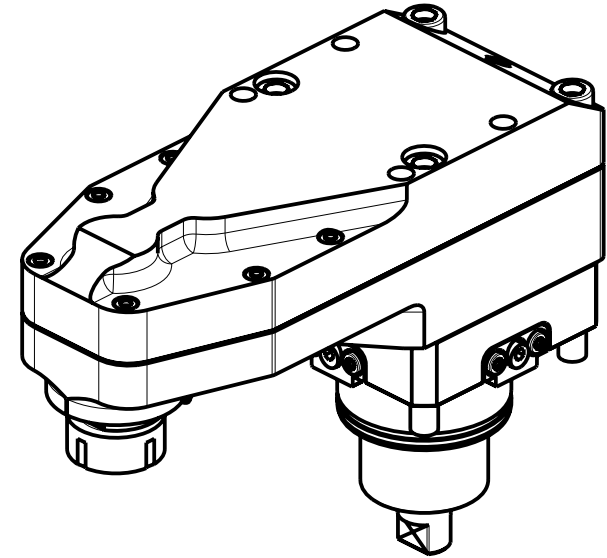
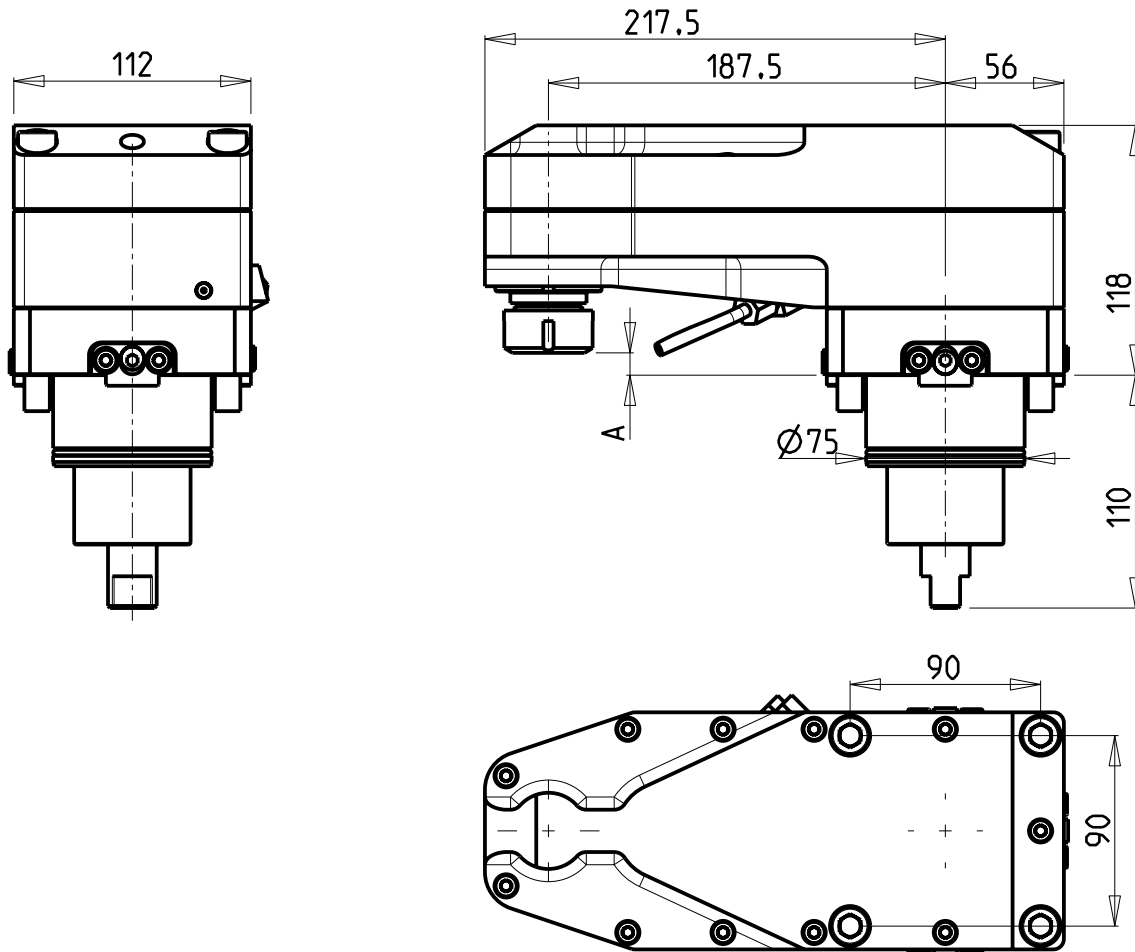

Cod. MT	Mandrino Spindle Spindel	I	RPM MAX	Coppia Max Max Torque Max Drehmoment	Lubrificazione est. Ext. coolant Ausseinkuehlung	A	CHIAVI NON INCLUSE Keys not included Schlüssel nicht einbegriffen		
0841225	ER25	1:2	8000	40Nm	X	8.84	CHSTER25	CHUB36	NEW
0841232	ER32	1:2	8000	40Nm	X	3.66	CHSTER32	CHUB36	NEW

HW ACHEON  
HI-TECH 550

MODULO MOTORIZZATO RADIALE ROVESCiato DISASSATO IN Z 187.5mm  
Radial inverted driven tool re-directed in Z by 187.5 mm  
Radial angetriebenes Werkzeug ungekehrt achsversetzt in Z um 187.5 mm

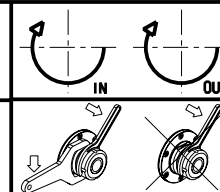

**M.T. srl**  
Via Casino Albini 480  
Tel. 0541/956034-957884  
Fax 0541/956341  
47842 S. GIOVANNI IN M. (RN)  
e-mail: mtma@mtmarchetti.com  
http://www.mtmarchetti.com

PRODUZIONE MODULI ROTANTI  
  
PAGINA HW C120-3-10

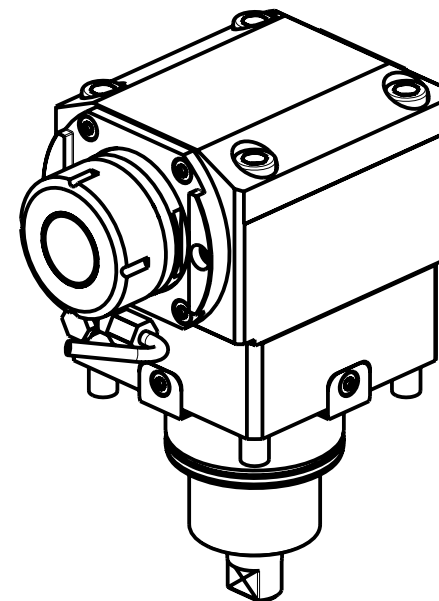
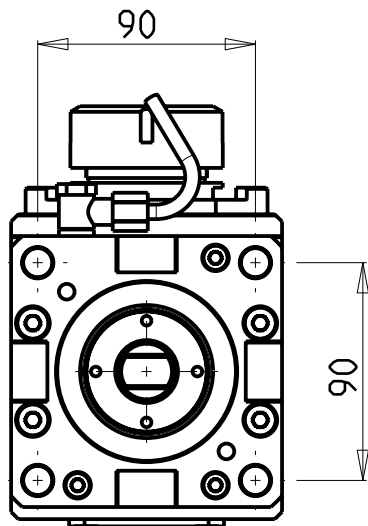
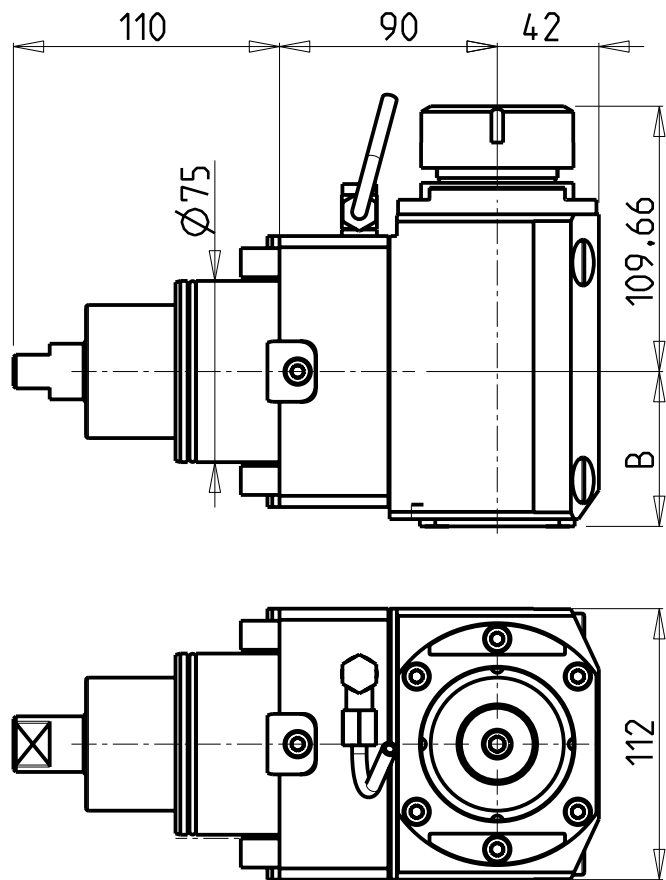

### CUSCINETTI MAGGIORATI PER LAVORAZIONI PESANTI

Reinforced bearings for  
heavy machining

Vergroesserte Lager fuer  
schwerere Bearbeitungen

Cod. MT	Mandrino Spindle Spindel	I	RPM	Coppia Max Max Torque Max Drehmoment	Lubrificazione int. Coolant through Innenkuehlung	Lubrificazione est. Ext. coolant Aussenkuehlung	B	CHIAVI NON INCLUSE Keys not included Schlüssel nicht einbegriffen		
								CHSTER40	OKU0430007	
DW00650140	ER40	1:1	6000	100Nm		X	64	CHSTER40	OKU0430007	NEW
DW00650240	ER40	1:1	6000	100Nm	P=70bar	X	77.5	CHSTER40	OKU0430007	NEW

- Chiave inclusa
- Key included
- Schlüssel inbegriffen

HW ACHEON

HI-TECH 550

MODULO MOTORIZZATO ASSIALE MAGGIORATO H=90mm

Axial reinforced driven tool H=90mm

Axial angetriebenes Werkzeug vergroessert H=90mm

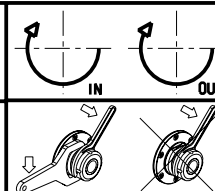

**M.T. srl**

Via Casino Albini 480  
Tel. 0541/956034-957884  
Fax 0541/956341

47842 S. GIOVANNI IN M. (RN)  
e-mail: mtma@mtmarchetti.com  
http://www.mtmarchetti.com

PRODUZIONE MODULI ROTANTI



PAGINA HW C 170-3-20

**ATTENZIONE - ATTENTION - ACHTUNG**

- Per lo smontaggio degli utensili utilizzare sempre la chiave di contrasto come indicato nel manuale d'uso.
- For disassembly of the tools use always the contrast key as mentioned in the user instructions.
- Fuer das Abmontieren der Werkzeuge immer den Gegenschlüssel benutzen wie in der Bedienungsanleitung erwäehnt.

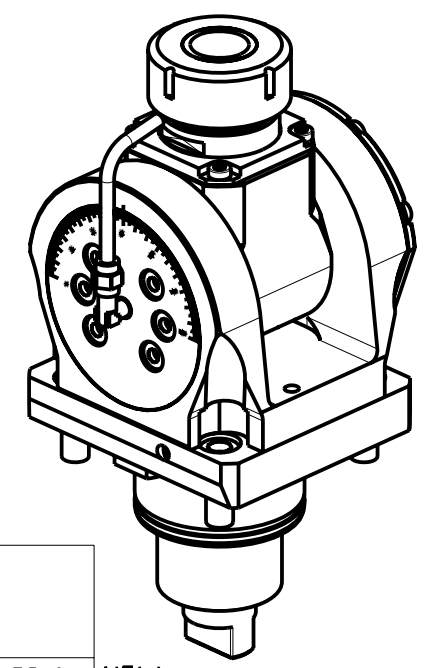
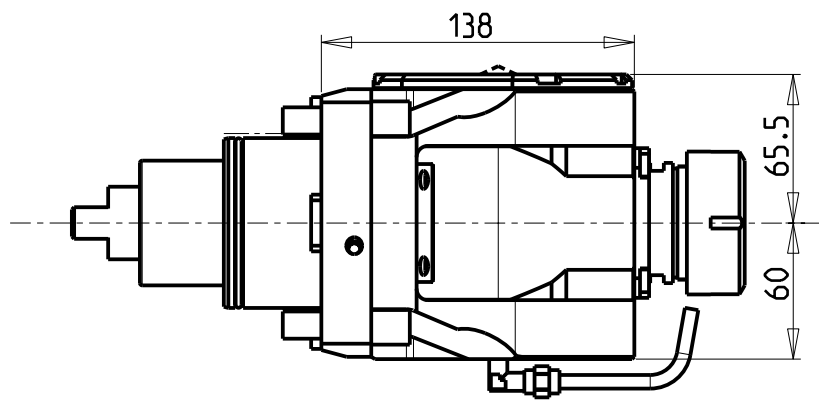
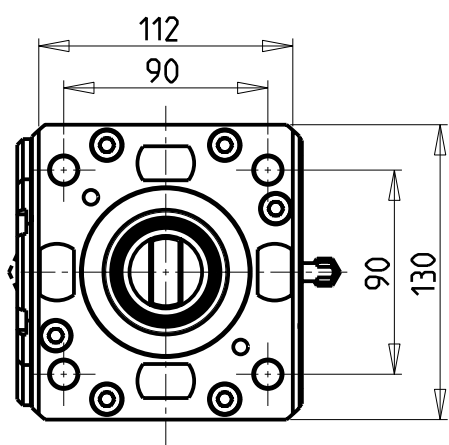
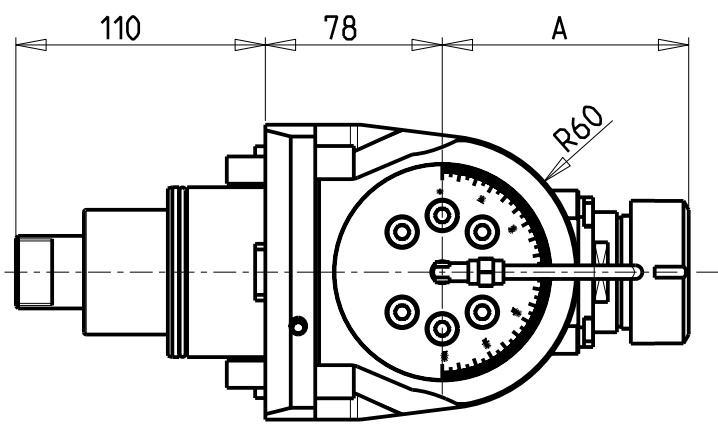

Cod. MT	Mandrino Spindel Spindel	I	RPM	Coppia Max Max Torque Max Drehmoment	Lubrificazione int. Coolant through Innenkuehlung	Lubrificazione est. Ext. coolant Aussenkuehlung	A	CHIAVI INCLUSE Keys included Schluessel inbegriffen					
DW 00820332	ERA32	1:1	6000	50Nm		X	81	CHUB30	CHUB46	CHTAER32ZC	CHESL10	CHESL06	NEW
DW 00820432	ERA32	1:1	6000	50Nm	P=70bar	X	81	CHUB30	CHUB46	CHTAER32ZC	CHESL10	CHESL06	NEW
DW 00820140	ER40	1:1	6000	50Nm		X	108.66	-	CHUB46	CHSTER40	CHESL10	CHESL06	NEW
DW 00820240	ER40	1:1	6000	50Nm	P=70bar	X	108.66	-	CHUB46	CHSTER40	CHESL10	CHESL06	NEW

**HW ACHEON**  
**HI-TECH 550**  
 MODULO MOTORIZZATO ORIENTABILE +/-90°  
 +/-90° adjustable angle driven tool  
 Angetriebenes Werkzeug schwenkbar +/-90°

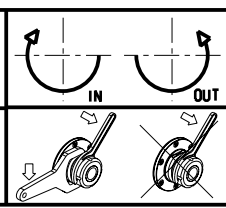

**M.T. srl**  
 Via Casino Albini 480  
 Tel. 0541/956034-957884  
 Fax 0541/956341  
 47842 S. GIOVANNI IN M. (RN)  
 e-mail: mtma@mtmarchetti.com  
 http://www.mtmarchetti.com

PRODUZIONE MODULI ROTANTI

PAGINA HW C339-3-00

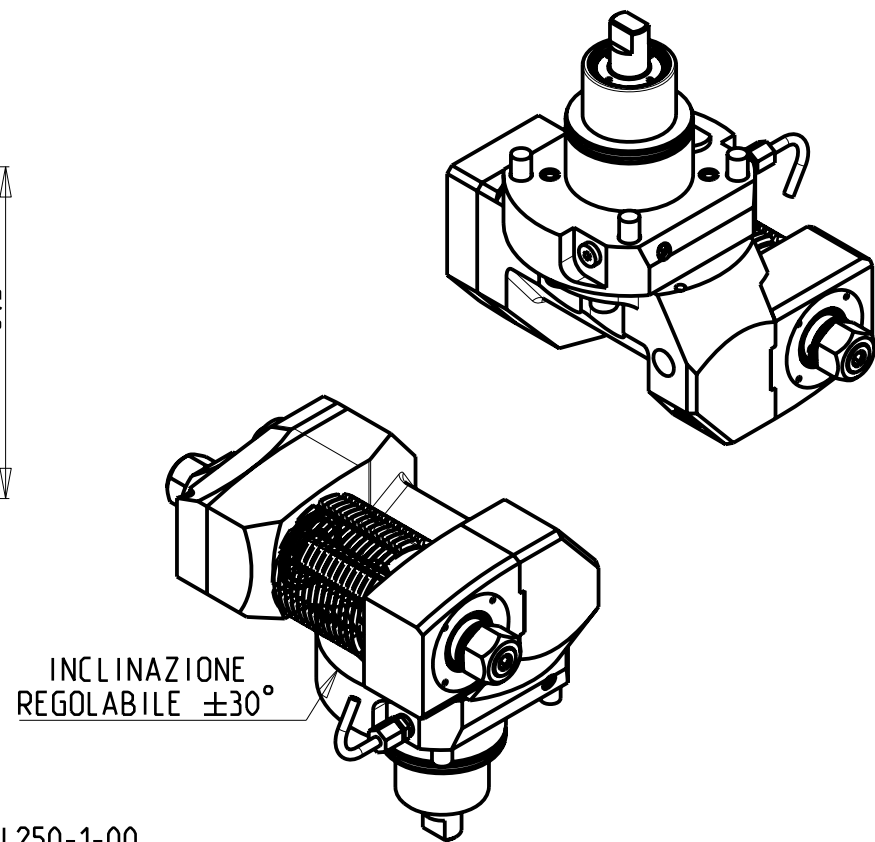
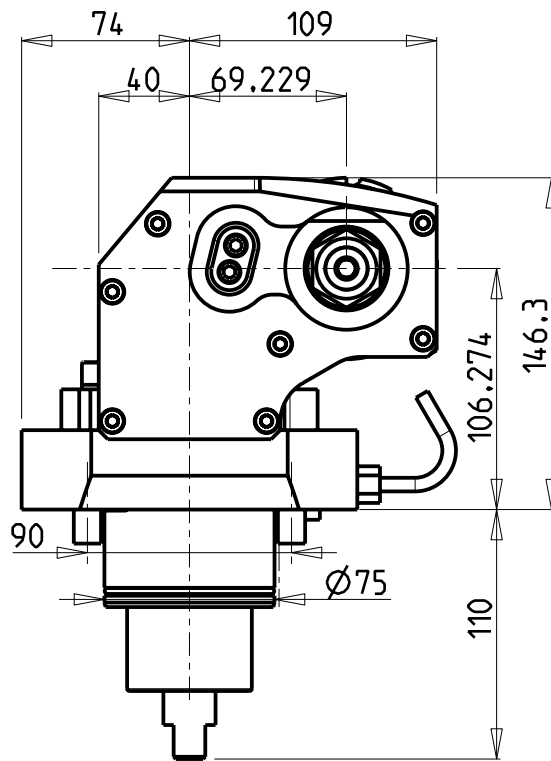
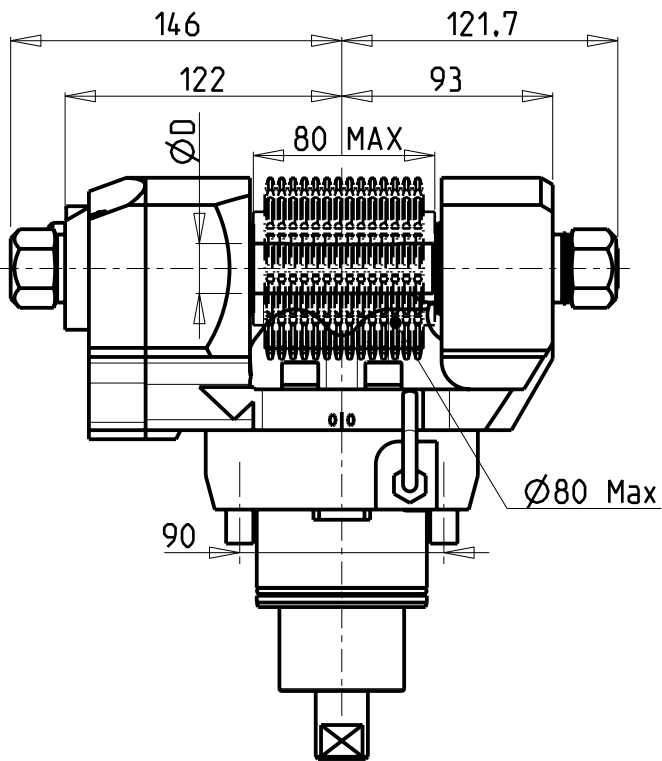

INCLINAZIONE  
REGOLABILE ±30°

**DOTAZIONI - SUPPLIED WITH - AUSSTATTUNG**

- mm / inch
- N°1 ALBERO + DISTANZIALI
  - N°1 SHAFT + SPACER
  - N°1 DORN + ABSTANDSSTUECK

PER ALBERI E DISTANZIALI VEDI PAG. TBL250-1-00  
FOR SHAFT END SPACER SEE PAGE TBL250-1-00  
FUER DORN UND ABSTANDSSTUECK SEITE TBL250-1-00

Cod. MT	I	RPM	Coppia Max Max Torque Max Drehmoment	Reversibile lato mandrino/contromandrino Reversible sub/main spindle side Umkehrbare Spindel-seite/ Gegenspindel-seite	Lubrificazione est. Ext. coolant Aussenkuehlung	D (mm)	D (Inch)	CHIAVI INCLUSE Keys included Schlüssel inbegriffen			
								CHUB30	CHE8L08	CHUB24 (Ø16 / Ø3/4")	
DW 00251100	1:1	6000	90Nm	X	X	16-22-27-32	3/4"-1"-1 1/4"	CHUB30	CHE8L08	CHUB24 (Ø16 / Ø3/4")	NEW
DW 00252100	2:1	3000	110Nm	X	X	16-22-27-32	3/4"-1"-1 1/4"	CHUB30	CHE8L08	CHUB24 (Ø16 / Ø3/4")	NEW

HW ACHEON

HI-TECH 550

MODULO MOTORIZZATO PORTACREATORE MAGGIORATO

Reinforced driven gear hobber

Angetriebenes Zahnradwaelzfraes-Werkzeug vergroessert

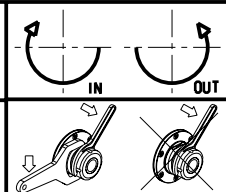

**M.T. srl**

Via Casino Albini 480  
Tel. 0541/956034-957884  
Fax 0541/956341  
47842 S. GIOVANNI IN M. (RN)  
e-mail: mtma@mtmarchetti.com  
http://www.mtmarchetti.com

PRODUZIONE MODULI ROTANTI



PAGINA HWC340-3-60

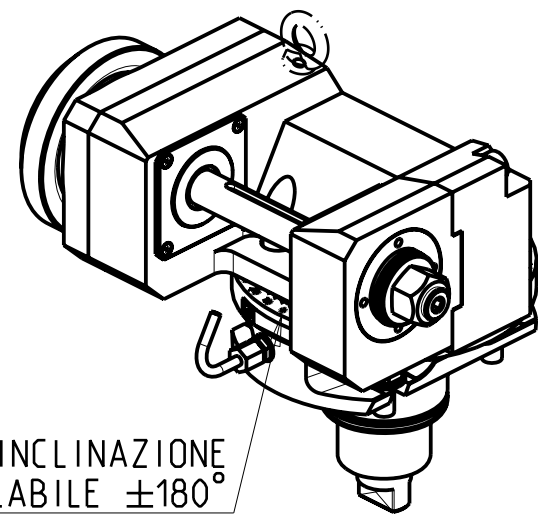
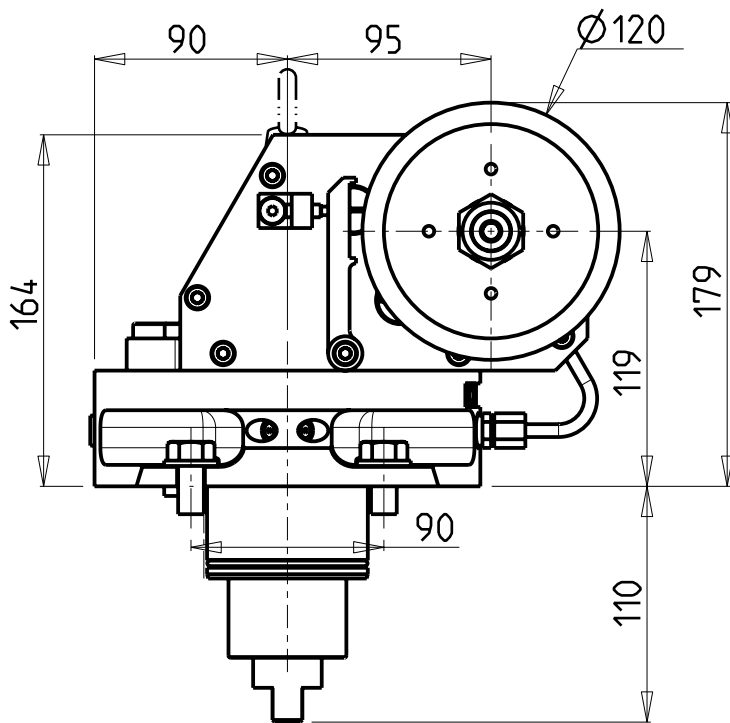
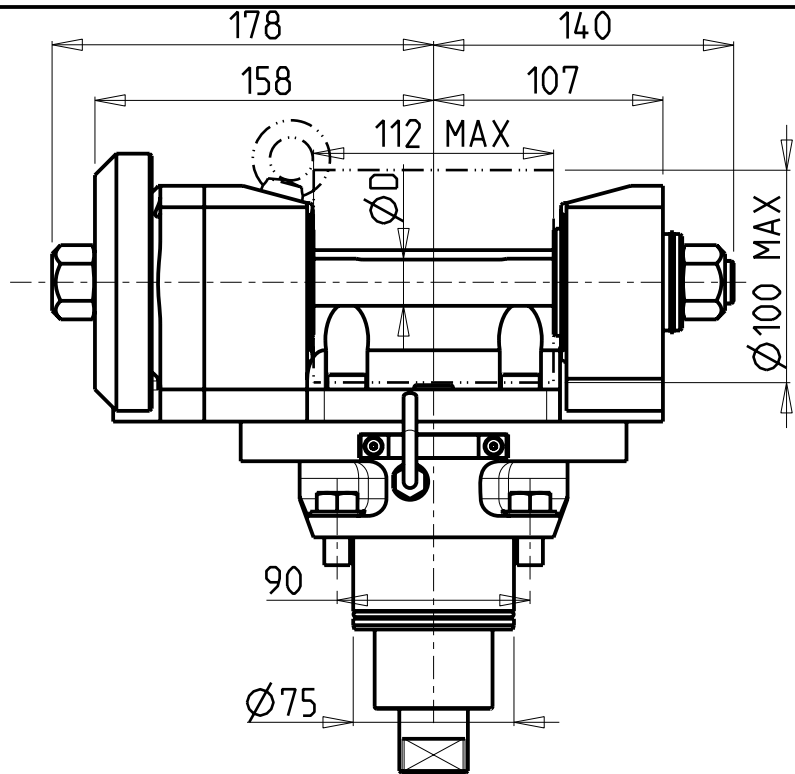

INCLINAZIONE  
REGOLABILE ±180°

**DOTAZIONI - SUPPLIED WITH - AUSSTATTUNG**

mm / inch

- N°1 ALBERO + DISTANZIALI
- N°1 SHAFT + SPACER
- N°1 DORN + ABSTANDSSTUECK

PER ALBERI E DISTANZIALI VEDI PAG. TBL250-1-00  
FOR SHAFT END SPACER SEE PAGE TBL250-1-00  
FUER DORN UND ABSTANDSSTUECK SEITE TBL250-1-00

Cod. MT	I	RPM MAX	Coppia Max Max Torque Max Drehmoment	Lubrificazione est. Ext. coolant Aussenkuehlung	D (mm)	CHIAVI INCLUDE Keys included Schlüssel inbegriffen				
						CHUB30	CHESL08	CHESL10	CHUB19	
DW0081100	1:1	6000	110Nm	X	22-27-32	CHUB30	CHESL08	CHESL10	CHUB19	NEW
DW00812100	2:1	3000	130Nm	X	22-27-32	CHUB30	CHESL08	CHESL10	CHUB19	NEW

HW ACHEON

HI-TECH 550

MODULO MOTORIZZATO PORTACREATORE (TAGLIA GRANDE)

Driven gear hobber (big size)

Angetriebenes Zahnradwaelzfraes-Werkzeug (grosse version)

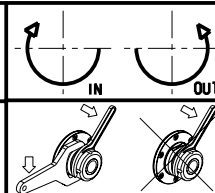

**M.T. srl**

Via Casino Albini 480  
Tel. 0541/956034-957884

Fax 0541/956341

47842 S. GIOVANNI IN M. (RN)

e-mail: mtma@mtmarchetti.com

http://www.mtmarchetti.com

PRODUZIONE MODULI ROTANTI



PAGINA HWC340-3-80



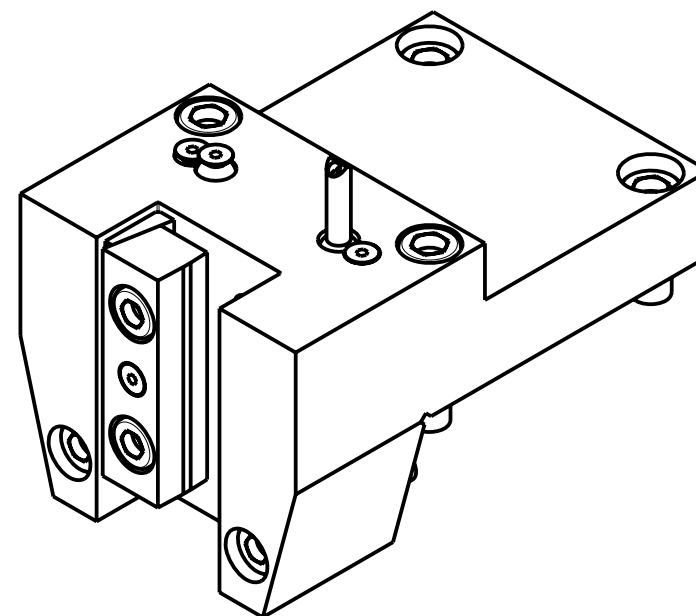
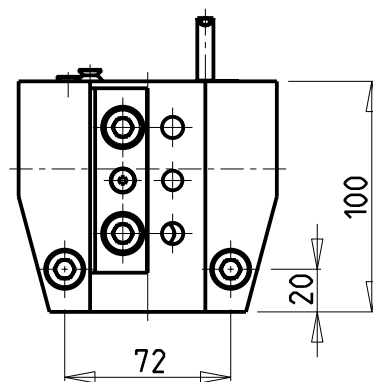
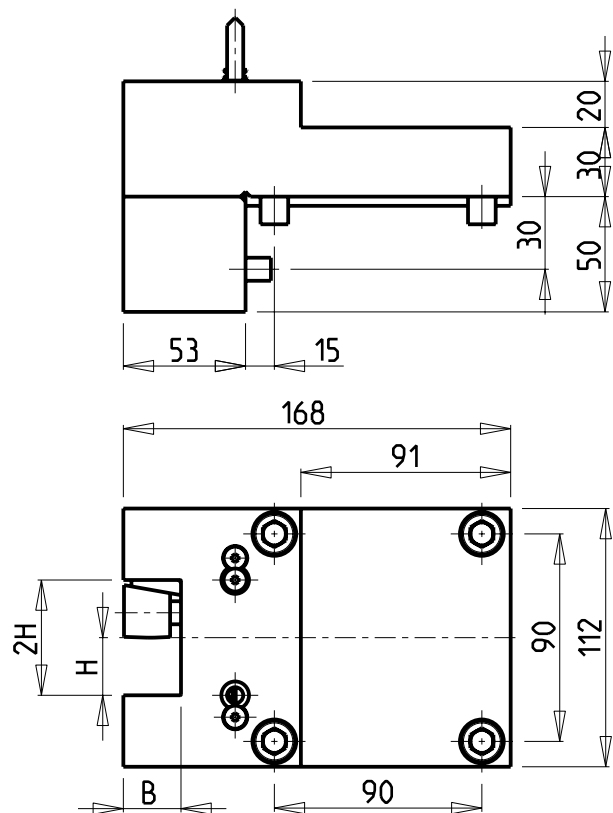

Cod. MT	N°Utensili N°Tools N°Werkzeuge	Misure Dimensions Masse	B	H	
DW 01302500	1	mm	25	25	NEW
DW 01302540	1	Inch	1"	1"	NEW
DW 01303200	1	mm	32	32	NEW
DW 01303175	1	Inch	1-1/4"	1-1/4"	NEW

HW ACHEON

HI-TECH 550

PORTAUTENSILE RADIALE SINGOLO

Radial single static tool

Radial Single-Werkzeughalter

**M.T. srl**

Via Casino Albini 480  
Tel. 0541/956034-957884  
Fax 0541/956341  
47842 S. GIOVANNI IN M. (RN)  
e-mail: mtma@mtmarchetti.com  
http://www.mtmarchetti.com

PRODUZIONE MODULI ROTANTI



PAGINA HWC423-3-00

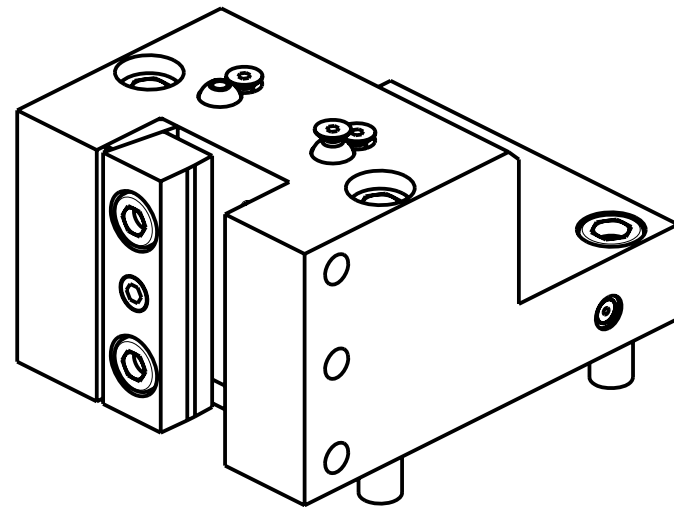
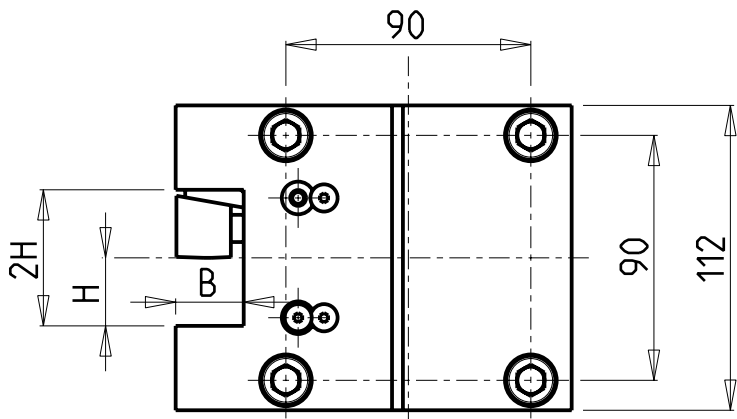
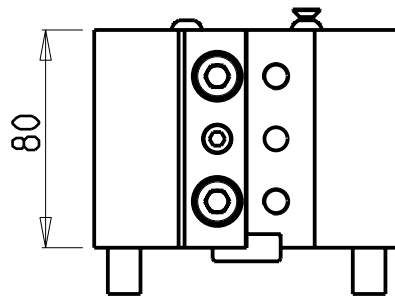
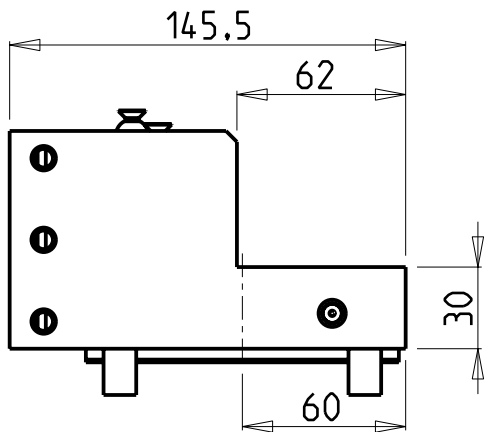

Cod. MT	N°Utensili N°Tools N°Werkzeuge	Reversibile lato mandrino/contromandrino Reversible sub/main spindle side Umkehrbare Spindelseite/ Gegenspindelseite	Misure Dimensions Masse	B	H	
DW 00752500	1	X	mm	25	25	NEW

HW ACHEON  
 HI-TECH 550  
 PORTAUTENSILE RADIALE SINGOLO  
 Radial single static tool  
 Radial Single-Werkzeughalter



**M.T. srl**  
 Via Casino Albini 480  
 Tel. 0541/956034-957884  
 Fax 0541/956341  
 47842 S. GIOVANNI IN M. (RN)  
 e-mail: mtma@mtmarchetti.com  
 http://www.mtmarchetti.com

PRODUZIONE MODULI ROTANTI

PAGINA HWC423-3-01

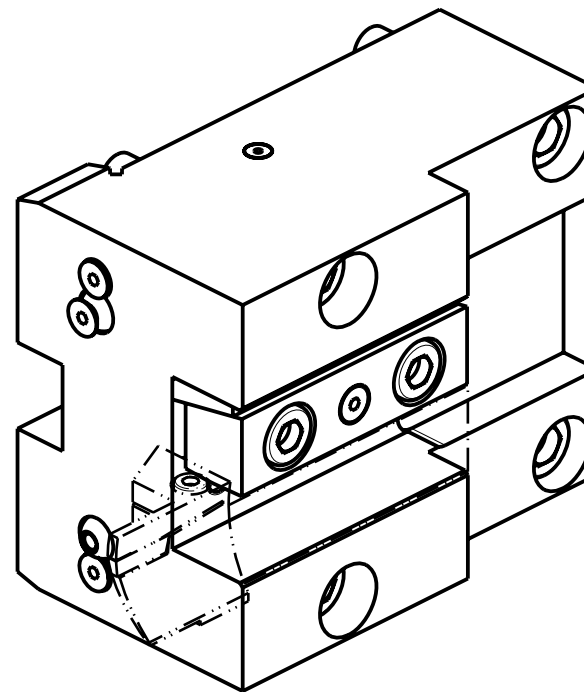
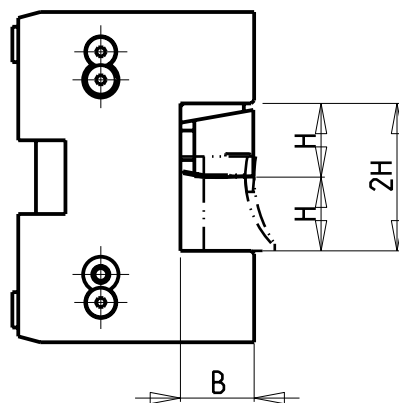
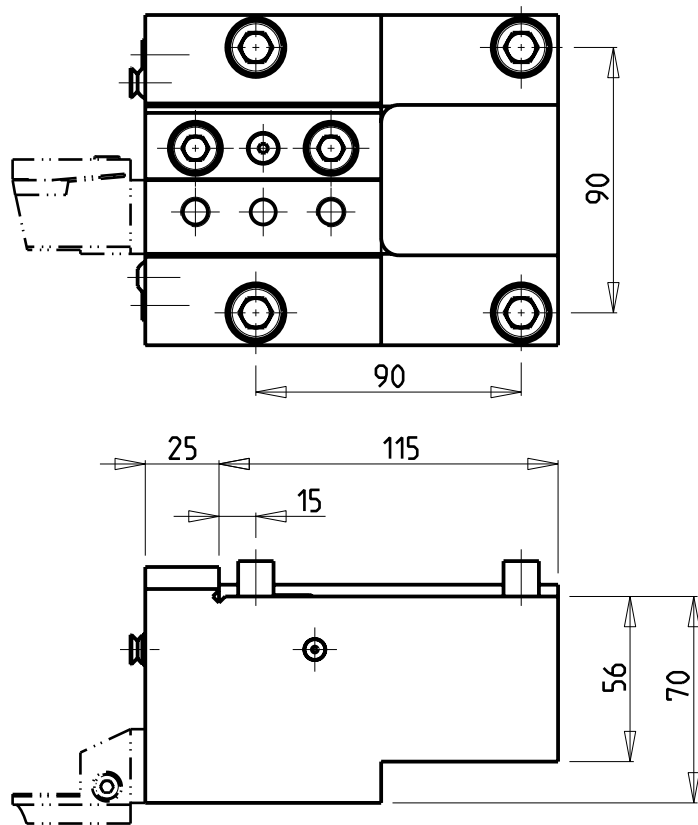

Cod. MT	N°Utensili N°Tools N°Werkzeuge	Reversibile lato mandrino/controlmandrino Reversible sub/main spindle side Umkehrbare Spindel-seite/ Gegenspindel-seite	Misure Dimensions Masse	B	H	
DW 01312500	1	X	mm	25	25	NEW
DW 01312540	1	X	Inch	1"	1"	NEW
DW 01313175	1	X	Inch	1-1/4"	1-1/4"	NEW
DW 01313200	1	X	mm	32	32	NEW

HW ACHEON

HI-TECH 550

PORTAUTENSILE ASSIALE SINGOLO

Axial single static tool

Axial Single-Werkzeughalter

**M.T. srl**

Via Casino Albini 480  
Tel. 0541/956034-957884  
Fax 0541/956341  
47842 S. GIOVANNI IN M. (RN)  
e-mail: mtma@mtmarchetti.com  
http://www.mtmarchetti.com

PRODUZIONE MODULI ROTANTI



PAGINA HW C552-3-00

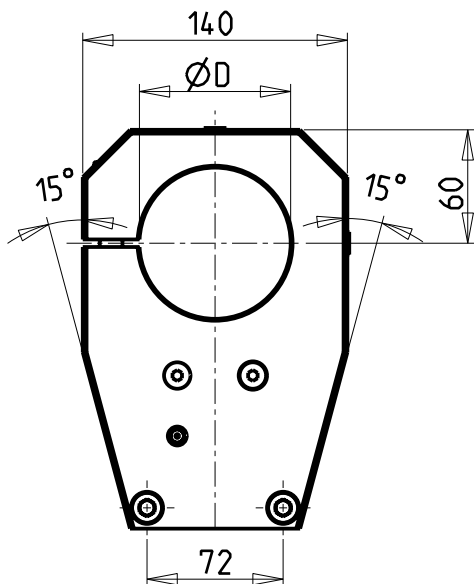
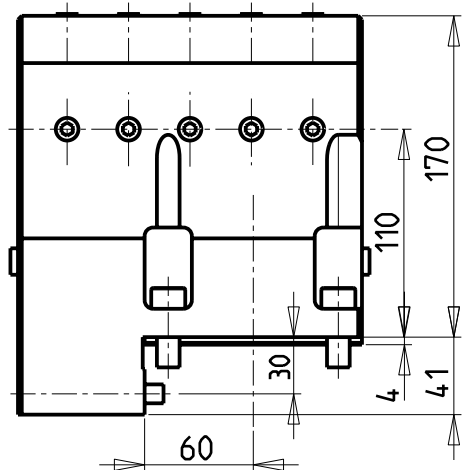
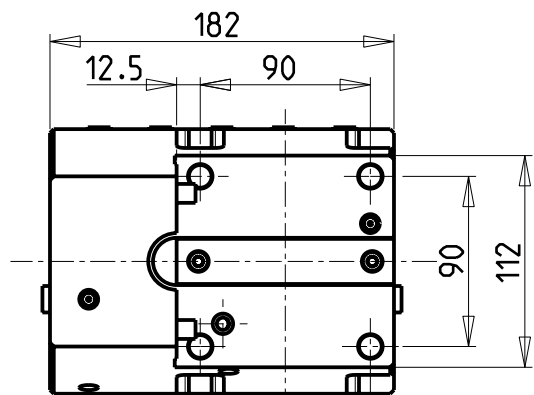

KIT ADDUZIONE INTERNA (OPZIONALE)  
 KIT FOR INTERNAL COOLANT (OPTIONAL)  
 KIT FUER INTERNE KUEHLMITTELZUFUHR (OPTIONAL)  
 Ø80 cod. KIT1005013

SOLO GUARNIZIONE (OPZIONALE)  
 ONLY SEAL (OPTIONAL)  
 NUR DICHTUNG (OPTIONAL)  
 cod. MNL0620002

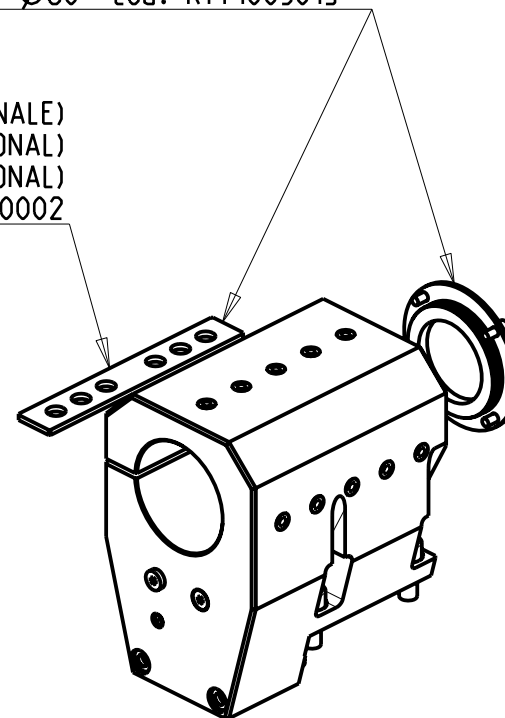

PER BOCCOLE DI RIDUZIONE VEDI PAG. TBL150-1-00  
 FOR REDUCING BUSHINGS SEE PAGE TBL150-1-00  
 FÜR REDUZIERBUCHSE SIEHE SEITE TBL150-1-00

Cod. MT	N°Utensili N°Tools N°Werkzeuge	Lubrificazione int. opzionale Coolant through optional Innenkuehlung Optional	Lubrificazione est. Ext. coolant Aussenkuehlung	Misure Dimensions Masse	D	
DW01328000	1	X	X	mm	80	NEW

HWACHEON

HI-TECH 550

PORTAUTENSILE ASSIALE PER BARENO Ø80mm H=110mm

Axial single boring bar holder Ø80mm H=110mm

Axial Bohrhälter Ø80mm H=110mm

**M.T. srl**

Via Casino Albini 480  
 Tel. 0541/956034-957884  
 Fax 0541/956341

47842 S. GIOVANNI IN M. (RN)  
 e-mail: mtma@mtmarchetti.com  
 http://www.mtmarchetti.com

PRODUZIONE MODULI ROTANTI



PAGINA HWC580-3-20

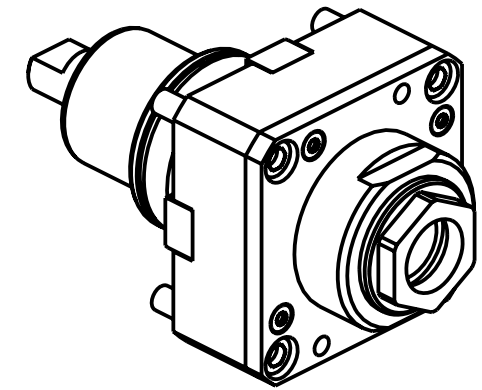
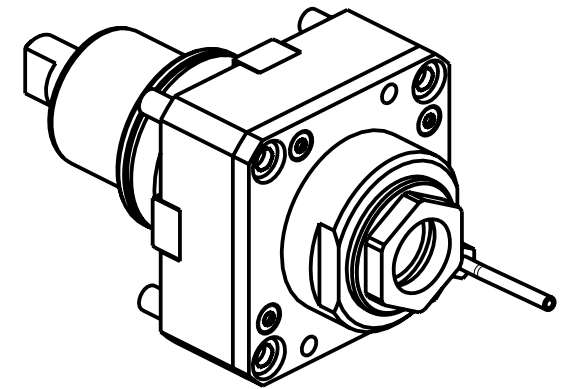
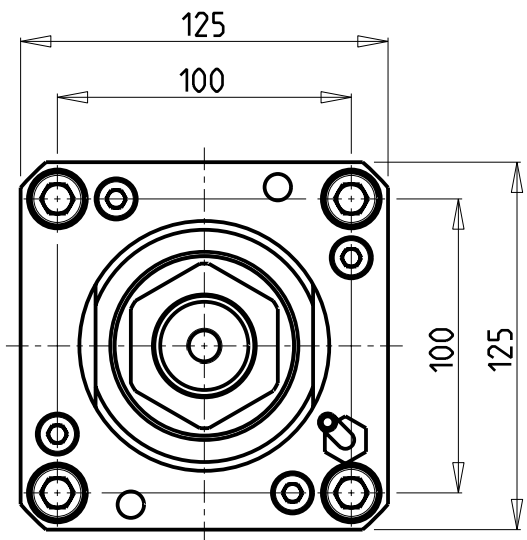
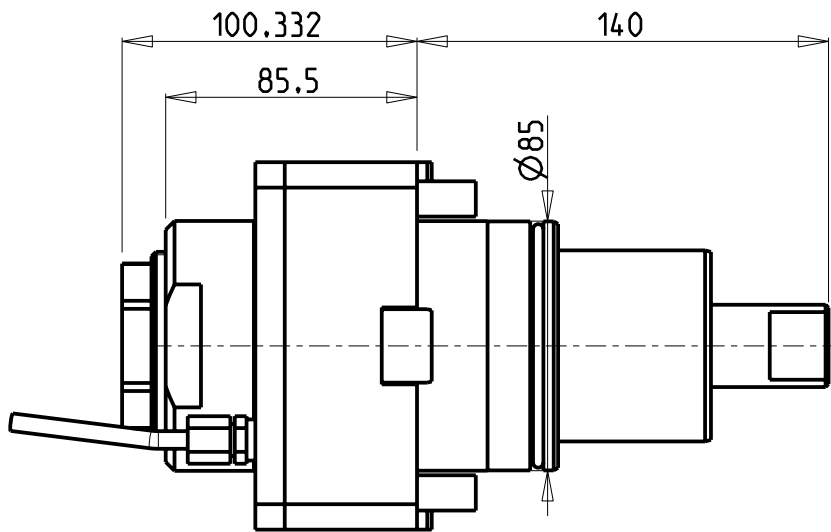

Cod. MT	Mandrino Spindle Spindel	I	RPM	Coppia Max Max Torque Max Drehmoment	Lubrificazione int. Coolant through Innenkuehlung	Lubrificazione est. Ext. coolant Aussenkuehlung	CHIAVI NON INCLUSE Keys not included Schluessel nicht einbegriffen	
DW00160150	ER A 50	1:1	3000	210Nm		X	CHUB50	CHUB74
DW00160250	ER A 50	1:1	3000	210Nm	P=30bar	X	CHUB50	CHUB74

NEW  
NEW

HW ACHEON  
VT950/1150  
MODULO MOTORIZZATO RADIALE  
Radial driven tool  
Radial angetriebenes Werkzeug

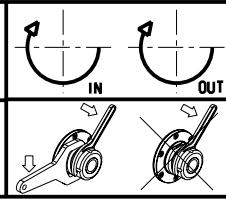

**M.T. srl**  
Via Casino Albini 480  
Tel. 0541/956034-957884  
Fax 0541/956341  
47842 S. GIOVANNI IN M. (RN)  
e-mail: mtma@mtmarchetti.com  
http://www.mtmarchetti.com

PRODUZIONE MODULI ROTANTI



PAGINA HWC010-4-00

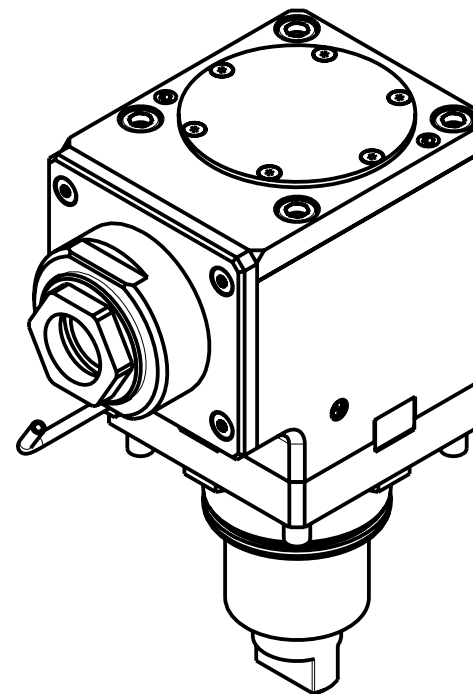
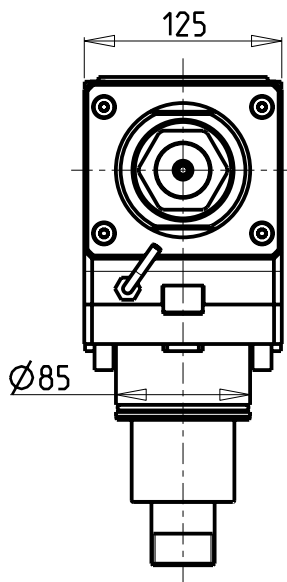
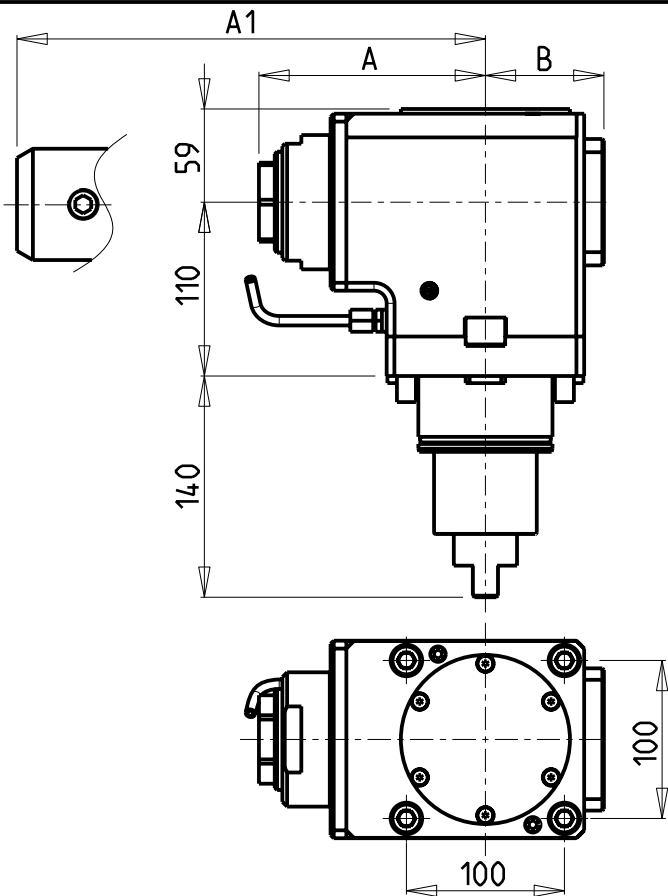

Cod. MT	Mandrino Spindel	I	RPM	Coppia Max Max Torque Max Drehmoment	Reversibile lato mandrino/contromandrino Reversible sub/main spindle side Umkehrbare Spindelseite/ Gegenspindelseite	Lubr.interna Coolant through Innenkuehlung	Lubr. esterna Ext. coolant Aussenkuehlung	A	A1	B	CHIAVI NON INCLUSE Keys not included Schluessel nicht einbegriffen	
DW 01290150	ER A 50	1:1	3000	210Nm	X		X	143.33	-	75	CHUB50	CHUB74
DW 01291250	ER A 50	1:1	3000	210Nm	X	P=70bar	X	143.33	-	86	CHUB50	CHUB74
DW 01290240	Weldon 40	1:1	3000	210Nm	X		X	-	175.5	75	-	-
DW 01290140	Weldon 40	1:1	3000	210Nm	X	P=70bar	X	-	175.5	86	-	-

NEW  
NEW  
NEW  
NEW

HW ACHEON  
VT950/1150

MODULO MOTORIZZATO ASSIALE H=110mm  
Axial driven tool H=110mm  
Axial angetriebenes Werkzeug H=110mm

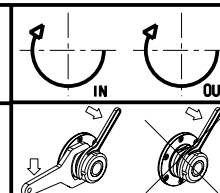

**M.T. srl**  
Via Casino Albini 480  
Tel. 0541/956034-957884  
Fax 0541/956341  
47842 S. GIOVANNI IN M. (RN)  
e-mail: mtma@mtmarchetti.com  
http://www.mtmarchetti.com

PRODUZIONE MODULI ROTANTI



PAGINA HW C 150-4-20

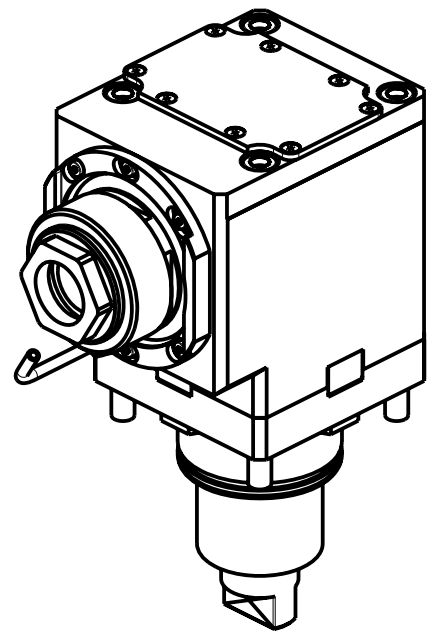
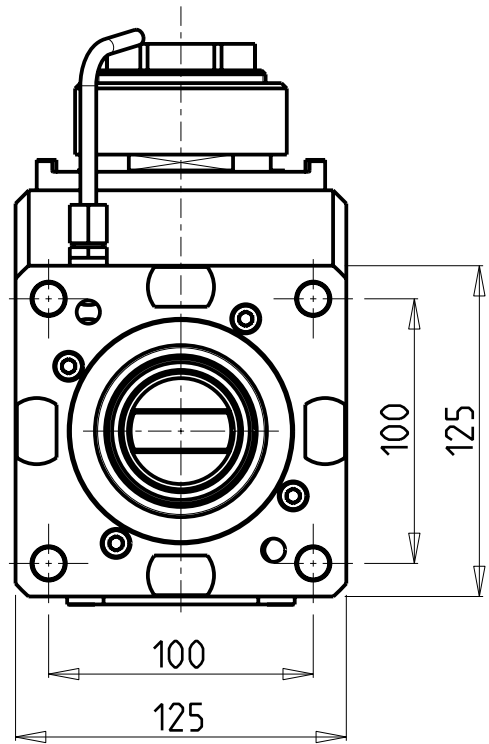
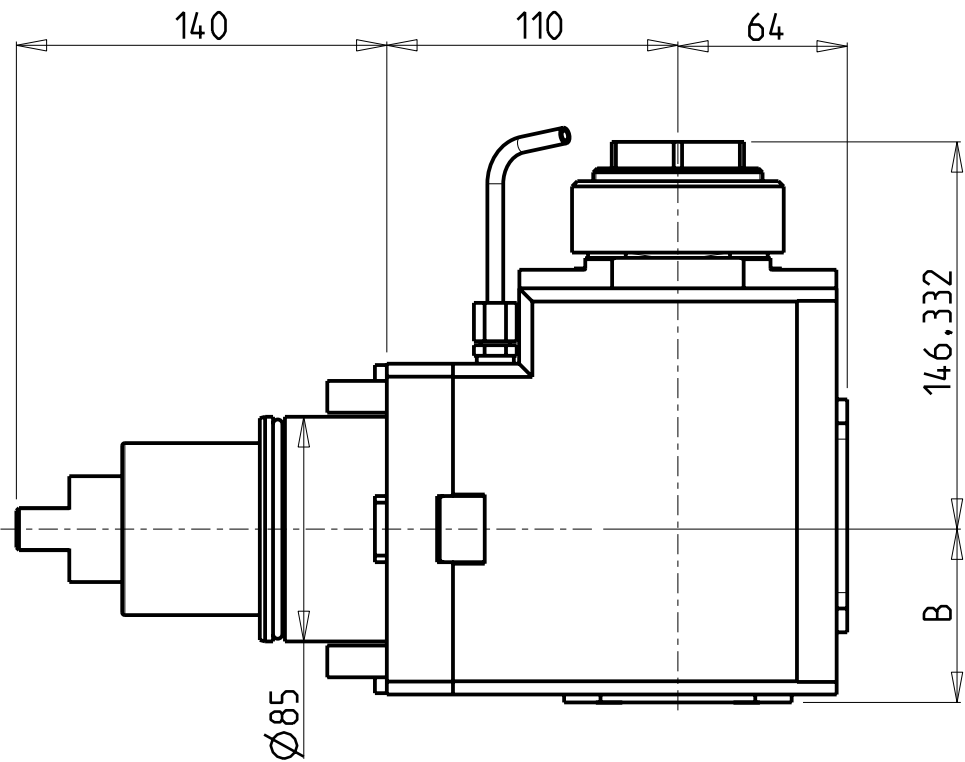

Cod. MT	Mandrino Spindle Spindel	I	RPM	Coppia Max Max Torque Max Drehmoment	Reversibile lato mandrino/contromandrino Reversible sub/main spindle side Umkehrbare Spindel-seite/ Gegen-spindel-seite	Lubrificazione int. Coolant through Innenkühlung	Lubrificazione est. Ext. coolant Aussenkühlung	B	CHIAVI NON INCLUSE Keys not included Schlüssel nicht einbegriffen	
DW 01210150	ER A 50	2:1	1500	300Nm	X		X	65.5	CHUB50	NZL0010023 •
DW 01210250	ER A 50	2:1	1500	300Nm	X	P=70bar	X	82	CHUB50	NZL0010023 •

- Chiave inclusa
- Key included
- Schlüssel inbegriffen

**HW ACHEON**  
**VT950/1150**  
 MODULO MOTORIZZATO ASSIALE RIDOTTO I=2:1 H=110mm  
 Axial geared-down I=2:1 driven tool H=110mm  
 Axial angetriebenes Werkzeug untersetzt I=2:1 H=110mm

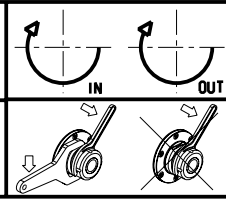

**M.T. srl**  
 Via Casino Albini 480  
 Tel. 0541/956034-957884  
 Fax 0541/956341  
 47842 S. GIOVANNI IN M. (RN)  
 e-mail: mtma@mtmarchetti.com  
 http://www.mtmarchetti.com

PRODUZIONE MODULI ROTANTI



PAGINA HW C 190-4-20

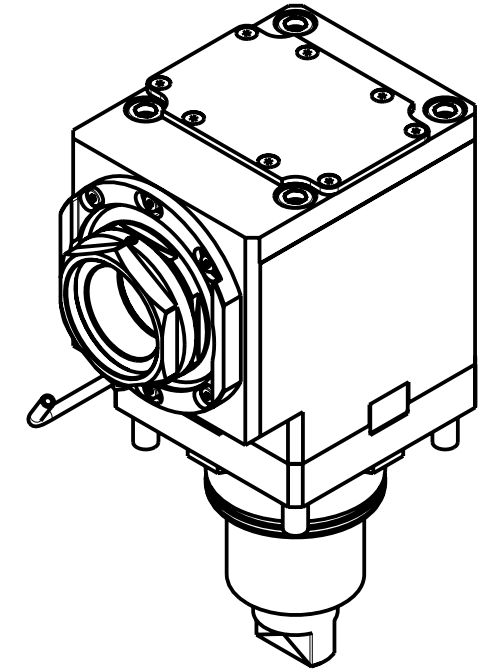
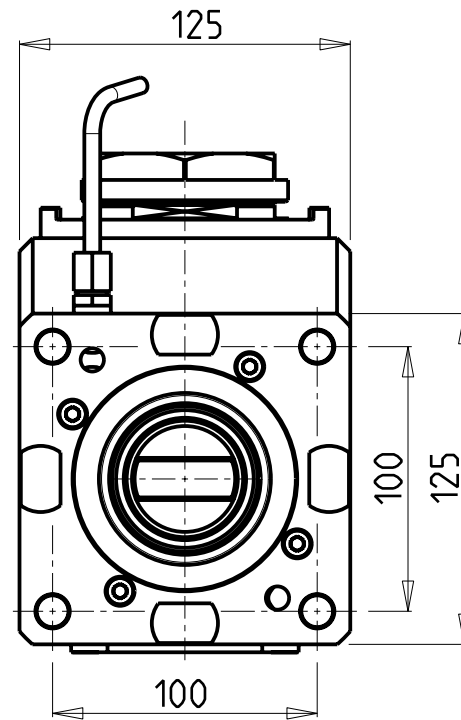
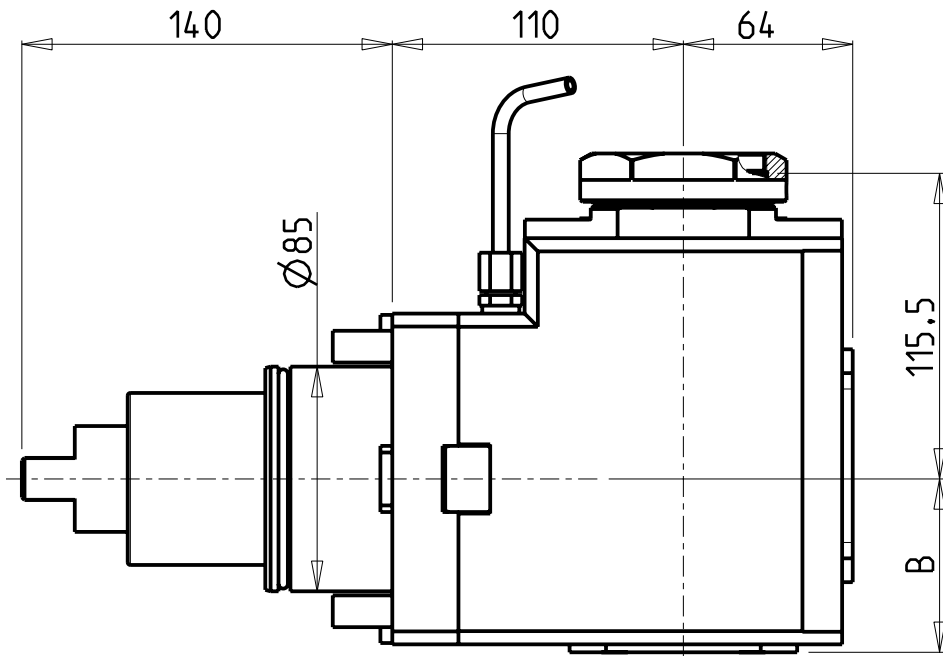

PER PORTAUTENSILI MODULARI MTSK-63 VEDI PAG. TBL300-1-63  
 FOR MTSK-63 QUICK CHANGE TOOLHOLDERS CLAMPINGS SEE PAGE TBL300-1-63  
 FÜR MTSK-63 MODULARE WERKZEUGAUFNAHMEN SIEHE SEITE TBL300-1-63

Cod. MT	Mandrino Spindle Spindel	I	RPM	Coppia Max Max Torque Max Drehmoment	Reversibile lato mandrino/contromandrino Reversible sub/main spindle side Umkehrbare Spindel-seite/ Gegen-spindel-seite	Lubrificazione int. Coolant through Innenkühlung	Lubrificazione est. Ext. coolant Aussenkühlung	B	CHIAVI NON INCLUSE Keys not included Schlüssel nicht einbegriffen	
DW01200163	MTSK-63	2:1	1500	300Nm	X		X	65.5	CHUB68	NZL0010023 •
DW01200263	MTSK-63	2:1	1500	300Nm	X	P=70bar	X	82	CHUB68	NZL0010023 •

- Chiave inclusa
- Key included
- Schlüssel inbegriffen

NEW  
NEW

HW ACHEON  
VT950/1150

MODULO MOTORIZZATO ASSIALE MTSK RIDOTTO I=2:1 H=110mm  
 Axial MTSK geared-down I=2:1 driven tool H=110mm  
 Axial MTSK angetriebenes Werkzeug untersetzt I=2:1 H=110mm

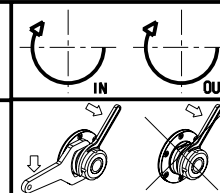

**M.T. srl**  
 Via Casino Albini 480  
 Tel. 0541/956034-957884  
 Fax 0541/956341  
 47842 S. GIOVANNI IN M. (RN)  
 e-mail: mtma@mtmarchetti.com  
 http://www.mtmarchetti.com

PRODUZIONE MODULI ROTANTI



PAGINA HWC190-4-20-K



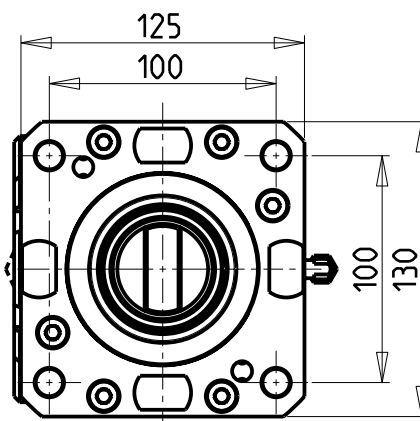
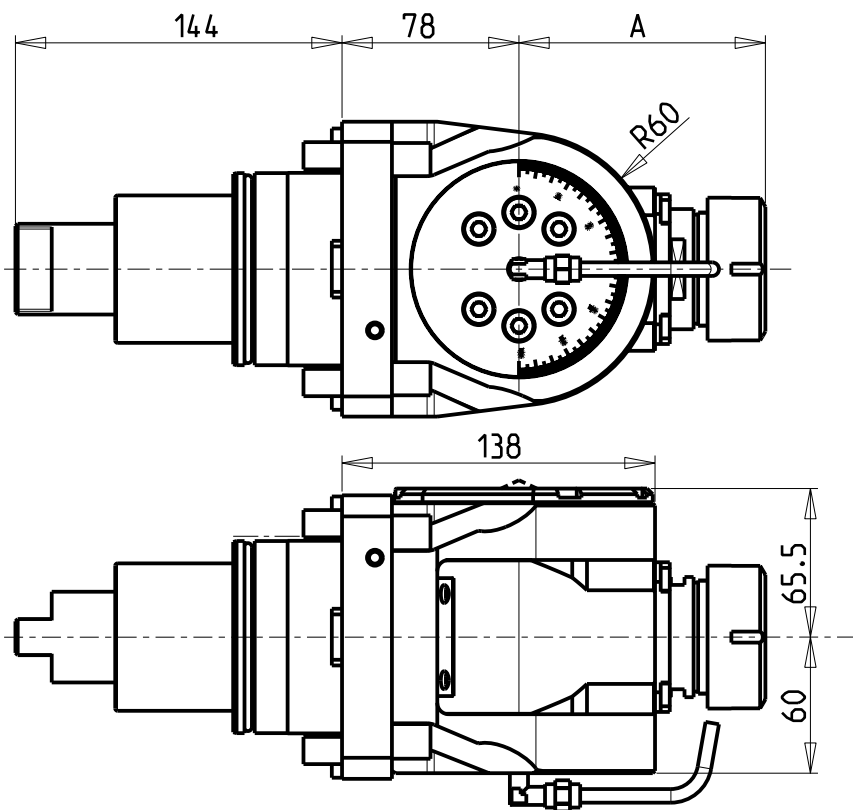

**ATTENZIONE - ATTENTION - ACHTUNG**

- Per lo smontaggio degli utensili utilizzare sempre la chiave di contrasto come indicato nel manuale d'uso.
- For disassembly of the tools use always the contrast key as mentioned in the user instructions.
- Fuer das Abmontieren der Werkzeuge immer den Gegenschlüssel benutzen wie in der Bedienungsanleitung erwäehnt.

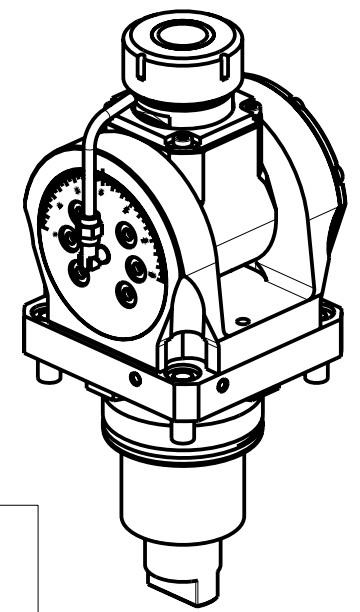

Cod. MT	Mandrino Spindel Spindel	I	RPM	Coppia Max Max Torque Max Drehmoment	Lubrificazione int. Coolant through Innenkuehlung	Lubrificazione est. Ext. coolant Aussenkuehlung	A	CHIAVI INCLUSE Keys included Schluessel inbegriffen					
DW 00830332	ERA32	1:1	3000	50Nm		X	81	CHUB30	CHUB46	CHTAER32ZC	CHESL10	CHESL06	NEW
DW 00830432	ERA32	1:1	3000	50Nm	P=70bar	X	81	CHUB30	CHUB46	CHTAER32ZC	CHESL10	CHESL06	NEW
DW 00830140	ER40	1:1	3000	50Nm		X	108.66	-	CHUB46	CHSTER40	CHESL10	CHESL06	NEW
DW 00830240	ER40	1:1	3000	50Nm	P=70bar	X	108.66	-	CHUB46	CHSTER40	CHESL10	CHESL06	NEW

HW ACHEON  
VT950/1150

MODULO MOTORIZZATO ORIENTABILE +/-90°  
+/-90° adjustable angle driven tool  
Angetriebenes Werkzeug schwenkbar +/-90°

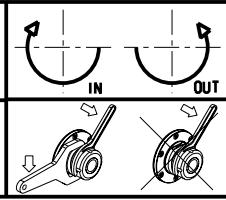

**M.T. srl**  
Via Casino Albini 480  
Tel. 0541/956034-957884  
Fax 0541/956341  
47842 S. GIOVANNI IN M. (RN)  
e-mail: mtma@mtmarchetti.com  
http://www.mtmarchetti.com

PRODUZIONE MODULI ROTANTI

PAGINA HW C339-4-00

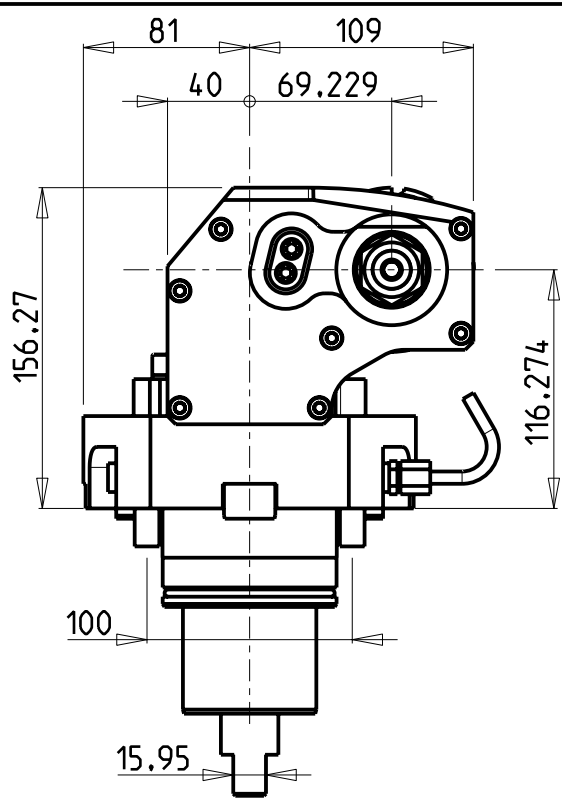
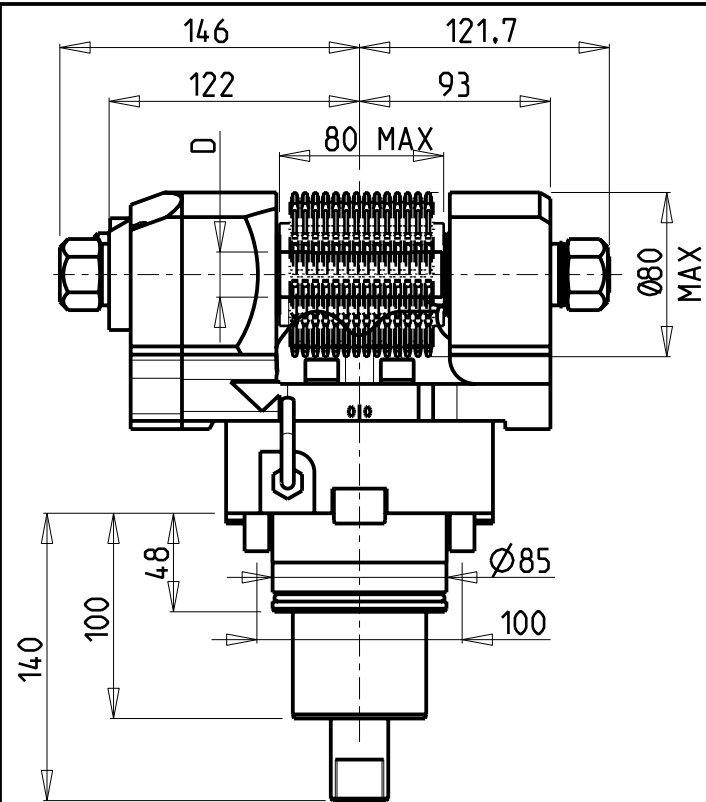

INCLINAZIONE  
REGOLABILE ±30°

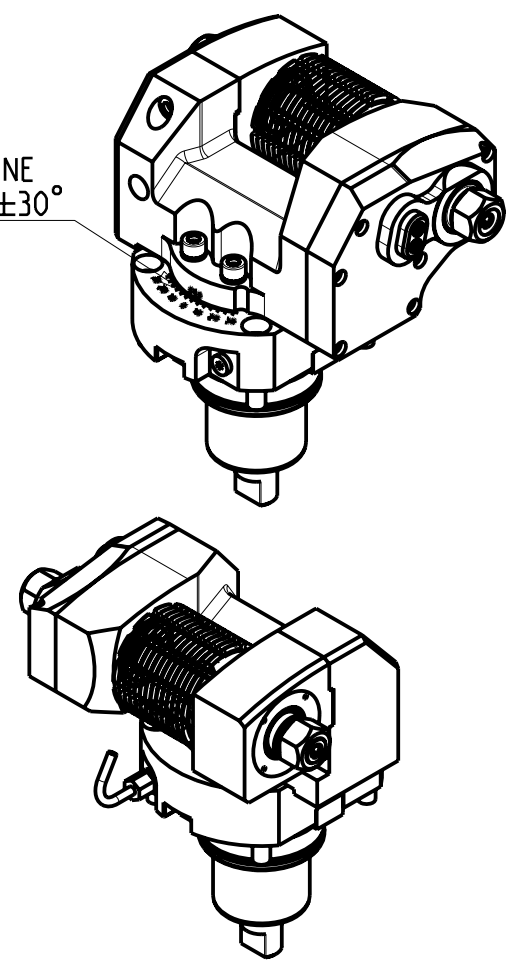

**DOTAZIONI - SUPPLIED WITH - AUSSTATTUNG**

mm / inch	- N°1 ALBERO + DISTANZIALI - N°1 SHAFT + SPACER - N°1 DORN + ABSTANDSSTUECK
-----------	---

PER ALBERI E DISTANZIALI VEDI PAG. TBL250-1-00  
FOR SHAFT END SPACER SEE PAGE TBL250-1-00  
FUER DORN UND ABSTANDSSTUECK SEITE TBL250-1-00

Cod. MT	I	RPM max	Coppia Max Max Torque Max Drehmoment	Lubrificazione est. Ext. coolant Aussenkuehlung	D (mm)	D (Inch)	CHIAVI INCLUSE Keys included Schlüssel inbegriffen				
							CHUB30	CHESL08	CHESL10	CHUB24 (Ø16 / Ø3/4")	
DW 00181100	1:1	3000	90Nm	X	16-22-27-32	3/4"-1"-1 1/4"	CHUB30	CHESL08	CHESL10	CHUB24 (Ø16 / Ø3/4")	NEW
DW 00182100	2:1	1500	110Nm	X	16-22-27-32	3/4"-1"-1 1/4"	CHUB30	CHESL08	CHESL10	CHUB24 (Ø16 / Ø3/4")	NEW

HW ACHEON  
VT950/1150

MODULO MOTORIZZATO PORTACREATORE MAGGIORATO  
Reinforced driven gear hobber  
Angetriebenes Zahnradwaelzfraes-Werkzeug vergroessert

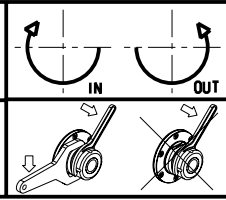

**M.T. srl**  
Via Casino Albini 480  
Tel. 0541/956034-957884  
Fax 0541/956341  
47842 S. GIOVANNI IN M. (RN)  
e-mail: mtma@mtmarchetti.com  
http://www.mtmarchetti.com

PRODUZIONE MODULI ROTANTI



PAGINA HWC340-4-60

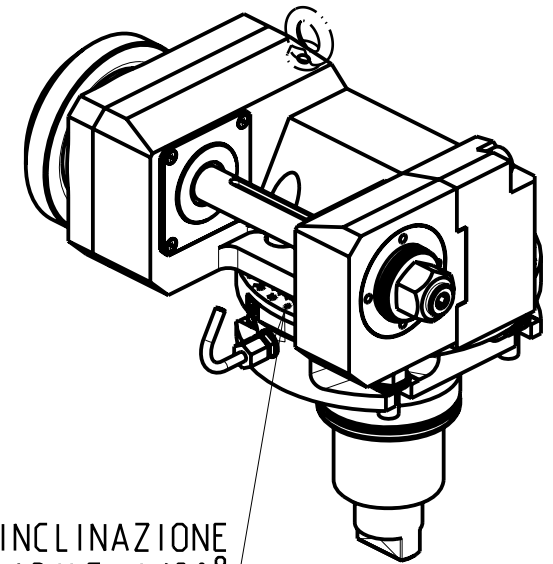
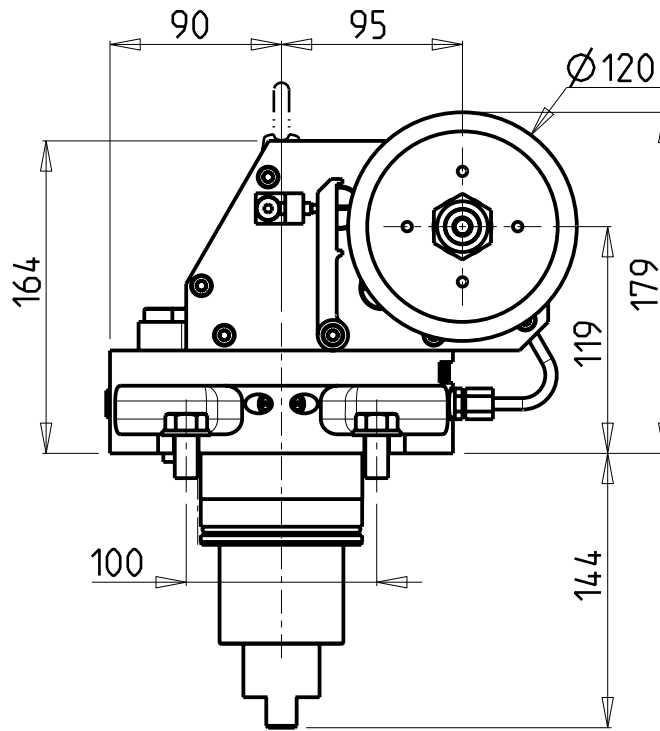
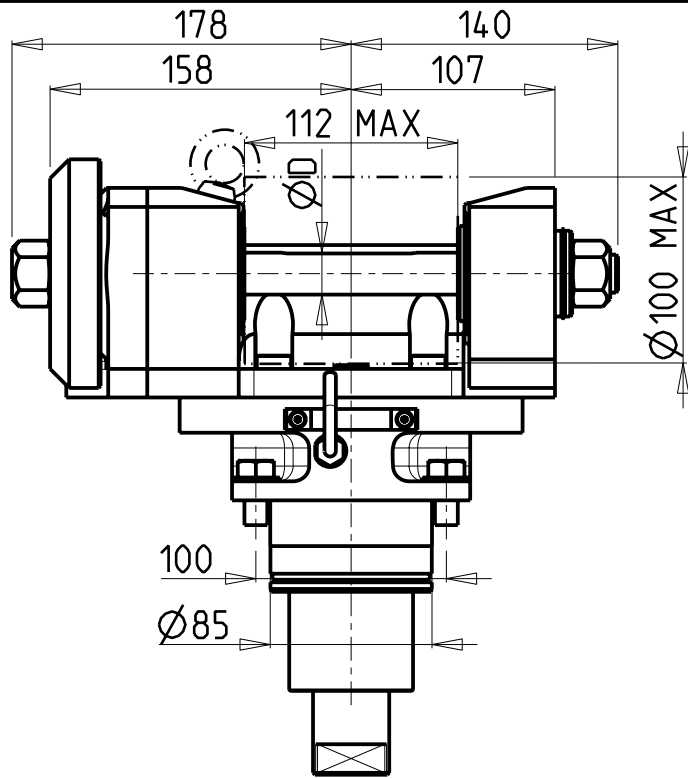

INCLINAZIONE  
REGOLABILE  $\pm 180^\circ$

**DOTAZIONI - SUPPLIED WITH - AUSSTATTUNG**

mm / inch

- N°1 ALBERO + DISTANZIALI
- N°1 SHAFT + SPACER
- N°1 DORN + ABSTANDSSTUECK

PER ALBERI E DISTANZIALI VEDI PAG. TBL250-1-00  
FOR SHAFT END SPACER SEE PAGE TBL250-1-00  
FUER DORN UND ABSTANDSSTUECK SEITE TBL250-1-00

Cod. MT	I	RPM MAX	Coppia Max Max Torque Max Drehmoment	Lubrificazione est. Ext. coolant Aussenkuehlung	D (mm)	CHIAVI INCLUSE Keys included Schlüssel inbegriffen				
						CHUB30	CHESL08	CHESL10	CHUB19	
DW00851100	1:1	3000	110Nm	X	22-27-32	CHUB30	CHESL08	CHESL10	CHUB19	NEW
DW00852100	2:1	1500	130Nm	X	22-27-32	CHUB30	CHESL08	CHESL10	CHUB19	NEW

HW ACHEON  
VT950/1150

MODULO MOTORIZZATO PORTACREATORE (TAGLIA GRANDE)  
Driven gear hobber (big size)  
Angetriebenes Zahnradwaelzfraes-Werkzeug (grosse version)

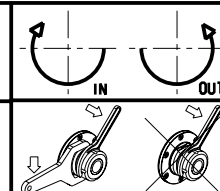

**M.T. srl**

Via Casino Albini 480  
Tel. 0541/956034-957884

Fax 0541/956341

47842 S. GIOVANNI IN M. (RN)  
e-mail: mtma@mtmarchetti.com  
http://www.mtmarchetti.com

PRODUZIONE MODULI ROTANTI



PAGINA HWC340-4-80