

		PAGINA Page Seite
<p>MODULO MOTORIZZATO ASSIALE 3 USCITE Axial multiple 3 outlet driven tool Axial angetriebenes Mehrspindel-Werkzeug 3 Ausgaenge</p>		NOM265.1.10 NEW
<p>MODULO MOTORIZZATO ORIENTABILE ±90° ±90° adjustable angle driven tool Angetriebenes Werkzeug schwenkbar ±90°</p>		NOM335.1.00
<p>MODULO MOTORIZZATO ORIENTABILE DOPPIO ±90° ±90° double adjustable angle driven tool Doppel-Angetriebenes Werkzeug schwenkbar ±90°</p>		NOM338.1.00
<p>MODULO MOTORIZZ. ORIENTABILE DOPPIO ±90° PER CONTROMANDRINO ±90° double adjustable angle driven tool for subspindle Doppel-Angetriebenes Werkzeug schwenkbar ±90° fuer Gegenspindle</p>		NOM338.1.10 NEW
<p>MODULO MOTORIZZ. ORIENTABILE TRIPLO ±90° ±90° triple adjustable angle driven tool Dreifach-Angetriebenes Werkzeug schwenkbar ±90°</p>		NOM338.1.20 NEW
<p>MODULO MOTORIZZATO PORTACREATORE Driven gear hobber Angetriebenes Zahnradwaelzfraes-Werkzeug</p>		NOM340.1.00 NEW
<p>MODULO MOTORIZZATO TURBINATORE RIDOTTO 1=2:1 Driven whirling tool geared-down 1=2:1 Gewindewirbeleinrichtung untersetzt 1=2:1</p>		NOM370.1.00 NEW

		PAGINA Page Seite
<p>MODULO MOTORIZZ. ORIENTABILE DOPPIO $\pm 90^\circ$ $\pm 90^\circ$ double adjustable angle driven tool Doppel-Angetriebenes Werkzeug schwenkbar $\pm 90^\circ$</p>		NOM338.2.00 

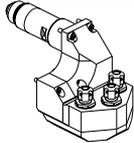
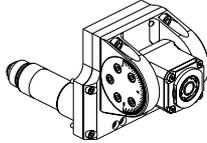
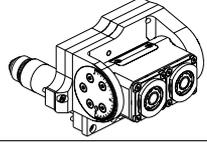
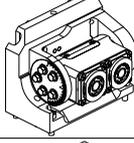
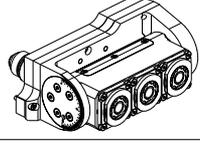
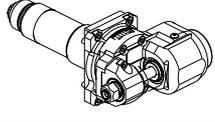
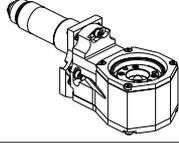
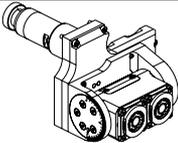
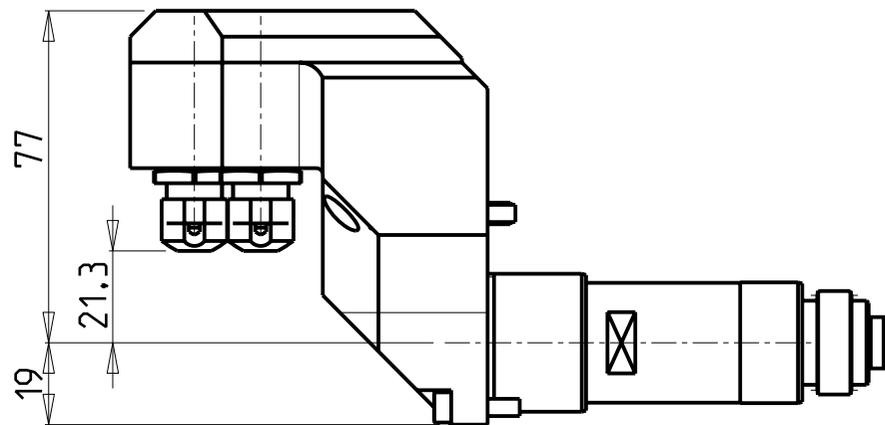
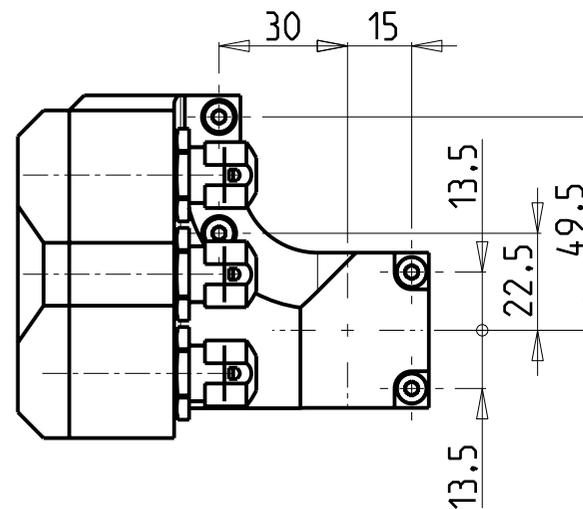
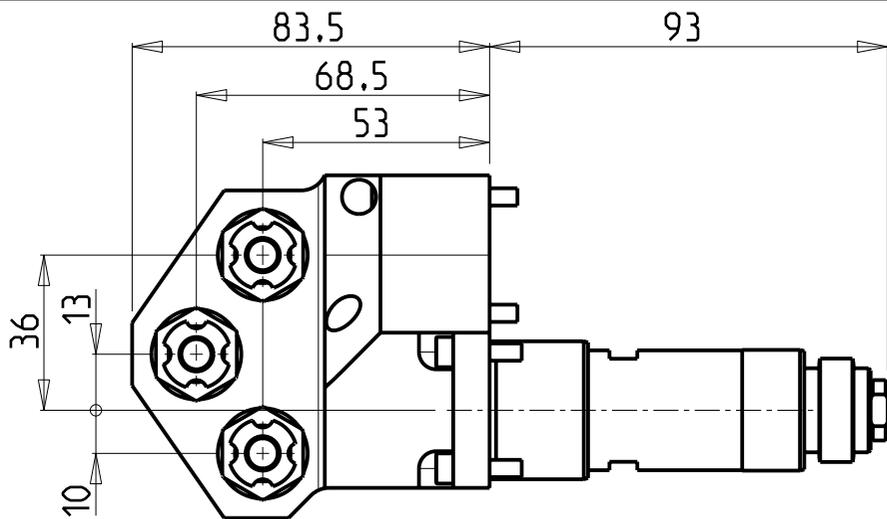

ATTENZIONE - ATTENTION - ACHTUNG

- Per lo smontaggio degli utensili utilizzare sempre la chiave di contrasto come indicato nel manuale d'uso.
- For disassembly of the tools use always the contrast key as mentioned in the user instructions.
- Fuer das Abmontieren der Werkzeuge immer den Gegenschlüssel benutzen wie in der Bedienungsanleitung erwäehnt.

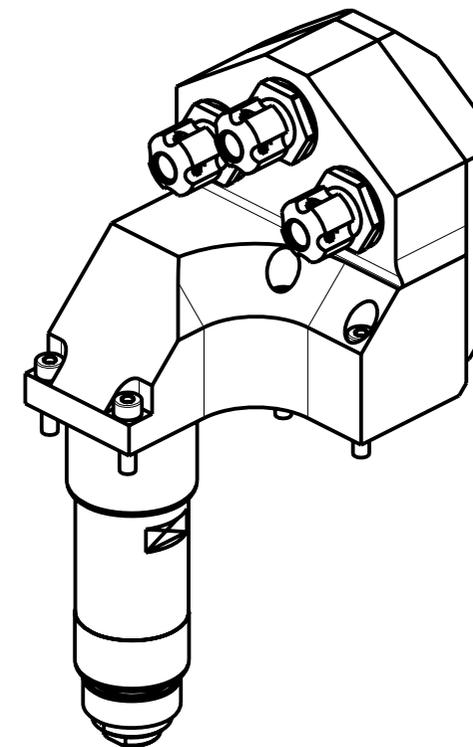

Cod. MT	Mandrino Spindle Spindel	I	RPM	N°Utensili N°Tools N°Werkzeuge	Lubr.esterna Ext. coolant Aussenkeuhlung	CHIAVI NON INCLUSE Keys not included Schlüssel nicht einbegriffen	
SPC0991000	ER11	1:1	6000	3	X	CHMNER11	CHUB19_SP3

NEW

NOMURA

MOD: NN20J - NN20J2 - NN20JS

MODULO MOTORIZZATO ASSIALE 3 USCITE

Axial multiple 3 outlet driven tool

Axial angetriebenes Mehrspindel-Werkzeug 3 Ausgaenge

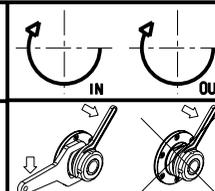

M.T. srl

Via Casino Albini 480
Tel. 0541/956034-957884
Fax 0541/956341

47842 S. GIOVANNI IN M. (RN)
e-mail: mtma@mtmarchetti.com
http://www.mtmarchetti.com

PRODUZIONE MODULI ROTANTI



PAGINA NOM265-1-10

ATTENZIONE - ATTENTION - ACHTUNG

- Per lo smontaggio degli utensili utilizzare sempre la chiave di contrasto come indicato nel manuale d'uso.
- For disassembly of the tools use always the contrast key as mentioned in the user instructions.
- Fuer das Abmontieren der Werkzeuge immer den Gegenschlüssel benutzen wie in der Bedienungsanleitung erwaeht.

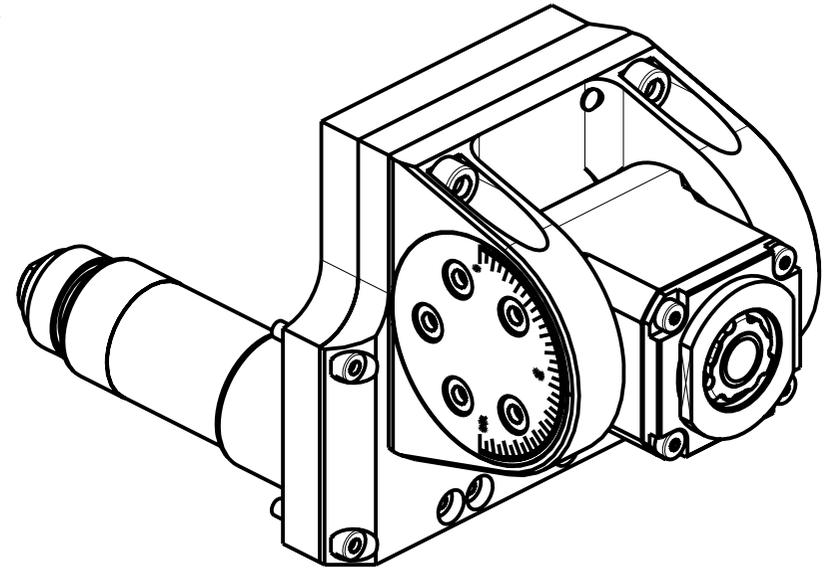
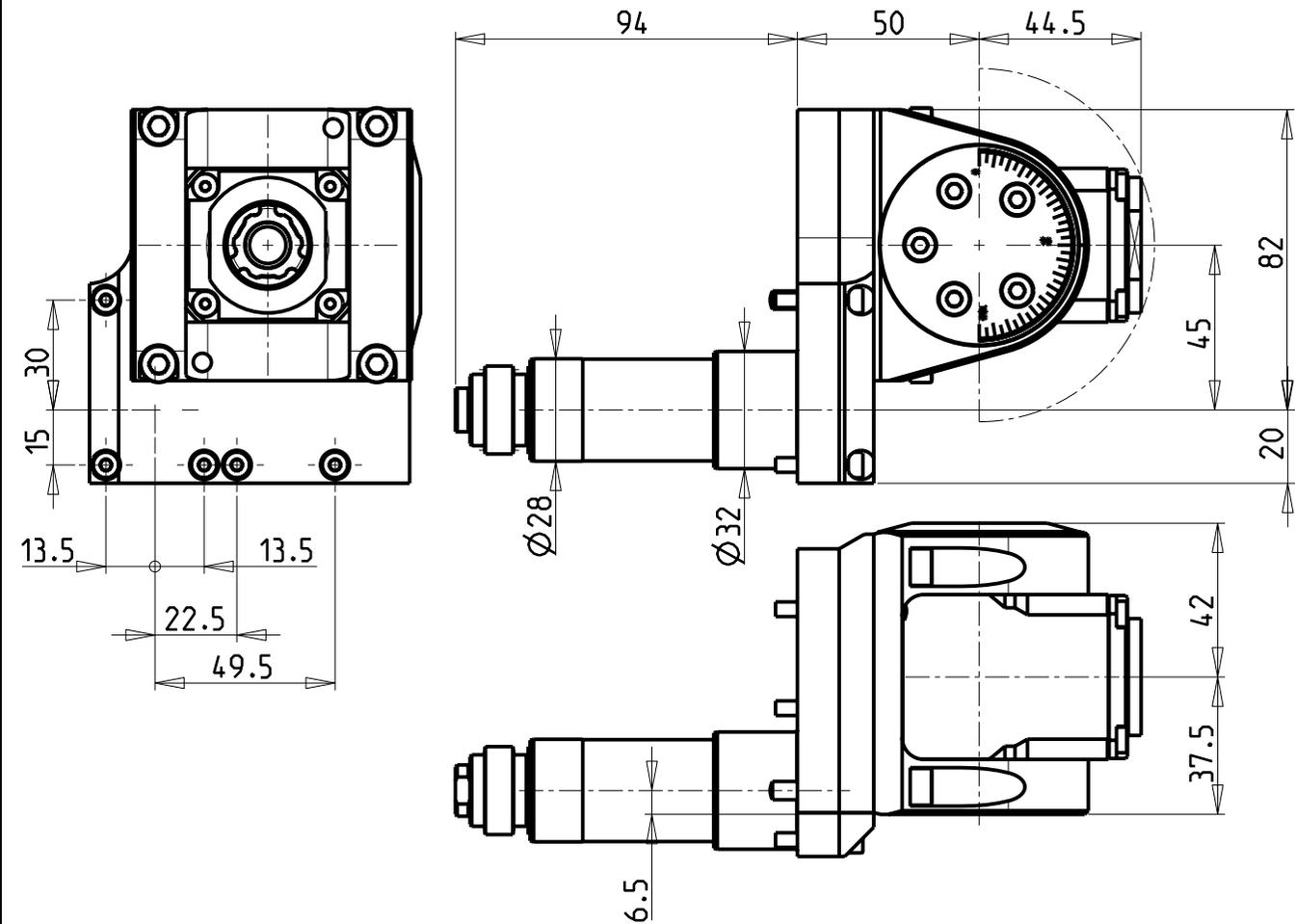

Cod. MT	Mandrino Spindle Spindel	I	RPM	Lubrificazione est. Ext. coolant Aussenkuehlung	CHIAVI INCLUSE Keys included Schluessel inbegriffen		
SPC0801000	ERA16	1:1	6000	X	CHUB32	CHUB19_SP3	CHTAER16ZC

NOMURA
MOD: NN20J - NN20J2 - NN20JS

MODULO MOTORIZZATO ORIENTABILE ±90°
±90° adjustable angle driven tool
Angetriebenes Werkzeug schwenkbar ±90°

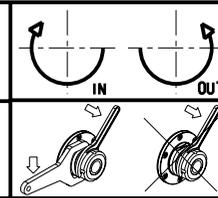

M.T. srl
Via Casino Albini 480
Tel. 0541/956034-957884
Fax 0541/956341
47842 S. GIOVANNI IN M. (RN)
e-mail: mtma@mtmarchetti.com
http://www.mtmarchetti.com

PRODUZIONE MODULI ROTANTI



PAGINA NOM335-1-00

ATTENZIONE - ATTENTION - ACHTUNG

- Per lo smontaggio degli utensili utilizzare sempre la chiave di contrasto come indicato nel manuale d'uso.
- For disassembly of the tools use always the contrast key as mentioned in the user instructions.
- Fuer das Abmontieren der Werkzeuge immer den Gegenschlüssel benutzen wie in der Bedienungsanleitung erwaeht.

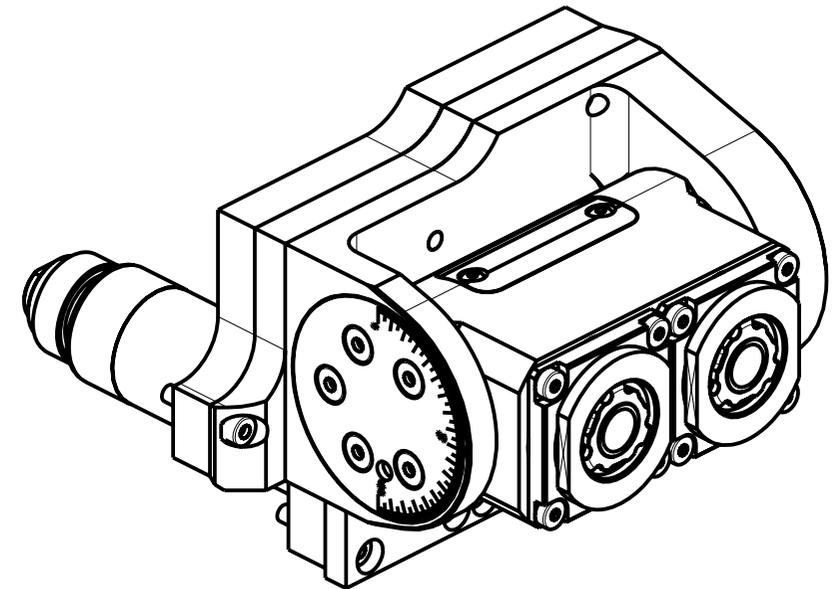
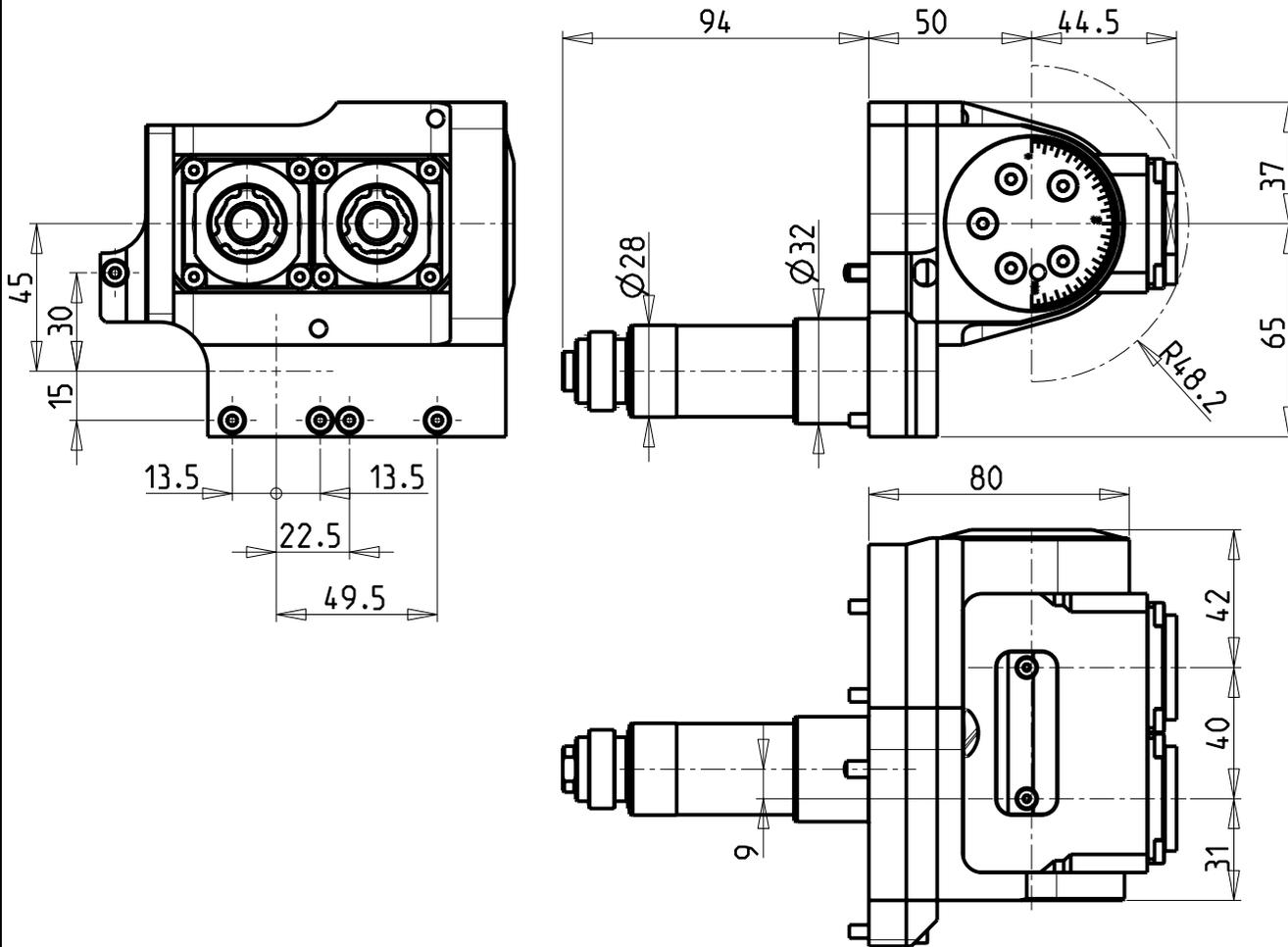

Cod. MT	Mandrino Spindle Spindel	I	RPM	Lubrificazione est. Ext. coolant Aussenkuehlung	CHIAVI INCLUSE Keys included Schluessel inbegriffen		
SPC0951000	ERA16	1:1	6000	X	CHUB32	CHUB19_SP3	CHTAER16ZC

NOMURA
MOD: NN20J - NN20J2 - NN20JS

MODULO MOTORIZZATO ORIENTABILE DOPPIO $\pm 90^\circ$
 $\pm 90^\circ$ double adjustable angle driven tool
 Doppel-Angetriebenes Werkzeug schwenkbar $\pm 90^\circ$

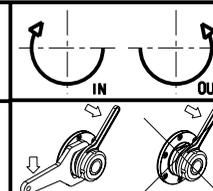

M.T. srl
 Via Casino Albini 480
 Tel. 0541/956034-957884
 Fax 0541/956341
 47842 S. GIOVANNI IN M. (RN)
 e-mail: mtma@mtmarchetti.com
 http://www.mtmarchetti.com

PRODUZIONE MODULI ROTANTI



PAGINA NOM338-1-00

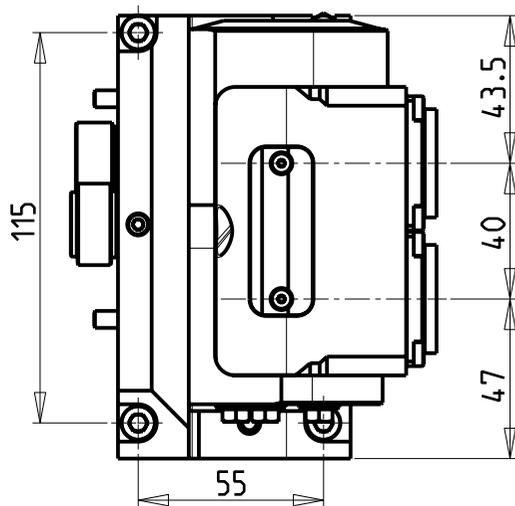
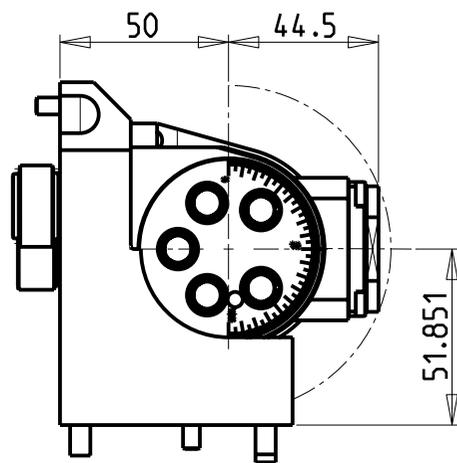
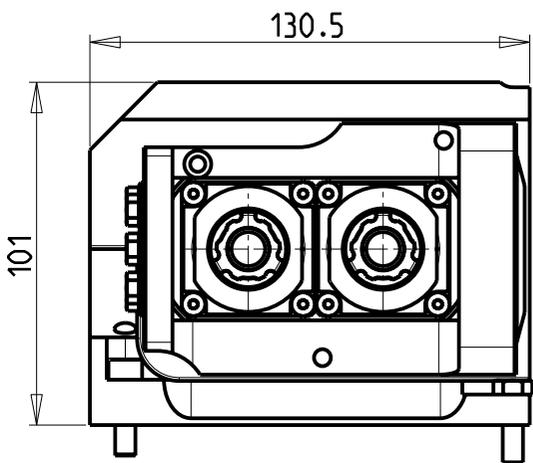

ATTENZIONE - ATTENTION - ACHTUNG

- Per lo smontaggio degli utensili utilizzare sempre la chiave di contrasto come indicato nel manuale d'uso.
- For disassembly of the tools use always the contrast key as mentioned in the user instructions.
- Fuer das Abmontieren der Werkzeuge immer den Gegenschlüssel benutzen wie in der Bedienungsanleitung erwaeht.

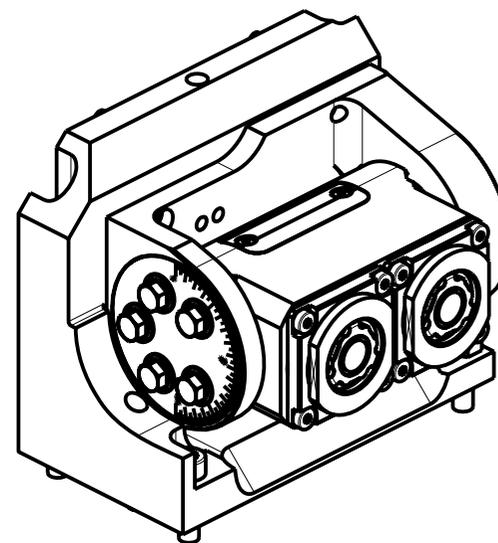

Cod. MT	Mandrino Spindle Spindel	I	RPM	Lubrificazione est. Ext. coolant Aussenkuehlung	CHIAVI INCLUSE Keys included Schluessel inbegriffen				
NMR0020216	ERA16	1:1	6000	X	CHUB32	CHUB19_SP3	CHTAER16ZC	CH_POLIG_08	NEW

NOMURA
MOD: NN20J - NN20J2 - NN20JS

MODULO MOTORIZZATO ORIENTABILE DOPPIO ±90° PER CONTROMANDRINO
±90° double adjustable angle driven tool for subspindle
Doppel-Angetriebenes Werkzeug schwenkbar ±90° fuer Gegenspindel

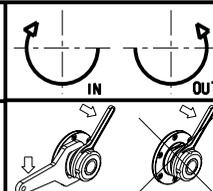

M.T. srl
Via Casino Albini 480
Tel. 0541/956034-957884
Fax 0541/956341
47842 S. GIOVANNI IN M. (RN)
e-mail: mtma@mtmarchetti.com
http://www.mtmarchetti.com

PRODUZIONE MODULI ROTANTI



PAGINA NOM338-1-10

ATTENZIONE - ATTENTION - ACHTUNG

- Per lo smontaggio degli utensili utilizzare sempre la chiave di contrasto come indicato nel manuale d'uso.
- For disassembly of the tools use always the contrast key as mentioned in the user instructions.
- Fuer das Abmontieren der Werkzeuge immer den Gegenschlüssel benutzen wie in der Bedienungsanleitung erwäehnt.

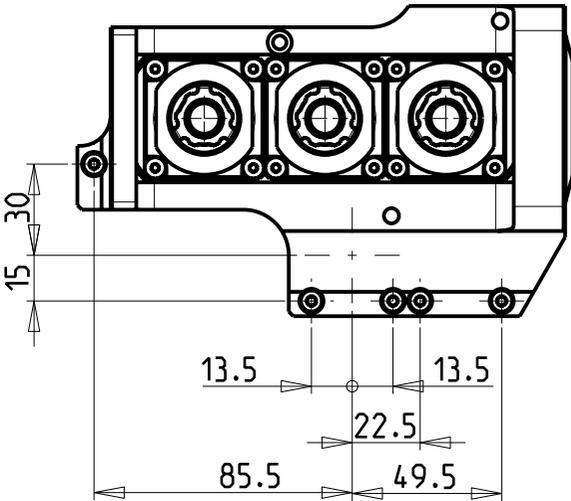
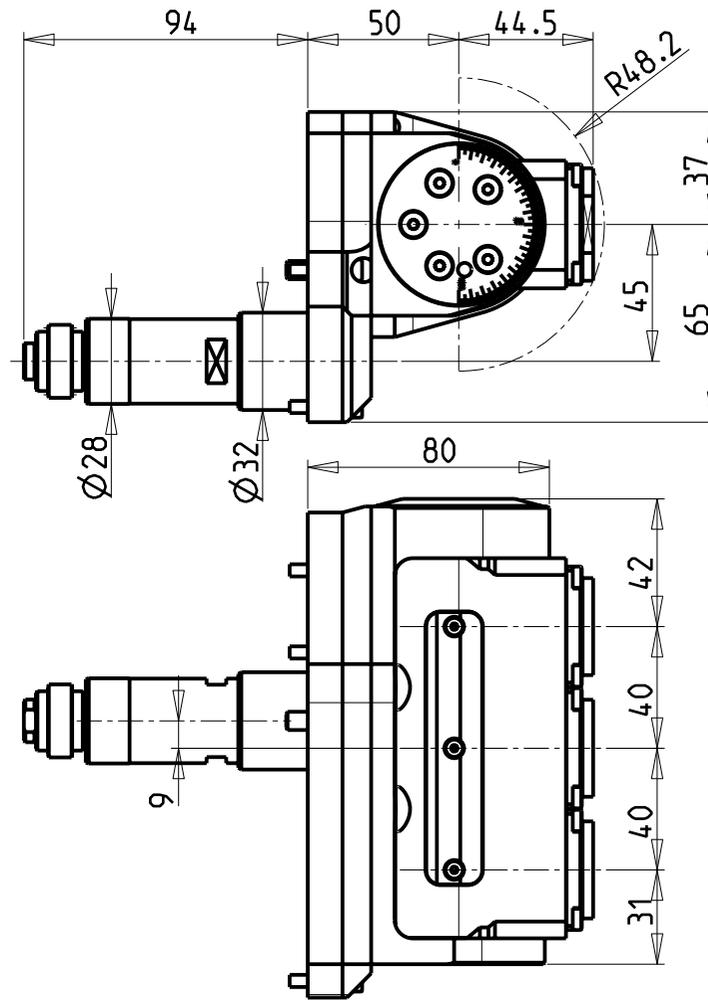
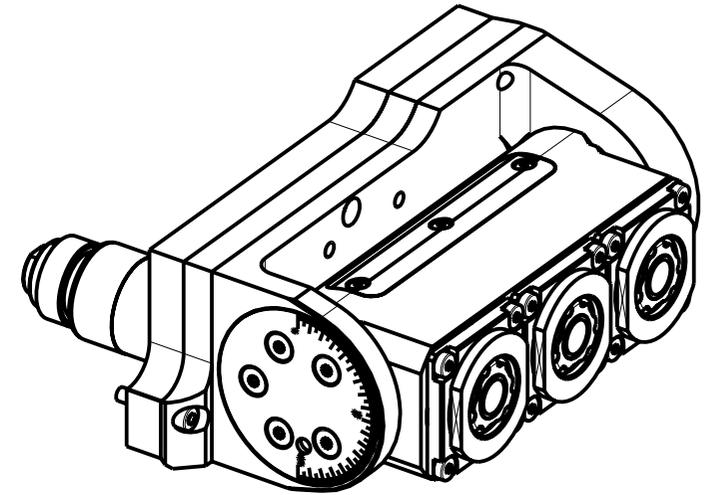

Cod. MT	Mandrino Spindle Spindel	I	RPM	Lubrificazione est. Ext. coolant Aussenkuehlung	CHIAVI INCLUSE Keys included Schluessel inbegriffen			
NMR0040316	ERA16	1:1	6000	X	NMR0040012	CHUB19_SP3	CHTAER16ZC	NEW

NOMURA
 MOD: NN20J - NN20J2 - NN20JS
 MODULO MOTORIZZATO ORIENTABILE TRIPLO ±90°
 ±90° triple adjustable angle driven tool
 Dreifach-Angetriebenes Werkzeug schwenkbar ±90°

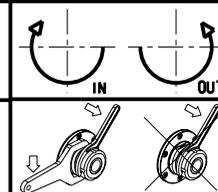

M.T. srl
 Via Casino Albini 480
 Tel. 0541/956034-957884
 Fax 0541/956341
 47842 S. GIOVANNI IN M. (RN)
 e-mail: mtma@mtmarchetti.com
 http://www.mtmarchetti.com

PRODUZIONE MODULI ROTANTI

PAGINA NOM338-1-20

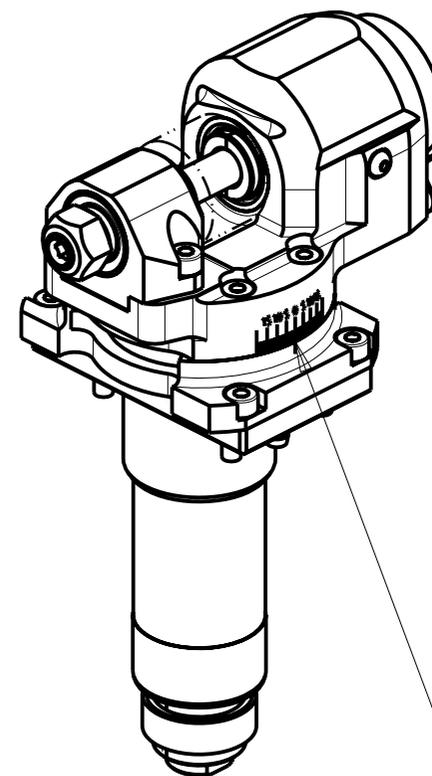
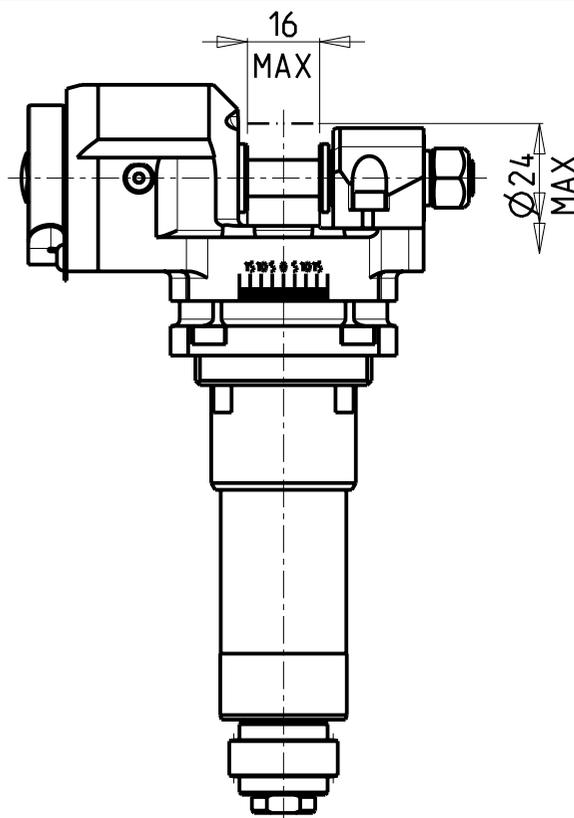
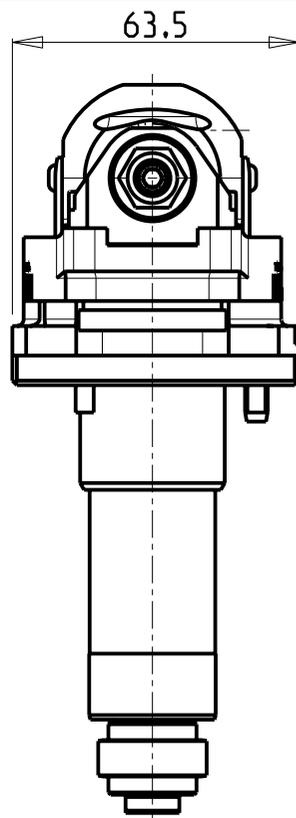
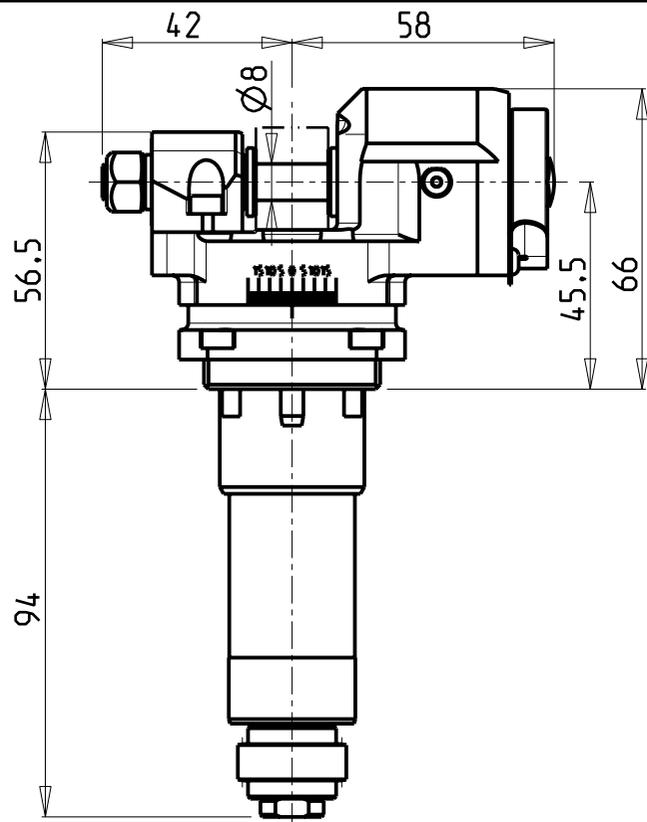

INCLINAZIONE
REGOLABILE $\pm 20^\circ$

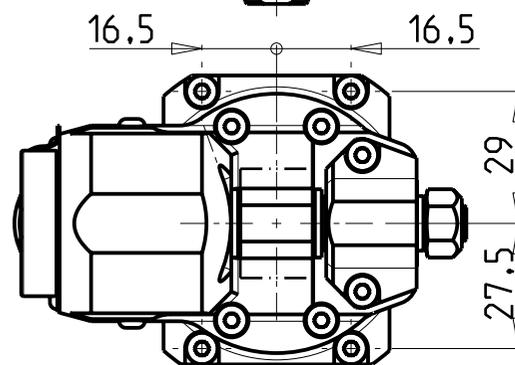

Cod. MT	I	RPM max	Lubrificazione est. Ext. coolant Aussenkuehlung	CHIAVI INCLUSE Keys included Schluessel inbegriffen		
SPC0971000	1:1	6000	X	CHESL04	CHUB13	NEW

NOMURA
MOD: NN20J - NN20J2 - NN20JS
MODULO MOTORIZZATO PORTACREATORE
Driven gear hobber
Angetriebenes Zahnradwaelzfraes-Werkzeug

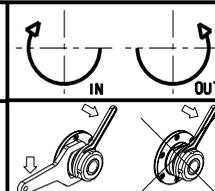

M.T. srl
Via Casino Albini 480
Tel. 0541/956034-957884
Fax 0541/956341
47842 S. GIOVANNI IN M. (RN)
e-mail: mtma@mtmarchetti.com
http://www.mtmarchetti.com

PRODUZIONE MODULI ROTANTI



PAGINA NOM340-1-00

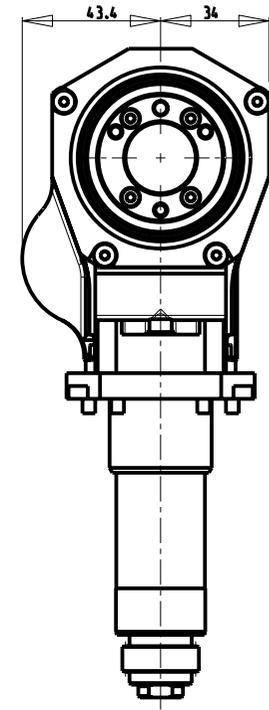
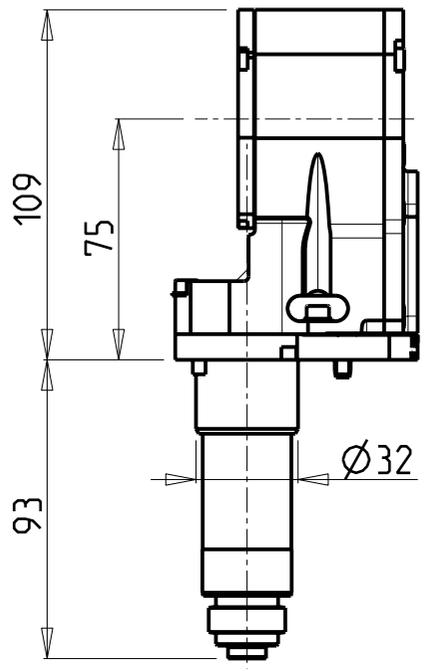
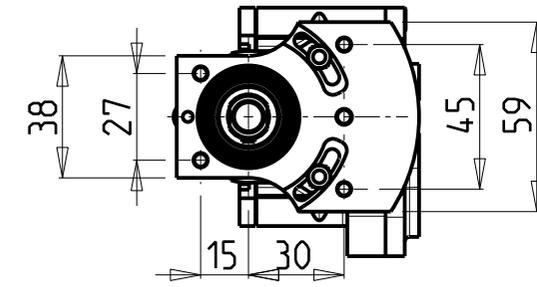

INCLINAZIONE
REGOLABILE ±15°

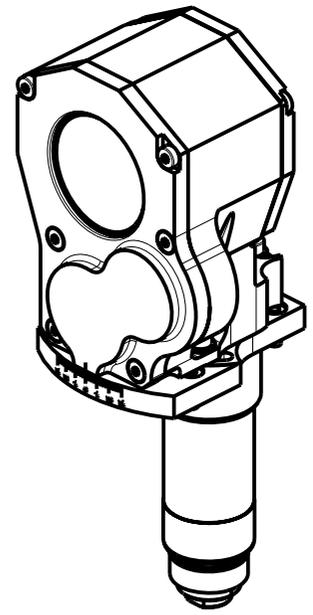
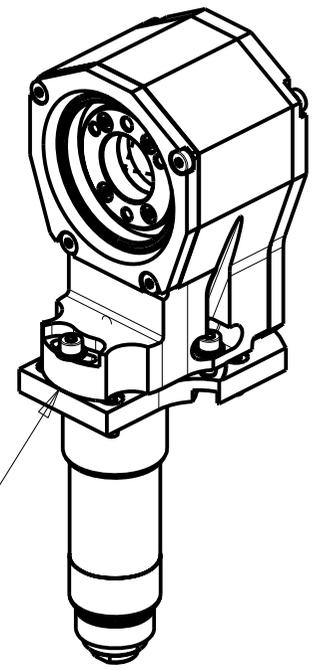

Cod. MT	I	RPM	Lubrificazione est. Ext. coolant Aussenkuehlung	
NMR0010112	2:1	3000	X	NEW

NOMURA
 MOD: NN20J - NN20J2 - NN20JS
 MODULO MOTORIZZATO TURBINATORE RIDOTTO I=2:1
 Driven whirling tool geared-down I=2:1
 Gewindewirbeleinrichtung untersetzt I=2:1

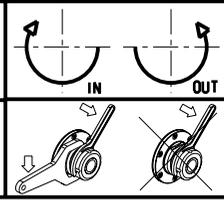

M.T. srl
 Via Casino Albini 480
 Tel. 0541/956034-957884
 Fax 0541/956341
 47842 S. GIOVANNI IN M. (RN)
 e-mail: mtma@mtmarchetti.com
 http://www.mtmarchetti.com

PRODUZIONE MODULI ROTANTI



PAGINA NOM370-1-00

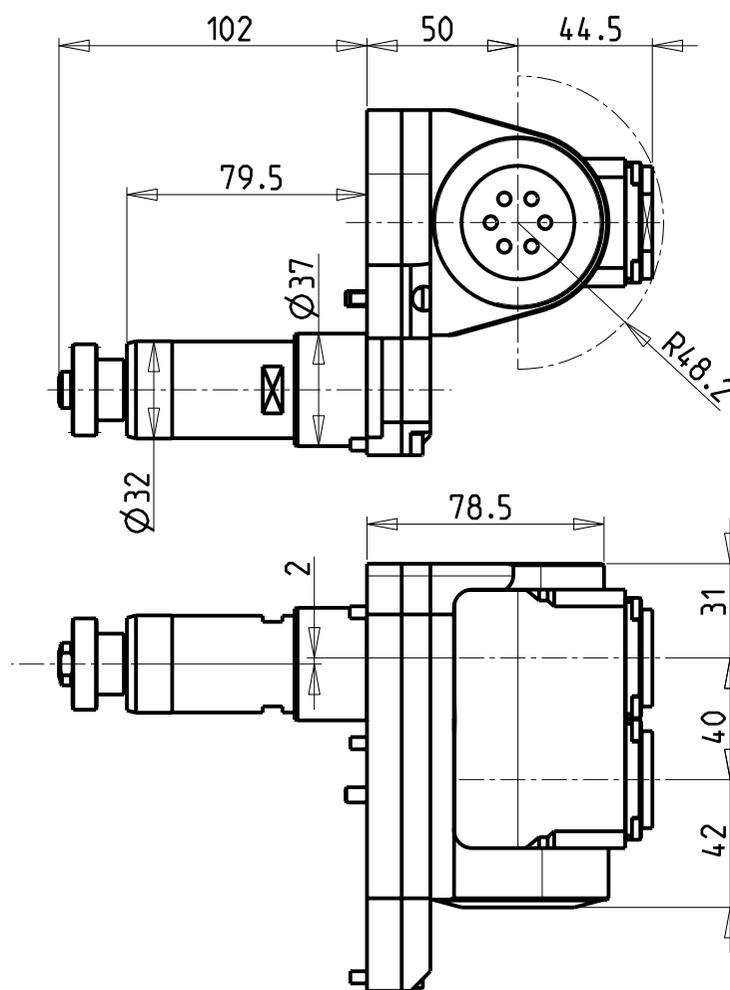
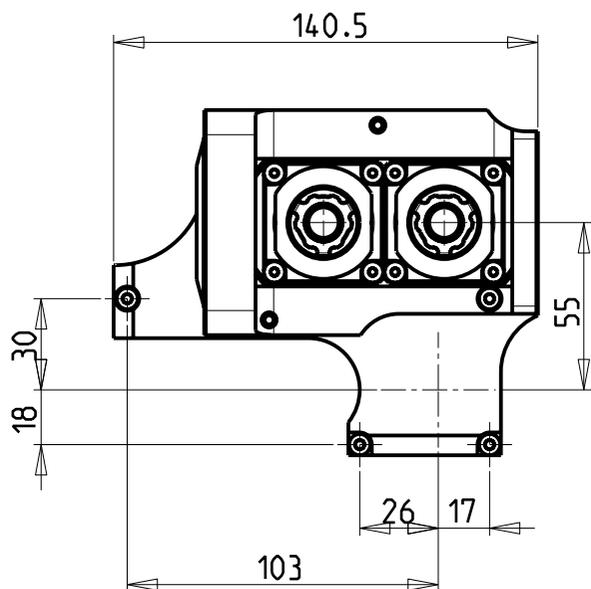

ATTENZIONE - ATTENTION - ACHTUNG

- Per lo smontaggio degli utensili utilizzare sempre la chiave di contrasto come indicato nel manuale d'uso.
- For disassembly of the tools use always the contrast key as mentioned in the user instructions.
- Fuer das Abmontieren der Werkzeuge immer den Gegenschlüssel benutzen wie in der Bedienungsanleitung erwäehnt.

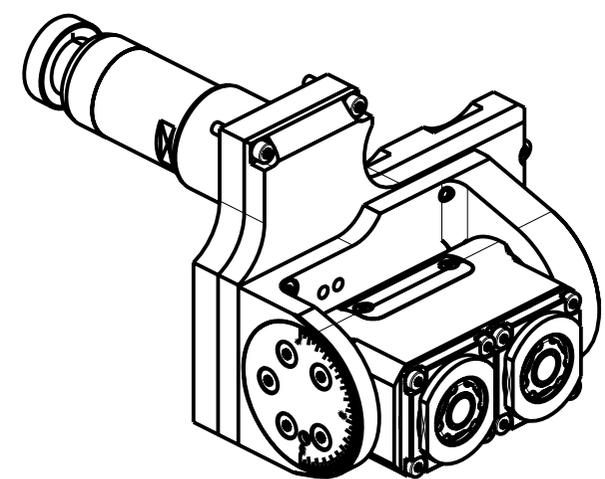

Cod. MT	Mandrino Spindle Spindel	I	RPM	Lubrificazione est. Ext. coolant Aussenkuehlung	CHIAVI INCLUSE Keys included Schluessel inbegriffen		
NMR0030216	ERA16	1:1	6000	X	CHUB32	CHUB19_SP3	CHTAER16ZC

NEW

NOMURA
MOD: NN32YB2

MODULO MOTORIZZATO ORIENTABILE DOPPIO ±90°
±90° double adjustable angle driven tool
Doppel-Angetriebenes Werkzeug schwenkbar ±90°

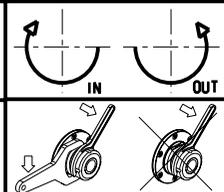

M.T. srl
Via Casino Albini 480
Tel. 0541/956034-957884
Fax 0541/956341
47842 S. GIOVANNI IN M. (RN)
e-mail: mtma@mtmarchetti.com
http://www.mtmarchetti.com

PRODUZIONE MODULI ROTANTI

PAGINA NOM338-2-00